



INSTALLATION & USER'S GUIDE

RadiusCX Clutch
For KTM/Husqvarna DDS clutches

Doc ID: 191-7901A
Revision: 102323

TABLE OF CONTENTS

OVERVIEW	3
INSTALLATION TIPS	3
TOOLS NEEDED	4
INCLUDED PARTS	5
DISASSEMBLE THE CLUTCH	6
INSPECT THE DAMPERS	8
INSTALL HUBS	9
CLUTCH PACK INSTALLATION.....	11
PRESSURE PLATE INSTALLATION.....	16
SLAVE CYLINDER INSTALLATION	21
Step 1: Bleed the new slave cylinder.....	21
Step 2: Replace OE slave cylinder	24
BLEED THE CLUTCH LINE	28
SET THE INSTALLED GAP AND VERIFY BY CHECKING FREE PLAY GAIN	31
Step 1: Find the starting point.....	32
Step 2: Learn how to check Free Play Gain	33
Two Ways to Check for Free Play Gain	35
The Rubber Band Method	35
The Hand Method.....	38
Step 3: Break-in the new clutch.....	39
Step 4: Adjust the installed gap and Recheck Free Play Gain ...	41
FREE PLAY GAIN ADJUSTMENTS	43
MAINTENANCE	44
TROUBLESHOOTING	47
Performance issues.....	47
Clutch noise.....	47
EXP TUNING OPTIONS	47
Changing the springs	48
BUMP-STARTING.....	50
NEED ADDITIONAL HELP?	50

OVERVIEW

This kit replaces many of the OE (Original Equipment) clutch parts while reusing some of the OE clutch parts. The following is a summary of what is replaced and what is reused:

- The OE center clutch hub and OE pressure plate. The OE clutch is replaced with high-quality billet components. These parts are designed specifically for your motorcycle to ensure optimal performance.
- All OE steel drive plates will be replaced with Rekluse TEC drive plates
- All OE friction disks will be replaced with Rekluse TorqDrive® disks
- All 6 of the OE drive pins will be reinstalled
- The OE clutch cover O-ring will be reused

INSTALLATION TIPS

- Read the safety information sheet included with your kit.
- Watch the “RadiusCX Auto Clutch Installation Video” by visiting www.rekluse.com/support/videos.
- Protect eyes and skin – wear safety glasses and thin disposable work gloves.
- Read this entire document before performing any steps.
- Lay the motorcycle on its left side when replacing the clutch. This makes the clutch work easier and eliminates the need to drain the oil.



- Use an air or electric impact wrench to remove the center clutch nut. If one is not available, you can place the bike in top gear and hold the rear brake while loosening the center clutch nut with a socket and breaker bar.
- Channel-lock pliers work best to bend the tabs of the washer up over the center clutch nut.
- For optimal clutch performance Rekluse recommends using fresh, clean oil that **meets JASO-MA** oil rating requirements. Rekluse offers Factory Formulated Oil™ developed specifically for Rekluse products. Rekluse Factory Formulated Oil is a perfect complement to any OEM or aftermarket wet clutch. Visit www.rekluse.com to learn more.
- Motorcycles with taller gearing or modified engines with increased horsepower may require heavier wedges. These can be purchased separately from Rekluse.

Tuning Note: (especially for 2-stroke owners):

- Once installed, if you desire your clutch to engage more aggressively, one option is to purchase the heavier Belleville spring from KTM (KTM calls it the “280” spring).
- Replacing this spring makes the clutch engagement more aggressive. However, this will increase the pull on the clutch lever. The spring comes stock on 2013 and newer Factory Edition 450SX-F bikes, 2014 and newer 450SX-F/XC-F bikes, 2017 and newer 450/500 EXC-F bikes.
- The part number is KTM Part #: 78932005000

TOOLS NEEDED

- 4 mm Allen Wrench
- 5 mm Allen Wrench
- 8 mm Socket
- 27 mm Socket
- Channel-lock Pliers
- T-25 Torx Bit
- Torque Wrench
- Fluid Catch Container
- Oil
- Recommended Clutch Fluid

INCLUDED PARTS

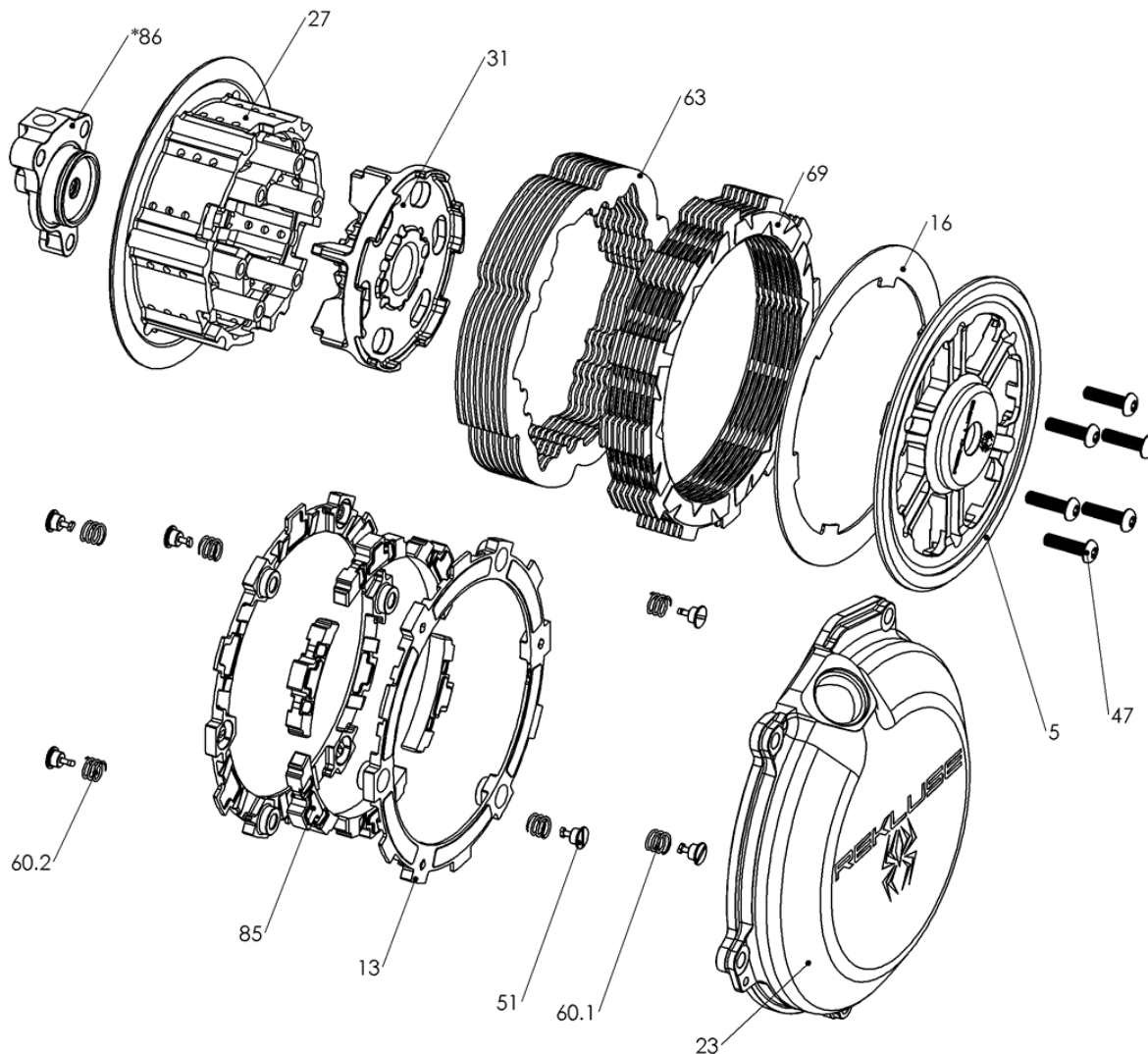

Item	Description	Qty.
5	Pressure Plate	1
13	EXP Bases	2
16	Steel Lining Plate	1
23	Clutch Cover	1
27	Outer Hub	1
31	Inner Hub (Included for 450SX-F and 450XC-F model clutches)	1
47	Fastener - M5 x 20 T-25 <u>Torx</u> Screw (T-25 <u>Torx</u> bit included)	6
51	Fastener - 1/4-Turn Pin	6
60.X	EXP Adjustment Spring (Extra adjustment springs are included. See EXP tuning options section for more information.)	6
63	TEC Steel Drive Plate	9
69	TorqDrive® Friction	8
85	Wedge Assembly	6
86	Adjustable Slave Cylinder Assembly	1

Visit www.rekluse.com/support for a full parts fiche illustration and part numbers.

DISASSEMBLE THE CLUTCH

1. Turn the fuel petcock to “OFF” if applicable.

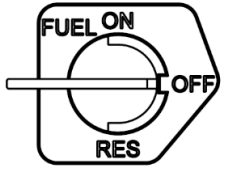

2. Lay the bike on its left side. Catch any fuel that might drain in a suitable container.



3. Use an 8 mm socket to remove the clutch cover. If your bike has an oil plug, loosen the plug before removing the cover.



4. Use an 8 mm socket to remove the following OE parts. When removing the Belleville spring, make sure to note the orientation of the spring. See following picture for reference.

- 6 pressure plate screws
- Pressure ring
- Belleville spring
- Slider ring
- Pressure plate
- Throw-out bearing and washer
- Clutch pack
- 6 drive pins
- Center clutch nut and washer
(Removed in step 5)

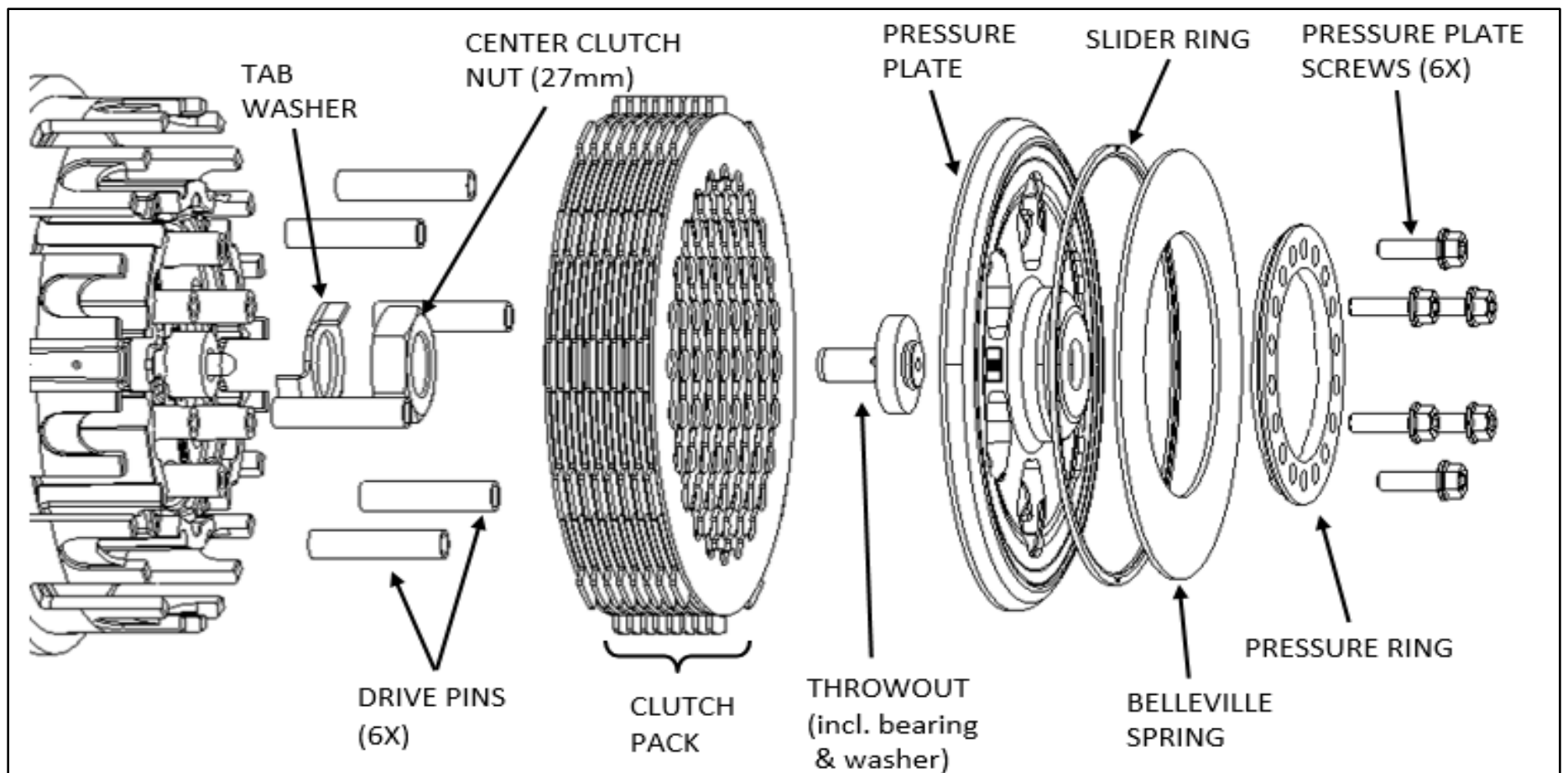

⚠ CAUTION

Be careful that the drive pins do not fall into the engine while disassembling.

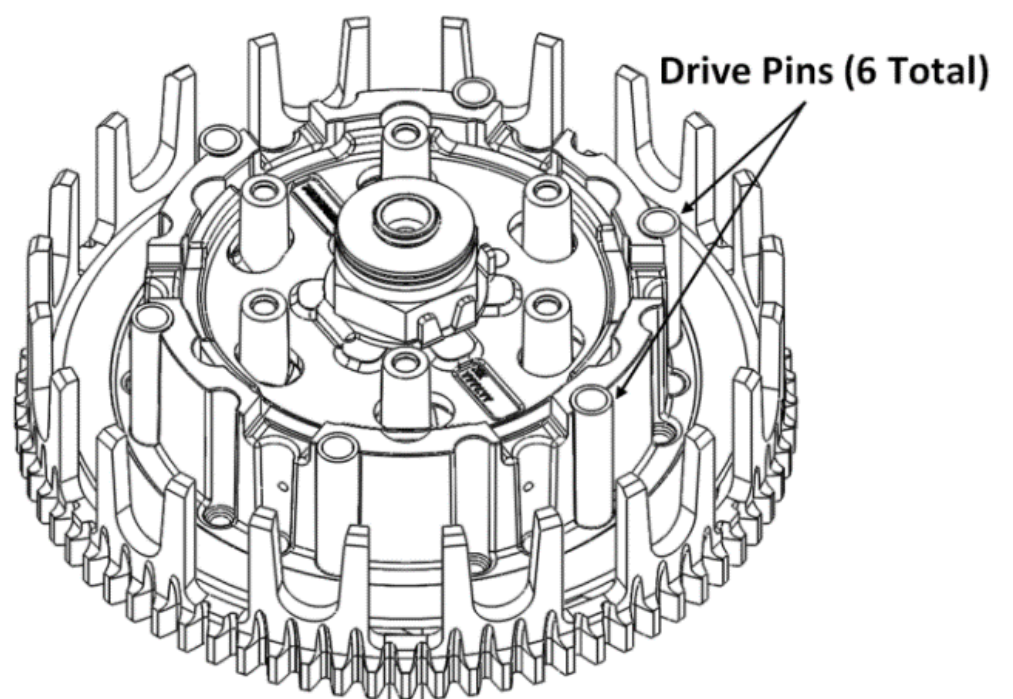

5. If the bike uses a lock tab washer, use a hammer and large screwdriver to bend down the tabs of the washer tab.

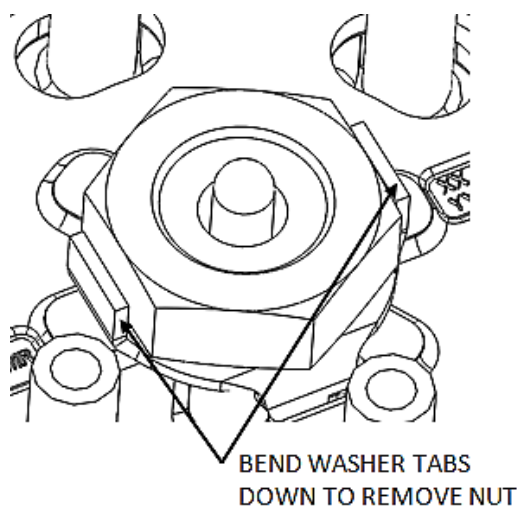

6. Remove the center clutch nut with an impact wrench or breaker bar, and a 27 mm socket.

7. Remove the OE center hub washer.

8. Remove the center hub assembly from the steel basket while leaving the thrust washer on the main shaft.

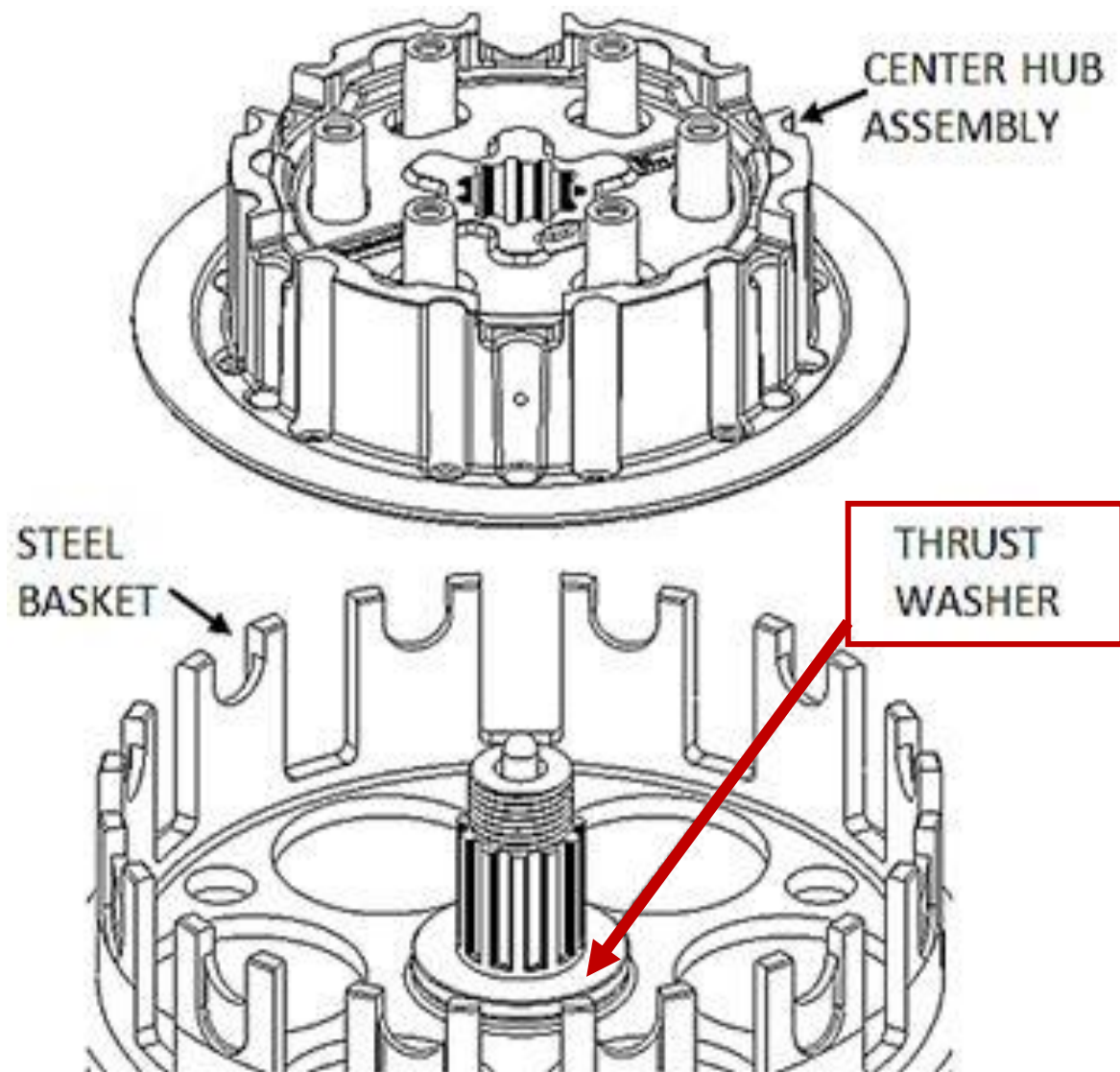

NOTICE

Check that the thrust washer is still on the main shaft and not stuck to the bottom of the center hub assembly. Missing the thrust washer will cause clutch performance issues.

INSPECT THE DAMPERS

The OE dampers inside the center hub assembly shrink due to heat and use. Any movement between the dampers will shorten the life of your clutch. Inspect the dampers before proceeding and replace if necessary. Use the following instructions to inspect the dampers.

1. Hold the center hub assembly in your hands, then place your thumbs on the inner hub by the embossed part numbers.

2. Rotate the inner hub back and forth inside the outer hub.



NOTICE

*Rekluse recommends replacing the dampers if you feel any play between the two hubs-**Rekluse Damper Kit Part #: RMS-0213080.***

INSTALL HUBS

1. Remove the 6 rubber dampers from the OE center hub assembly.

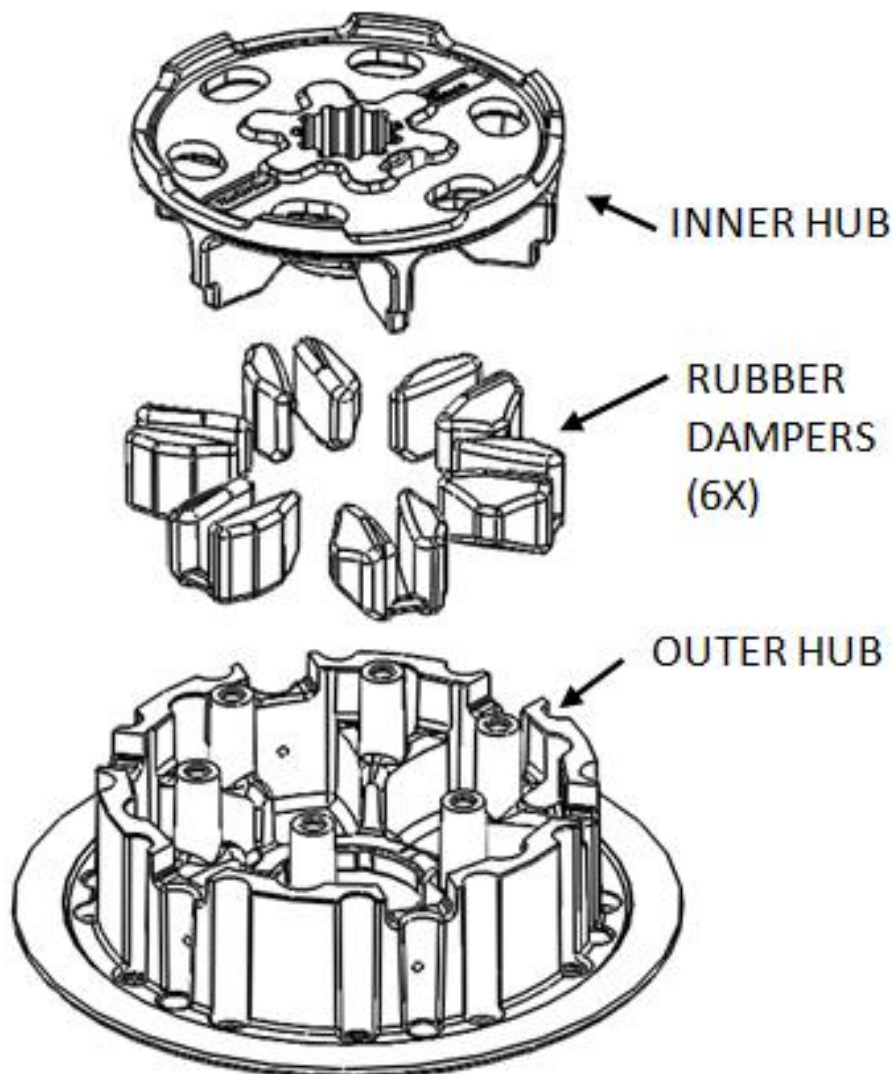

NOTICE

For 450SX-F/XC-F models, replace the OE inner hub with the supplied inner hub.

2. Install the 6 OE rubber dampers and inner hub onto the Rekluse outer hub.

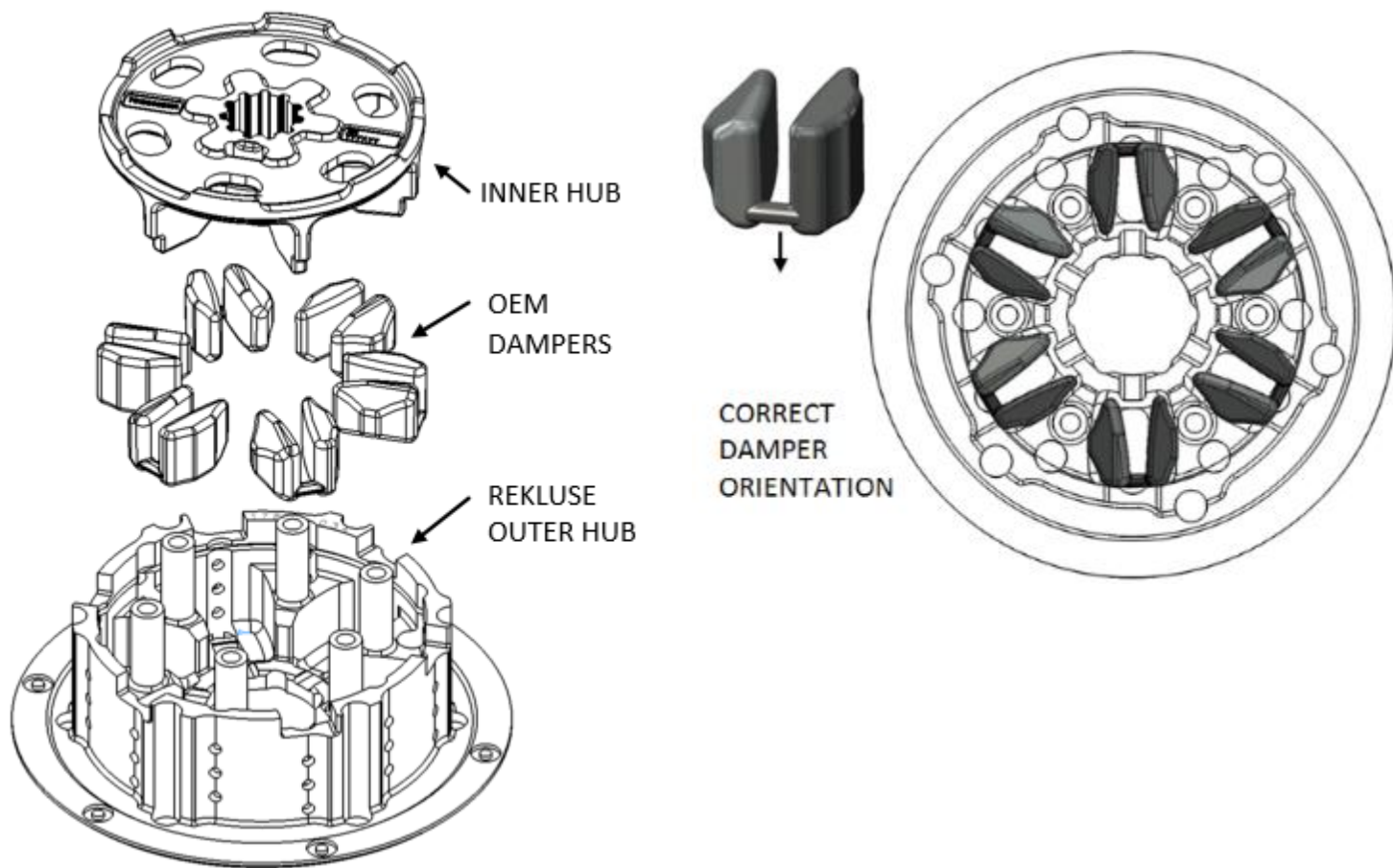

3. Install the new center hub assembly into the motorcycle.

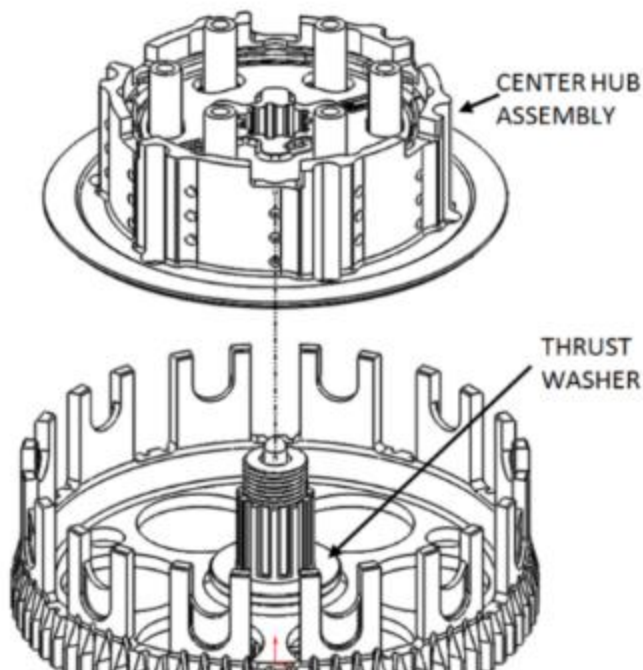

4. If your kit includes a lock tab washer, use this. If it does not, reuse the OE washer.

5. Using the 27 mm socket and torque wrench, torque the center clutch nut to **50** ft-lb (**68** N-m).

6. Using the channel-lock pliers, bend up **both** tabs of the tab washer around the nut.

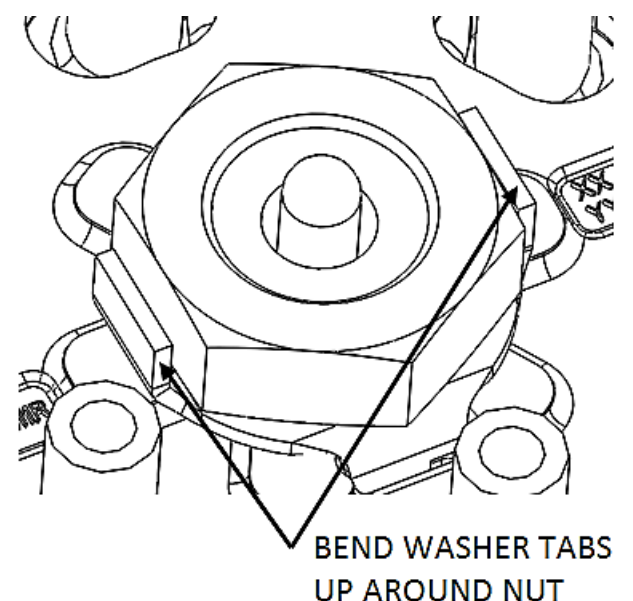

7. Seat the 6 OE drive pins into the Rekluse outer hub.

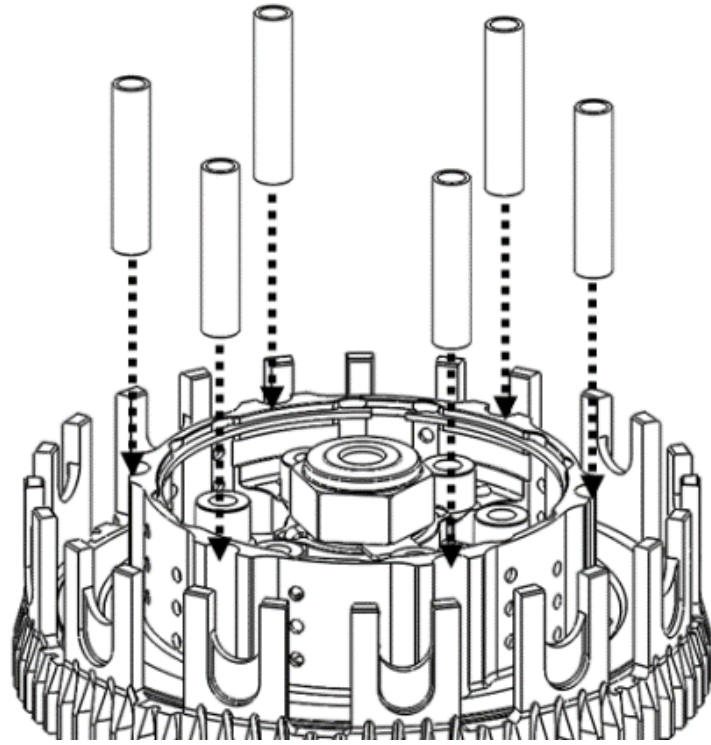

CLUTCH PACK INSTALLATION

Each clutch pack comes with a set of steel plates, a set of friction disks, and an EXP disk.

NOTICE

*The clutch pull effort has different pressure ring settings that depend on the thickness of the clutch pack. You will need to measure the clutch pack **BEFORE** you begin if you wish to optimize the clutch pull effort vs. clutch performance. Please refer to the Setup Sheet at the back of the manual for clutch pack specifications and information. Otherwise, continue with following instructions.*

1. Soak the friction disks and EXP disk in new oil for at least 5 minutes. Make sure the EXP and friction disks are coated on both sides.

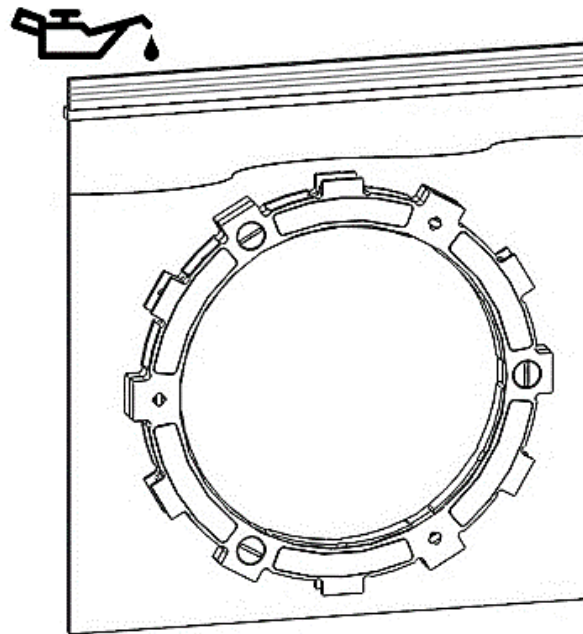

2. Install a steel TEC drive plate by first aligning the drive pin notches in the plate with the drive pins on the hub.

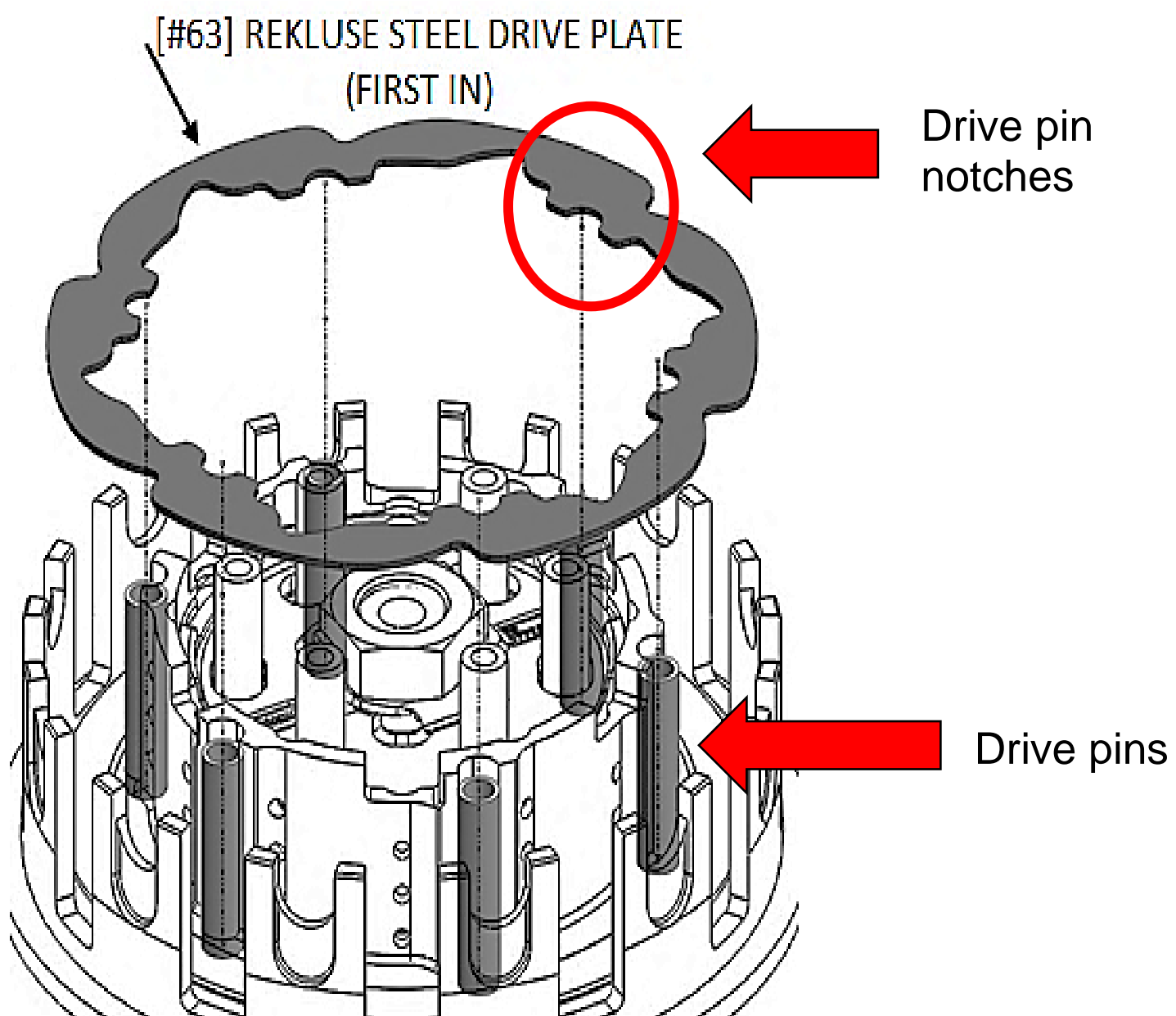

3. Place the steel plates in the orientation shown with the shark fin notches facing to the right. All drive plates will follow this orientation.

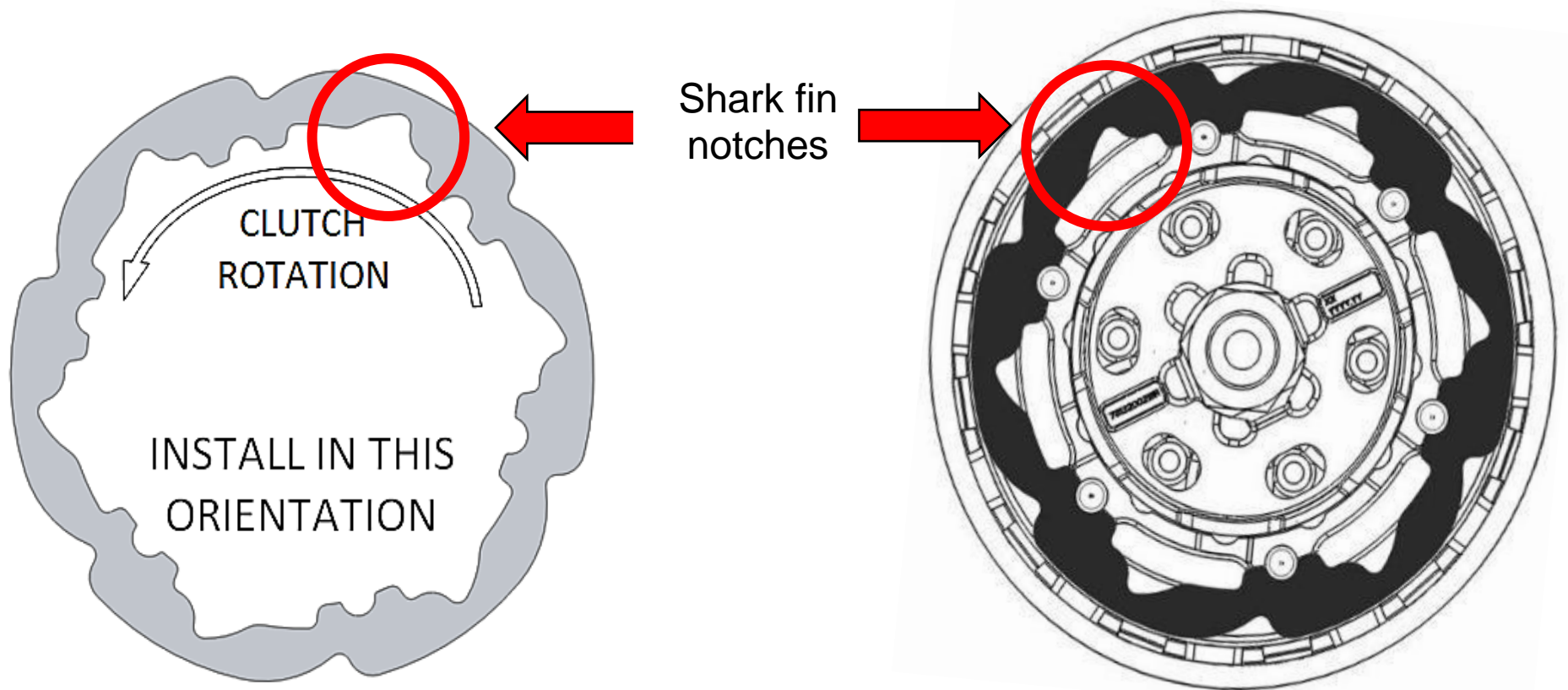

NOTICE

Proper orientation of the drive plates is critical for optimal clutch performance. If you install them backwards, the clutch will still function but will lack proper modulation performance.

4. Add a friction disk on top of the steel drive plate. Some friction disks are marked with a small colored dot. This mark is used for processing and can be ignored.
5. Continue alternating the steel drive plates with the friction disks for the entire Rekluse clutch pack. See the following picture for reference.

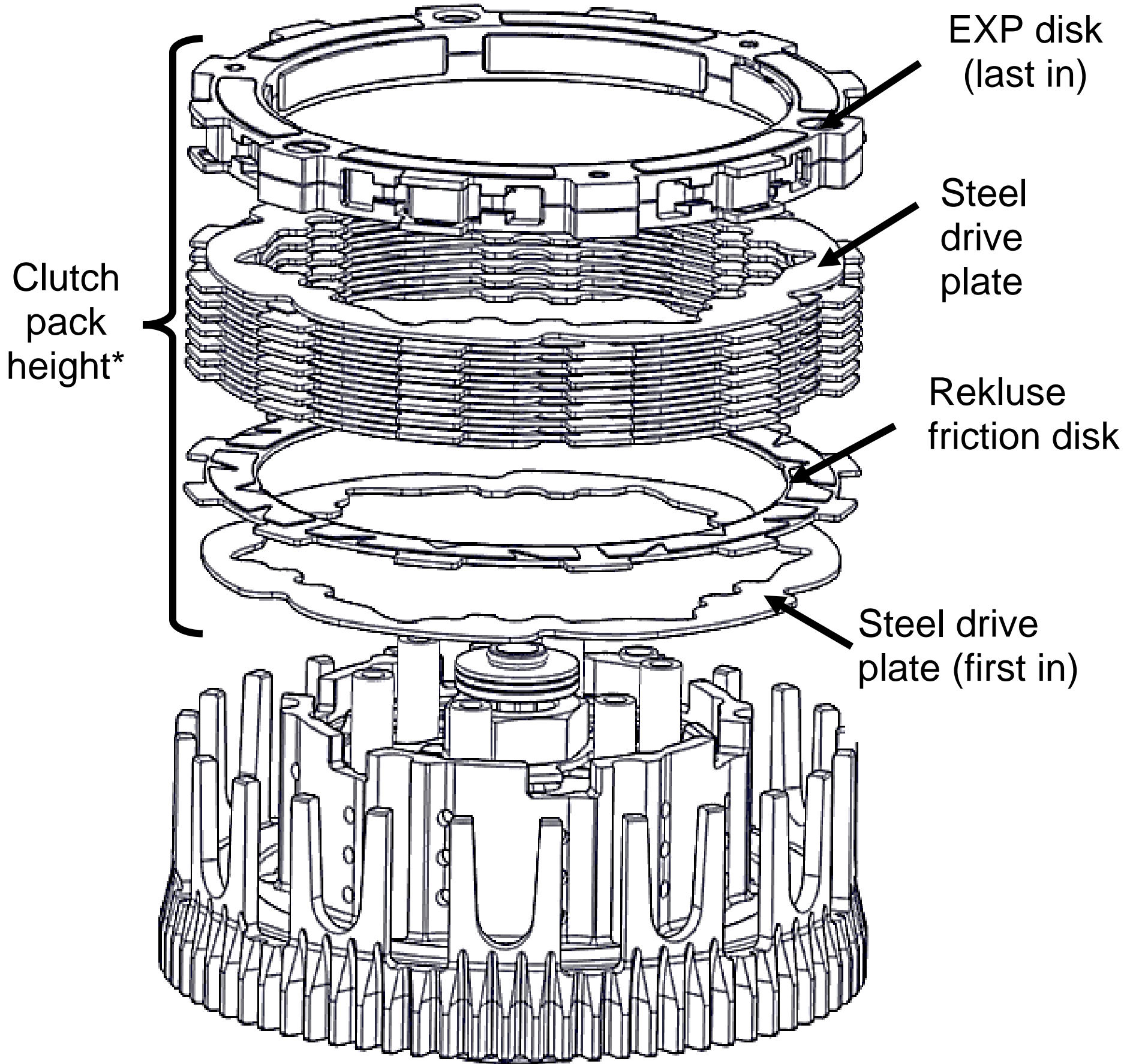

*Refer to the Setup Sheet at the back of the manual for the “Clutch Pack Height” specifications.

6. Install the EXP disk on top of the last steel plate. Make sure that the EXP disk is seated in the same slots as the clutch pack.

NOTICE

Some OE basket have “half slots” at the top of the basket tangs. Rekluse products require the entire clutch pack, including the EXP disk, be installed into the MAIN (deeper) basket slots.

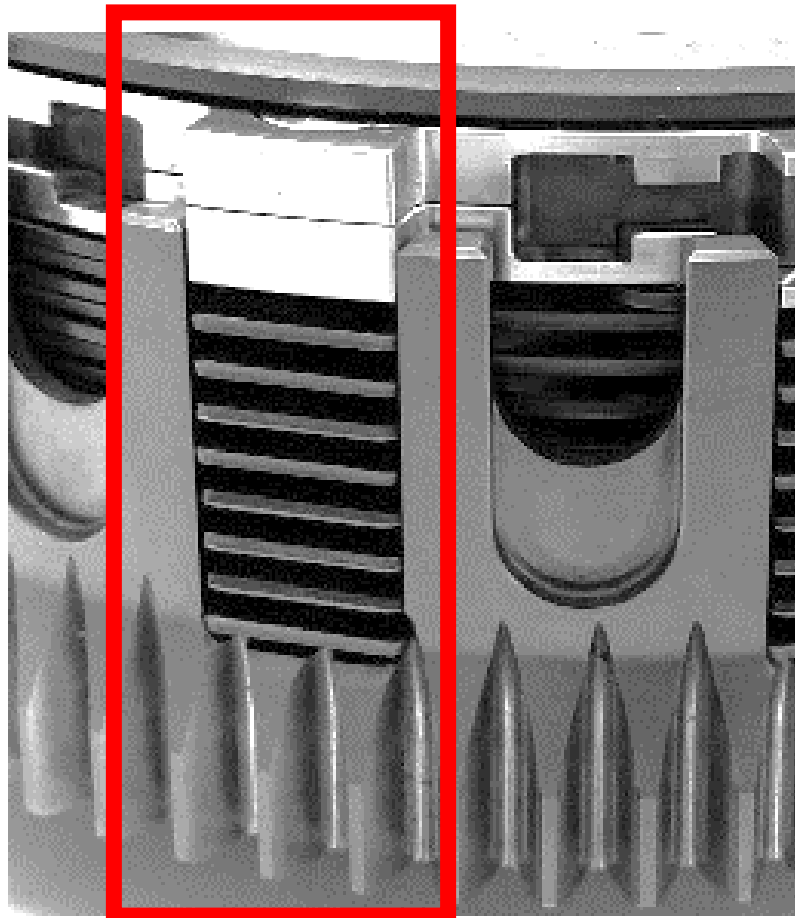

7. Reinstall the OE throw-out.

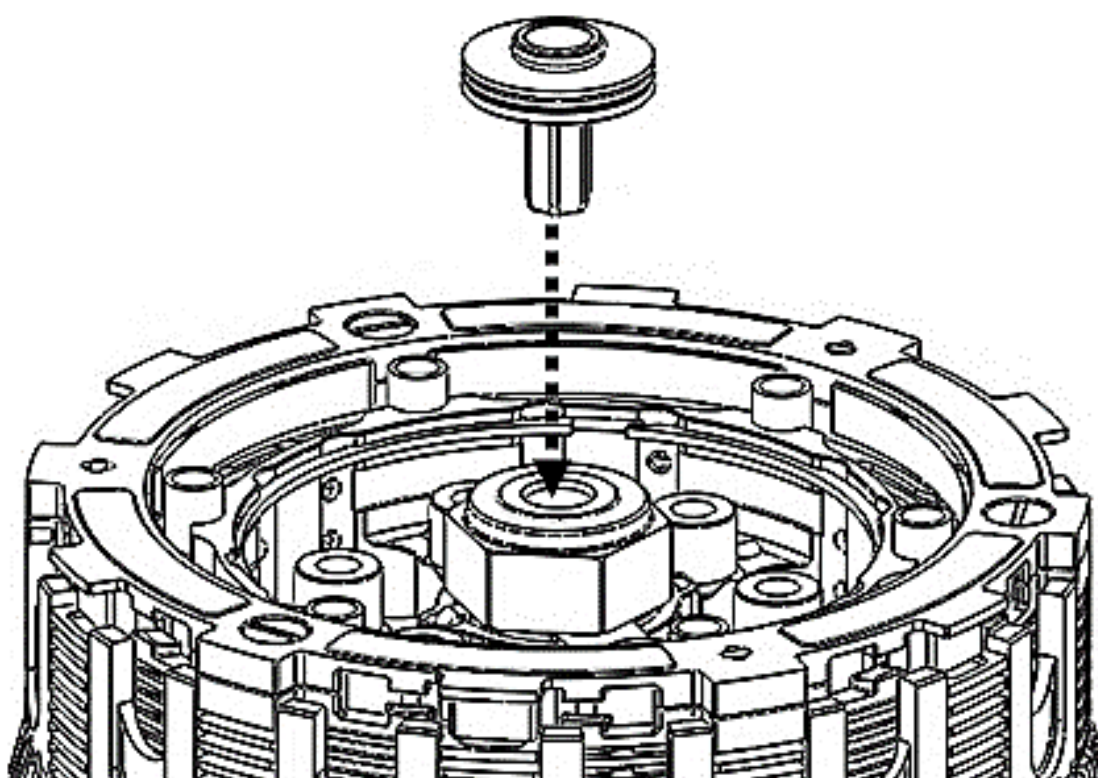

PRESSURE PLATE INSTALLATION

1. Add a light film of oil between the lining plate and pressure plate. This will help the plates stick together for ease of installation.
2. Install the supplied lining plate onto the pressure plate by lining up the index tabs into the slots.

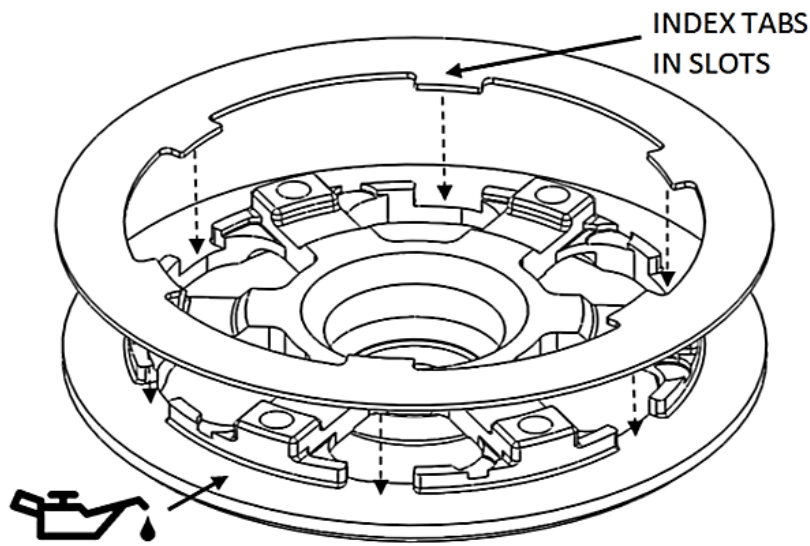

3. Install the pressure plate subassembly by lining up the index tabs on the pressure plate with the slots in the hub.

NOTICE

When the pressure plate is seated correctly, the threaded standoffs will come through the openings of the pressure plate.

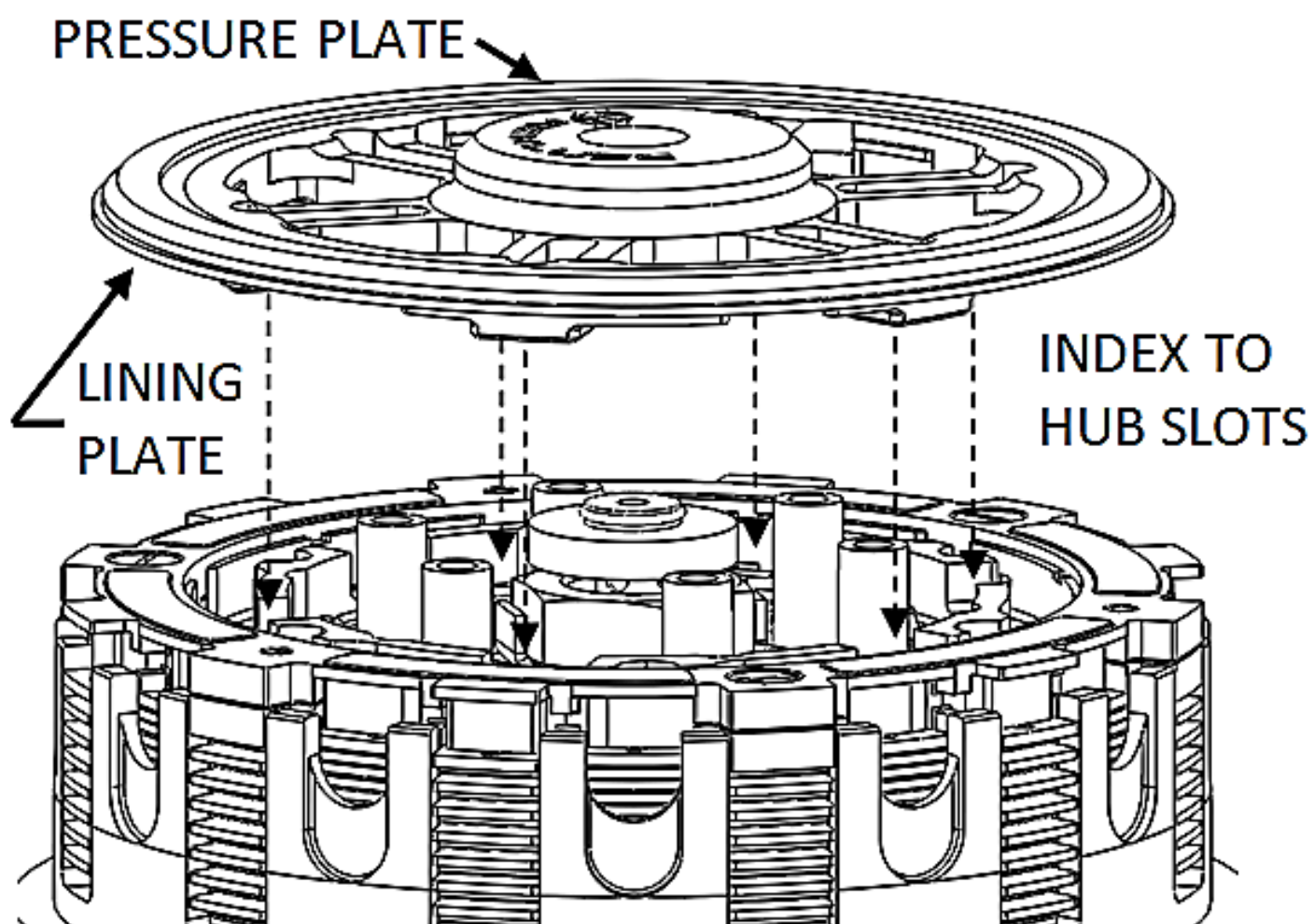

4. Place the OE slider ring on the pressure plate with the “top” marking facing up. (The top side is rounded and the bottom edge is sharp.)

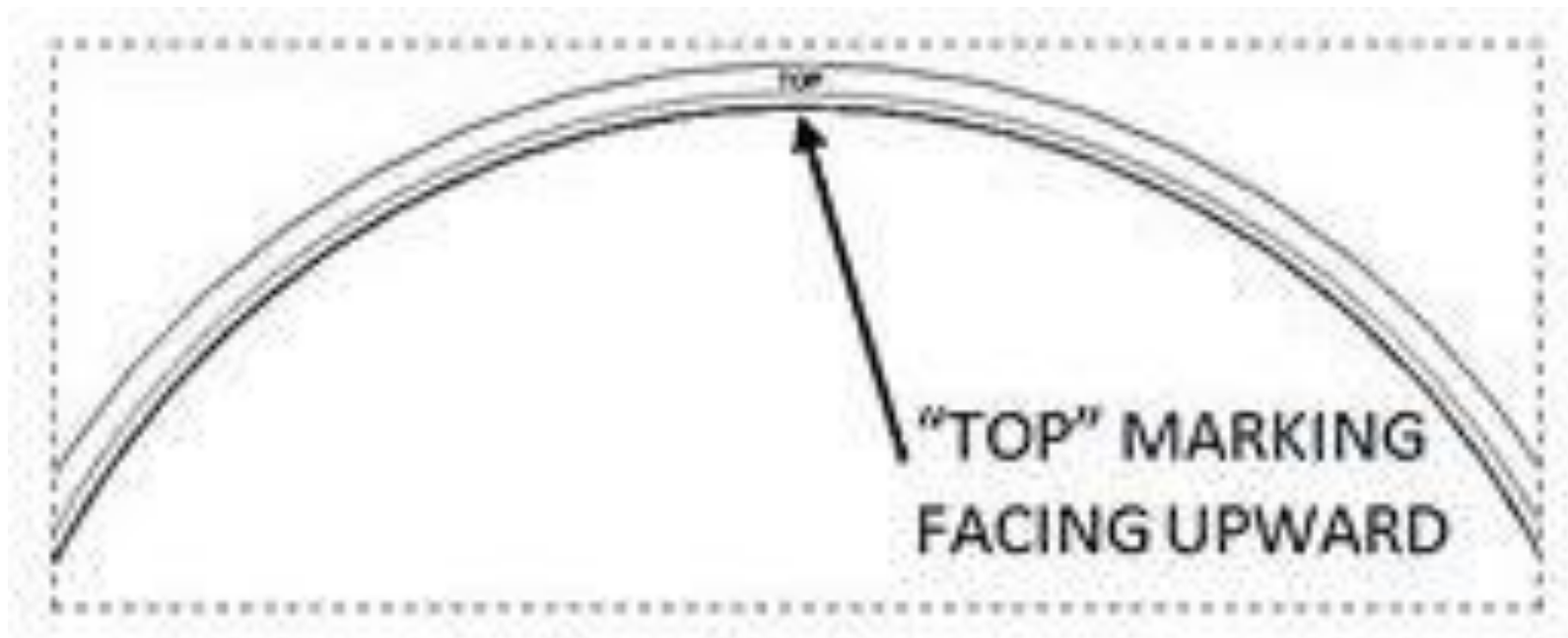

5. Place the OE Belleville spring onto the slider ring, with the rounded dome side facing up.

NOTICE

The outer edge of the Belleville spring will make contact with the slider ring. If it does not, the Belleville spring is upside down.

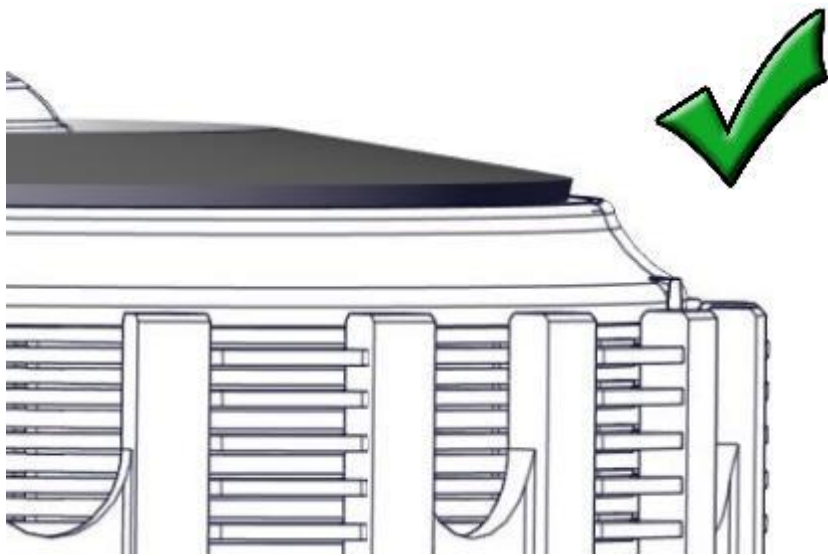

Correct – The Belleville spring sits flat against the slider ring.

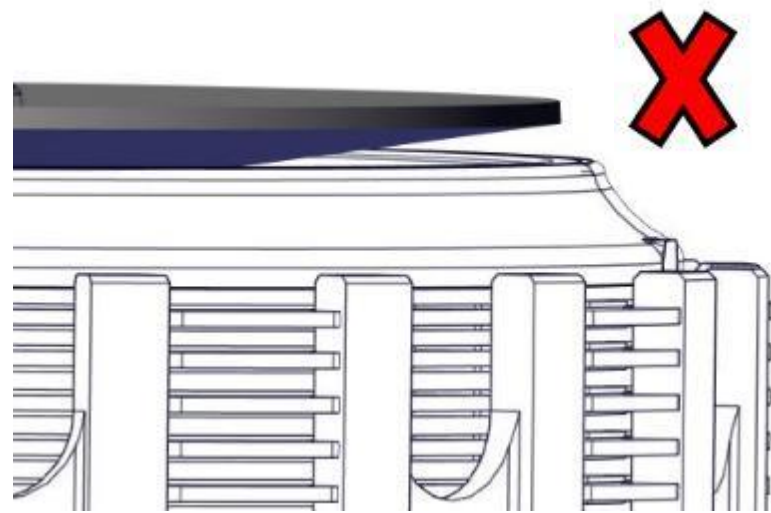

Incorrect – The Belleville spring is upside down.

6. Install the OE pressure ring, flat side up.

NOTICE

The spring ring optimized setting are found on the Setup Sheet located at the back of the manual. For a simple setting, set it to setting II (4-strokes and 2017 + 2-strokes) or X (pre 2017 2-strokes). In most cases, this is the best starting point for the clutch.

7. Install the Rekluse pressure plate screws.

CAUTION

Do not reuse the OE screws, or clutch cover interference will occur!

8. Loosely tighten the screws, then use the T-25 Torx bit and torque wrench to tighten to 55 in-lb (6 N-m).

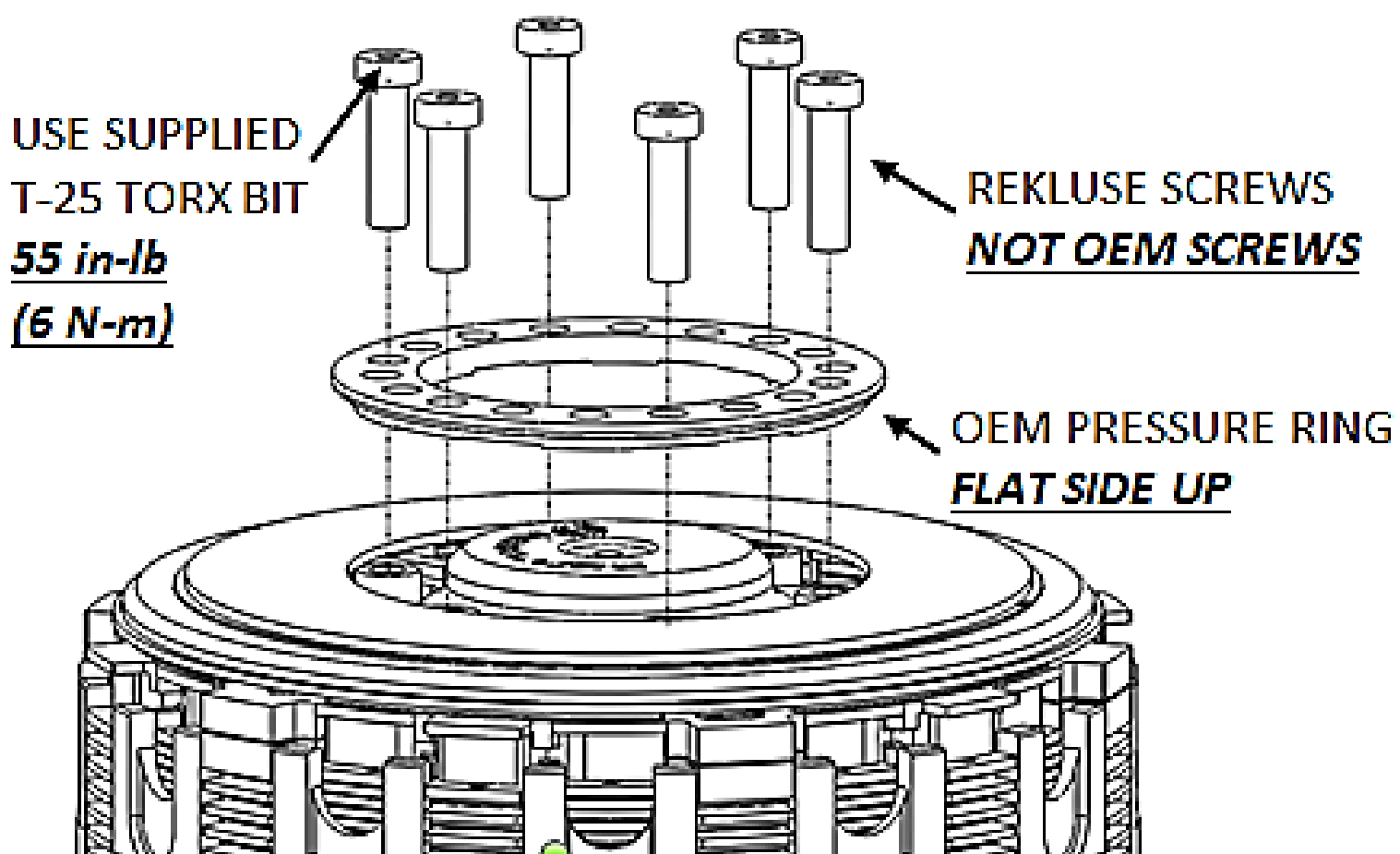

9. Remove the OE cover gasket from the OE clutch cover and install it onto the new Rekluse clutch cover.

10. Install the Rekluse clutch cover by lightly tightening the cover bolts in a star pattern. Tighten bolts in small increments before torqueing the cover bolts to OE specifications. If your bike has an oil plug, transfer the OE oil plug to the new Rekluse clutch cover.

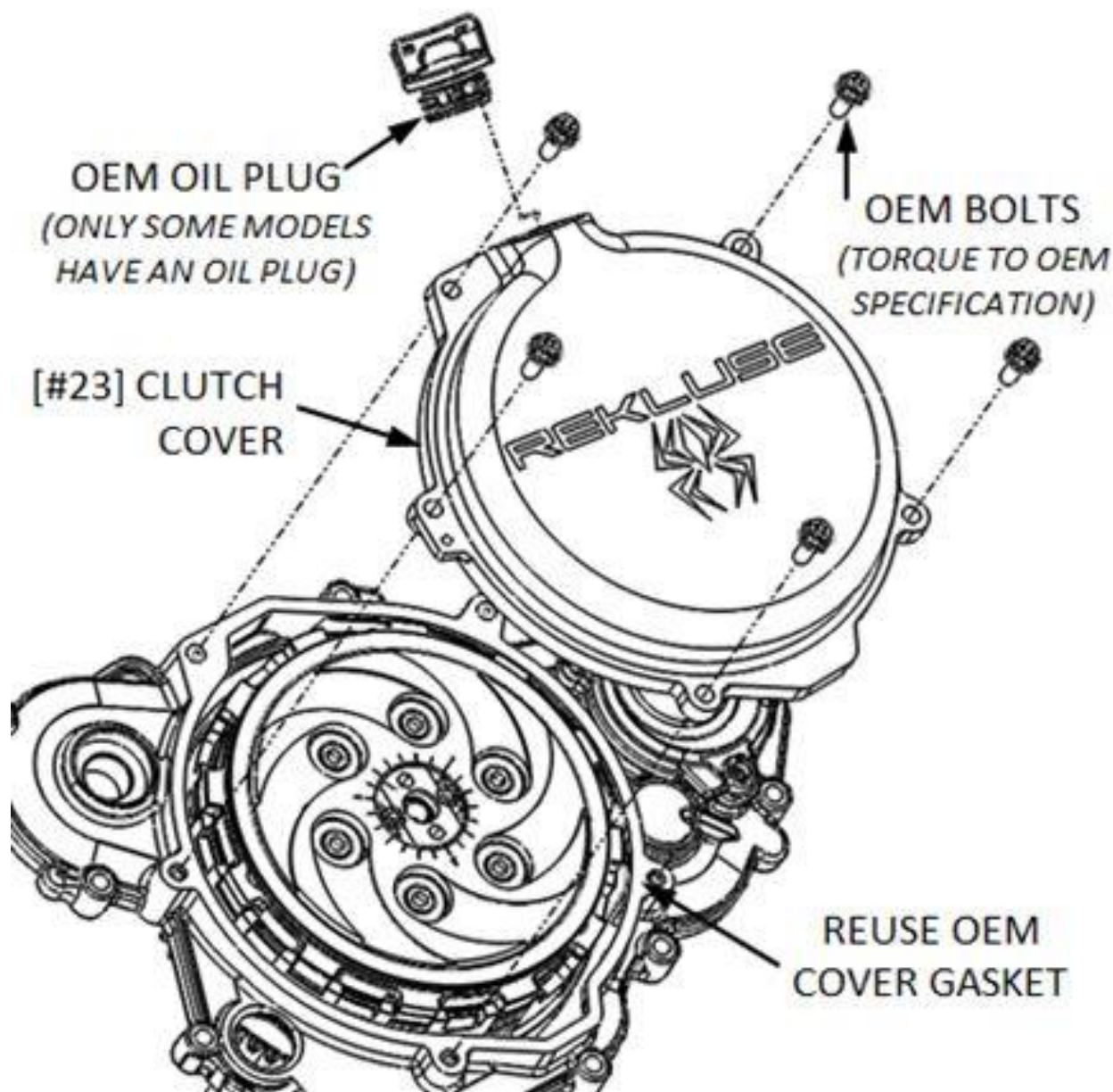



250/300 2-stroke 2017+ Enduro and 2017-2022 MX models:

- **Use 6 OE bolts and 1 Rekluse bolt.** Your Rekluse clutch cover kit comes with 1 longer bolt to replace a shorter OE bolt. Install 6 of the OE bolts in their original location and install the longer Rekluse bolt in the lower right hand corner. See following pictures for reference.

⚠ CAUTION

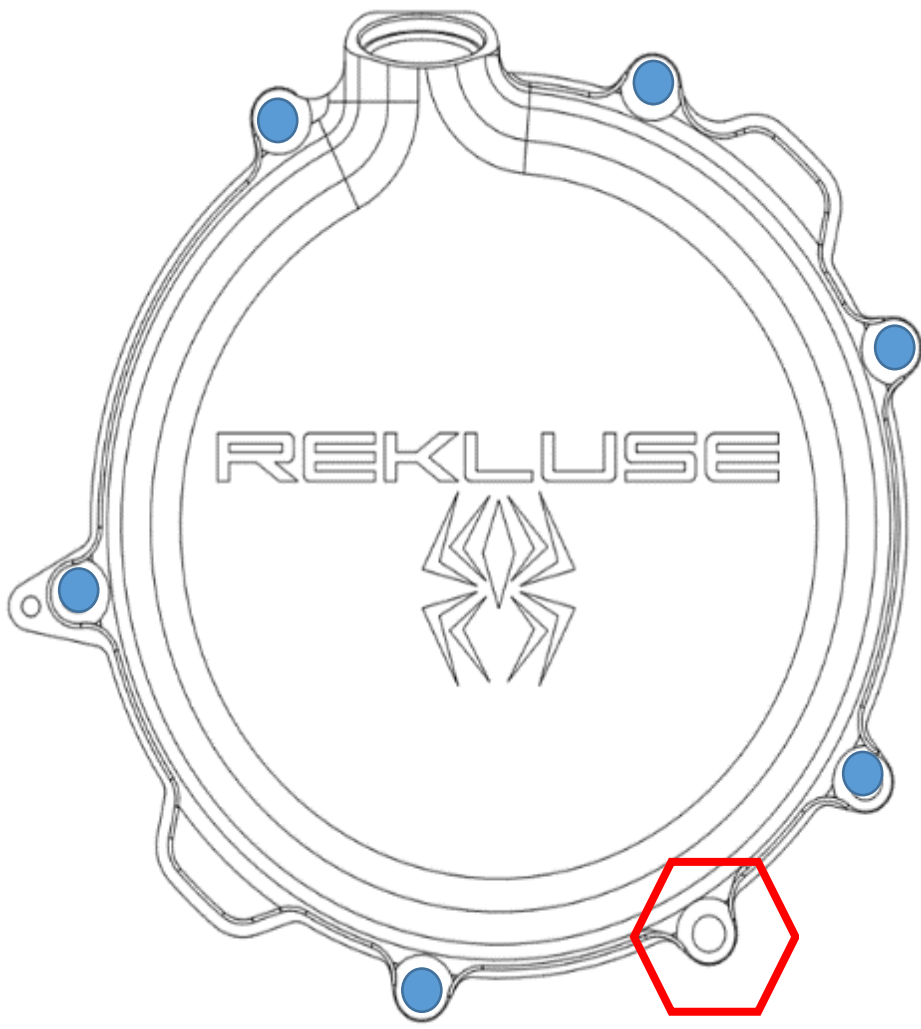
Failure to install the OEM clutch cover bolts back in there proper location can result in damage to your motorcycle.



-  --OE bolts
-  --Rekluse bolt

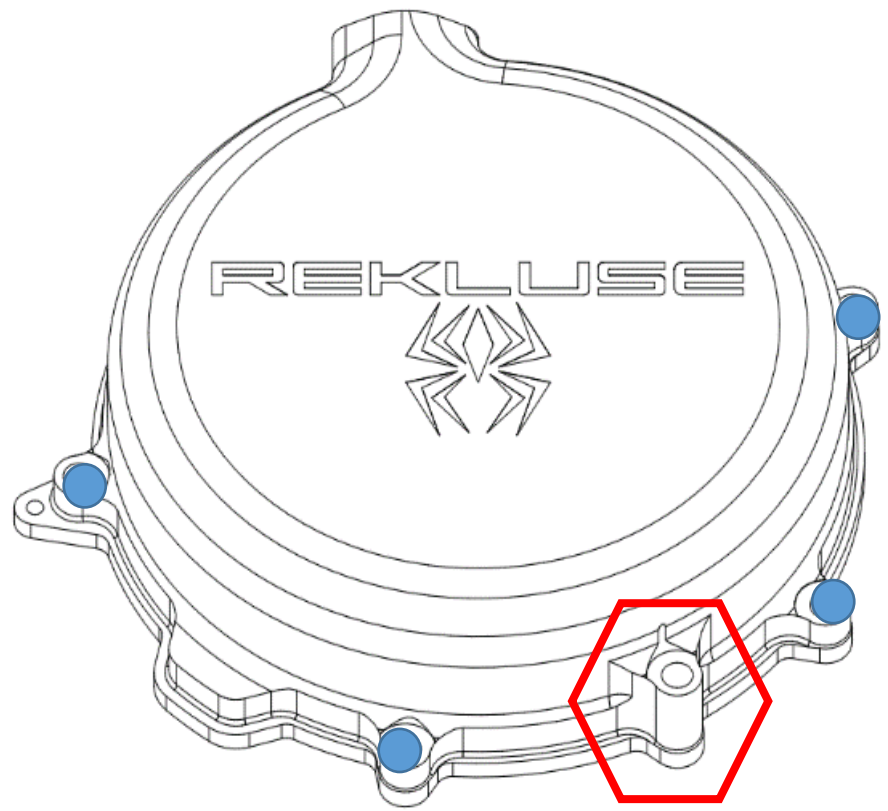

SLAVE CYLINDER INSTALLATION

Installing the new Rekluse slave cylinder takes several steps. Please read the entire section before beginning the process to ensure you have the right equipment and clutch fluid needed for the replacement. Rekluse recommends wearing gloves and safety glasses for the install.

⚠ CAUTION

During the bleed and assembly, note that there is a small ball bearing installed in the slave piston with a small amount of grease. When installing the Rekluse slave cylinder, make sure the ball is in place and has not come loose.

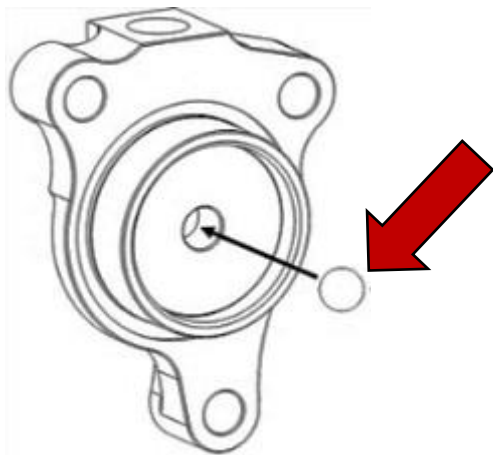

Step 1: Bleed the new slave cylinder

This step prepares the new slave cylinder for installation. Bleed the cylinder on a workbench or an area away from the bike.

1. Using a 4 mm Allen wrench, turn the adjuster screw counterclockwise so that the top O-ring is visible under the adjuster screw.

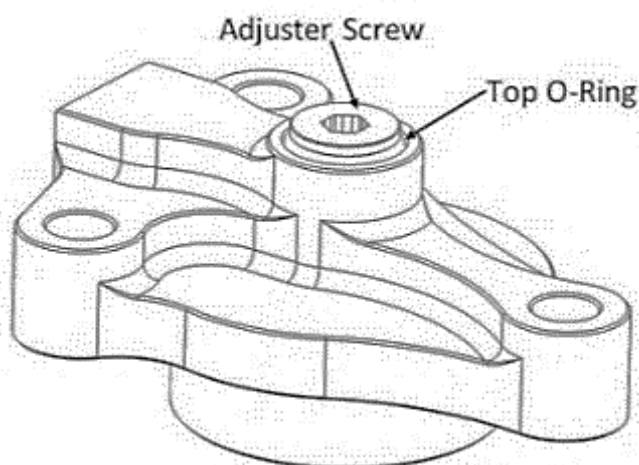

2. Use your thumbs to compress the piston until it bottoms out, then release it.

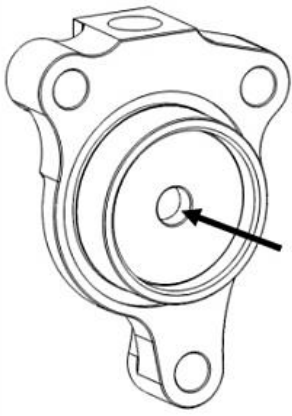

3. Pour the recommended clutch fluid into the slave cylinder port.



⚠ CAUTION

Be sure to use the correct clutch fluid. Check the cap of the clutch master cylinder to determine which clutch fluid to use. Failure to use the correct fluid will result in seal damage and/or failure.

4. Use a 4 mm Allen wrench to turn the adjuster screw clockwise until it bottoms out and the O-ring is no longer visible. Keep the fluid topped off as you go.

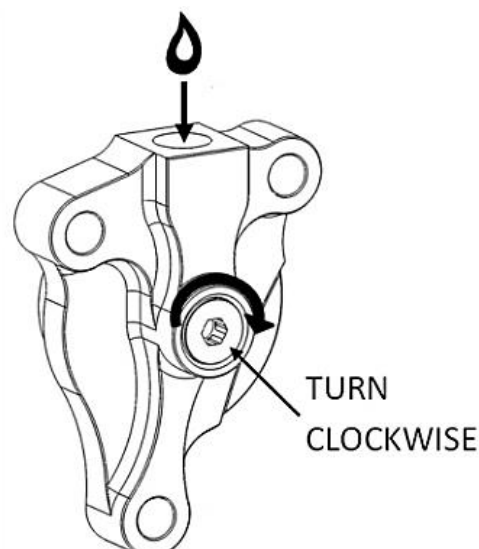

5. Use the wrench to turn the adjuster screw counterclockwise back to the initial position, with the top O-ring visible. Keep the fluid topped off as you go.

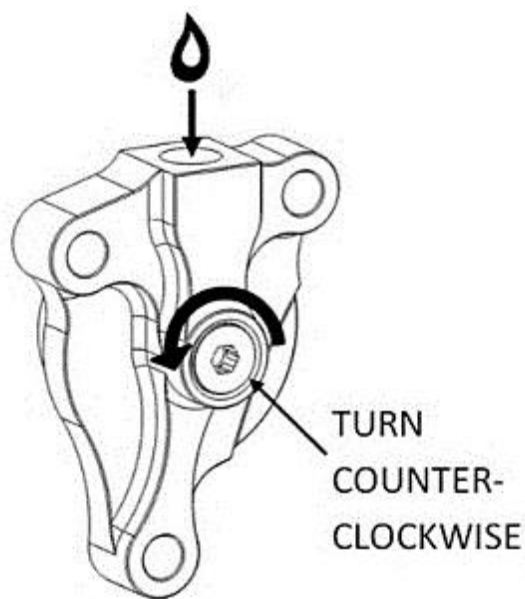

6. Use your thumbs to compress the piston again until it bottoms out while looking for air bubbles.

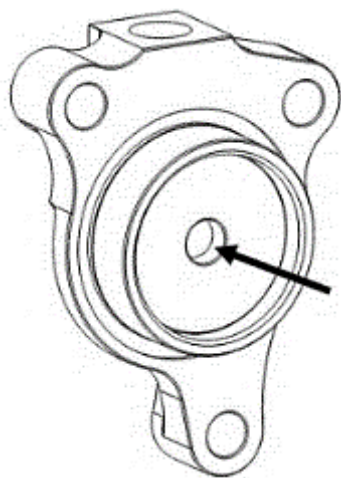

⚠ CAUTION

When compressing the piston, fluid can shoot out from the slave cylinder port. Be sure to wear eye protection.

7. Repeat steps 3 - 6 until there are no air bubbles coming out in the fluid when the piston is compressed.
8. When the bleeding is complete, turn the adjuster screw counterclockwise so that the top O-ring is visible.
9. Compress the piston until it bottoms out, and top off with fluid.

10. Check that the ball bearing is still in place. Stand the Rekluse slave cylinder in an upright position (so the fluid does not spill) until it is needed in the next step.

Step 2: Replace OE slave cylinder

In this step, the OE slave cylinder is replaced with the Rekluse slave cylinder. Work quickly when performing the following steps. This method retains the fluid inside the line, and makes the final bleeding step easier.

1. Stand the bike up and lean it on its kickstand, or place it on a suitable bike stand.



NOTICE

If you are installing on a 350 Freeride bike model, see the Slave Cylinder Appendix sheet for proper install instructions.

2. On the left side of the bike, while leaving the OE slave cylinder intact on the engine, use a wrench to remove the banjo bleeder bolt from the OE Slave cylinder.

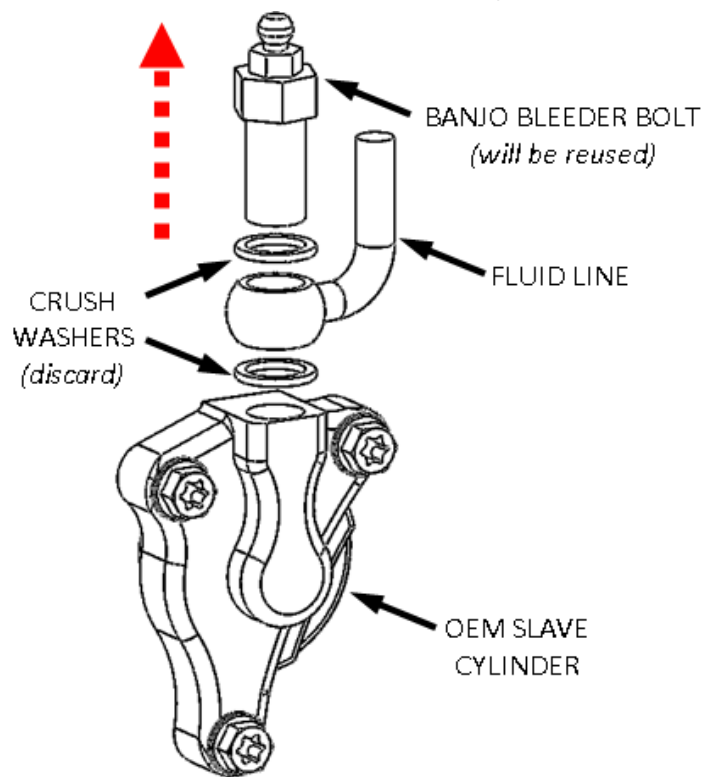

3. Separate the OE slave cylinder from the clutch fluid line.
4. Remove and discard the 2 OE crush washers.
5. Attach the clutch fluid line to the Rekluse slave cylinder using the OE banjo bleeder bolt and the 2 crush washers from Rekluse. Make sure the clutch fluid line is between the 2 crush washers.

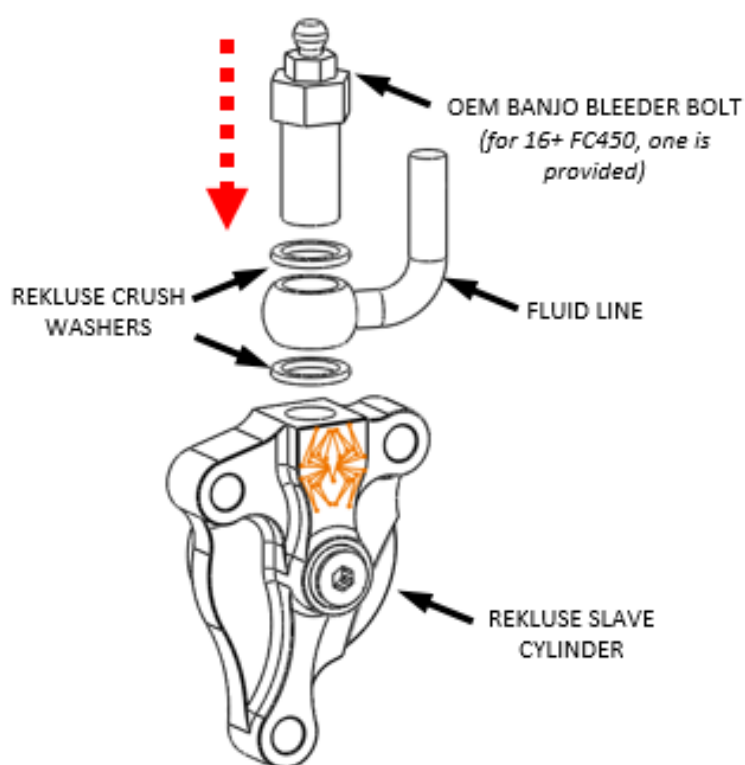

6. Tighten the banjo bolt with your hand until snug. (You will torque it to spec once installed on the bike.)

7. With the clutch fluid line attached to the Rekluse slave cylinder, remove the OE slave cylinder from the engine. Keep the OE bolts for reuse.

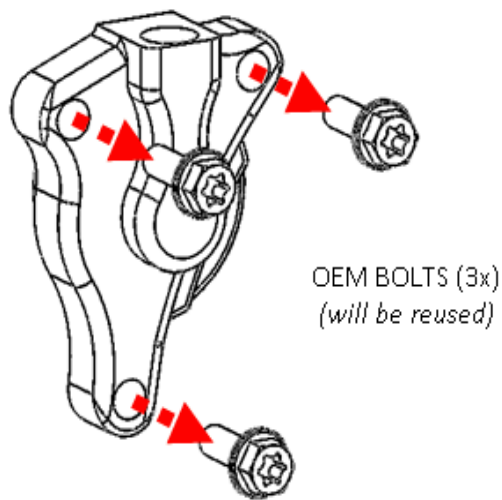

8. Mount the Rekluse slave cylinder to the engine using the OE bolts.

NOTICE

Some models have a piston diaphragm seal. DO NOT reuse them if OE equipped. The Rekluse slave cylinder does not require a diaphragm seal.

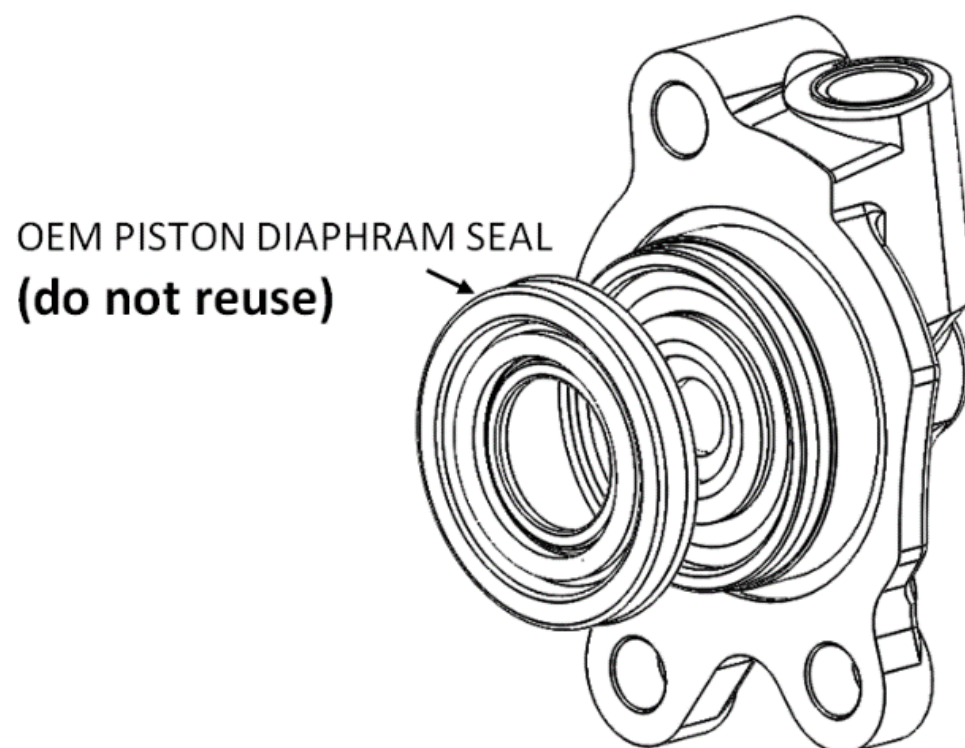

NOTICE

The Rekluse slave cylinder comes preassembled in the kit. If the parts are separated, assemble them in the following order: Rekluse slave cylinder, O-ring (the one supplied or OE), then the supplied paper gasket. Not all slave cylinders come with a gasket. If not supplied, use the OE gasket.

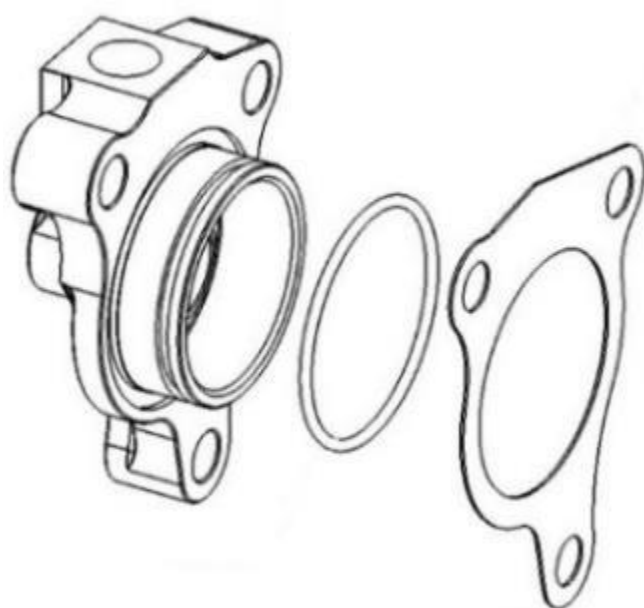

NOTICE

If you need to install the case sealing O-ring seal (OE or Rekluse supplied), make sure it is seated against the slave cylinder flange.

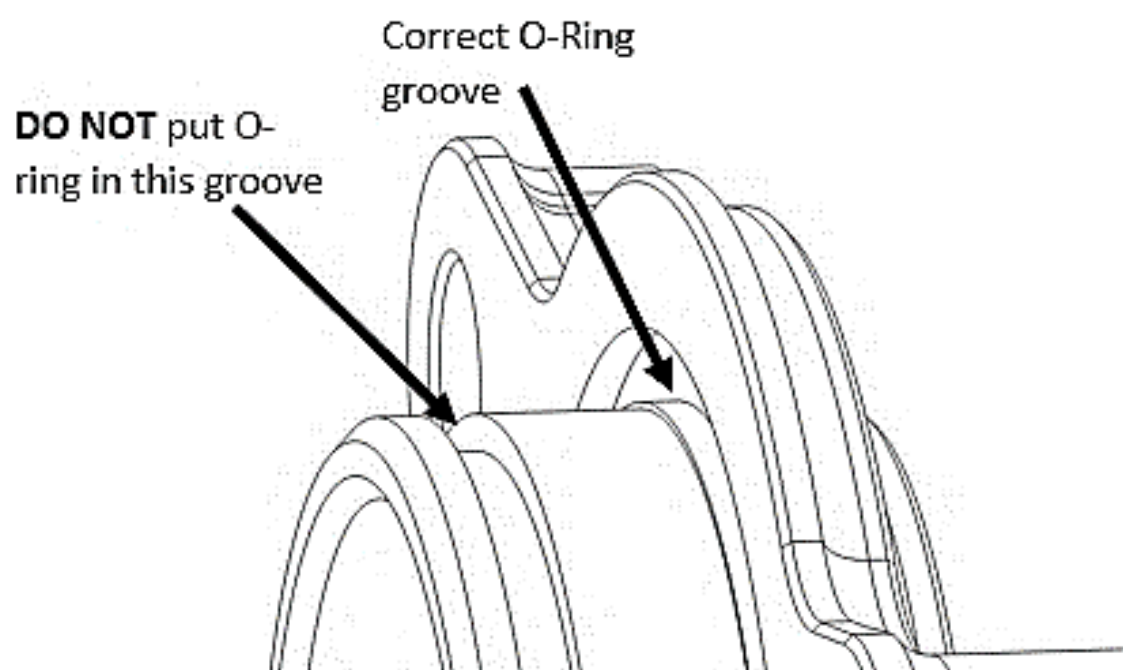

9. Torque the banjo bolt to OE specification.

Optional: If you purchased the Rekluse Slave Guard accessory, install it now using the specific instructions included with the slave guard kit.



BLEED THE CLUTCH LINE

1. Attach one end of the supplied bleed tube to the banjo bolt port, then loop the opposite end into a suitable catch bottle.

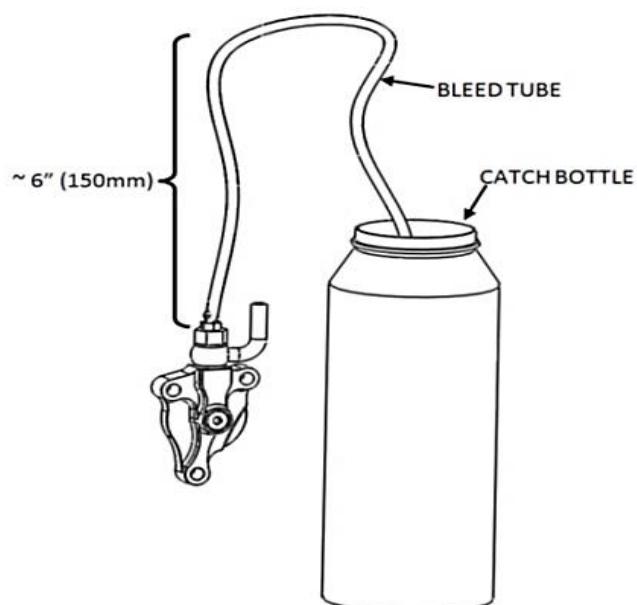

2. On the handlebar, remove the cap and bladder from the clutch master cylinder. Adjust the reservoir so it is level with the ground.

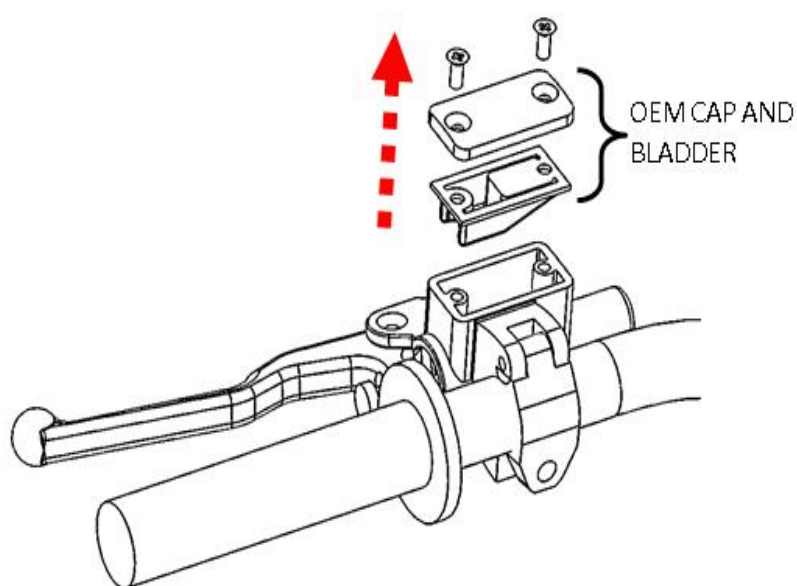

3. Top off the master cylinder with the recommended clutch fluid until it is 75% full.
4. Pump the clutch lever 3 to 5 times, then hold it against the handlebar/grip.

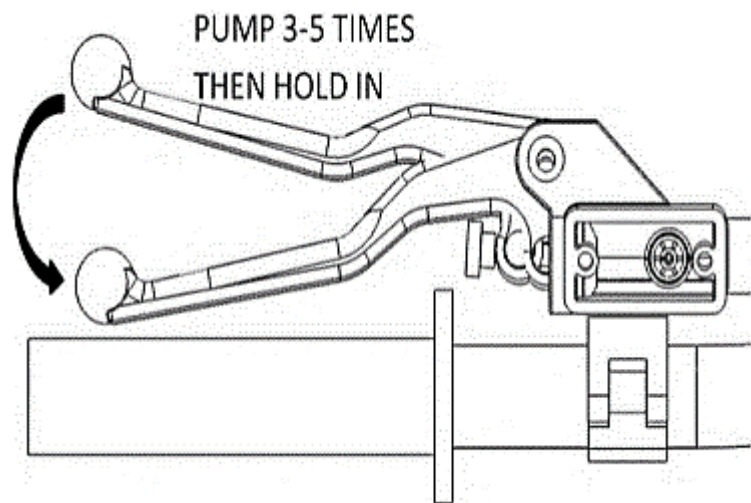

5. While still holding the clutch lever in, use a wrench to open the bleed port. Air and fluid should flow from the bleed tube.

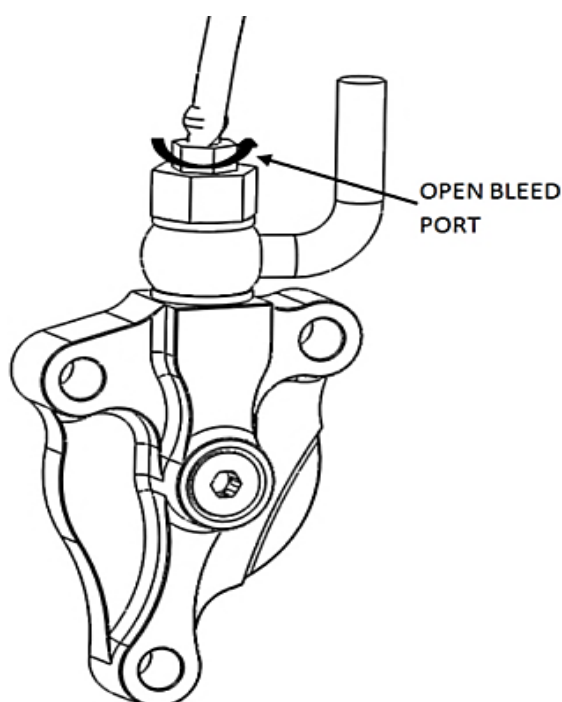

6. Before releasing the clutch lever, tighten the bleed port when the pressure is released from the bleed tube.
7. Slowly release the clutch lever and check the fluid level in the clutch master cylinder. Top off if necessary.

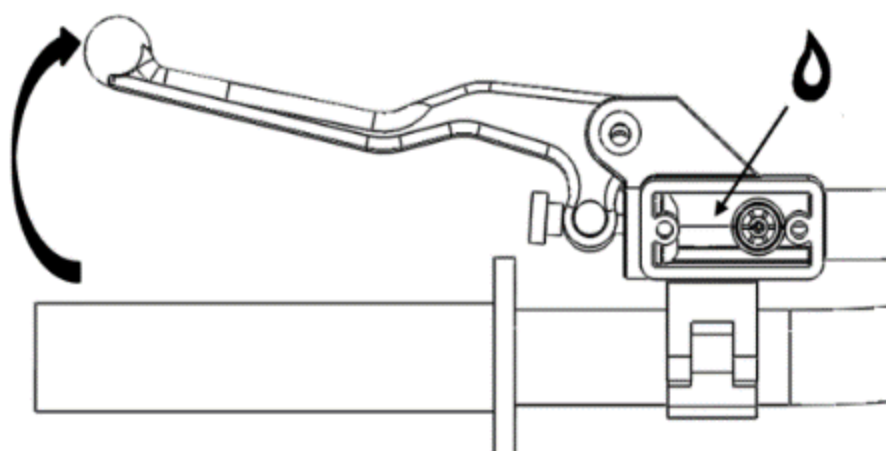

8. Repeat steps 4 - 7 until air no longer comes out of the bleed tube and the clutch feels normal.
9. Check that the clutch master cylinder is 75% full, then replace the cap and bladder.
10. Remove the bleed tube from the bleed bolt and remove the bottle.

SET THE INSTALLED GAP AND VERIFY BY CHECKING FREE PLAY GAIN

It is very important that you understand how to set the installed gap in your new clutch, and be able to verify the installed gap by checking Free Play Gain.

Setup, break-in, and rechecking the installed gap is **CRUCIAL**. Failure to properly maintain your installed gap can result in premature wear or failure of your clutch.

The “installed gap” is the free space in the clutch pack when the EXP disk is disengaged (collapsed). This gap allows the clutch to spin freely until the engagement RPM is reached and the EXP disk expands to close the gap and apply pressure to the pressure plate, which in turn drives the motorcycle forward.

The installed gap is what allows the auto function of the product to perform properly. Use the following steps to set the installed gap and check the Free Play Gain.

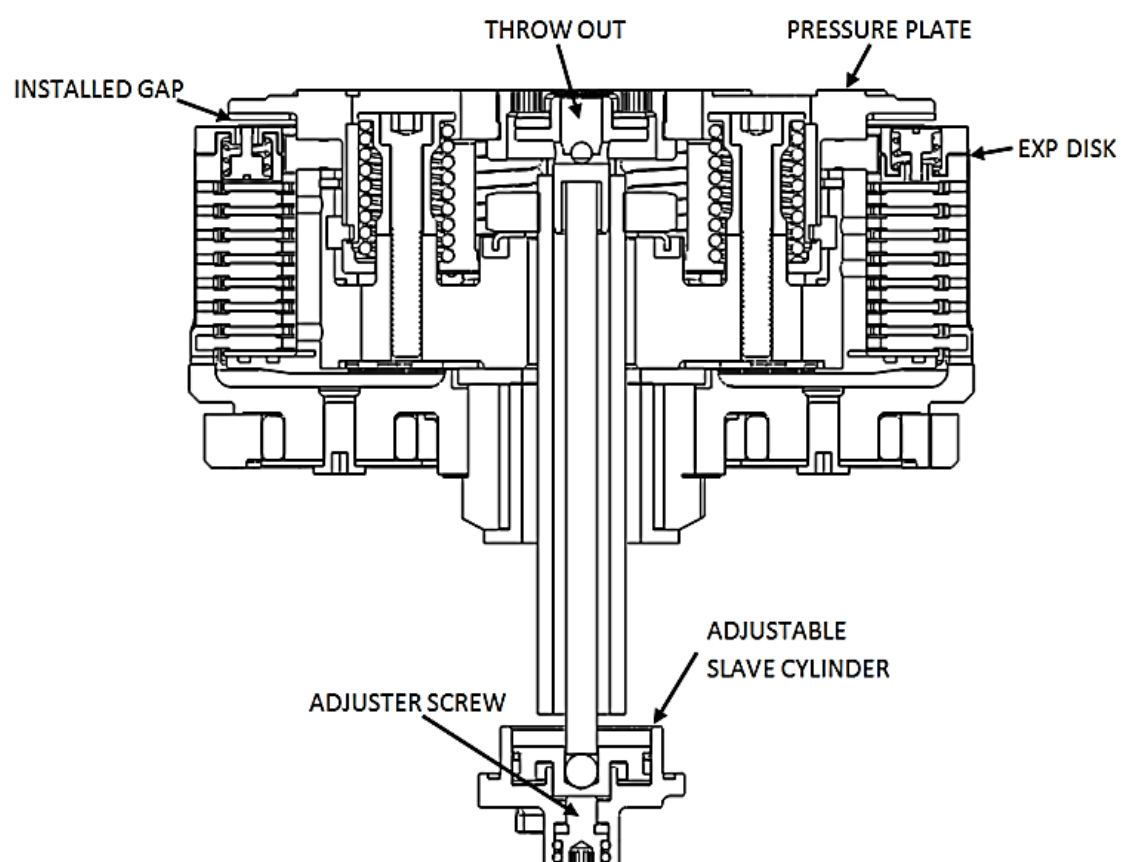

⚠ WARNING

Failure to check and verify Free Play Gain can cause failure or damage to this product. Setting the correct installed gap is critical for clutch performance.

Setting the installed gap and checking Free Play Gain is a 4-step process. It is important to follow each step to ensure that your new clutch functions as designed.

Step 1: Find the starting point

- a) With the bike standing up, locate the adjuster screw in the center of the adjustable slave cylinder.
- b) With the O-ring showing, use a 4 mm Allen wrench to turn the adjuster screw clockwise until it stops under light pressure. This is your “starting point.”

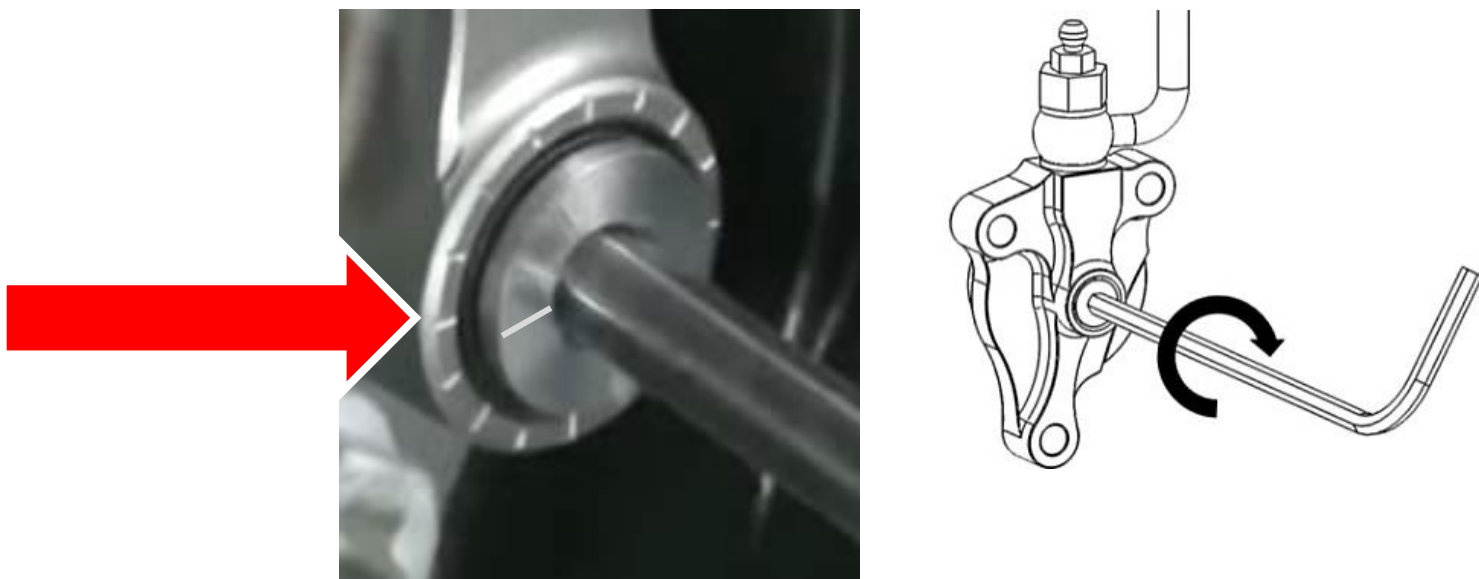

NOTICE

The resistance you feel is where the throw-out begins to lift the pressure plate. Finding the right starting point may take a few tries, but you will feel a noticeable change in turning effort once you reach that point. Stop when you feel the pressure increase. The “starting point” will change as the clutch pack wears over time.

- c) Once you have found the starting point, note the position of the Allen wrench using the tick marks on the slave cylinder housing and the small etch mark located on the screw. You will begin here to adjust the installed gap.

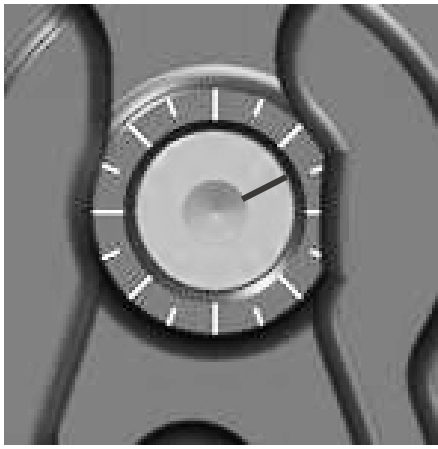

Use the tick marks on the cylinder and the etch mark on the screw to remember the starting point for adjusting the gap.

- d) Use a 4 mm Allen wrench to turn the adjuster screw clockwise 1 full turn + 2 tick marks from your starting point. **This may NOT be your final setting**, but it is a beginning adjustment for finding the correct setting.
- e) Continue with Step 2 to check for Free Play Gain.

⚠ CAUTION

Do not ride your bike without the adjusting the installed gap. You will not be able to disengage the clutch until you set the installed gap.

Step 2: Learn how to check Free Play Gain

Feeling Free Play Gain with the beginning adjustment to the slave cylinder aids in learning to recognize Free Play Gain.

If you are familiar with Free Play Gain, you can skip to Step 3 - "Break-in the new clutch." If Free Play Gain is new to you, follow the instructions below to help you learn this important step. You can also view the video entitled "How to Check Free Play Gain" on our website at www.rekluse.com/support/videos.

Free Play Gain is different from the "normal" free play you are used to with your stock clutch. With the Rekluse auto clutch, Free Play Gain is the result of the EXP disk expanding and lifting the pressure plate to engage the clutch.

Free Play Gain happens when the engine's RPM increases from idle to above approximately 5,000 RPM and the EXP closes the

installed gap. The amount of Free Play Gain you feel in the lever corresponds to the amount the pressure plate has been lifted by the EXP disk expansion.

Checking Free Play Gain allows you to externally monitor the installed gap so you can know when to make an adjustment if the installed gap is too large or too small.

The correct installed gap is verified by observing and feeling the increased free play movement in the clutch lever. This extra movement is called “Free Play Gain.”

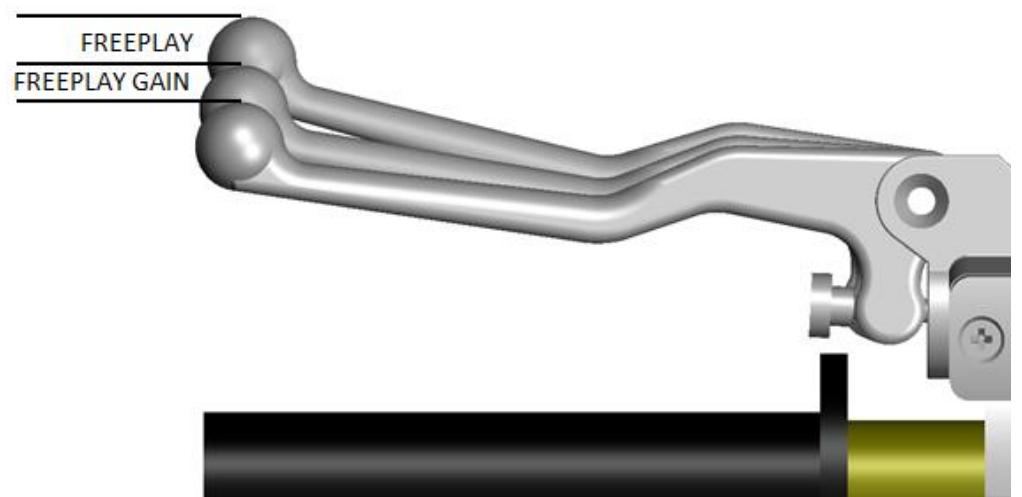

If there is too much Free Play Gain, the installed gap is too small. The bike may drag and stall because it has difficulty disengaging the clutch. It may also be difficult to shift. Too much Free Play Gain will not hurt the clutch, but it will negatively affect clutch performance.

With too little or no Free Play Gain, the installed gap is too large. This means when the EXP is fully expanded it does not lift the pressure plate. The clutch may slip and make the bike seem like it is losing power. The bike may not move forward even though the engine RPM increases as if the clutch lever is slightly pulled. Too little Free Play Gain will cause the clutch system to burn up.

Optimal Free Play Gain yields 1/8” (3 mm) of clutch lever movement, measured at the ball end of the lever. This measurement at the lever correlates to achieving the ideal installed gap.

Two Ways to Check for Free Play Gain

The following steps explain **2 ways** to check Free Play Gain. One way uses the rubber band Rekluse includes in the clutch kit, and one uses your hand. You can use either method to check for Free Play Gain.

Rekluse recommends that you begin with the rubber band method first to check for Free Play Gain and then learn the hand method. The rubber band will help you learn how to recognize Free Play Gain until you are comfortable with the hand method. Learning to check Free Play Gain by hand effectively and comfortably can make it easy to check Free Play Gain every time you ride.

The Rubber Band Method

Use the rubber band method for the initial set up. It can also be used before each ride until you feel comfortable checking the Free Play Gain using the hand method.

⚠ WARNING

BEFORE YOU BEGIN, verify that the bike is in NEUTRAL before checking Free Play Gain. Failure to do so may result in the bike lurching forward, and loss of control and/or injury may result.

A Rekluse auto-clutch can make your motorcycle appear to be in neutral when in gear, even when the engine is running and clutch lever released.

Motorcycles equipped with a Rekluse auto-clutch can move suddenly and unexpectedly and cause riders to lose control. To avoid death, serious injury, and/or property damage, always sit on the motorcycle to start it.

- a) Before you begin, place the bike in **NEUTRAL**, start the engine and let it warm up for 2-3 minutes to idle down and warm the engine oil.

- b) Stretch the included rubber band between your thumbs, then place the top end of the rubber band on the outer end of the left handlebar grip.



- c) While holding the top end of the rubber band against the handlebar, stretch the band downward, then loop it through itself.



- d) Pull the band through the loop, then attach it to the outside end of the clutch lever. This will take up the initial free play (slack) and put the lever in a position to detect the Free Play Gain.



- e) While still in **NEUTRAL**, quickly rev the engine between 5,000-7,000 RPM (1/2 to 3/4 throttle), then let it return to idle. Notice the movement in the clutch lever when the engine is revved. This is your Free Play Gain.

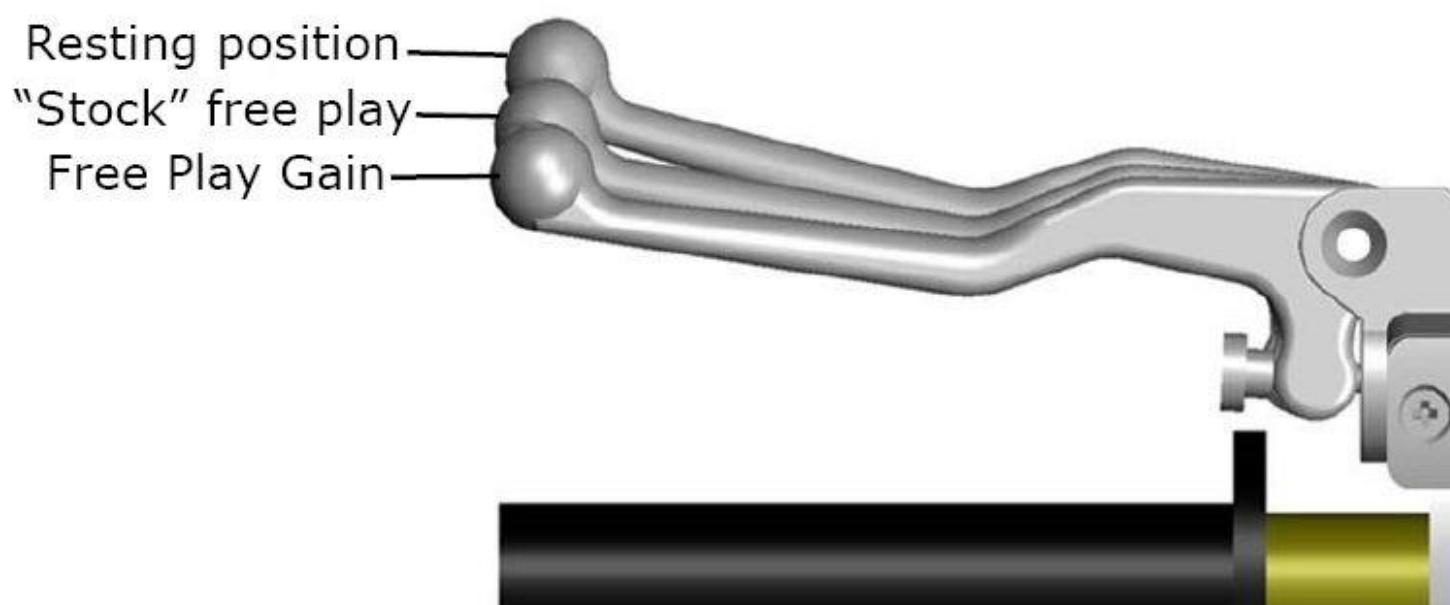

NOTICE

It is very important the motor returns to idle before revving the engine again or Free Play Gain will not be correct.

- f) When the bike returns to idle, rest your hand across the clutch lever. Rev the engine again to 5,000-7,000 RPM so you can observe the movement while feeling for Free Play Gain with your hand.

The Hand Method

Use the hand method to check Free Play Gain before the start of every ride for optimum performance and longevity of your new clutch.

- a) Before you begin, place the bike in **NEUTRAL**, start the engine and let it warm up for 2-3 minutes to idle down and warm up the engine oil.
- b) With the bike at idle, apply enough pressure to the clutch lever to take up the initial free play (slack) in the clutch lever.



c) While still in **NEUTRAL**, continue to apply light pressure and quickly rev the engine between 5,000-7,000 RPM (1/2 to 3/4 throttle), then let it return to idle. Notice the movement in the clutch lever when the engine is revved. This is your Free Play Gain.

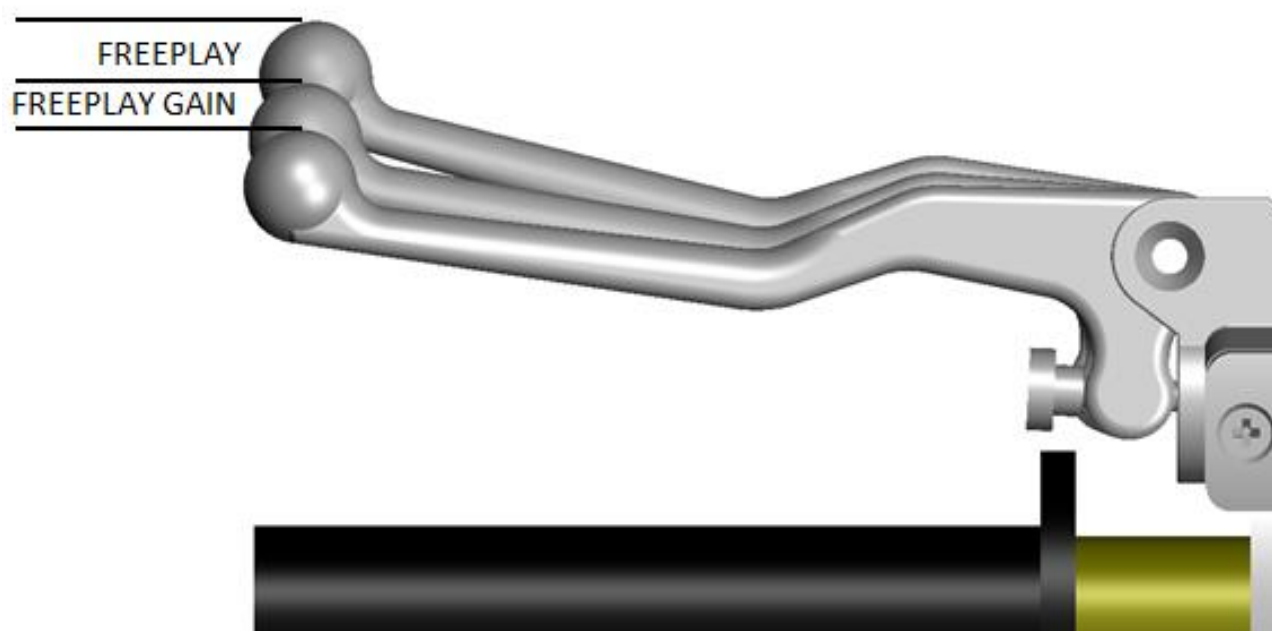

d) When the bike returns to idle, rev the engine between 5,000-7,000 RPM a second time to feel the Free Play Gain again.

e) Continue with Step 3 to break-in the new clutch.

NOTICE



The lever may move more than 1/8" (3 mm) toward the handle when the engine is revved because there is too much Free Play Gain (movement of the clutch lever). This changes as you adjust the installed gap.



Step 3: Break-in the new clutch

Once you install your new clutch, it is important to break it in. A series of roll-on starts are used to break in the clutch. Follow these procedures for breaking in your clutch and any time new friction disks, EXP bases, or wedges are installed.

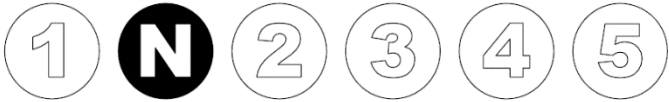
⚠ WARNING

Failure to follow the break-in procedure and oil screen inspection process could cause motor oil delivery failure which can result in motor failure, serious injury, or death.

Break-in Procedure	Number of times
<p>Rev Cycles:</p> <ol style="list-style-type: none"> Place the bike in NEUTRAL. With your hand off the clutch lever, rev the engine 10 times, being sure to let it return to idle between each rev cycle. <p style="text-align: center;">  </p>	<p>10 rev cycles</p>
<ol style="list-style-type: none"> With the engine still running, pull in the clutch lever, then click the bike into 1st gear. Slowly release the clutch lever. The bike should stay in place or have a slight amount of forward creep. <p style="text-align: center;">  </p> <ol style="list-style-type: none"> With the bike idling in first gear, slowly apply throttle to begin moving. Without using the clutch lever, accelerate moderately to approximately 5,000 RPM to fully lock up the clutch and come to a complete stop. Repeat 10 times. <p>NOTICE</p> <p><i>If the engine wants to stall or the creep is excessive, the idle may be too high or the installed gap may be too small. Make necessary adjustments before proceeding.</i></p>	<p>10 roll-on starts</p>

<p>6. Without using the clutch lever, start in 2nd gear, then accelerate moderately to approximately 5,000 RPM and come to a complete stop. Repeat 10 times.</p> <p style="text-align: center;">  </p>	<p>10 roll-on starts</p>
<p>7. Place the bike in NEUTRAL and recheck Free Play Gain.</p> <p>8. Continue to step 4 to adjust the installed gap until the Free Play Gain of the clutch lever is 1/8" (3 mm).</p> <p style="text-align: center;">  </p> <p>NOTICE</p> <p><i>Your clutch pack will expand with heat, so final adjustment to Free Play Gain should be made when the bike is warm. Remember not to ride without sufficient Free Play Gain.</i></p>	<p>Recheck Free Play Gain and adjust the installed gap</p>
<p>CAUTION</p> <p>Do not perform 3rd gear starts with this product. Starting in 3rd gear will burn up the clutch and decrease the performance of this product in a short amount of time.</p>	

Step 4: Adjust the installed gap and Recheck Free Play Gain

Once you have learned how to check Free Play Gain, you need to finish adjusting the installed gap, then recheck the Free Play Gain

until the clutch lever moves only 1/8" (3 mm). The gap is adjusted by turning the slave cylinder screw.

- a) With the bike running and in **NEUTRAL**, locate the adjuster screw in the center of the adjustable slave cylinder.
- b) Use a 4 mm Allen wrench to turn the adjuster screw clockwise 1 tick mark from the last setting, then recheck Free Play Gain.



Tick marks are located on the slave cylinder, and an etch mark is on the screw. If you need to re-position the Allen wrench, you can use these marks for reference.

- c) Continue to adjust the slave cylinder 1 tick mark at a time until optimal Free Play Gain is achieved.
- d) Refer to the following pictures and chart in the next section for additional adjustment information.
- e) The Free Play Gain will change as the clutch pack wears over time.
- f) Checking the Free Play Gain is easy and indicates when the install gap needs adjusting.

FREE PLAY GAIN ADJUSTMENTS

Make each adjustment in small increments - one tick mark at a time. After each adjustment, recheck Free Play Gain until you achieve the optimal 1/8" (3 mm) of clutch lever movement.



Symptom	Reason	Solution
<ul style="list-style-type: none"> • Clutch lever moves in too far (too much Free Play Gain) • Clutch has excessive drag or stalls • It is difficult to fully override the clutch with the lever 	<p>Installed gap is too small</p>	<p>Turn the adjuster screw clockwise 1-2 marks to increase the installed gap and decrease Free Play Gain. Recheck Free Play Gain.</p>
<ul style="list-style-type: none"> • Clutch lever only moves slightly or does not move at all (too little Free Play Gain) • Clutch slips • Bike seems to lose power 	<p>Installed gap is too large</p>	<p>Turn the adjuster screw counterclockwise 1-2 marks to reduce the installed gap and increase Free Play Gain. Recheck Free Play Gain.</p>

MAINTENANCE

To keep your clutch performing at its best, perform regular maintenance on your bike and clutch.

- Keep up with regular oil changes as per the bike manufacturer's recommendations. Clutch performance and longevity depend on oil quality.

Oil recommendations can also be viewed under Tech Tips on our website at www.rekluse.com/support/videos/atv-mc-support-videos.

- Inspect all of your clutch parts for signs of wear or excessive heat, and replace components as necessary. Clutch wear is dependent on the riders use.

Maintenance Protocol	Maintenance Intervals
Check and verify Free Play Gain	Every ride
Inspect all clutch parts for excessive wear or heat. Replace as needed.	Refer to OE service manual

- The OE spring ring can be optimized based on the wear and height of the clutch pack. See the attached Setup Sheet for the spring ring optimization table to adjust the spring ring.
- Measuring the clutch pack and/or the EXP disk can help determine if the components need replacing. See the Setup Sheet for the specific clutch pack measurements.

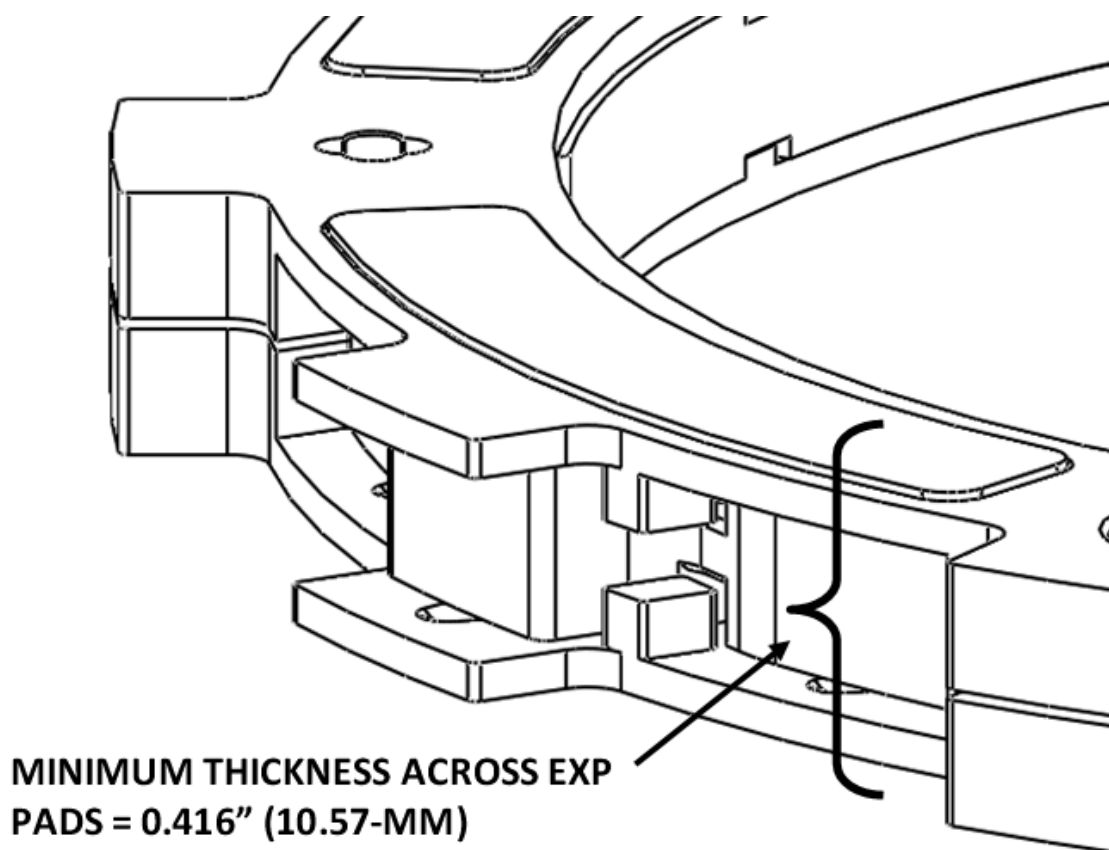

- Inspect the dampers, and replace them if you feel any movement between the two hubs. Refer to the section on inspecting the dampers for more information.
- Maintain adequate Free Play Gain. Check before every ride and adjust if necessary.
- Repeat the break-in procedure anytime you replace the EXP bases, EXP wedges, or frictions disks. Always soak friction disks or EXP bases in oil for at least 5 minutes before installing.
- Replace friction disks if they measure below specifications listed on the attached Setup Sheet or if the disks are glazed and/or burnt.
- Replace the drive plates if they show signs of excessive heat.

Disk inspection examples

When inspecting the clutch pack, the following pictures can be used as a reference. **These are best viewed in color by viewing this install document from www.rekluse.com/support.**

Drive Plates – If the clutch pack is getting high amounts of heat, purple, blue, or black color can be seen on the drive plate teeth. See pictures below. Not all drive plates look the same and may look different than pictured.

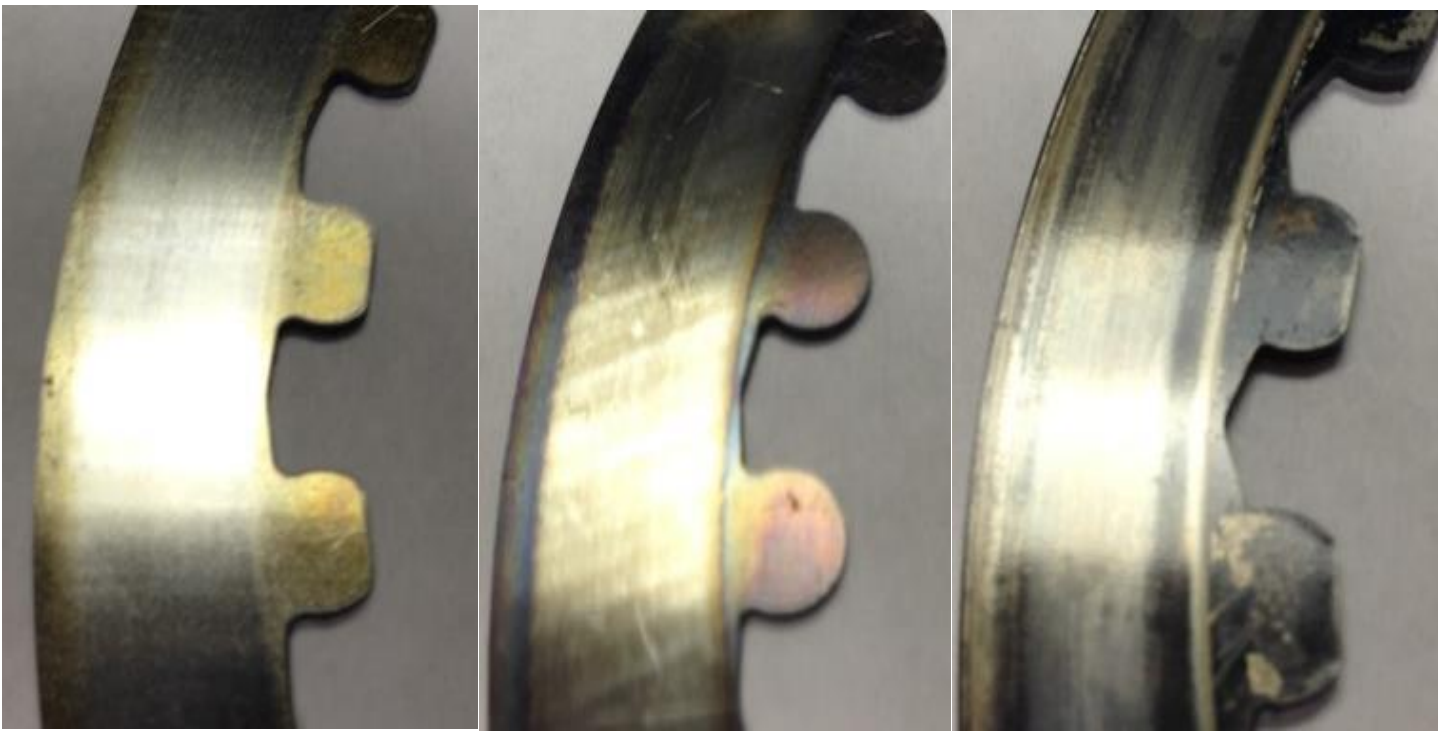

Normal Heat

High Heat
(Blue)

Excessive Heat
(Black)

Friction Disks – Due to the dark color of the friction material, the friction disks will appear almost black as soon as they are put in oil. During inspection, look for glazing of the friction material. Glazing will appear shiny and feel like glass, even after oil is cleaned from the friction disk. Not all friction disks look the same and may look different than pictured.



Normal
Friction



Glazed
Friction

TROUBLESHOOTING

Performance issues

If you find yourself adjusting the slave cylinder to fix Free Play Gain or drag, the clutch disks might be worn. Excessive heat or clutch slip can cause premature clutch failure as well. Once extreme temperatures are reached, irreversible damage will occur.

- Inspect all of your clutch parts for signs of wear or excessive heat, and replace components as necessary. Clutch wear is dependent on the riders use.
- Measuring the clutch pack and/or the EXP disk can help determine if the components need replacing. See the attached Setup Sheet for the specific clutch pack measurements.

Clutch noise

Although it is harmless, some bike models may have “squeal” or “chatter” coming from the clutch at low RPM as it engages. Clutch squeal is caused by the clutch components vibrating as the clutch engages and can become more audible as the clutch gets hot. Adjusting the installed gap will NOT affect clutch squeal or chatter.

For bike models that have clutch squeal or chatter here are some recommendations to reduce or eliminate it:

- Change the oil: For optimal clutch performance Rekluse recommends using fresh, clean oil that **meets JASO-MA** oil rating requirements. Dirty or old oil can make the clutch more likely to squeal or chatter.

EXP TUNING OPTIONS

Adjusting the engine idle speed to match your engagement setting is important and greatly affects the overall feel of how the EXP disk engages. To prevent freewheeling and maximize engine braking, set the idle so there is a slight amount of drag while the bike is

idling in gear and warmed up. The idle should not be so high as to move the bike forward in gear with the throttle closed. However, with a small opening of the throttle the bike should move forward.

You can tune the engagement RPM of the EXP disk by changing the spring configuration. The EXP disk comes set with the recommended “**Medium**” setting from Rekluse. Use the following steps to change the springs. It is **NOT necessary** to disassemble the EXP halves to change springs!

Changing the springs

1. Using a flat-blade screwdriver, push the ¼ turn pin in far enough to clear the opposite side of the EXP to unlock the pin.
2. With the pin still pushed past the base, turn 90° to remove the pin and spring.
3. Remove the remaining 2 pins and springs from the same side of the EXP base.
4. Drop a new spring into the spring slot on the base, then add the ¼ turn pin.
5. Push the turn pin in far enough to clear the base, then turn 90° and release the pin. The pin should sit almost flush with the EXP base.
6. Flip the EXP friction disk over, and repeat on the other side depending on engagement preference.
7. If you need to disassemble the EXP disk, you can watch the video on our website under Tech Tips at www.rekluse.com/support/videos/atv-mc-support-videos.

NOTICE

To maintain even pressure, when using two different color spring sets, install one set of 3 on one side of the EXP and the remaining set of 3 on the other side.

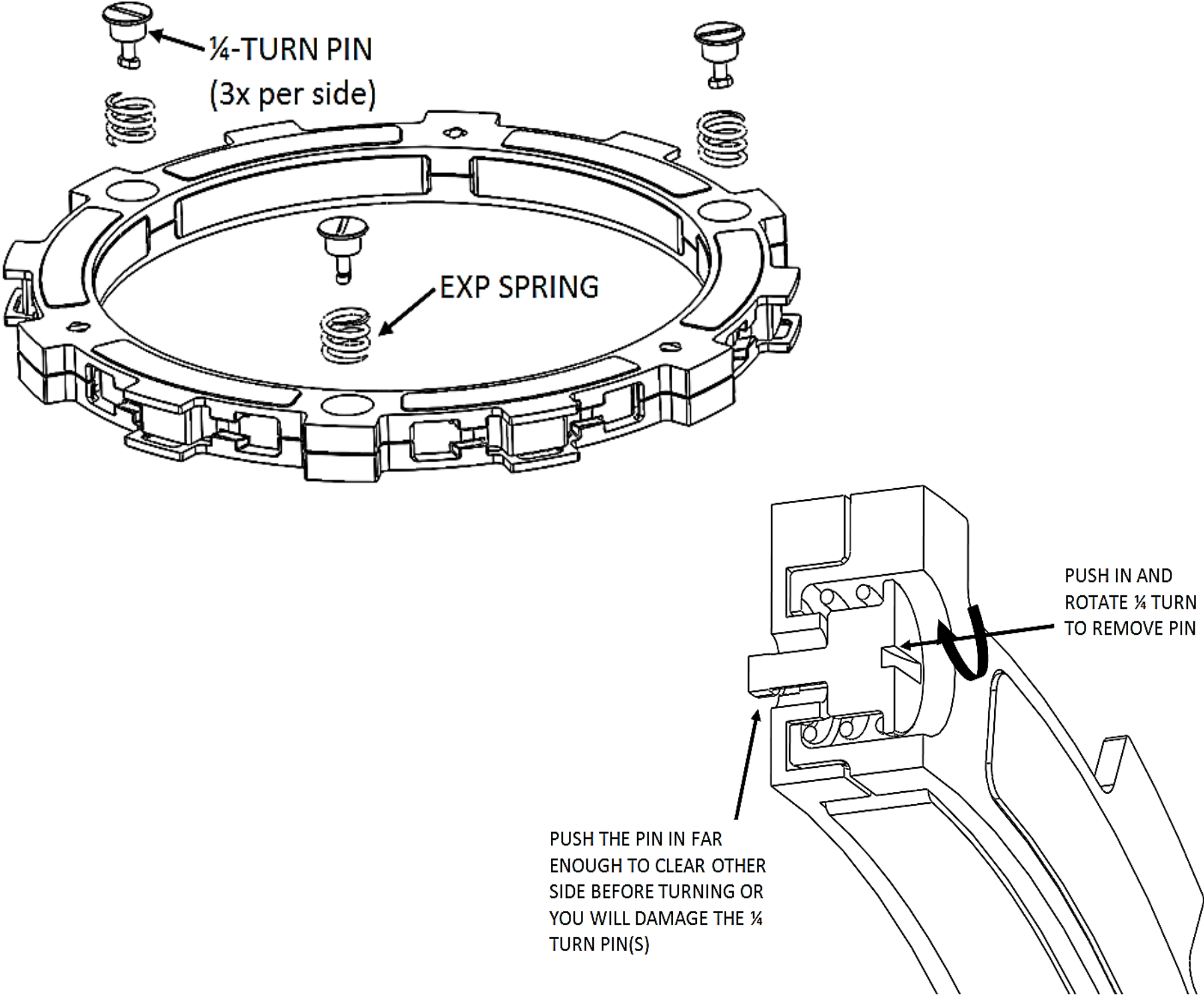

Configuration Chart

LOW SETTING



HIGH SETTING

EXP Springs Settings	
6 Silver	
3 Silver &	3 Red
6 Red	
3 Red &	3 Blue
6 Blue	
3 Blue &	3 Gold
6 Gold	
3 Gold &	3 Green
6 Green	
3 Green &	3 White

BUMP-STARTING

If your bike needs to be bump-started due to a dead battery or any other reason, follow the steps below to quickly bump-start your bike.

1. Turn the adjustable slave cylinder counterclockwise to collapse the gap until no resistance is felt.
2. Bump start the bike. The clutch will function like a manual clutch at this point, but the clutch will not be fully over-ridable at high RPMs.
3. Once the bike is started, readjust the installed gap.

NEED ADDITIONAL HELP?

Website

www.rekluse.com/support

Phone

(208) 426-0659

Monday thru Friday: 8 am – 5 pm Mountain Time

Email

customerservice@rekluse.com



SETUP SHEET 198-7913095

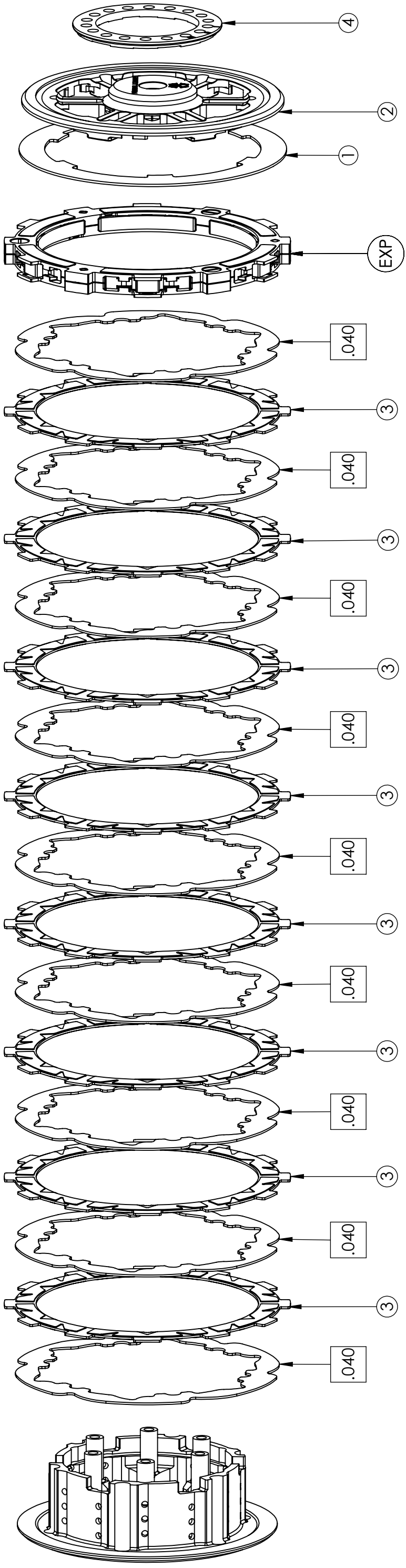

ITEM NO.	DESCRIPTION	QTY.
1	LINING PLATE [.048"/1.2mm THICK]	1
2	PRESSURE PLATE	1
.040	TEC DRIVE PLATE [.040"/1mm THICK]	9
3	TORQDRIVE FRICTION DISK	8
4	OEM Spring Ring	1
EXP	EXP 3.0 BASE - KT350	2

The OEM spring ring has different settings to account for variances in the clutch pack and wear. The optimal setting depends on the thickness of the clutch pack.

In general, MORE preload on the spring results in LESS clamping force, which in turn provides a lighter lever pull and less aggressive clutch performance.

LESS preload on the other hand provides MORE clamping force, a heavier clutch pull, and more aggressive clutch performance.

See the "Spring Ring Optimization Table" for recommended optimized setting based on clutch pack thickness.

PACK THICKNESS [IN/mm]	SPRING RING SETTING
>1.352 (>34.3)	III OR Z
1.341-1.351 (34.0-34.3)	II OR Y
1.311-1.340 (33.3-34.0)	I OR X

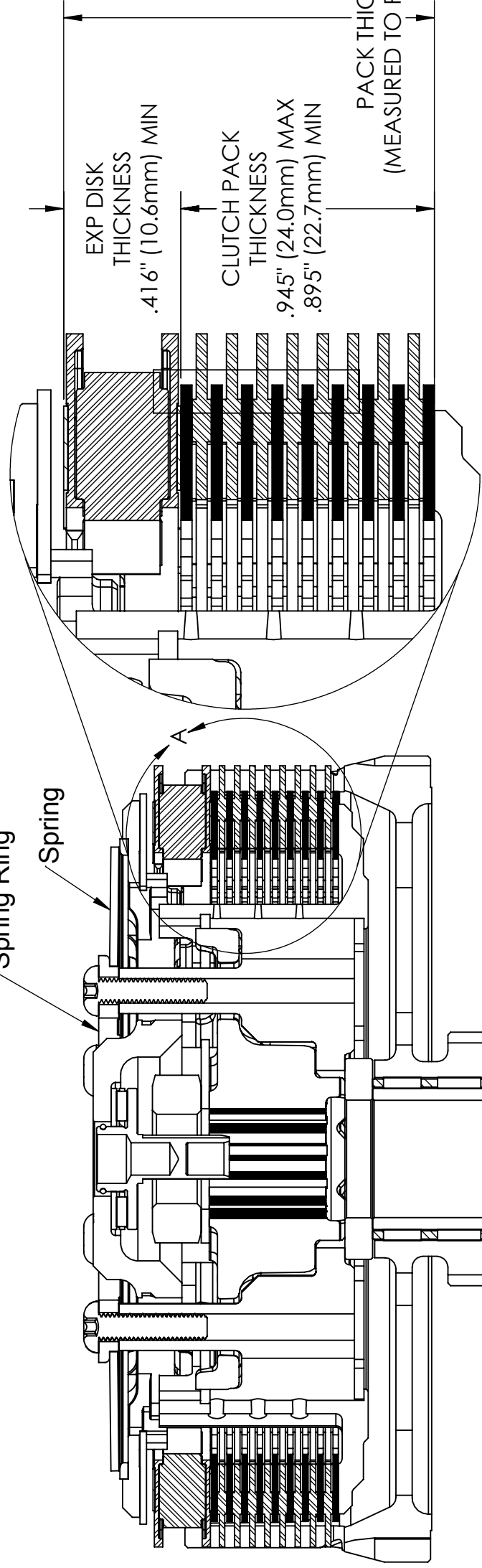

KTM Freeride ONLY

Slave Cylinder Appendix

Due to the KTM Freeride's smaller OEM slave cylinder banjo bolt, the included thread insert needs to be installed into the Rekluse Adjustable Slave Cylinder.

1. Thread the insert into the Rekluse Adjustable Slave Cylinder, using needle-nose pliers, starting with the thread insert tang.

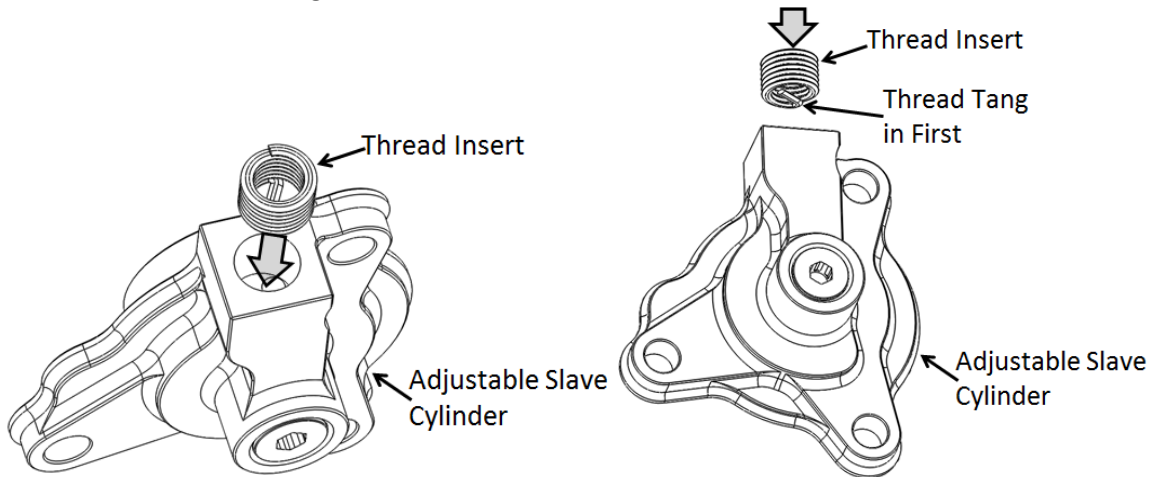

2. Stop when the thread insert is below the top surface of the fluid port. If the insert is not below the surface the crush washers will not seal.

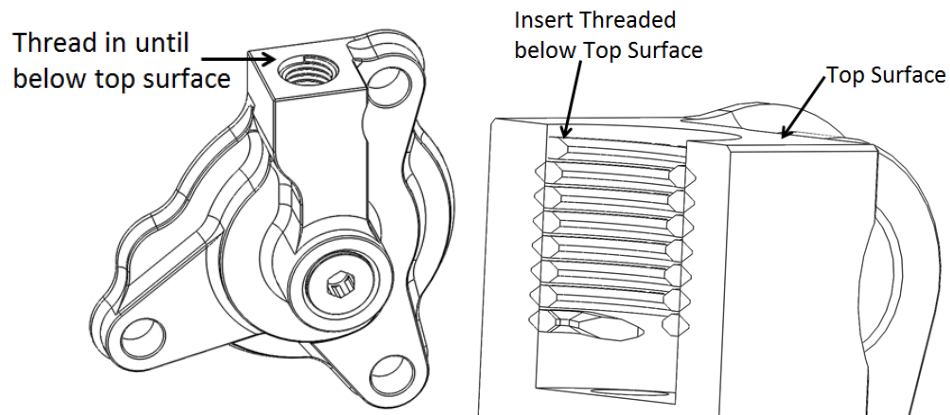

3. Using the needle-nose pliers, bend the thread insert tang up and down until it breaks off and remove it from the adjustable slave cylinder.

