



INSTALLATION & USER'S GUIDE

Doc ID: 191-6306A
Revision: 080923

©2023 Rekluse Motor Sports
Rekluse Motor Sports, Inc.
support@rekluse.com

TABLE OF CONTENTS

OVERVIEW	3
INSTALLATION TIPS	3
TOOLS NEEDED.....	4
INCLUDED PARTS	5
INSTALLATION INSTRUCTIONS	6
DISASSEMBLY AND INSTALLATION	6
INSTALL THE CLUTCH PACK.....	10
SLAVE CYLINDER INSTALLATION.....	17
SETTING THE INSTALLED GAP	27
CHECKING FREE PLAY GAIN	28
RUBBER BAND METHOD	30
HAND METHOD	30
FREE PLAY GAIN TROUBLESHOOTING	31
BREAK-IN PROCEDURE	32
MAINTENANCE.....	33
OPTIMIZING EXP ENGAGEMENT	33
EXP TUNING OPTIONS.....	34
CLUTCH SQUEEL AND CHATTER	35
BUMP-STARTING INSTRUCTIONS	35
NEED ADDITIONAL HELP?.....	36

OVERVIEW

- Read the separate included **Safety Information** document before operating the vehicle with the product installed.
- If you are performing the installation of this product for a customer or another person, instruct them to read the **Safety Information** document and the **Installation and User Guide** before operating the vehicle with the product.
- Read this entire document before performing any steps, so you will know what to expect.
- When reinstalling components, use the torque specifications found in your service manual. Torque values listed are valid as of the date shown in the document revision number above.
- For optimal clutch performance Rekluse recommends using fresh, clean oil that **meets JASO-MA** oil rating requirements. Rekluse offers Factory Formulated Oil™ developed specifically for Rekluse products. Rekluse Factory Formulated Oil is a perfect complement to any OEM or aftermarket wet clutch. Visit www.rekluse.com to learn more.

All OEM components will be reused except:

- This kit will replace all of the OEM frictions and drive plates with a Rekluse thin friction EXP clutch pack. Inspection of OEM components is necessary during installation
- This kit will replace the OEM pressure plate with a Rekluse pressure plate.
- This kit will replace the OEM slave cylinder with a Rekluse adjustable slave cylinder.

Tuning Note: (especially for 2-Stroke owners):





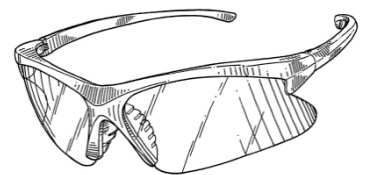

- Upon installation of this product, if you desire your clutch to engage more aggressively, a favorable option is to purchase the heavier Belleville spring from KTM (KTM calls it the “280” spring).
- KTM Part #: 78932005000 This spring will make the clutch engagement more aggressive but will slightly increase the clutch lever pull effort. This spring comes stock on 2013 and newer Factory Edition 450SX-F bikes.

INSTALLATION TIPS

- Protect eyes and skin – wear safety glasses and thin disposable work gloves.
- Inspect your OEM cable for fraying and replace if needed.
- Work in a ventilated area.
- If the motorcycle is a two stroke turn the fuel petcock to “OFF.”
- During disassembly and installation lay the bike on its left side to avoid draining the oil. Do this by placing the handle bar on a center stand. Catch fuel that may drain from vent tubes.

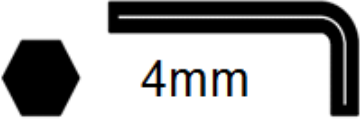
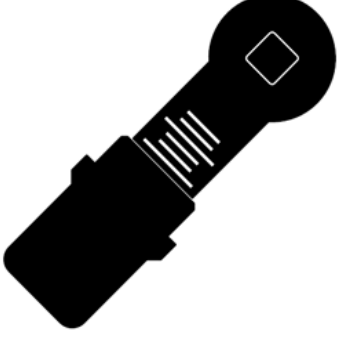

TOOLS NEEDED

	 <p>8 mm</p>	 <p>4mm</p>	
<p>Hydraulic Clutch Fluid</p>	<p>8 mm socket</p>	<p>4mm Allen</p>	<p>Torque wrench</p>
		 <p>T25</p>	
<p>Dental Pick</p>	<p>Metric End Wrench Set</p>	<p>Torx Bit T25</p>	

INCLUDED PARTS

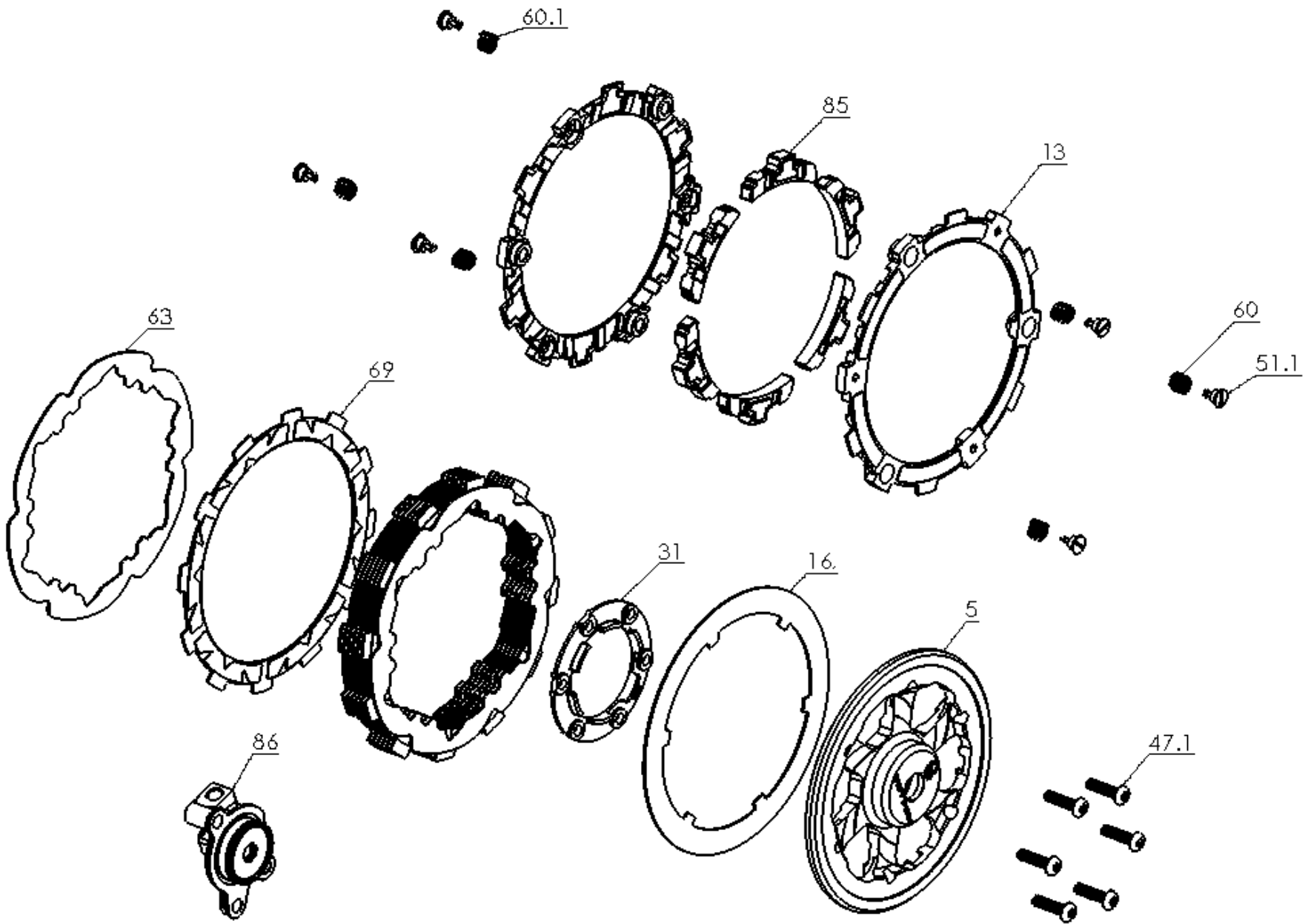

Item	Description	Qty.
5	Pressure Plate	1
13	EXP Base	2
16	Lining Plate	1
31	Pressure Ring Spacer	1
47.1	T-25 Torx Screw	6
51.1	Quarter Turn Pin	6
60	EXP Spring	3
60.1	EXP Spring	3
63	Drive Plate	8
69	Thin Friction Disk	7
85	Wedge Assembly	1
86	Adjustable Slave Cylinder	1
Not Shown	Spacing Gasket	*
Not Shown	Orange FPG Rubber Band	1
Not Shown	EXP Spares	VARIES
Not Shown	Quarter Turn Pin Spares	2
*Parts are only included in products when required. If your kit does not have these part then they are not necessary for installation		

INSTALLATION INSTRUCTIONS

DISASSEMBLY AND INSTALLATION

1. Soak the EXP disk and Torqdrive friction disks in engine oil for 5 minutes.

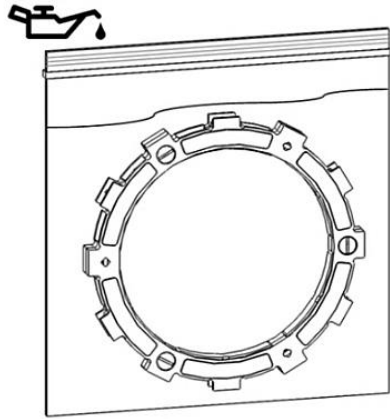

2. If your bike is carbureted, turn the fuel petcock to “OFF” and lay the bike on its left side.

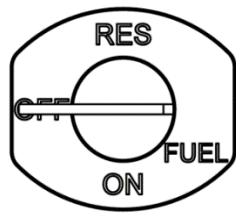

3. Remove the OEM clutch cover



NOTICE

Take note of each OEM clutch cover bolts specific location as length can vary between them. Failure to replace these bolts in the proper location after clutch installation can result in damage to your motorcycle.

4. Remove the OEM parts named in the following diagram. Note the orientation of the Bellville spring.

NOTICE

Throw-out washers can stick to the back of the pressure plate. Be sure to reindex any throw-out washers back onto the throw-out.

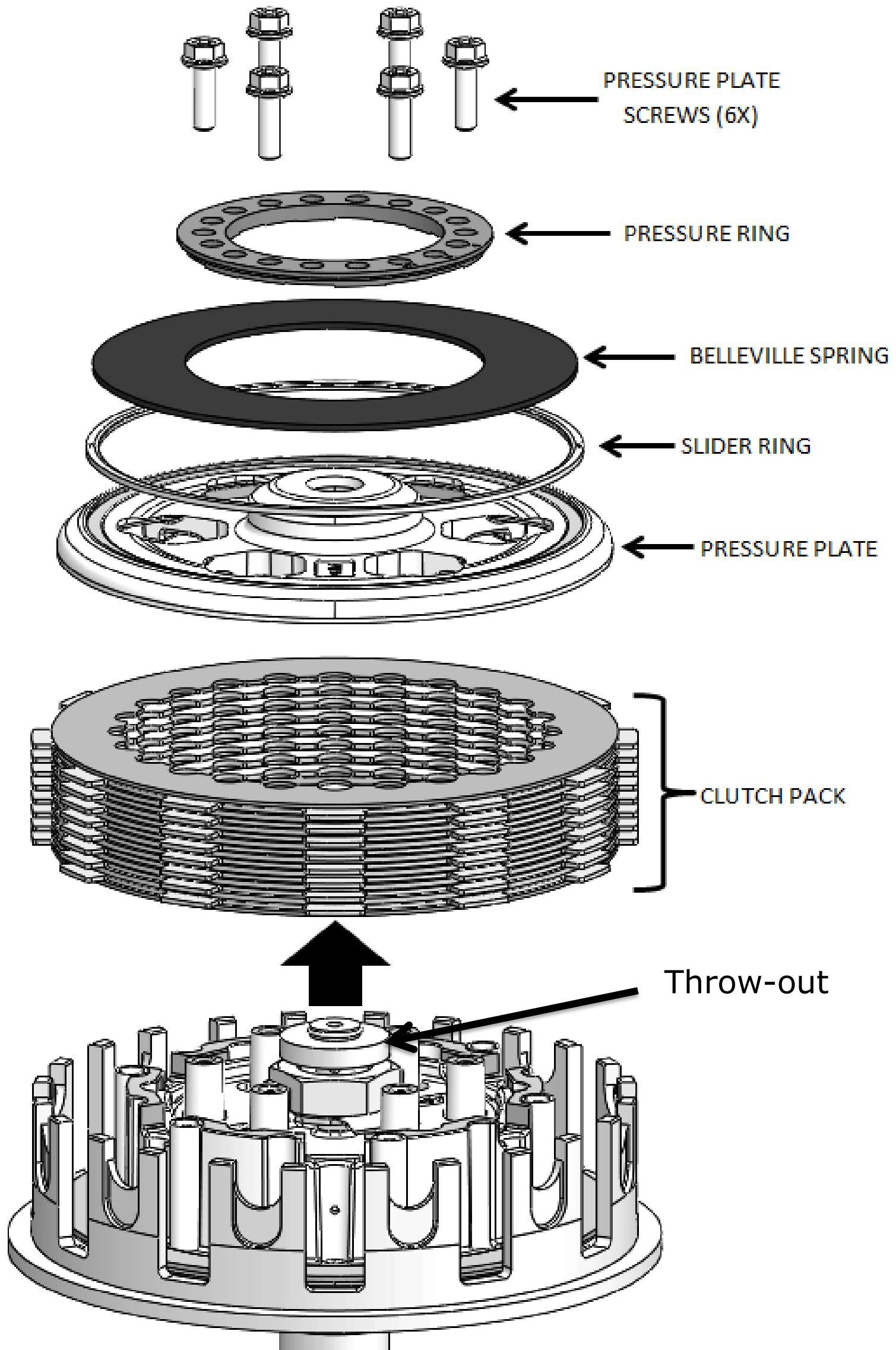

The KTM DDS clutch (a.k.a. Belleville spring clutch) employs a 2-piece damped center hub assembly, as shown. Rekluse clutch products employ the same technology and reuse the OEM rubber dampers.

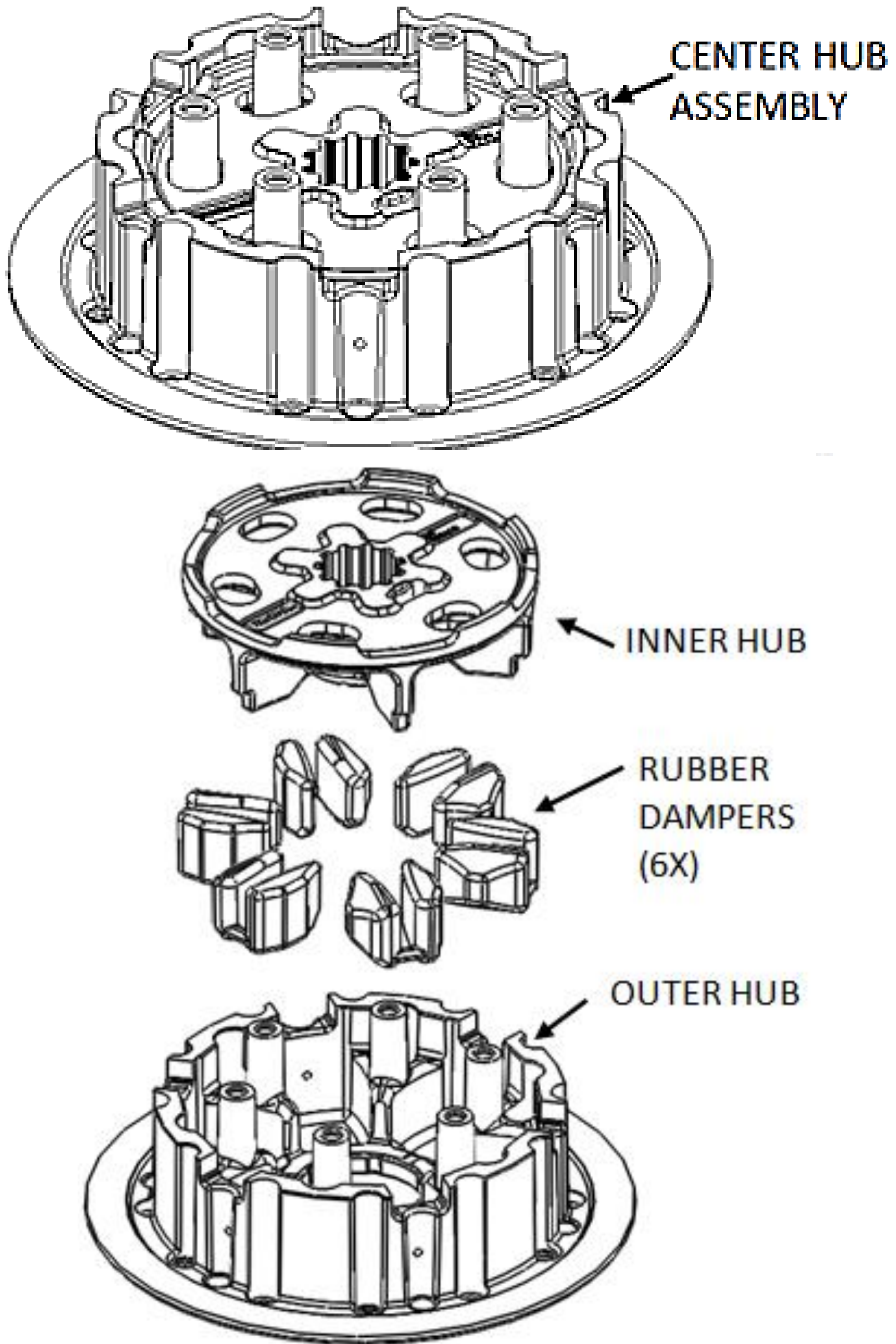

Over time, the rubber dampers will shrink due to heat and use. When this shrinkage occurs, the rotating action between the two hubs becomes loose or sloppy. This can cause hammering between the clutch parts which will reduce the life of the clutch.

KTM recommends inspecting the clutch every 20 bike hours for SX-F models, and every 30 hours for XC, EXC, and XC-W off-road models, and replacing components as necessary. Rekluse has found that these inspection intervals are typically consistent with the expected life of the rubber dampers.

For example: the 450 SX-F (including factory edition) engine operates at high temperatures, and its dampers will require servicing at about 20 hour intervals.

Rekluse recommends inspecting the rubber dampers before installing your new Rekluse clutch product. If your bike has reached or exceeded the recommended inspection interval before installation of this product, perform the clutch installation with **new** rubber dampers. After installation of your Rekluse clutch product, continue to inspect the dampers at these regular intervals and replace if necessary.

The rubber dampers = KTM part #: 78132025100 (6 are required)

5. With the bike in neutral, place your thumbs on the inner hub, at the location of the embossed part numbers, and try to spin the inner hub back and forth inside the outer hub. Rekluse recommends replacing the dampers if you feel slop between the two hubs.



INSTALL THE CLUTCH PACK

NOTICE

When installing the clutch pack, make note of the basket slots. Some OE baskets have “half slots” at the top of the basket tangs. Rekluse products require the entire clutch pack, including the EXP disk, be installed into the MAIN (deeper) basket slots. Do not use the “half slots.”

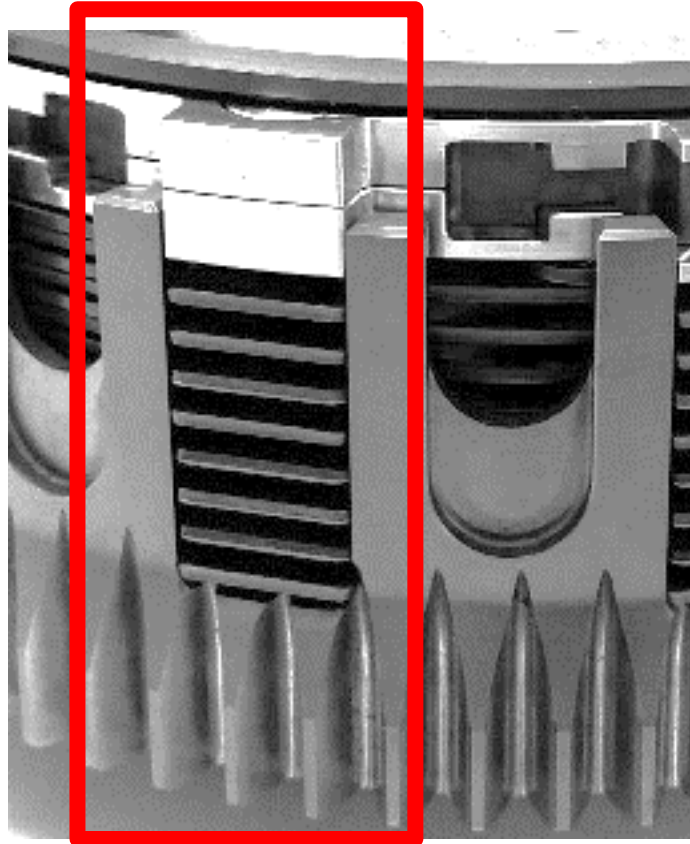

6. Hold a TEC drive plate so that the “shark fin” notches face toward the right. **All the drive plates will follow this orientation.**

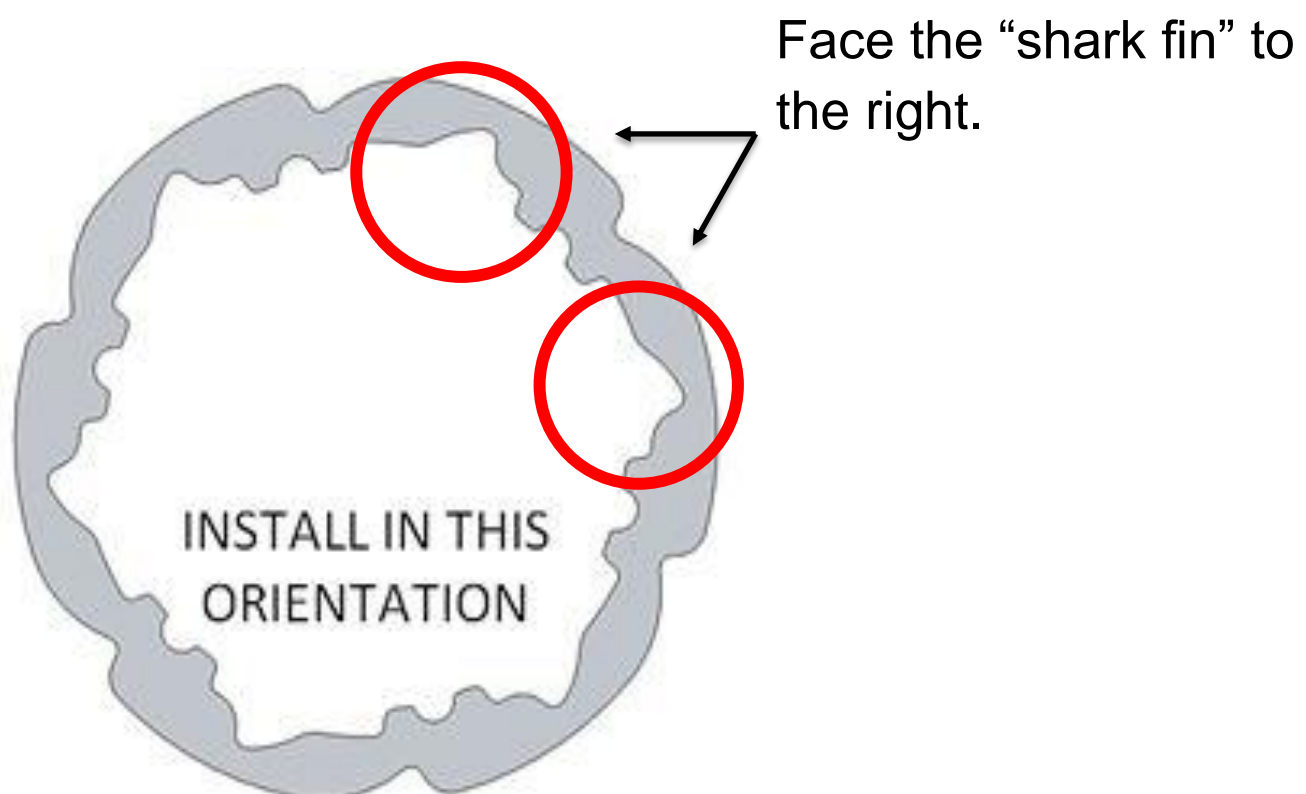

NOTICE

Proper orientation of the drive plates is critical for optimal clutch performance. If you install them backwards the clutch will still function but will lack proper modulation performance.

7. Align the drive pin notches in the TEC drive plate with the drive pins on the hub, then install the drive plate into the basket. Be sure that the drive pins are seated in the notches and not in the bigger sections.

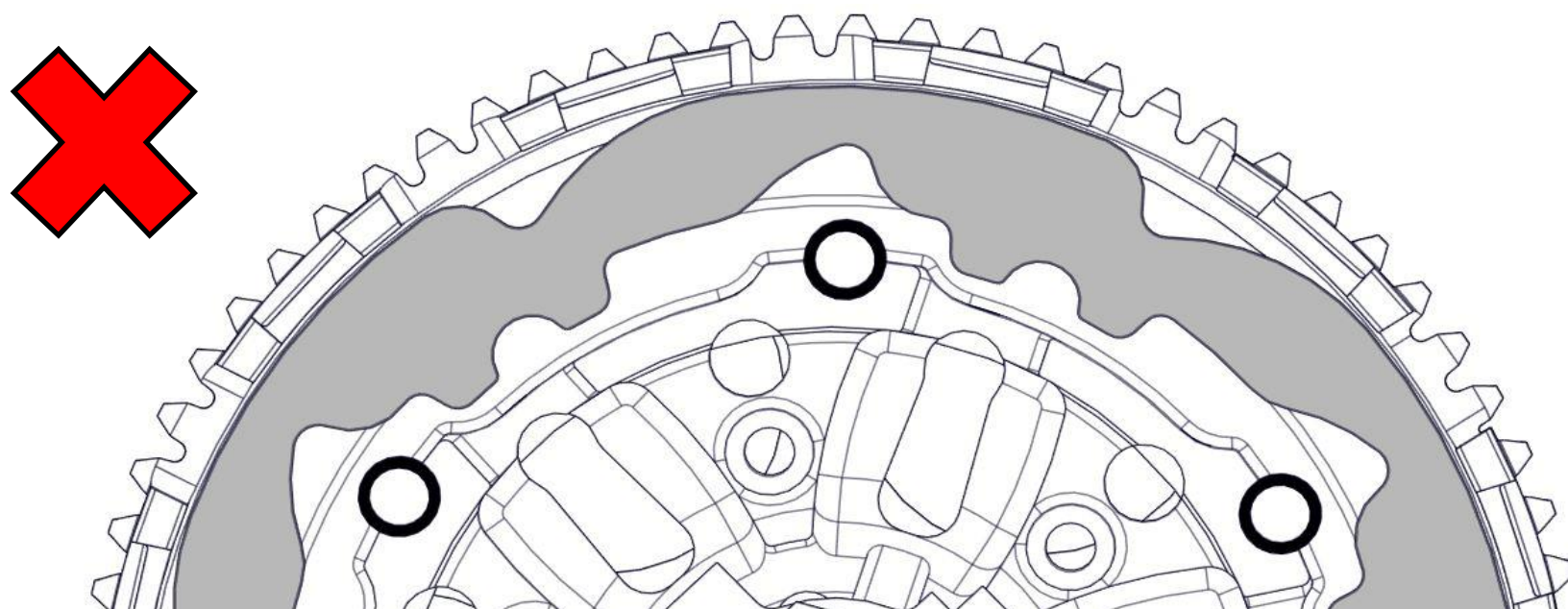
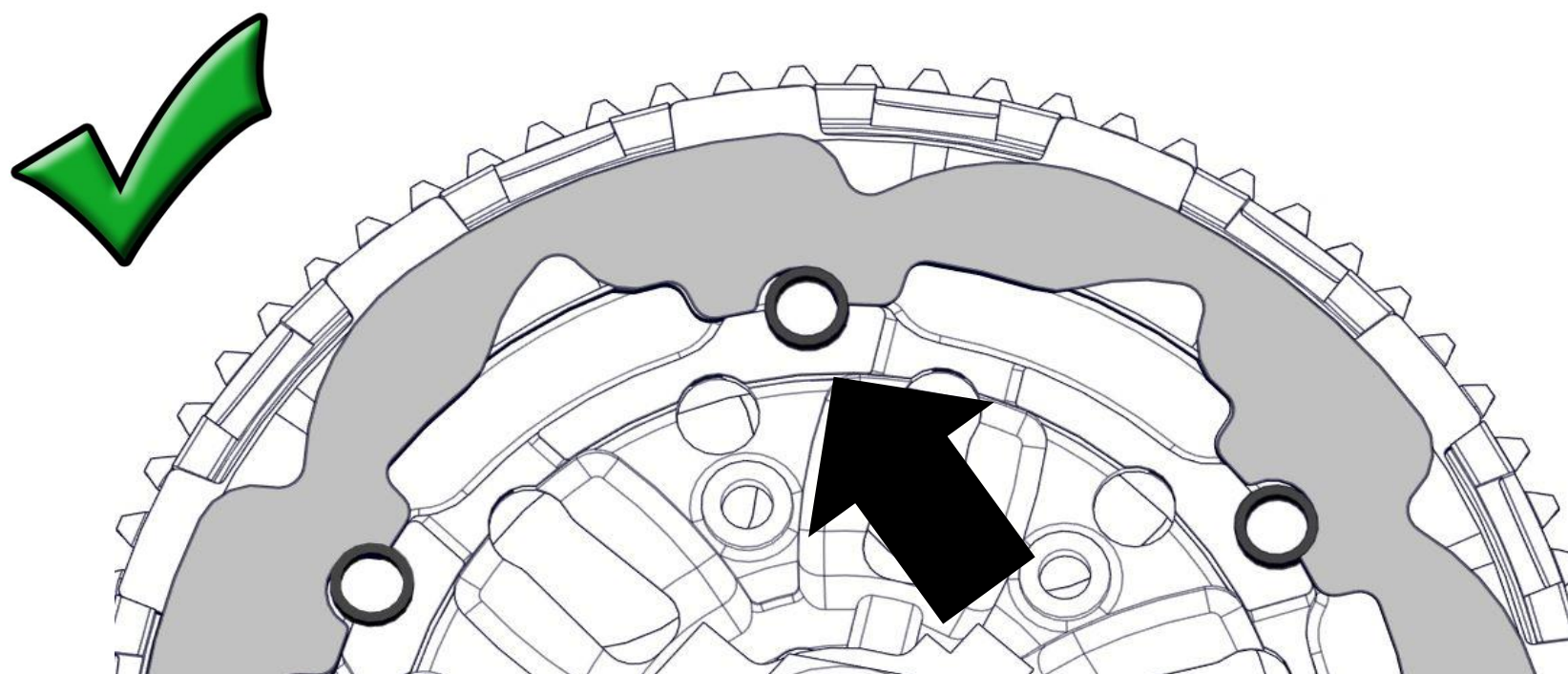

NOTICE

ALL the TEC plates must be aligned in the drive pins notches or damage may occur. The plates will not move when installed correctly.

8. Install a Rekluse friction disk, then continue to alternate steel drive plates and friction disks for the entire clutch pack. *Some friction disks are marked with a small colored dot. This mark is used for processing and can be ignored.*
9. Install the EXP disk on top of the last steel drive plate. Make sure the EXP disk is seated in the main slots along with the clutch pack.

Clutch Pack Configuration

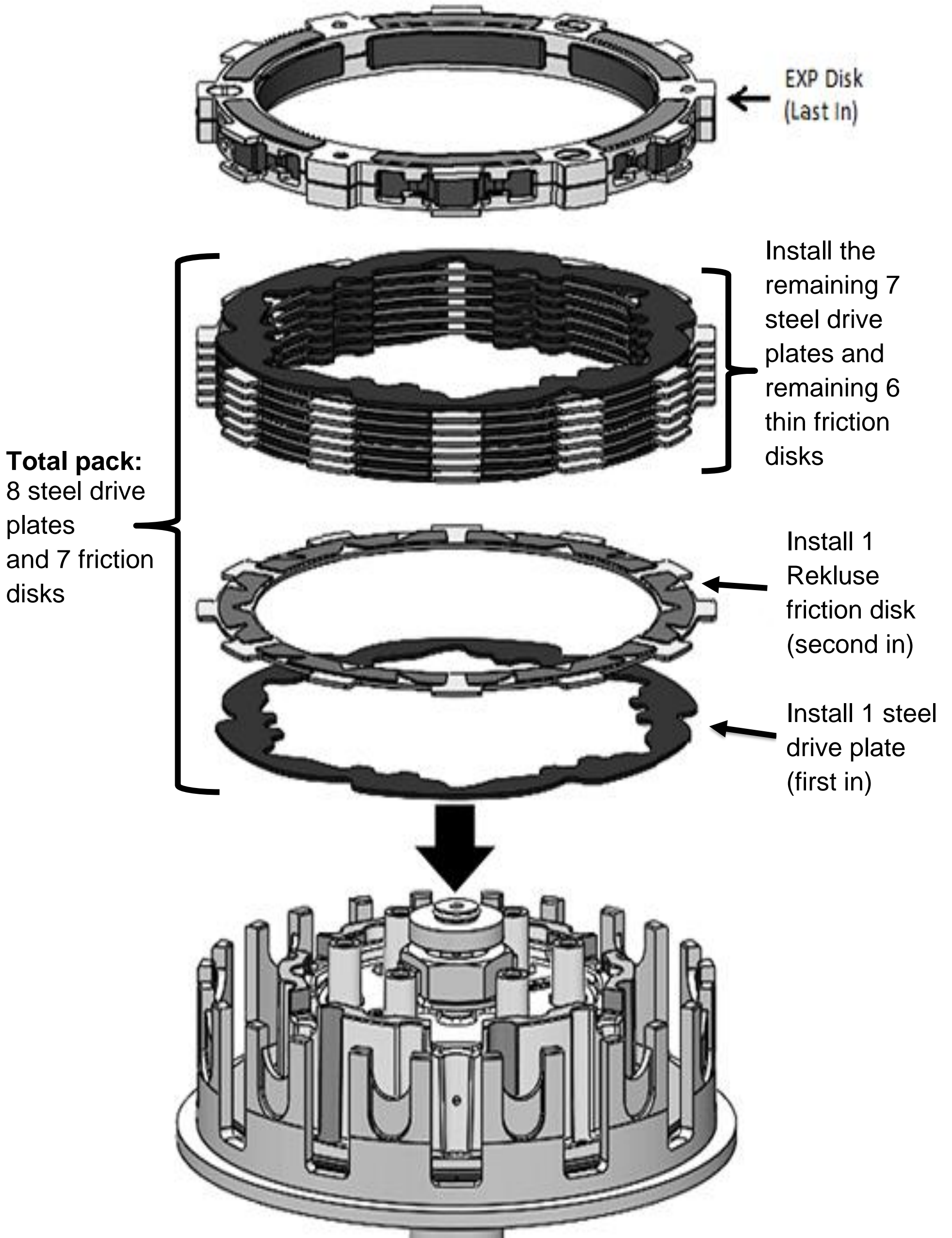

10. Place the Steel Lining Plate onto the Rekluse Pressure Plate. Adding an oil film between them will help them stick together for ease of installation.

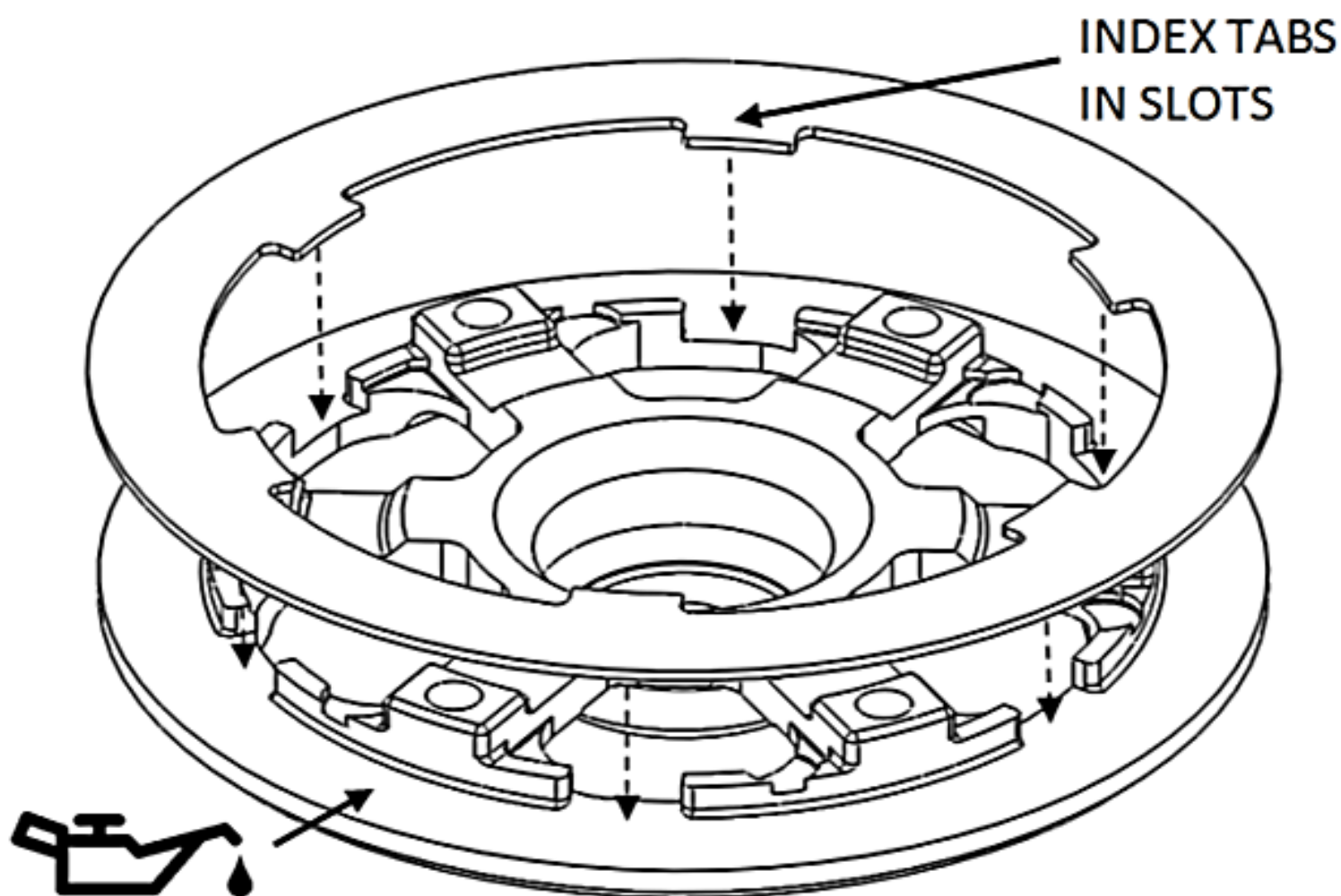

11. Install this pressure plate / lining plate combo, keeping the lining plate against the pressure plate. Hold the pressure plate against the clutch pack until it is bolted down in the later steps.

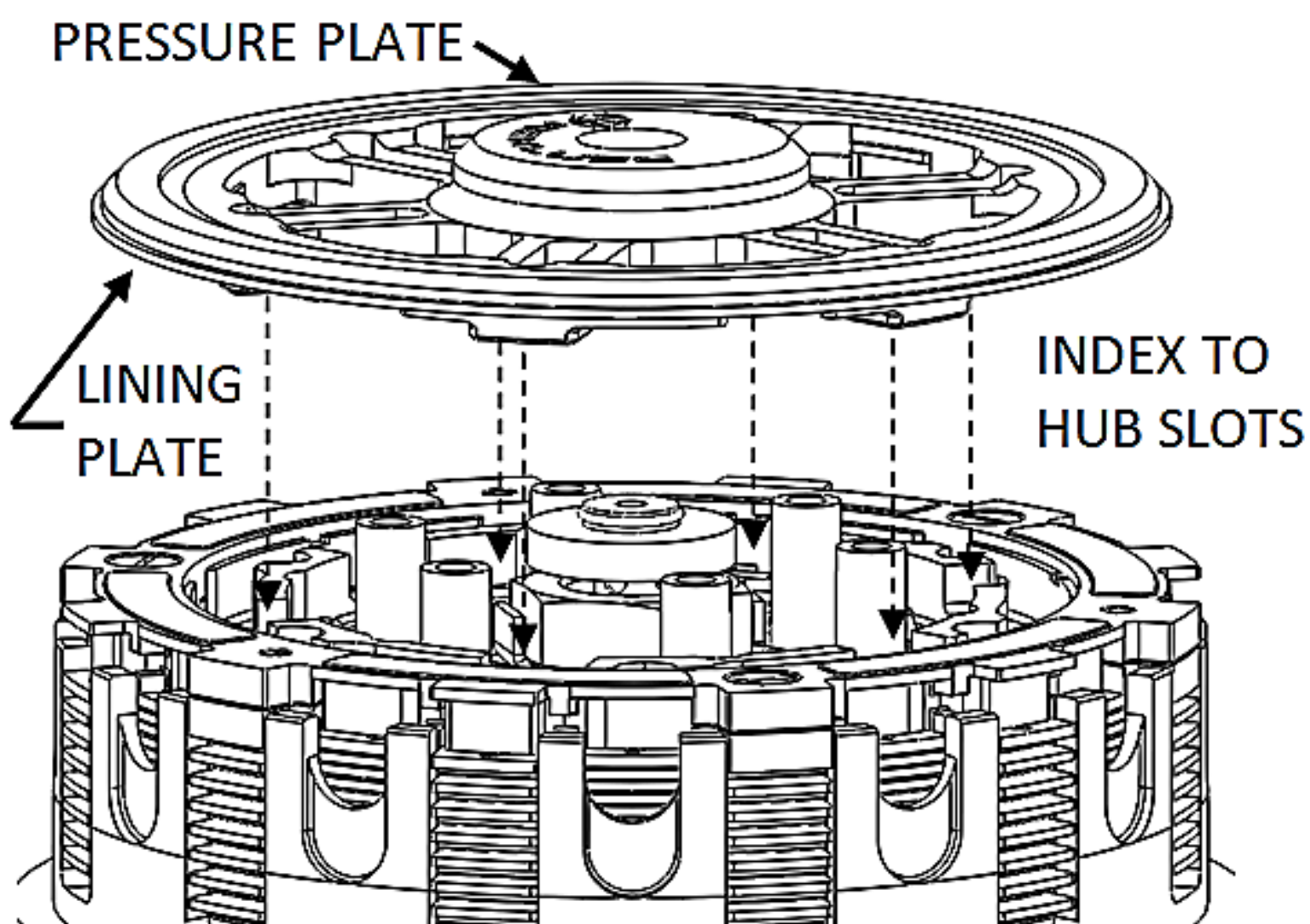

12. Install the pressure ring spacer with the tabs facing up onto the hub posts.

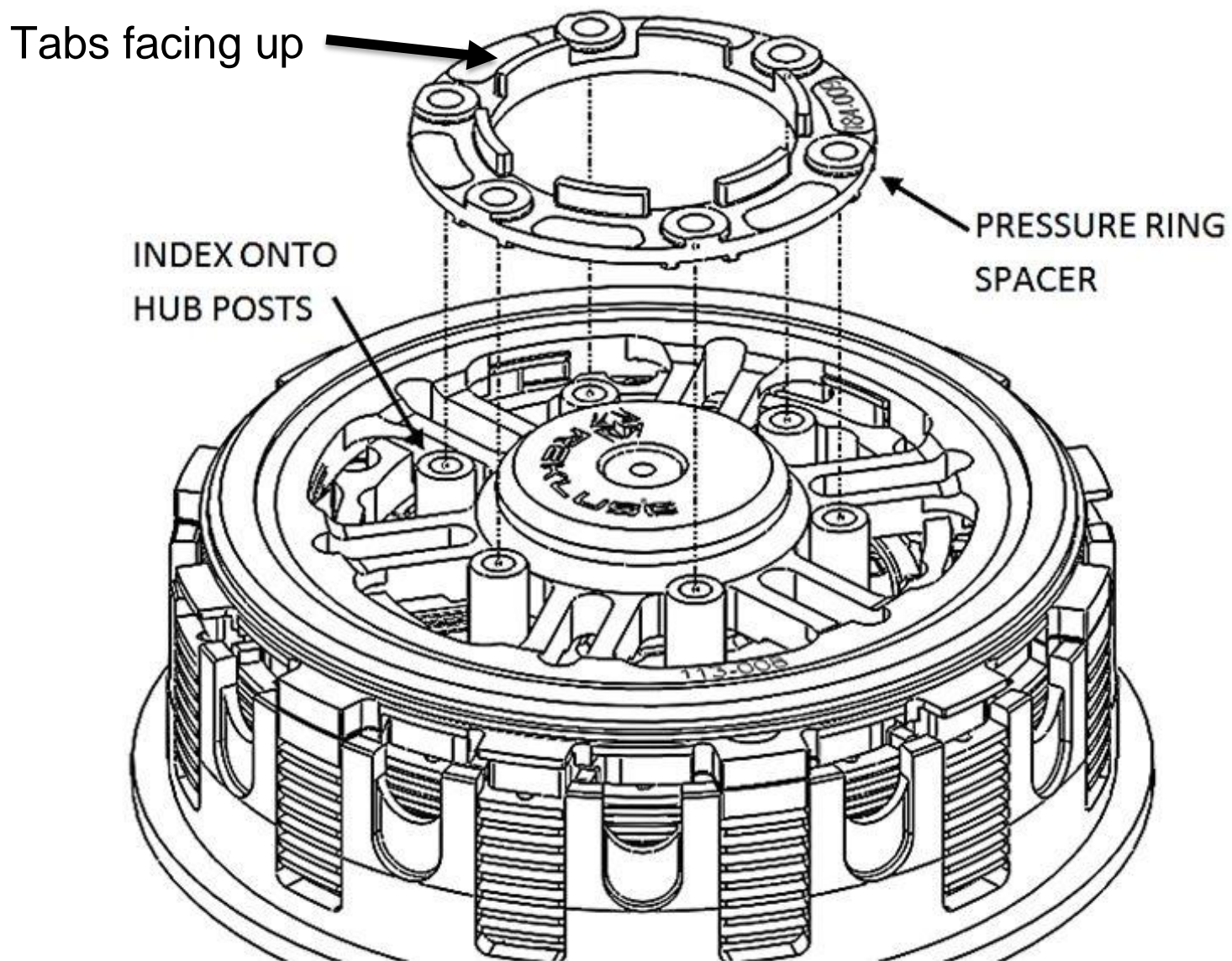

13. Place the OEM slider ring on the pressure plate with the "top" marking facing up. (The top side is rounded and the bottom edge is sharp.)

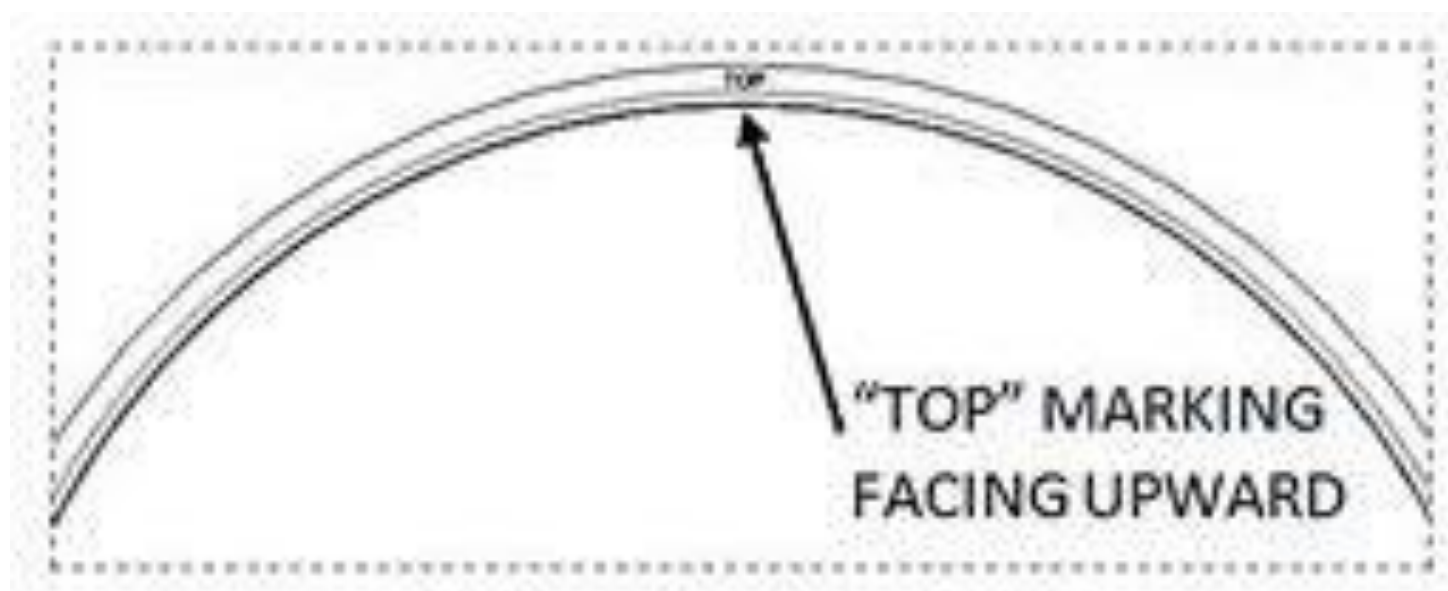

14. Place the OE Belleville spring onto the slider ring, with the rounded dome side facing up.

NOTE: The outer edge of the Belleville spring will make contact with the slider ring. If it does not, the Belleville spring is upside down. See pictures for reference.



Correct – The Belleville spring sits flat against the slider ring.



Incorrect – The Belleville spring is upside down.

15. Install the OEM pressure ring followed by the Rekluse Pressure Plate Screws.

CAUTION: Do not reuse the OEM screws, or clutch cover interference will occur!

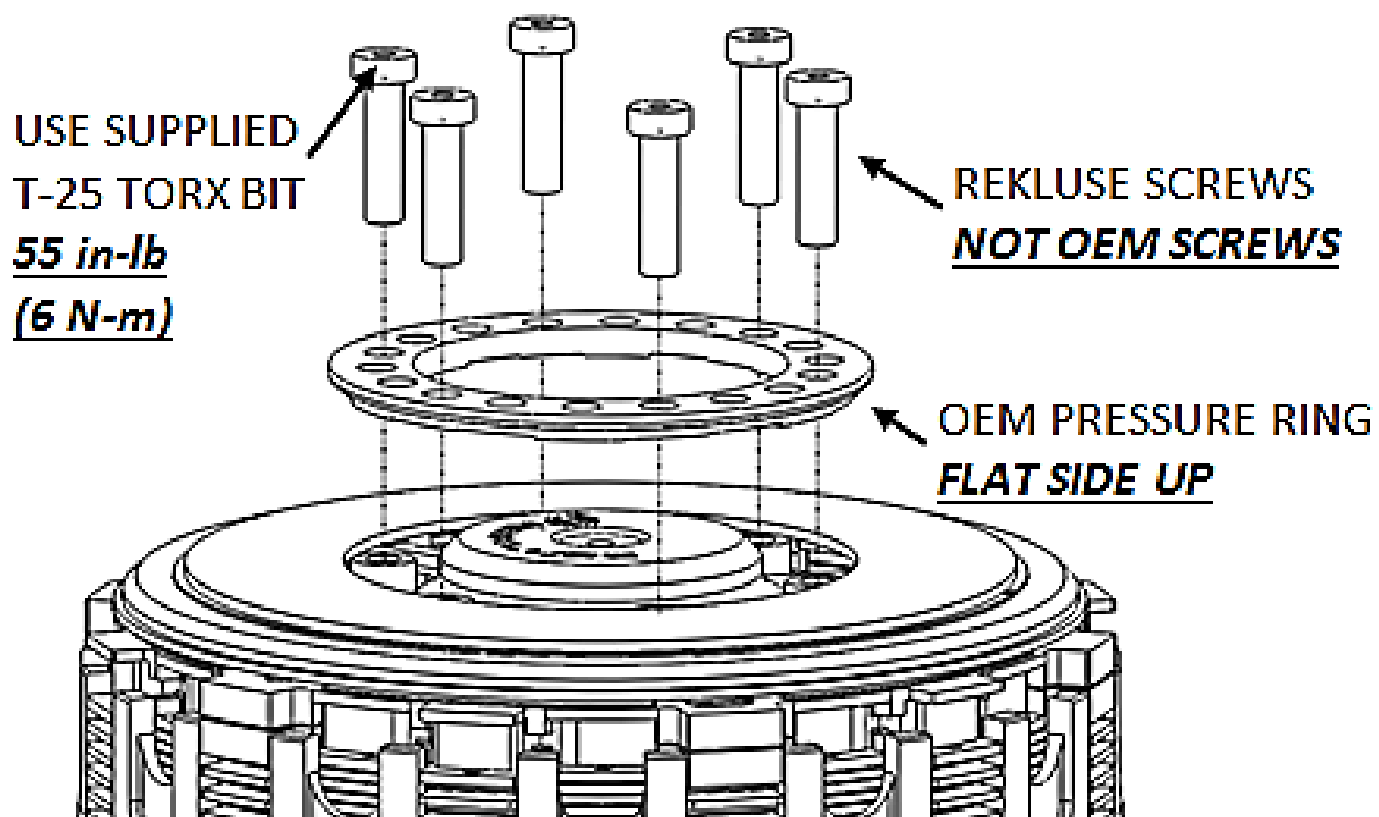

NOTE: There are 3 possible settings on the OEM Pressure Ring. Rekluse recommends setting II for all 4-strokes for optimum performance.

- 16.** Install the OEM clutch cover with Rekluse supplied clutch cover gasket. Apply a thin film of engine oil to both sides of the gasket in order to prevent the gasket from sticking to the case. If your kit did not come with a gasket, reuse your OEM gasket.

⚠ CAUTION

If the Rekluse supplied gasket is not used with the OEM clutch cover, damage will occur to the clutch! Install the included spacing gasket in place of the OEM gasket.



NOTICE

The cover spacing gasket is only included in certain kits. If your kit did not include a Rekluse gasket, reuse your OEM gasket.

NOTE: If installing a Rekluse clutch cover, the spacing gasket is not needed.

- 17.** Install the clutch cover bolts in their proper OEM location. Lightly tighten the cover bolts in a star pattern. Torque the bolts in small increments before tightening all the bolts. Torque the cover bolts to OEM specification – **7.4 ft-lb (10 N-m)**.

WARNING:

Failure to install the OEM clutch cover bolts back in their proper location can result in damage to your motorcycle. Be sure to torque the bolts in a star pattern. The clutch cover will crack or break if too much torque is applied at once or if bolts are tightened in a different pattern.

SLAVE CYLINDER INSTALLATION

Handle with care! During assembly there is a small ball bearing installed in the slave piston with a small amount of grease. When installing the Rekluse slave cylinder, make sure the ball does not come loose.

18. On a workbench (away from the engine), bleed the Rekluse slave cylinder by this procedure:

a. Use a 4mm Allen key to make the top O-Ring visible on the adjuster screw.

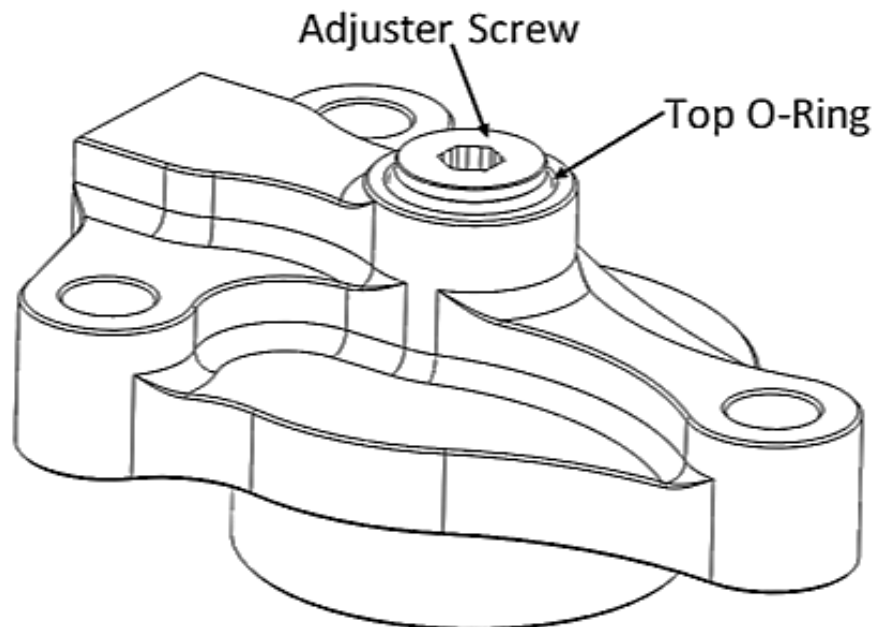

b. Compress the piston until it bottoms.

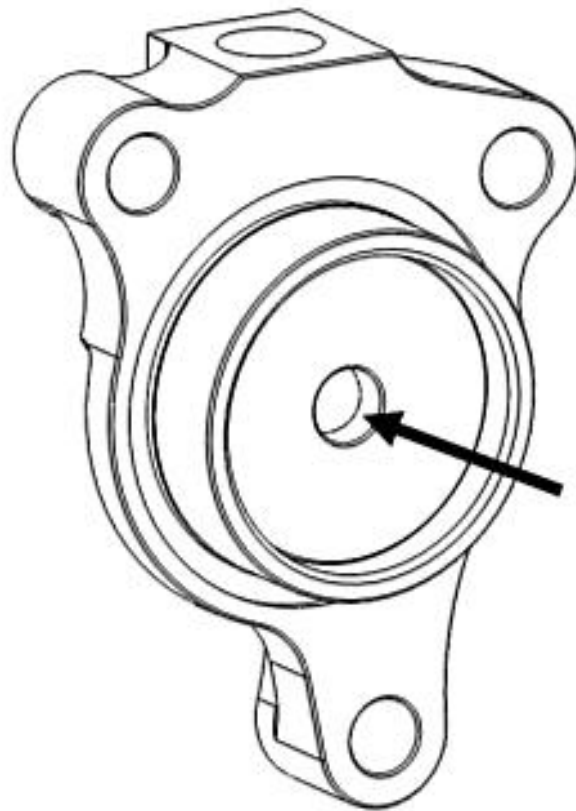

c. Pour clutch fluid into the slave cylinder port.

NOTICE

Be sure to use the correct clutch fluid! Check the cap of the clutch master cylinder to determine which clutch fluid to use. Failure to use the correct fluid will result in seal damage and/or failure.

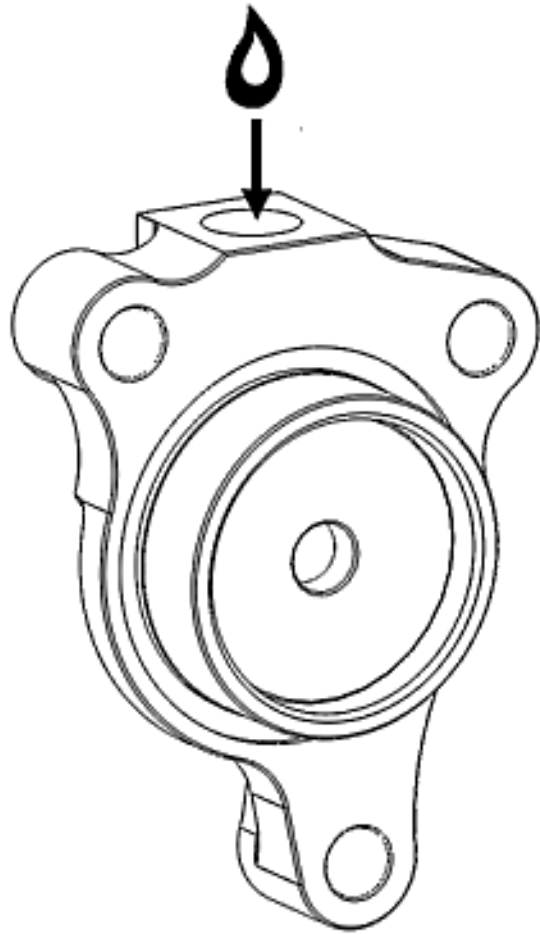

d. Turn the adjuster screw clockwise until it bottoms, keeping the fluid topped off.

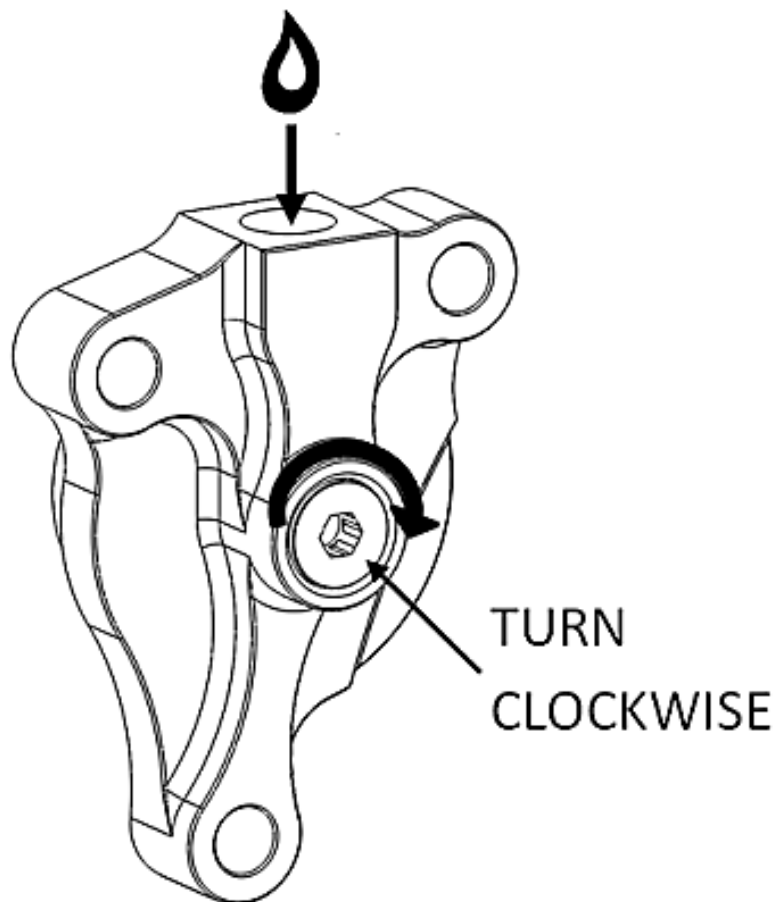

e. Turn the adjuster screw back to the initial position with the top O-ring visible.

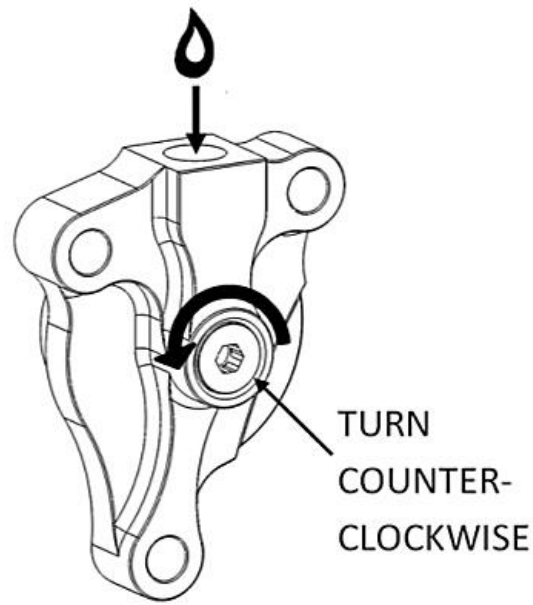

f. Compress the piston until it bottoms out. Repeat the process until there is no longer air escaping from the top port when the piston is compressed.

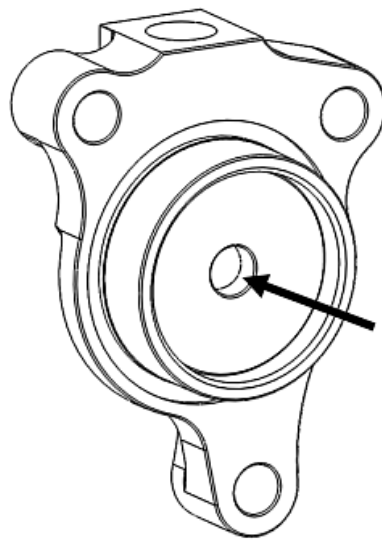

NOTICE

When compressing the piston, fluid can shoot out from the slave cylinder port. Be sure to wear eye protection.

g. Check that the ball bearing is still in place.

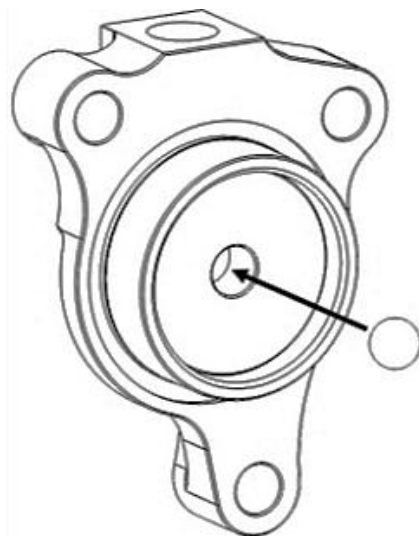

19. Stand the bike up and lean it on its kickstand or place it on a suitable bike stand.

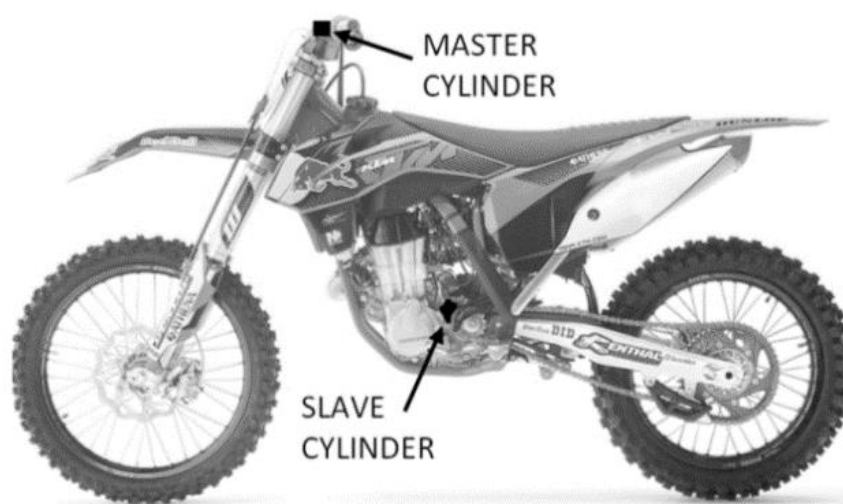

NOTE: Some slave cylinders have an 8mm banjo bleeder bolt, a 10mm banjo bleeder bolt, or a straight fluid line. Follow the instructions based on the type of fluid line on your bike.

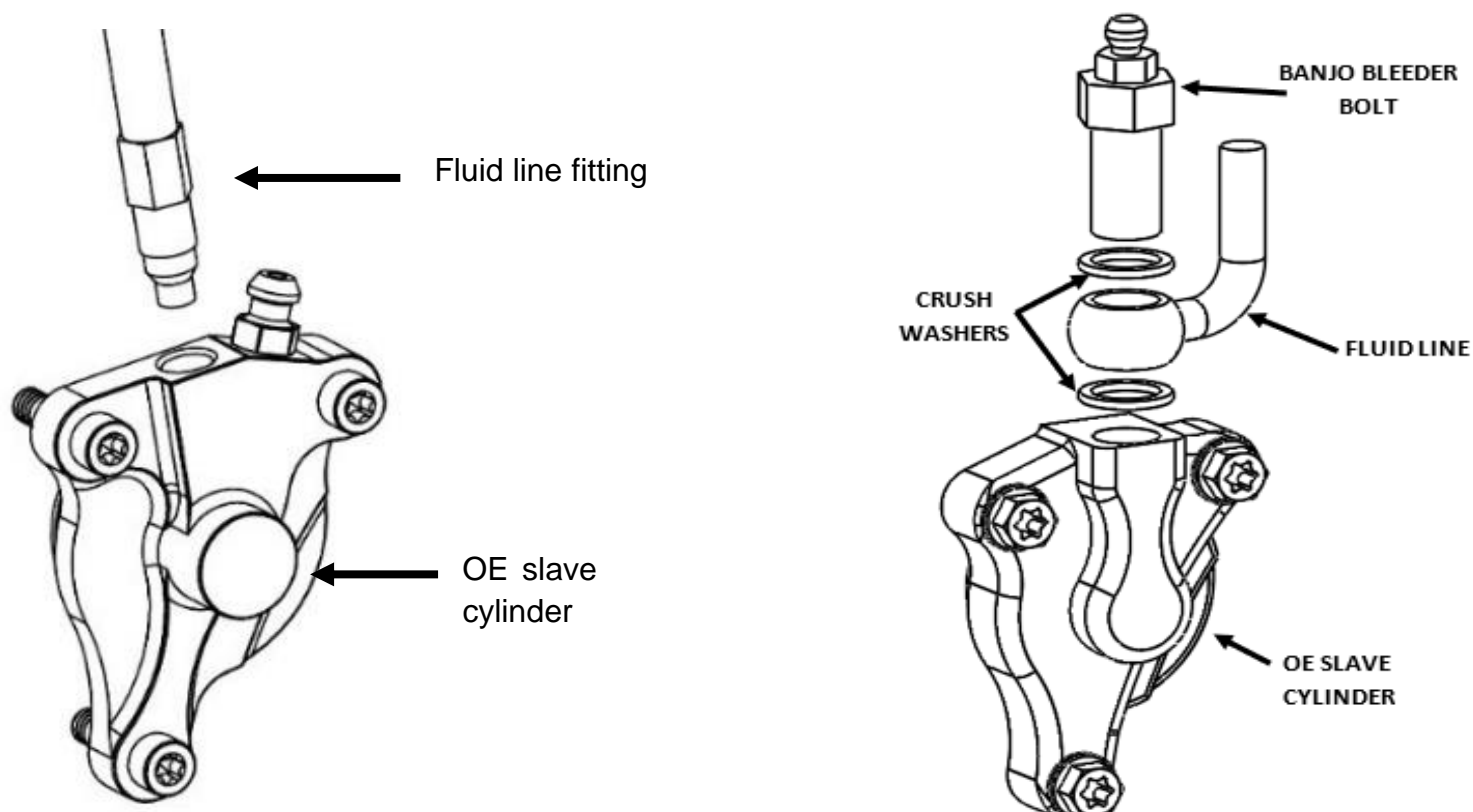

20. On the left side of the bike, while leaving the OE slave cylinder bolted on the engine, use a wrench to remove the banjo bleeder bolt or fluid line from the OE slave cylinder.

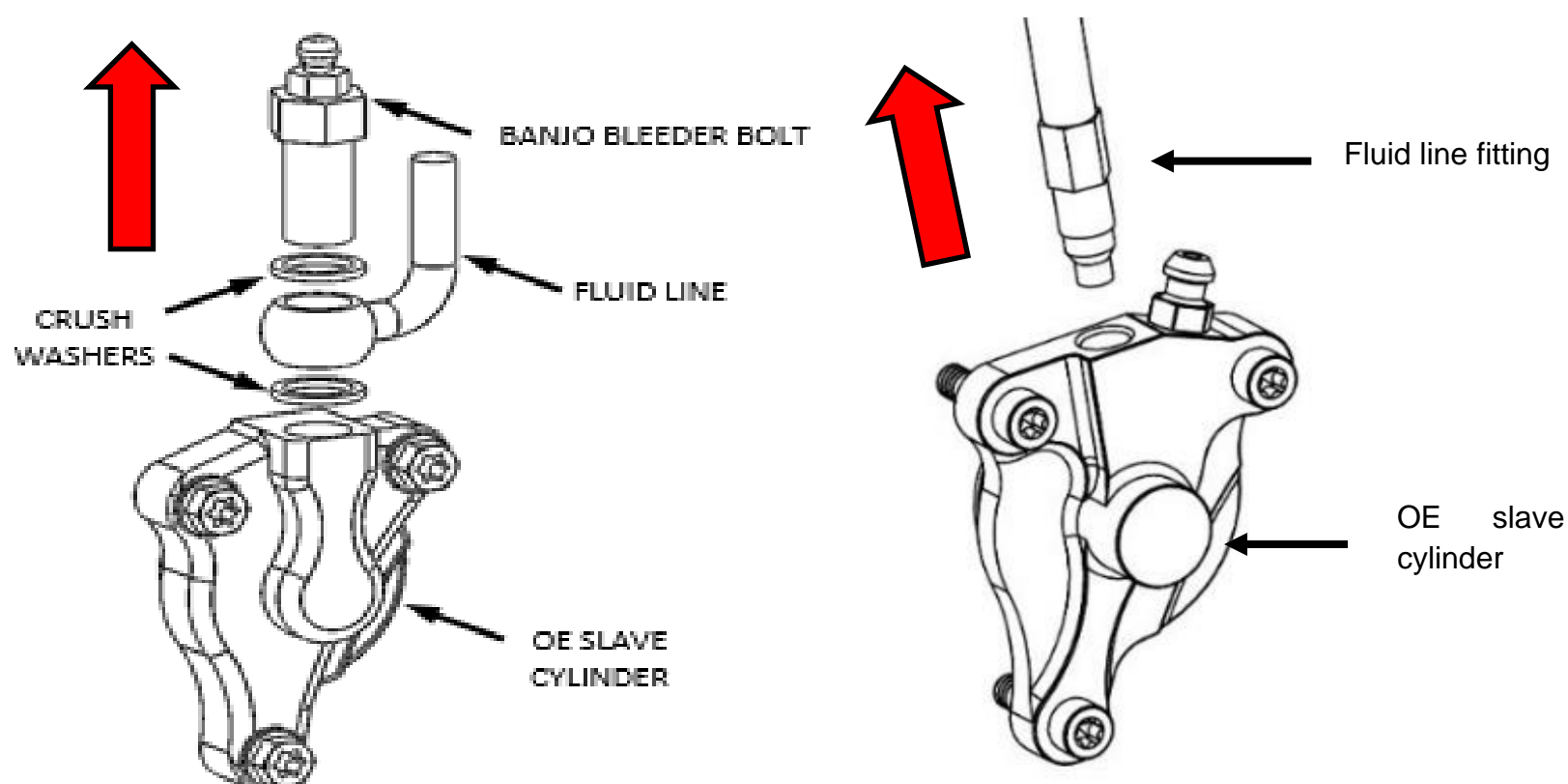

21. Install clutch fluid line onto Rekluse Slave Cylinder

8mm Banjo Bleeder Bolt:

- a. Your Rekluse slave cylinder only has a single port and no bleed port. Attach the clutch fluid line to the Rekluse slave cylinder using the OE banjo bleeder bolt and the 2 new crush washers from Rekluse. Make sure the clutch fluid line is between the 2 crush washers.

10mm Banjo Bleeder Bolt:

- b. Your Rekluse slave cylinder comes with a banjo bolt and a preinstalled bleeder bolt. Set the OE banjo bleeder bolt and crush washers aside. They will not be reused. Attach the clutch fluid line to the Rekluse slave cylinder using the supplied banjo bolt and the 2 new crush washers from Rekluse. Make sure the clutch fluid line is between the 2 crush washers.

Straight Fluid Line:

- c. Attach the clutch fluid line directly to the Rekluse slave cylinder. You will not use the crush washers.

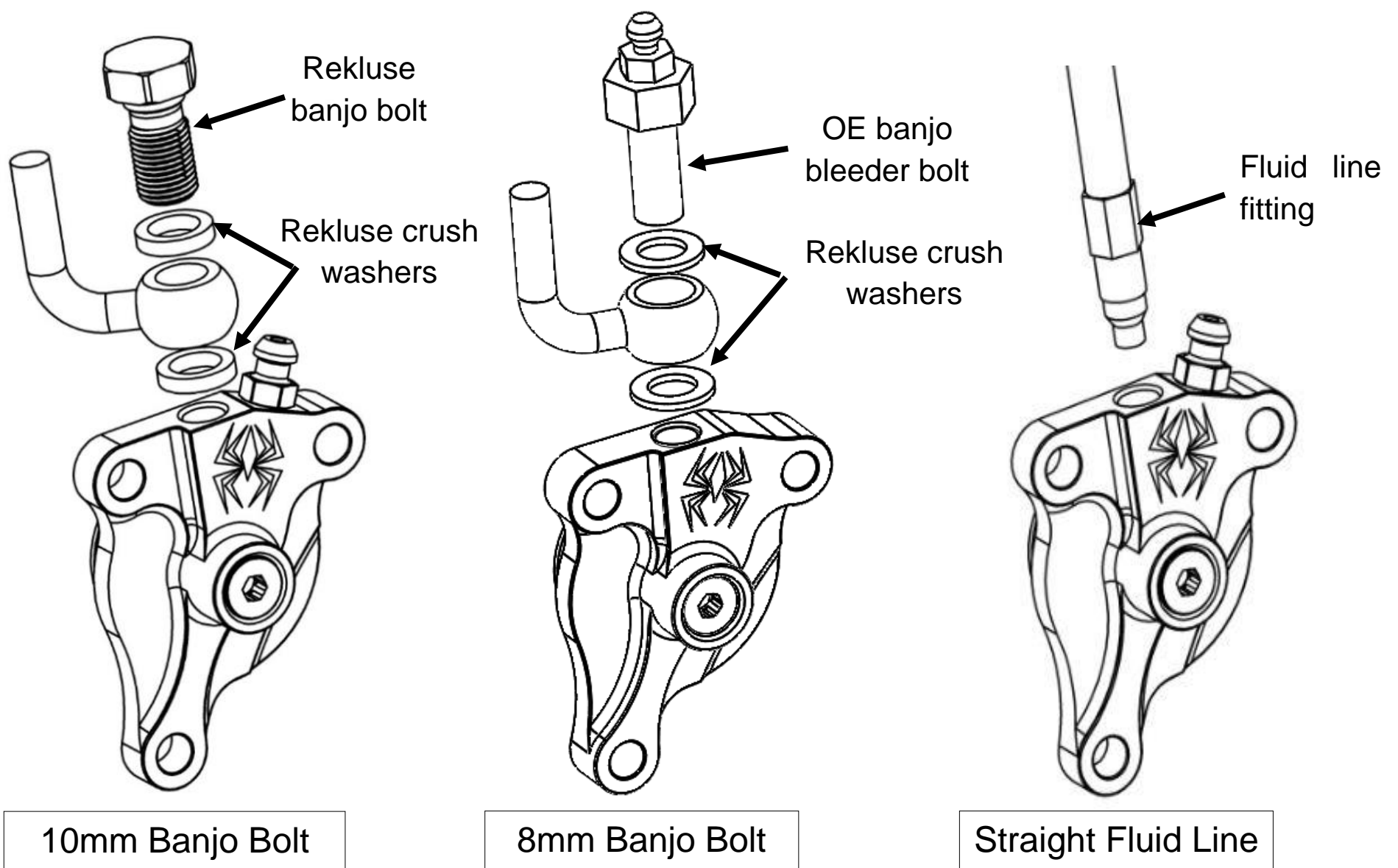

NOTE: A quick transfer of the fluid line will result in less bleeding in the following steps.

22. Tighten the banjo bolt (or fluid line fitting) with your hand until snug. (You will torque it to spec once installed on the bike.)

23. Remove the cap and bladder from the clutch master cylinder.

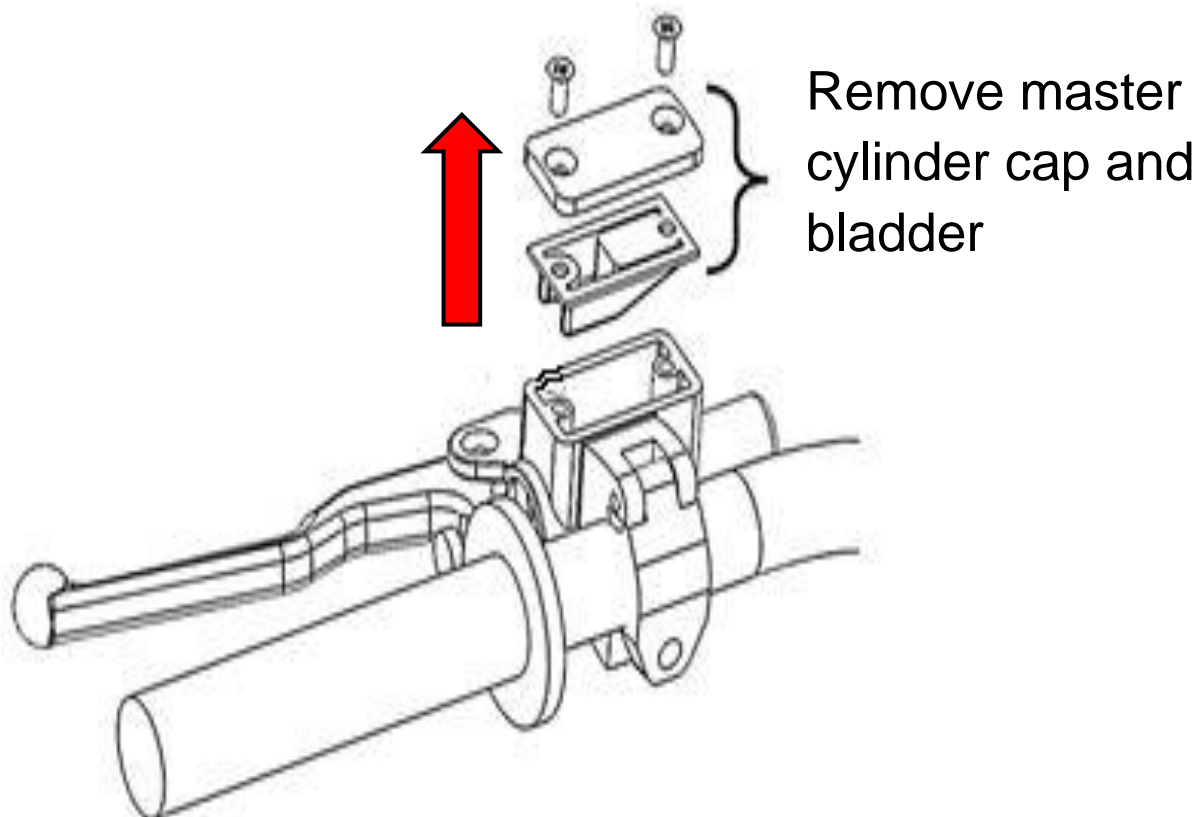

24. With the clutch fluid line attached to the Rekluse slave cylinder, remove the OEM slave cylinder from the engine. Keep the OEM bolts for reuse.

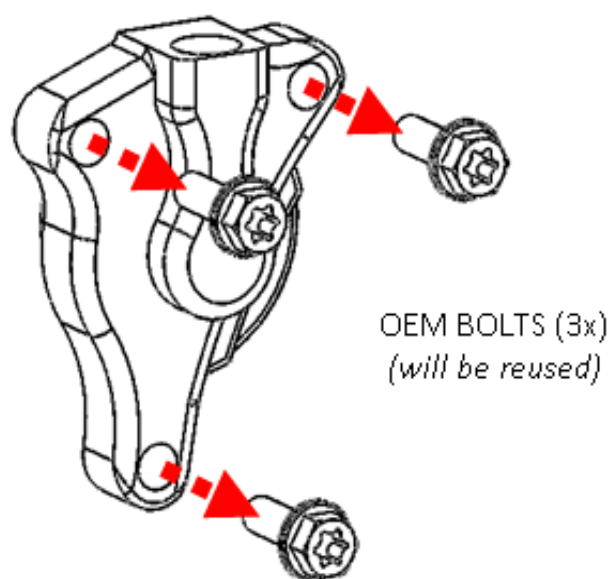

25. Mount the Rekluse slave cylinder to the engine using the OEM bolts.

NOTE: Some models have a piston diaphragm seal. DO NOT REUSE them if OEM equipped.

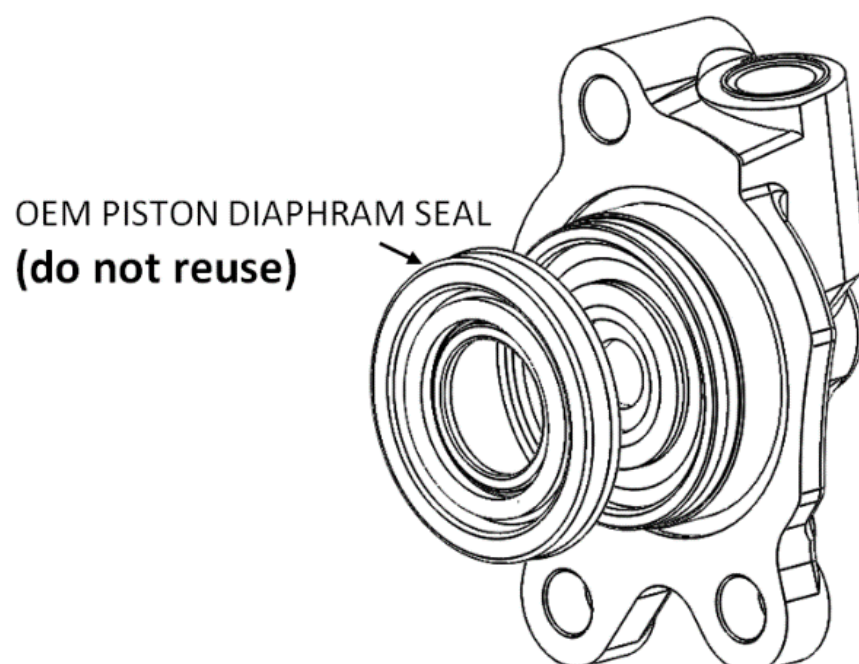

NOTE: When installing case sealing O-ring seal (OEM or Rekluse supplied) ensure it is seated against slave cylinder flange.

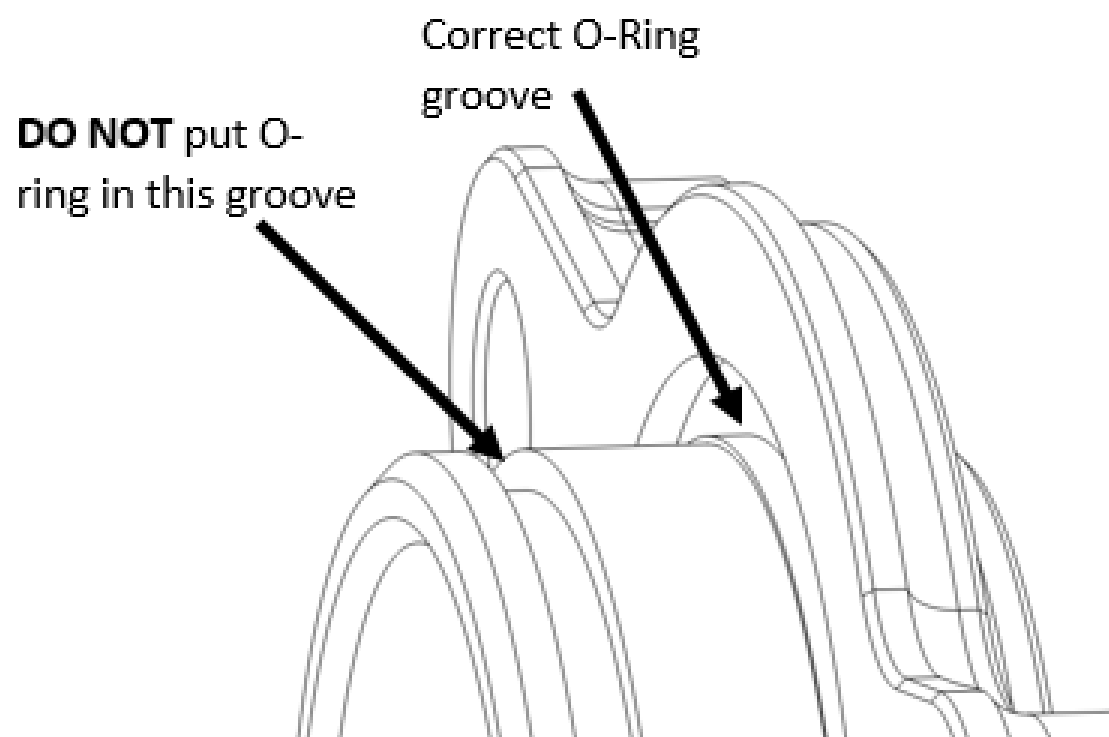

NOTE: The Rekluse slave cylinder comes preassembled in the kit. If the parts become separated, assemble them in the following order: Rekluse slave cylinder, O-ring, then the supplied paper gasket.

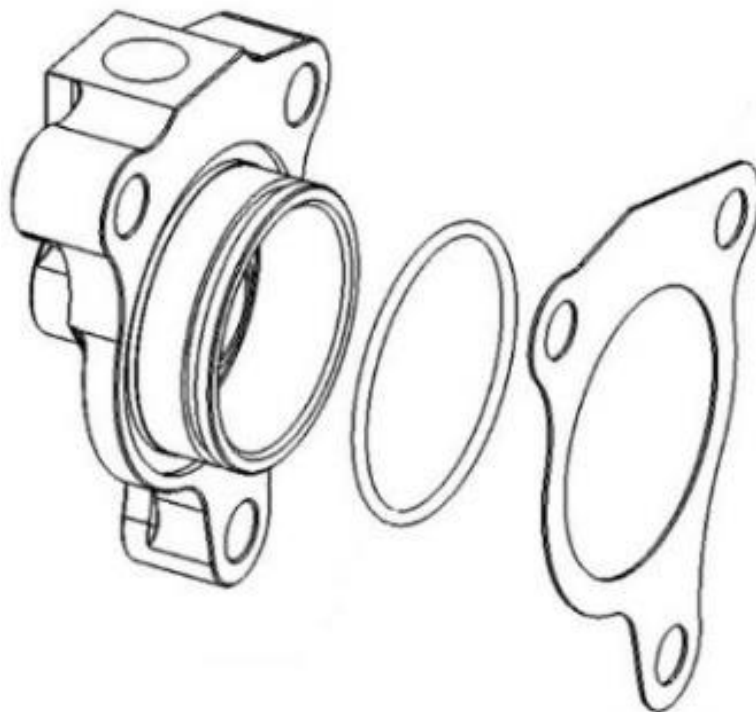

26. Torque the banjo bolt to 18 ft-lb (25 N-m) per OEM specification.

27. Optional: If you purchased the Rekluse Slave Guard accessory, install it now. using the instructions in the kit.



28. Attach the supplied bleed tube to the banjo bolt port and loop it into a suitable catch bottle.

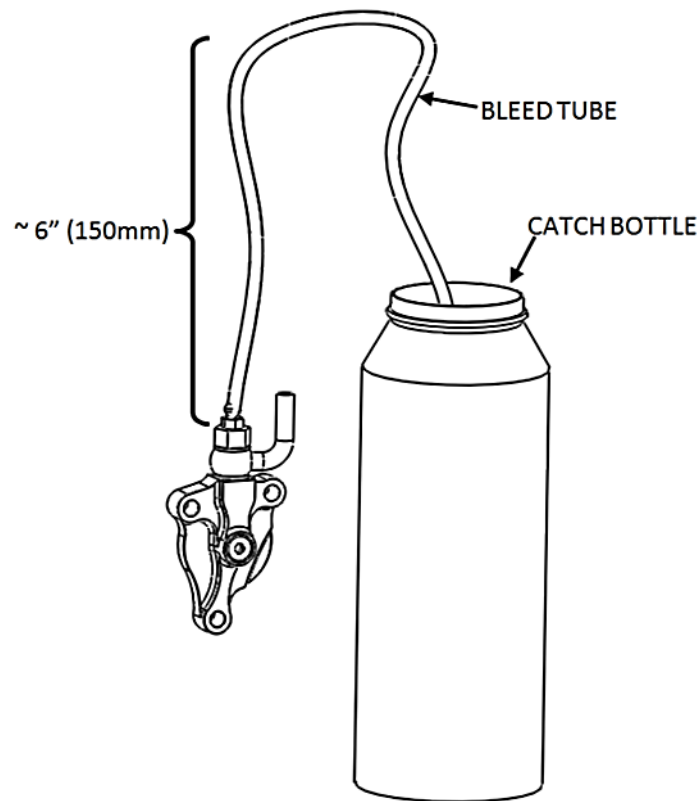

29. Pump the clutch lever 3-5 times then hold it against the bar/grip.

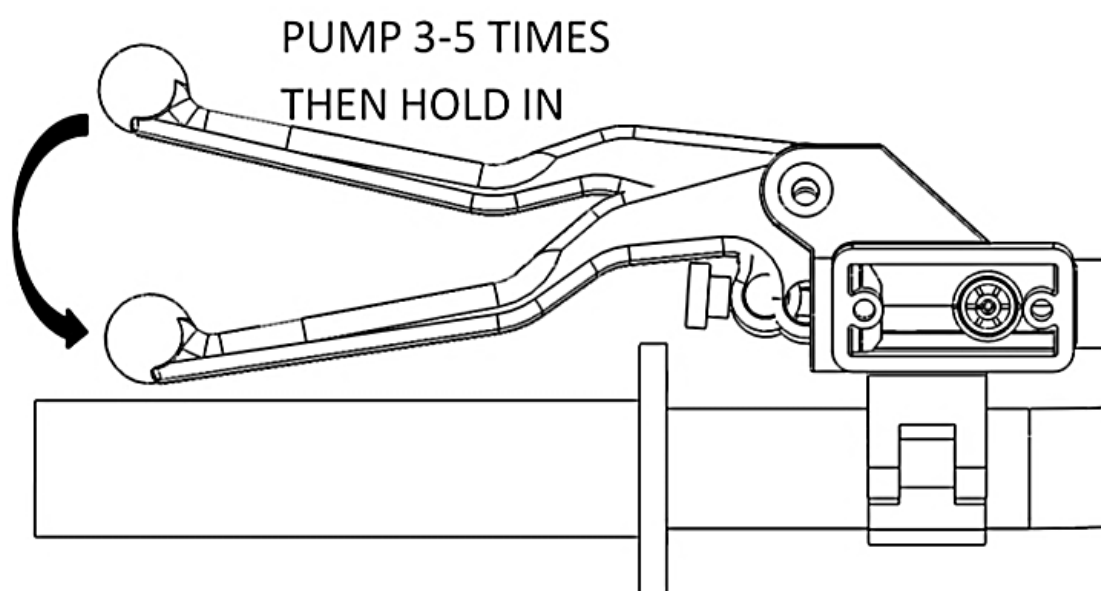

30. Using an 8mm wrench, open the bleed port. Air and fluid should come out of the bleed tube. Tighten the bleed port.

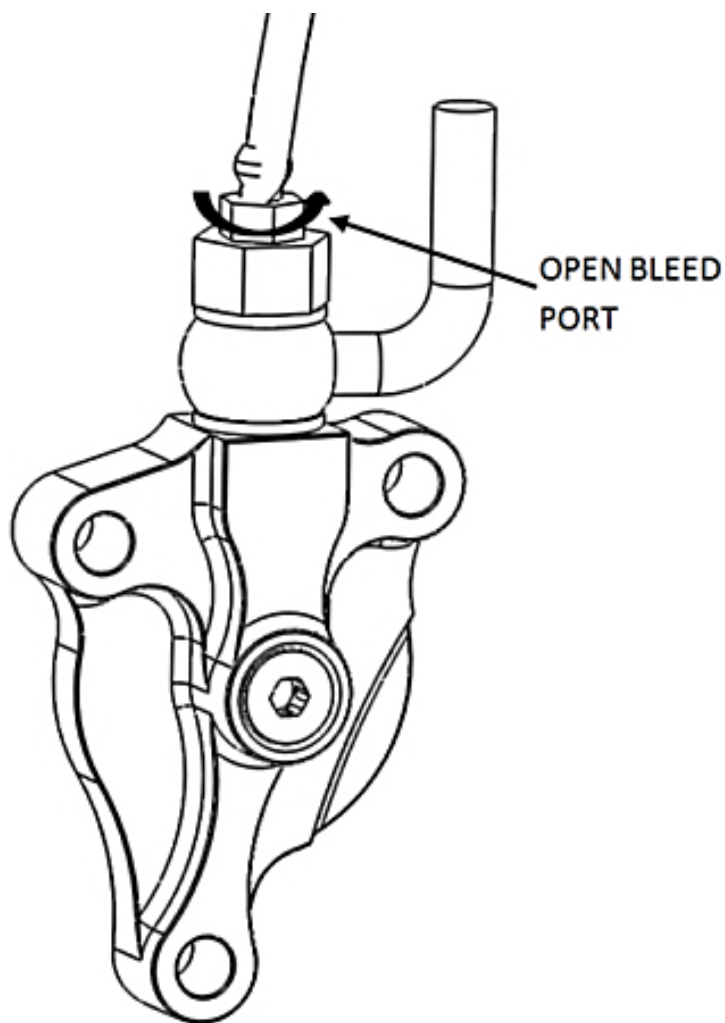

31. Slowly release the clutch lever and check the fluid level in the clutch master cylinder.

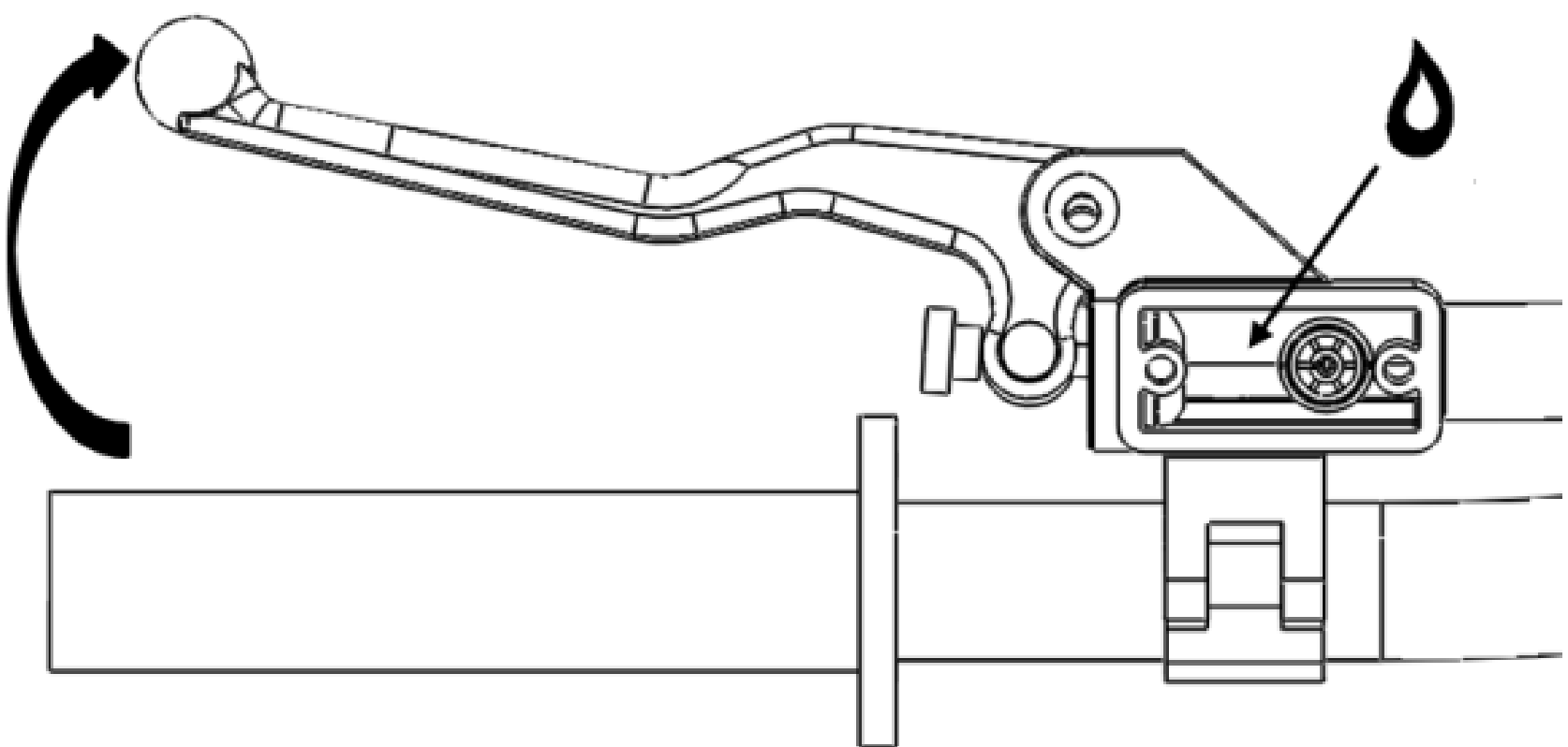

32. Repeat the previous 3 bleeding steps until air no longer comes out of the bleed port. Then, check that the clutch lever functions properly. Repeat the bleeding procedure if necessary.

33. Check that the clutch master cylinder is 75% full, then replace the cap and bladder on the clutch master cylinder.

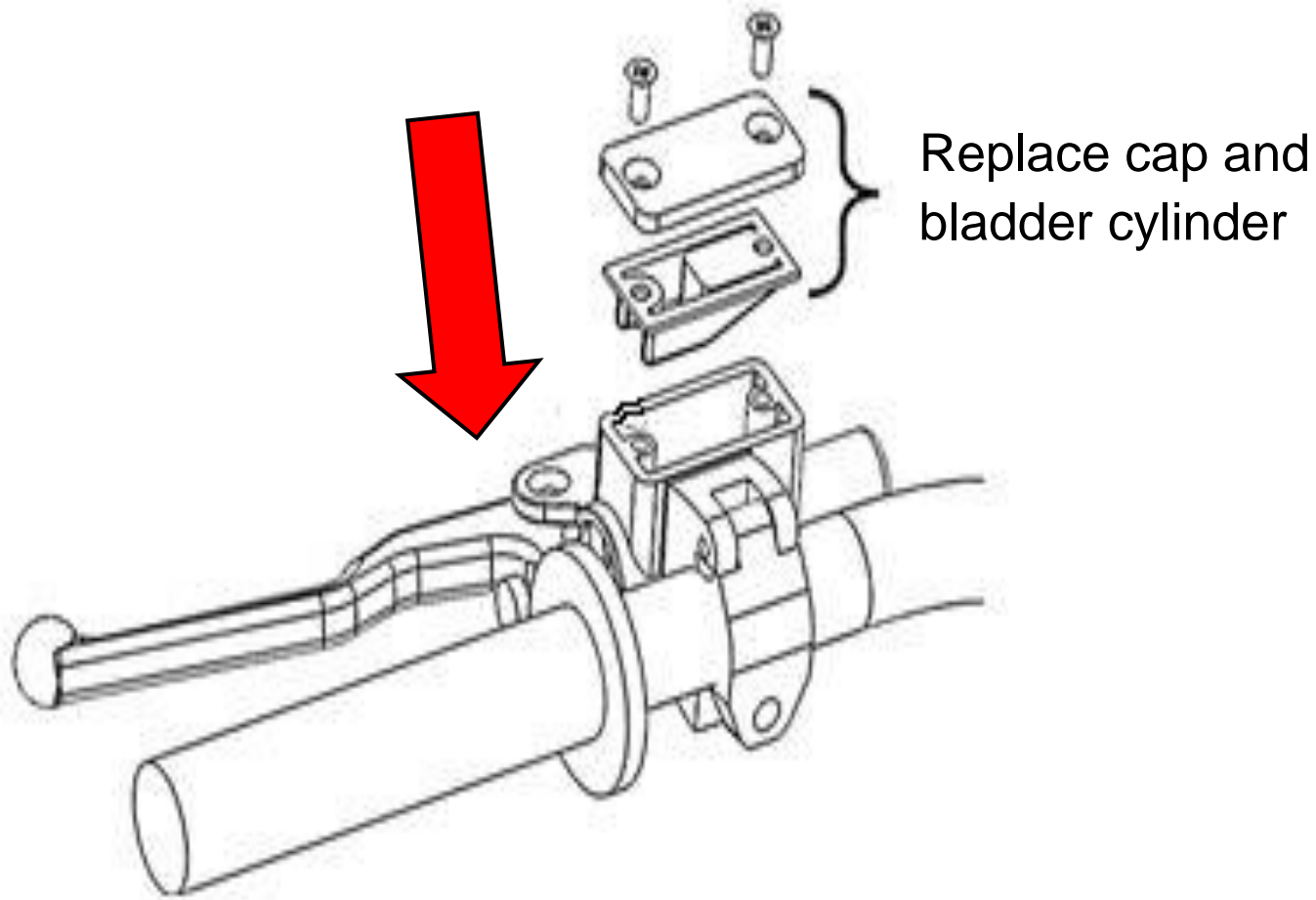

34. Remove the bleed tube and bottle, then torque the bleed screw to 150 in-lb (17 Nm).

35. Finally, replace the rubber dust cap over the bleeder screw.

SETTING THE INSTALLED GAP

DEFINITION: “Installed Gap” is the separation in the clutch pack created by the adjustment of the Adjuster Screw in the Slave Cylinder. This gap is what allows the clutch to spin freely until the desired RPM is reached for engagement; it must be set correctly for optimal performance.

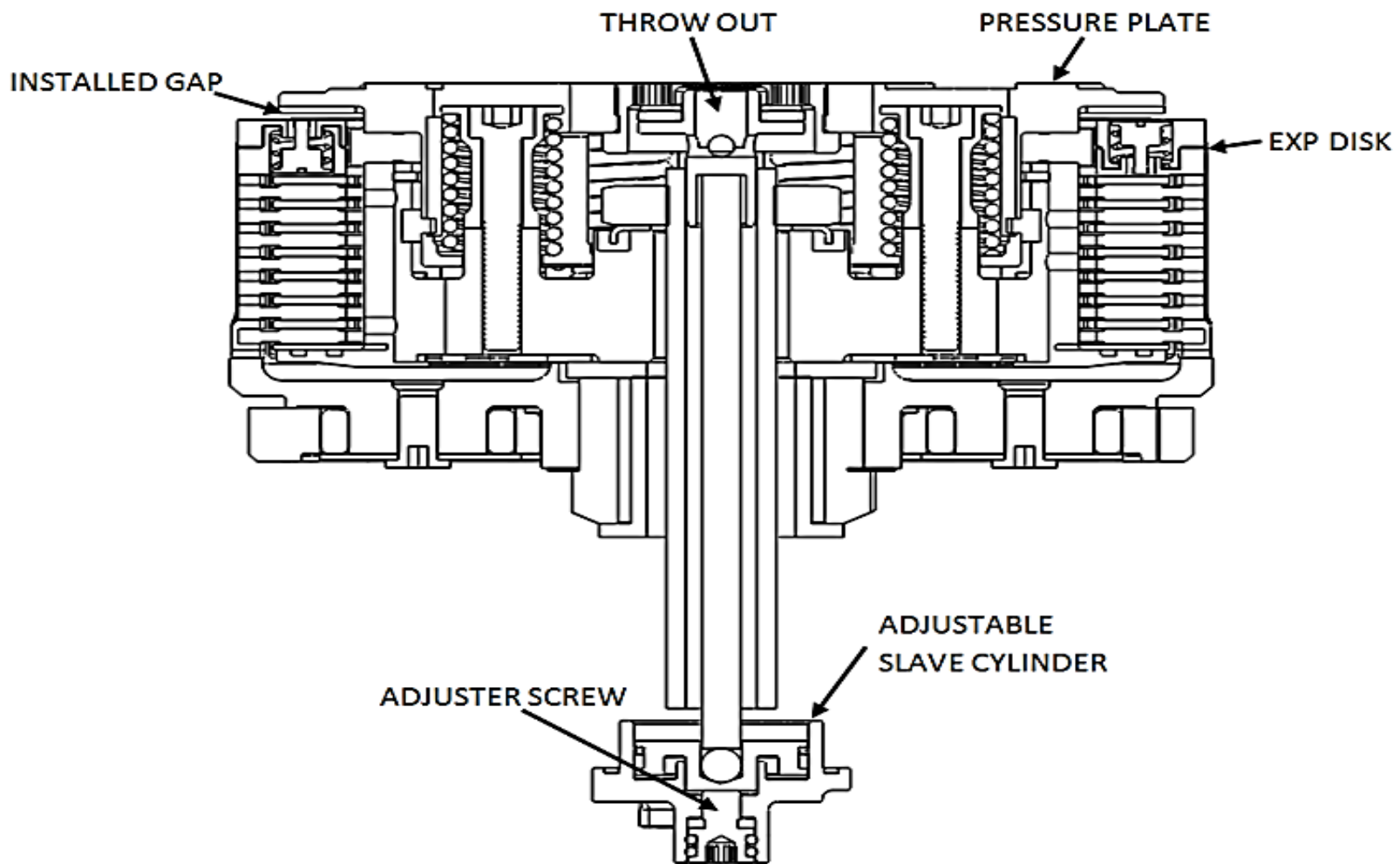

1. Using the long end of a 4mm Allen key, turn the adjuster screw clockwise until it stops under moderate pressure. You are trying to feel for the point at which the throwout will start to lift the pressure plate. This is the “starting point”.

NOTICE

It may take a few tries to find the point at which the system is bottomed out. You should feel a distinguishable change in turning effort at this point.

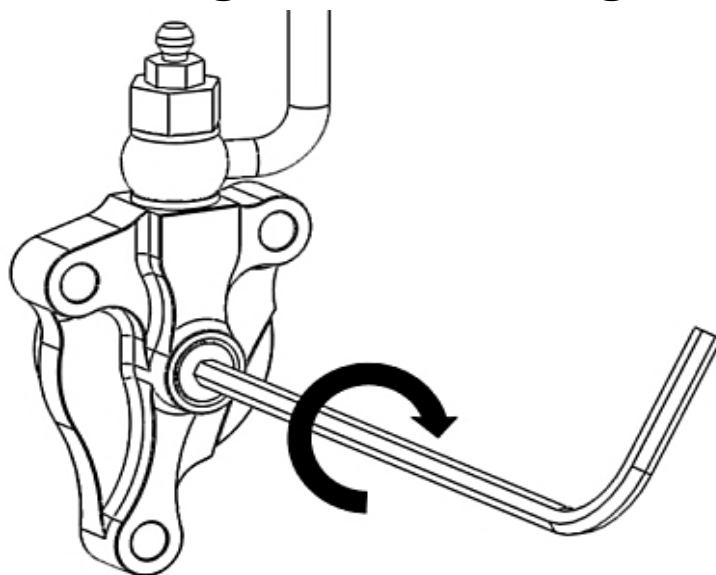

2. Once you have found the starting point, turn the adjuster clockwise 1 full turn plus 5 marks (or “1+5”). **This is NOT your final setting**, but it is a good reference point for using Free Play Gain to find the correct setting.

CHECKING FREE PLAY GAIN

⚠ WARNING

Always make sure that the bike is in NEUTRAL before checking Free Play Gain. Failure to do so may result in the bike lurching forward, and loss of control and/or injury may result.

NOTICE

Before performing this step, please visit our website at rekluse.com/support to view the TECH VIDEO entitled “How to Check Free Play Gain”.

“**Lever Free Play**” is essentially the “slack” in the clutch lever before it starts actuating the clutch. Applying a light finger pressure will take up this slack.



“**Free Play Gain**” is the increase of lever free play as the auto-clutch engages. This happens when the RPM increase from idle through around 5000 RPM. Free Play Gain is caused by the expansion of the EXP disk which lifts the pressure plate away from the throwout assembly.

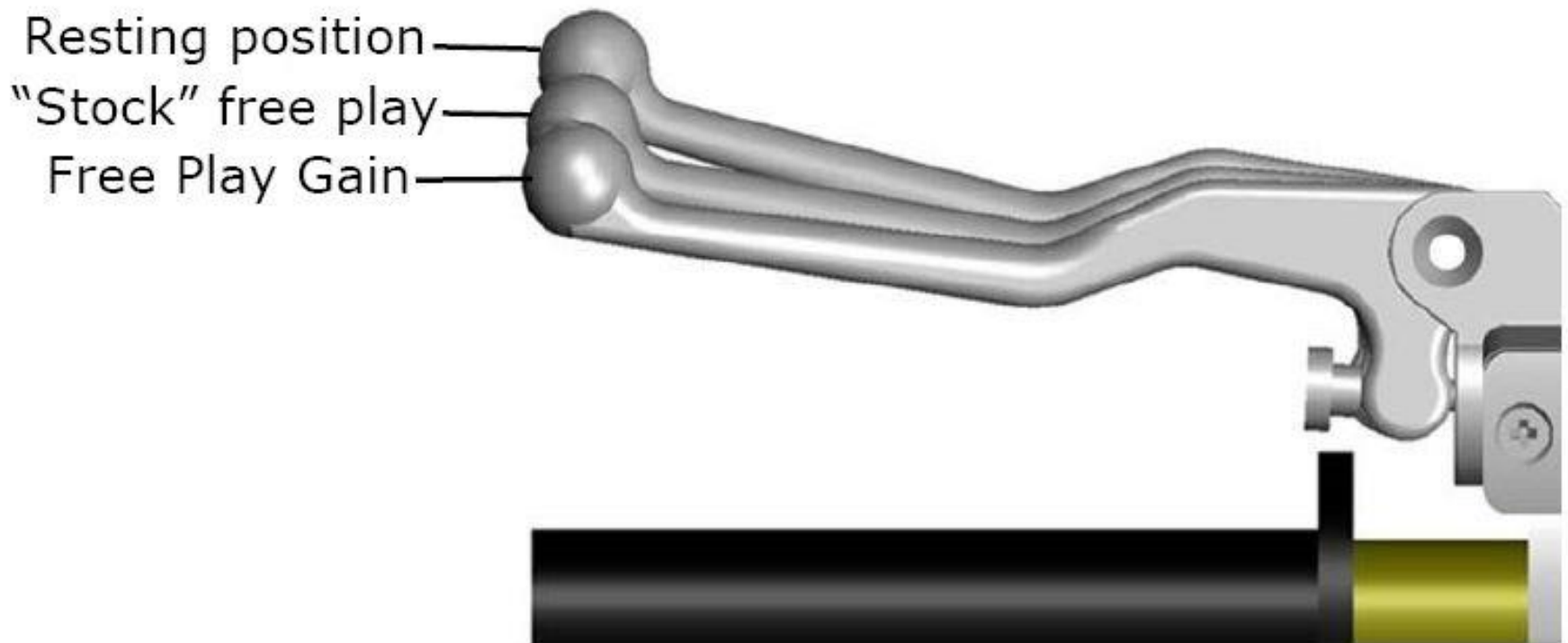

Optimal Free Play Gain yields **1/8-1/4” (3mm-6mm)** of clutch lever movement, measured at the end of the lever. This measurement at the lever correlates to achieving the ideal installed gap.

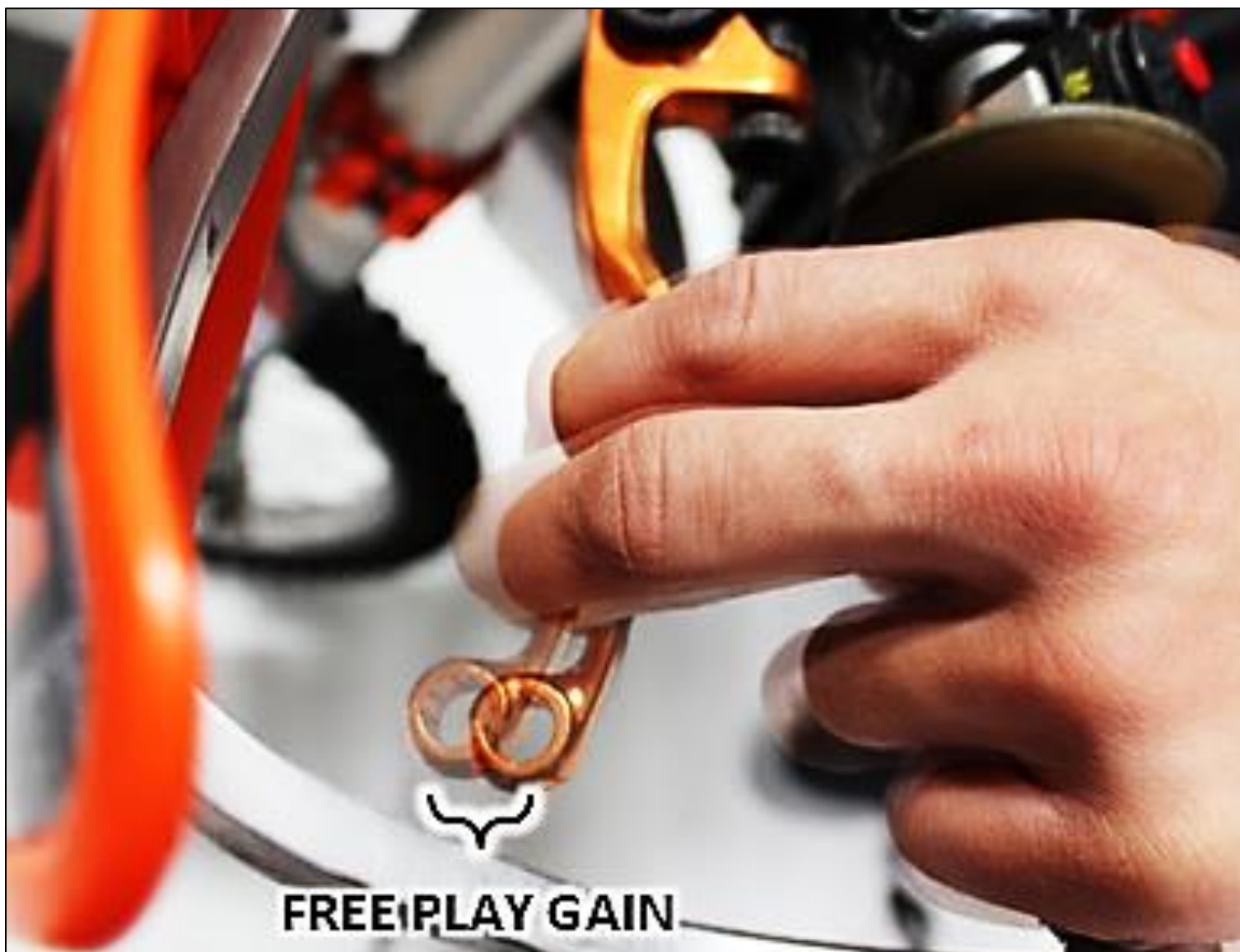

The following steps explain two ways to check Free Play Gain. One will use the rubber band that has been included in the clutch kit and one explains using your hand, which you will perform before every ride.

Place the bike in neutral, start the engine and let it warm up for 2-3 minutes.

RUBBER BAND METHOD

We recommend that you use this method to find your initial “Free Play Gain” so you can see what it is. We recommend also checking it by hand as explained in the next step so you can check Free Play Gain both ways.

Wrap the included rubber band around the outer end of the handlebar grip and attach to the ball end of the clutch lever. See the following three photos for an example.



HAND METHOD

Free Play Gain can also be checked by using your hand and holding light pressure on the lever. With the bike at idle, pull on the clutch lever lightly with a single finger so the lever free play is taken up, but the clutch is not disengaged. While continuing to apply light pressure, rev the engine to at least 5000 RPM. **The clutch lever should move in 1/8 - 1/4” (3mm – 6mm) under your finger pressure as you rev the engine.**

NOTICE

If you are not getting the correct lever movement, see the “Free Play Gain Troubleshooting Guide” on the next page.

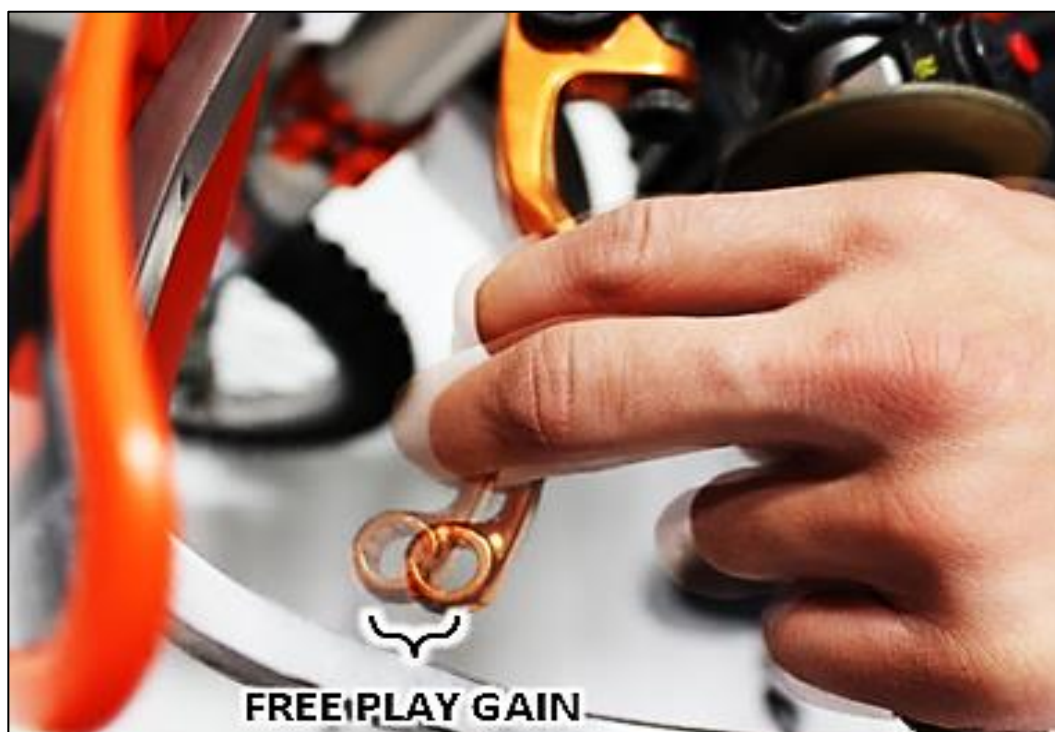

FREE PLAY GAIN TROUBLESHOOTING

Each adjustment should be done in small increments - one tick mark at a time. After each adjustment, repeat the rev-cycle until optimal Free Play Gain is achieved.

Symptom:

- Clutch lever moves in too far (too much Free Play Gain)
- Clutch has excessive drag
- It is difficult to fully override the clutch with the lever

Answer: Installed Gap is too small

Solution: Turn the Adjuster Screw inwardly (clockwise) to increase the Installed Gap.

Symptom:

- Clutch lever does not move enough or does not move at all (too little Free Play Gain)
- Clutch is slipping

Answer: Installed Gap is too large

Solution: Turn the Adjuster Screw outwardly (counterclockwise) to reduce the Installed Gap. It may be helpful to re-find the starting point.

BREAK-IN PROCEDURE

After desired Free Play Gain is achieved, it is time to break in the EXP disk.

REV CYCLES: With the transmission in neutral and no pressure on the clutch lever, rev the engine to about 5000 rpm and let it return to idle. Perform 10 rev cycles.

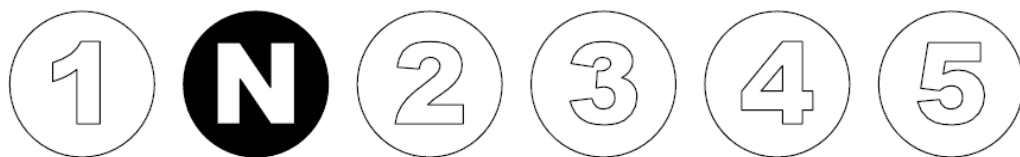

ROLL-ON STARTS: Pull in the clutch lever and click the transmission into first gear. Slowly release the clutch lever. The engine should stay running and the bike should have minimal forward creep. If the engine wants to stall or the creep is excessive, the idle may be too high or the installed gap may be too small. Make necessary adjustments before proceeding.

FIRST GEAR: Slowly roll on the throttle to begin moving. Accelerate to around 5000 rpm and come to a stop. Perform 10 first gear roll-on starts.

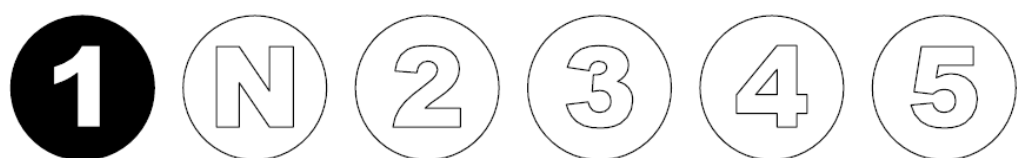

SECOND GEAR: Click the transmission into second gear and perform 10 roll-on starts.

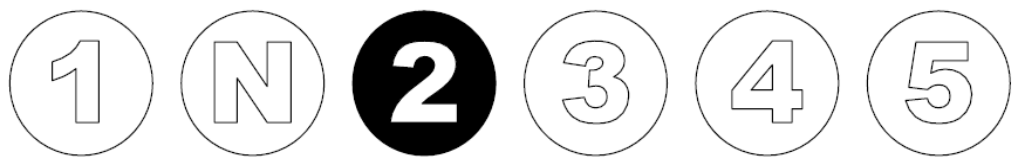

Re-check Free Play Gain and adjust if necessary.

4 strokes only: It is normal for some clutch debris to be produced during break in. Following break-in, remove the OEM oil screen beneath the shift lever. Inspect the screen for clutch debris and clean if necessary.

⚠ WARNING

Failure to follow the break-in procedure and oil screen inspection process could cause motor oil delivery failure which can result in motor failure, serious injury, or death.

NOTICE

Check Free Play Gain before every ride.

Do not perform 3rd gear starts with this product. 3rd gear starts over time will burn up the clutch and decrease the performance of this product in a short amount of time.

⚠ WARNING

DO NOT RIDE WITHOUT SUFFICIENT FREE PLAY GAIN!
Checking Free Play Gain is easy and takes less than a minute to perform. For optimum performance and longevity, check Free Play Gain when the bike is warm at the start of every ride.

MAINTENANCE

Maintenance Protocol (see setup sheet)	Maintenance Interval
Check and verify Free Play Gain	Every ride
Inspect all clutch parts for excessive wear or heat. Replace as needed.	Refer to OE service manual
Change oil, inspect and clean oil screen	Refer to OE service manual

OPTIMIZING EXP ENGAGEMENT

For best performance, engine idle speed should be **slightly** adjusted to match the EXP engagement setting.

NOTE: Make sure Free Play Gain is optimal before adjusting idle speed.

With correct Free Play Gain and the bike in gear, the bike should move forward under slight opening of the throttle. If not, one of the following symptoms is likely:

- HIGH IDLE – the bike moves forward with the throttle fully closed. Solution: reduce idle RPM.
- LOW IDLE – the bike moves forward after engine RPM becomes noticeably higher than idle RPM. Solution: increase idle RPM.

NOTICE

If a slight idle adjustment does not alleviate the problem refer to the EXP tuning options below for an additional tuning.

EXP TUNING OPTIONS

Included are spring options to tune the engagement RPM of the EXP disk. The EXP disk comes set with the recommended “**Medium**” setting from Rekluse.

NOTICE

Some 450/500/501 4-stroke models may be set by dealers to an idle lower than the manufacture recommendation. For idle speeds at 1650 RPM \pm 50 refer you will need to move to a lower setting

Configuration chart

EXP Springs Settings	
6 Silver	
3 Silver &	3 Red
6 Red	
3 Red &	3 Blue
6 Blue	
3 Blue &	3 Gold
6 Gold	
3 Gold &	3 Green
6 Green	
3 Green &	3 White

LOW SETTING



HIGH SETTING

Adjusting the engine idle speed to match your engagement setting is important and greatly affects the overall feel of how the EXP disk engages. To prevent freewheeling and maximize engine braking, set the idle so there is a slight amount of drag while the bike is idling in gear and warmed up. The idle should not be so high as to move the bike forward in gear with the throttle closed. However, with a small opening of the throttle the bike should move forward.

It is **NOT necessary** to disassemble the EXP halves to change springs! To change springs, remove 3 of the ¼-turn pins from one side of the EXP, replace springs, and re-install ¼-turn pins. Next, flip the EXP disk over and repeat on the other side if necessary. To maintain even pressure when using two different color spring sets, install one color set of 3 on one side of the EXP and the remaining color set of 3 on the other side.

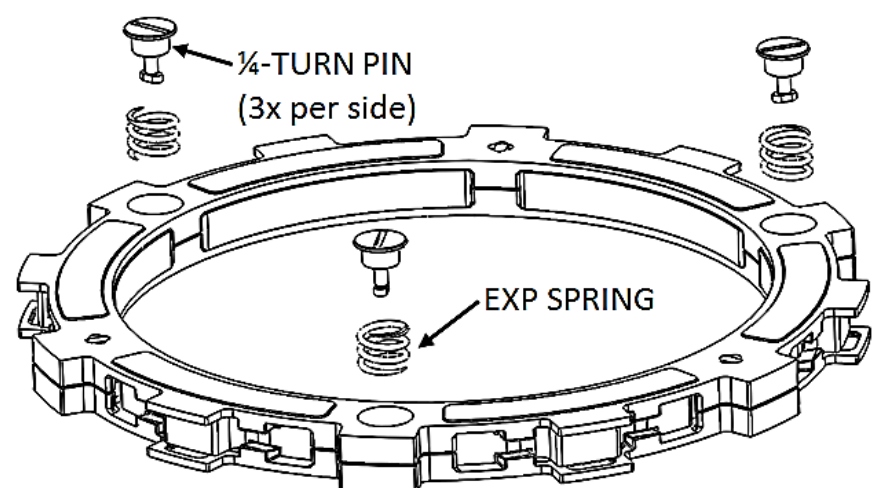

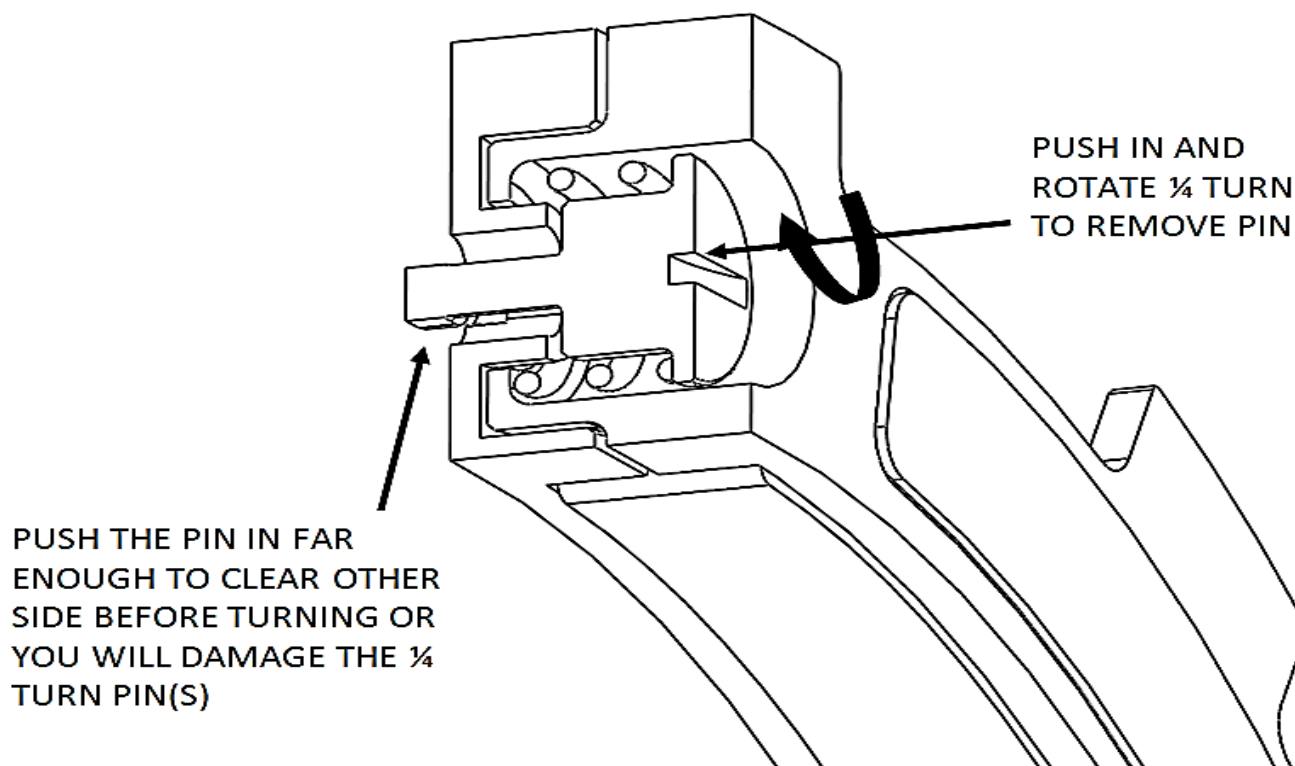

CLUTCH SQUEEL AND CHATTER

Although it is harmless, some bike models may have “squeal” or “chatter” coming from the clutch at low RPM as it engages. Clutch squeal is caused by the clutch components vibrating as the clutch engages and can become more audible as the clutch gets hot. For bike models that tend to have clutch squeal or chatter here are some recommendations to reduce or eliminate it:

- Oil: For optimal clutch performance Rekluse recommends using fresh, clean oil that **meets JASO-MA** oil rating requirements. Rekluse offers Factory Formulated Oil™ developed specifically for Rekluse products. Dirty or old oil can make the clutch more likely to squeal or chatter.

BUMP-STARTING INSTRUCTIONS

If your vehicle needs to be bump-started due to a dead battery or any other reason, follow the steps below to quickly bump-start your vehicle.

1. Use your adjustable slave cylinder to collapse the gap until no resistance is felt.
2. Bump start the vehicle. The clutch will function like a manual clutch at this point, but the clutch will not be fully over-rideable at high RPMs.
3. Once the vehicle is started, readjust the gap to set the installed gap.

NEED ADDITIONAL HELP?

Website

www.rekluse.com/support

Frequently asked questions

www.rekluse.com/faq

Support Videos

www.rekluse.com/support/videos

Phone

(208) 426-0659

Technical Support

Contact Technical Support for questions related to product installation, tuning, and performance.

Hours:

Monday thru Friday: 8:00 a.m. - 5:00 p.m.

Mountain Time zone

Email: tech@rekluse.com

Customer Service

Contact Customer Service for additional product information, orders, and returns.

Hours:

Monday thru Friday: 8:00 a.m. - 5:00 p.m.

Mountain Time zone

Email: customerservice@rekluse.com



SETUP SHEET 198-6313001

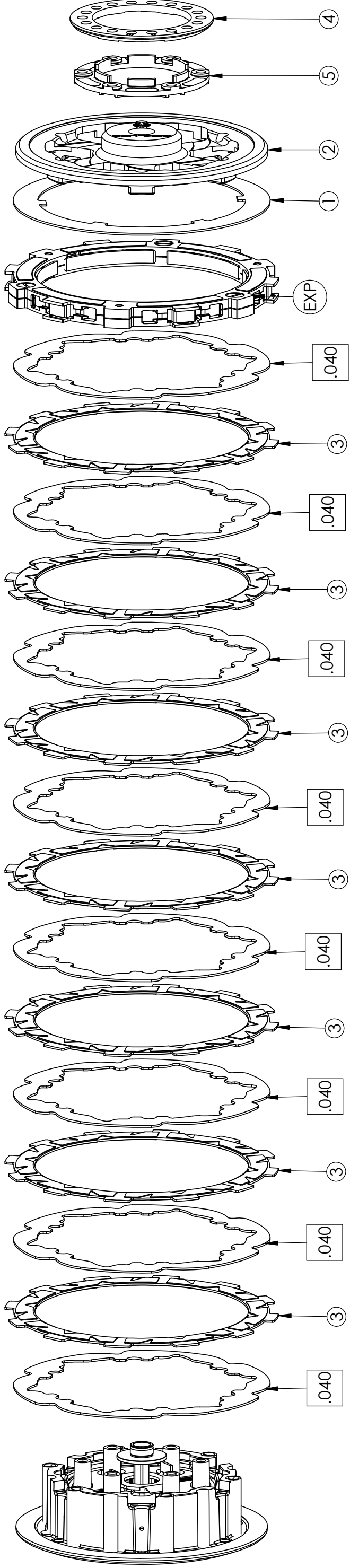

ITEM NO.	DESCRIPTION	QTY
1	LINING PLATE [.040"/1.0mm THICK]	1
2	PRESSURE PLATE	1
.040	TEC DRIVE PLATE [.040"/1.0mm THICK]	8
3	TORQDRIVE FRICTION DISK	7
EXP	EXP DISK	1
4	OEM SPRING RING	1
5	PRESSURE RING SPACER	1

The OEM spring ring has different settings to account for variances in the clutch pack and wear. The optimal setting depends on the thickness of the clutch pack. In general, MORE preload on the spring results in LESS clamping force, which in turn provides a lighter lever pull and less aggressive clutch performance. LESS preload on the other hand provides MORE clamping force, a heavier clutch pull, and more aggressive clutch performance. See the "Spring Ring Optimization Table" for recommended optimized setting based on clutch pack thickness.

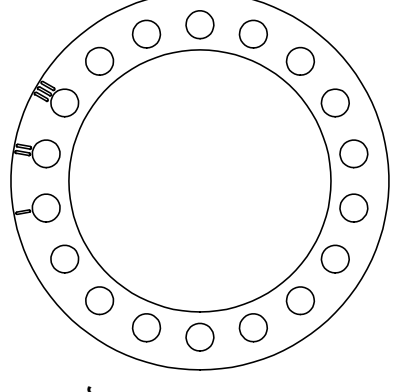

PACK THICKNESS [IN/mm]	SPRING RING SETTING
1.253 - 1.262 (31.8 - 32.1)	III OR Z
1.237 - 1.252 (31.4 - 31.8)	II OR Y
<1.236 (<31.4)	I OR X

