



# **INSTALLATION & USER'S GUIDE**

RadiusX Clutch  
for Cable Actuated Bikes and ATVs

Doc ID: 191-6300B  
Revision: 101722

# **TABLE OF CONTENTS**

OVERVIEW .....	2
INSTALLATION TIPS .....	3
TOOLS NEEDED.....	4
INCLUDED PARTS .....	4
DISASSEMBLING THE CLUTCH .....	5
INSTALLING THE CLUCK PACK .....	8
Notes for Clutch Pack Installation .....	8
Install Clutch Pack.....	10
SETTING THE INSTALLED GAP.....	15
CHECKING FREE PLAY GAIN .....	15
Learning How to Check the Free Play Gain .....	15
Two Methods to Check Free Play Gain .....	16
The Rubber Band Method.....	16
The Hand Method .....	17
ADJUSTING THE INSTALLED GAP .....	19
TUNING THE EXP.....	21
Changing the EXP Springs .....	21
BREAKING-IN THE NEW CLUTCH.....	23
OPTIMIZING THE CLUTCH LEVER.....	25
Optimization with OE Perch Adjuster.....	25
Optimizing the Rekluse Adjustable Reach Lever.....	26
MAINTENANCE.....	27
Clutch Wear .....	27
Clutch Parts.....	28
Basket .....	28
Disk Inspection Examples .....	29
NEED ADDITIONAL HELP?.....	30

## **OVERVIEW**

The parts in this kit are designed specifically for your motorcycle to optimize performance. This kit will replace several OE (Original Equipment) components with high-quality Rekluse components.

- The OE friction disks and drive plates will be replaced with a Rekluse thin friction EXP clutch pack.
- The OE pressure plate springs will be replaced with Rekluse springs.

## **INSTALLATION TIPS**







- Read the included **Safety Information** document before operating the vehicle with the product installed.
- Read this entire document before performing any steps.
- If you install this product for a customer or another person, instruct them to read the **Safety Information** document and the **Installation and User Guide** before operating the vehicle with the product.
- Protect your eyes and skin – wear safety glasses and work gloves.
- Lay the motorcycle on its left side when replacing the clutch. This makes working on the clutch easier and eliminates the need to drain the oil. Catch any fuel that may drain from the bike.
- Drain the oil from an ATV before installing the clutch.
- Use the torque specifications found in your OE service manual.
- For optimal clutch performance, Rekluse recommends using fresh, clean oil that **meets JASO-MA** oil rating requirements. Rekluse offers Factory Formulated Oil™ developed specifically for Rekluse products. Rekluse Factory Formulated Oil is a perfect complement to any



OEM or aftermarket wet clutch. Visit [www.rekluse.com](http://www.rekluse.com) to learn more.

- **This clutch pack is not legal to race with in the AMA Limited or Stock class.**

## **TOOLS NEEDED**

			
10 mm socket	8 mm socket	Metric Wrench	Torque Wrench
			
Pick	Fluid Catch Container	4 mm Hex key	

## **INCLUDED PARTS**

The parts included in the kit depend on the bike or ATV model. See the included sheet **Setup Sheet** for a list of included parts and diagram.

You can also visit our website at [www.rekluse.com/support](http://www.rekluse.com/support) for a full parts fiche diagram and part numbers.

# **DISASSEMBLING THE CLUTCH**

1. Soak the Rekluse friction disks in new oil for at least 5 minutes. Make sure the friction disks are coated on both sides.

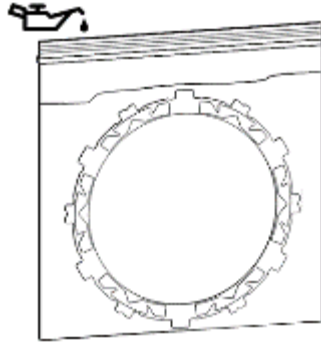

2. If applicable, turn the fuel petcock to “OFF.”

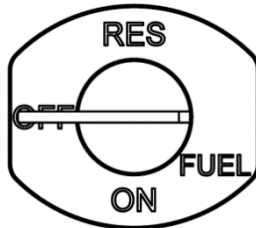

3. For bikes, lay the bike on its left side. Catch any fluids that might drain into a suitable container. For ATVs, drain the oil into a suitable container before disassembly.



4. Remove the OE clutch cover and set it aside. **It will be reused.**
5. Remove the OE pressure plate bolts, springs, and pressure plate. **Set them aside; they may be reused.**

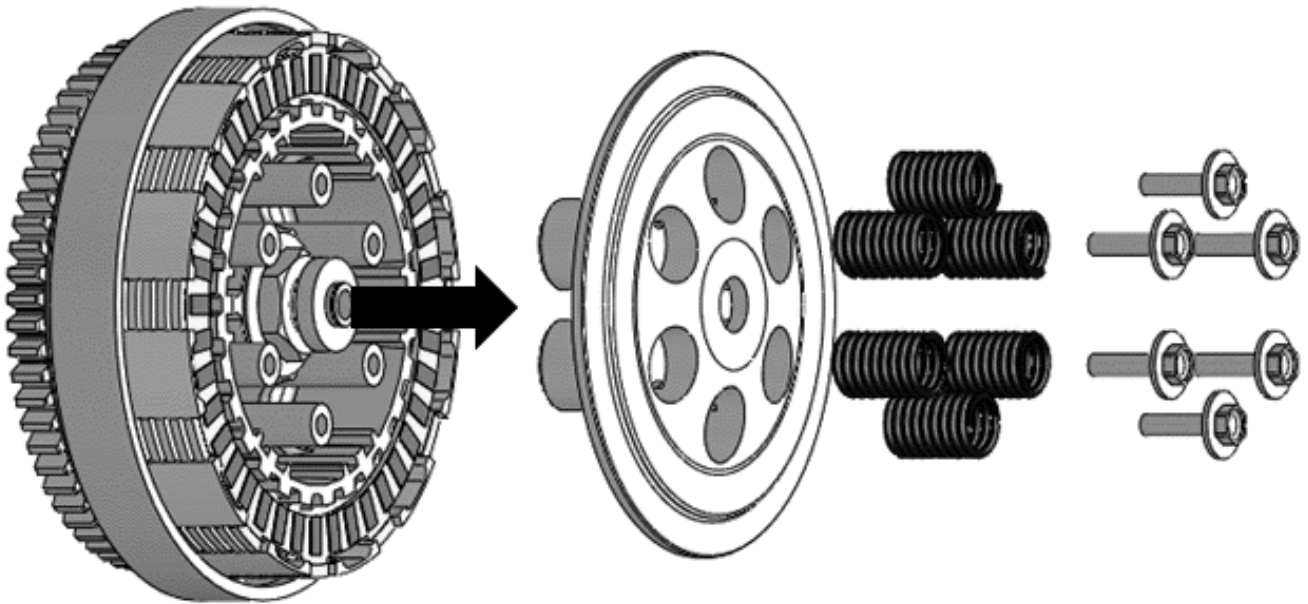

**Note:** *Throw-out washers can stick to the back of the pressure plate. Be sure to reinstall any throw-out washers back onto the throw-out.*

6. Remove the clutch pack.

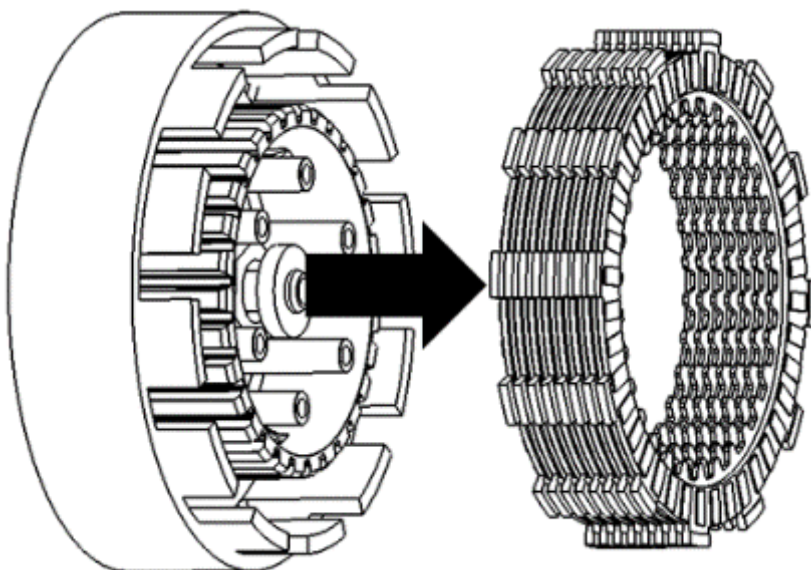

**Note:** Some models have a judder spring (clutch boss spring), a spring seat, and a narrow friction located in the bottom of the OE friction pack. If your model is equipped with these parts, remove them and **set the spring aside**. Refer to the included **Setup Sheet** to determine if your model reuses any of these parts.

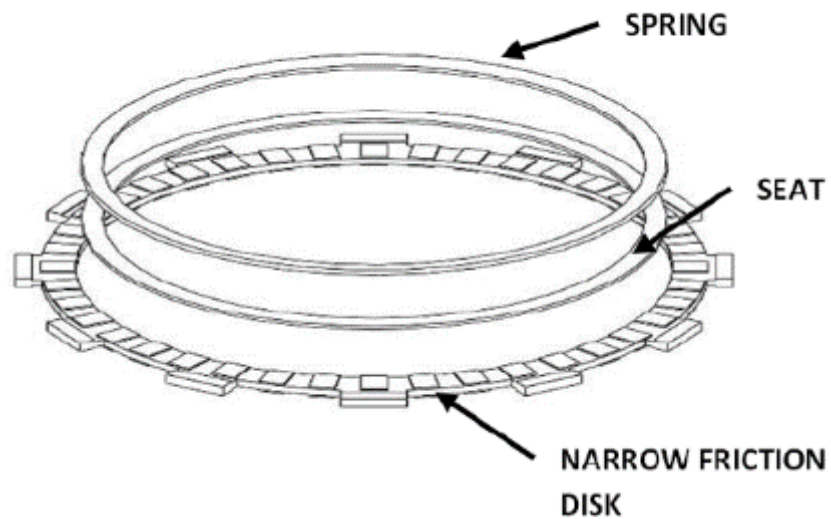

# **INSTALLING THE CLUCK PACK**

## **Notes for Clutch Pack Installation**

- *Some OE baskets have “half slots” at the top of the basket tangs. Rekluse products require the entire clutch pack be installed into the MAIN (deeper) basket slots. Do not use the “half slots” (see below).*



- *Inspect the clutch basket for damper and/or spring play.*
- *Inspect the clutch basket for notching. Do not install sleeves or use this product with a notched basket. Notched basket tang faces can cause the sleeves to break. Do not use baskets that have been filed, machined, or modified on the tangs. Replace basket if necessary.*

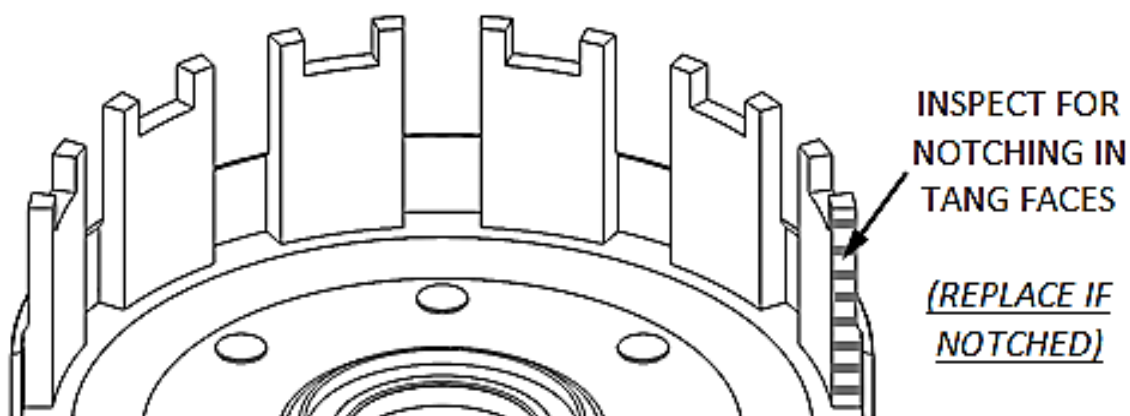

### **⚠ WARNING**

**Failure to inspect the basket and replace if necessary could result in death, serious injury, and/or property damage.**



**Note:** If the basket is notched or worn, Rekluse recommends replacing it with a Rekluse Billet Clutch Basket (available for most models).



- *Inspect your OE center hub and pressure plate flanges for excess wear. If wear is visible use a drop gauge to verify that the wear across the flange does not exceed .005" (.12mm).*

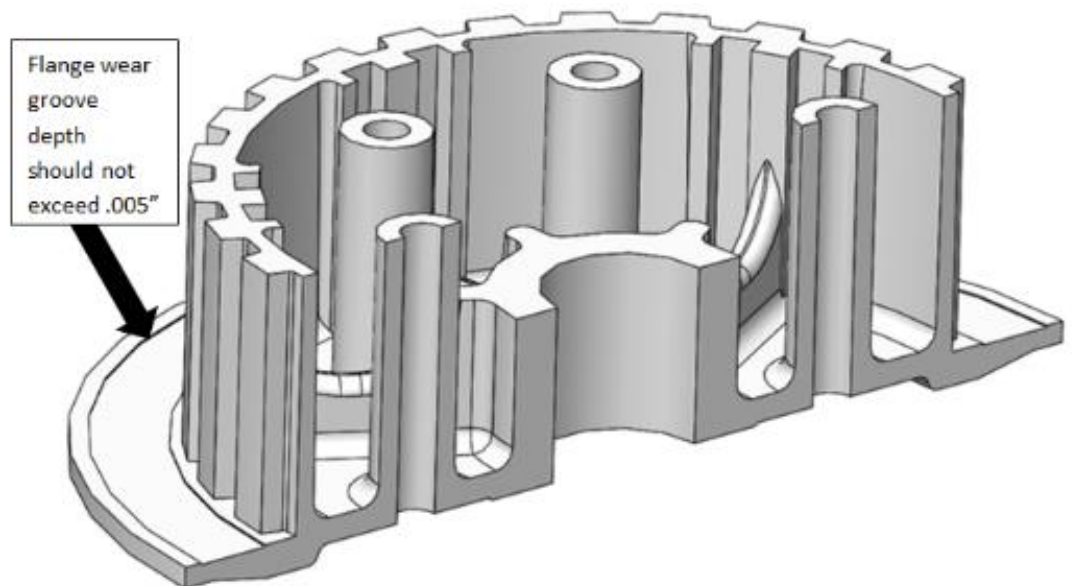
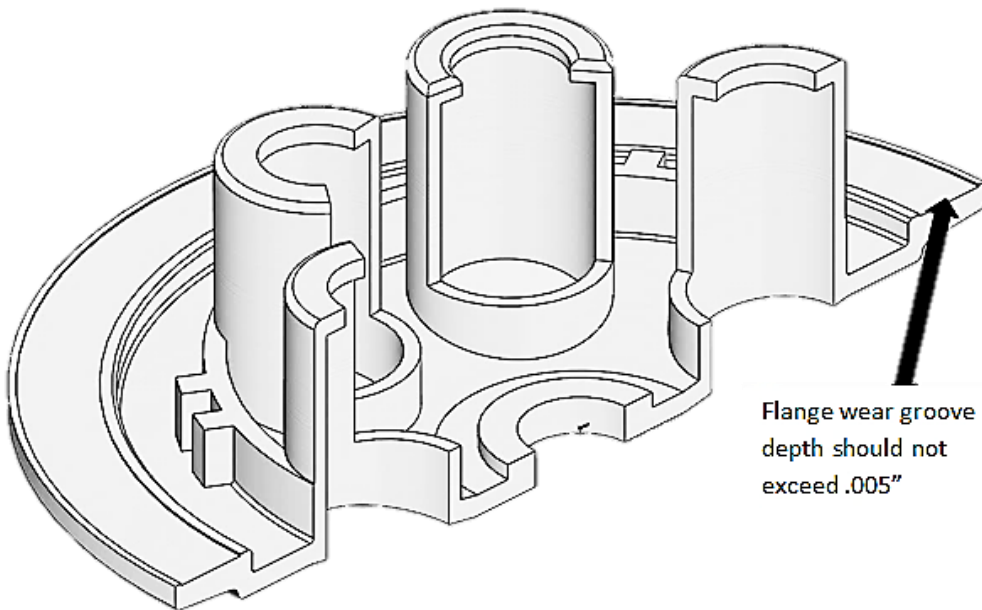

- *Some friction disks are marked with a small colored dot. This mark is used for processing and can be ignored.*

# Install Clutch Pack

1. Install all of the Rekluse basket sleeves into the basket slots. Make sure the bottom of the sleeve is facing down, and the sleeve tabs sit against the inside of the basket.

Sleeve tabs sit inside the basket

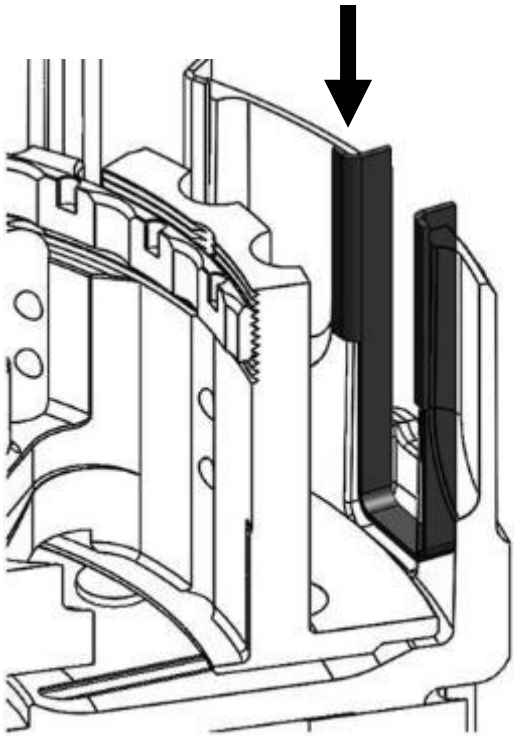

Install all the basket sleeves

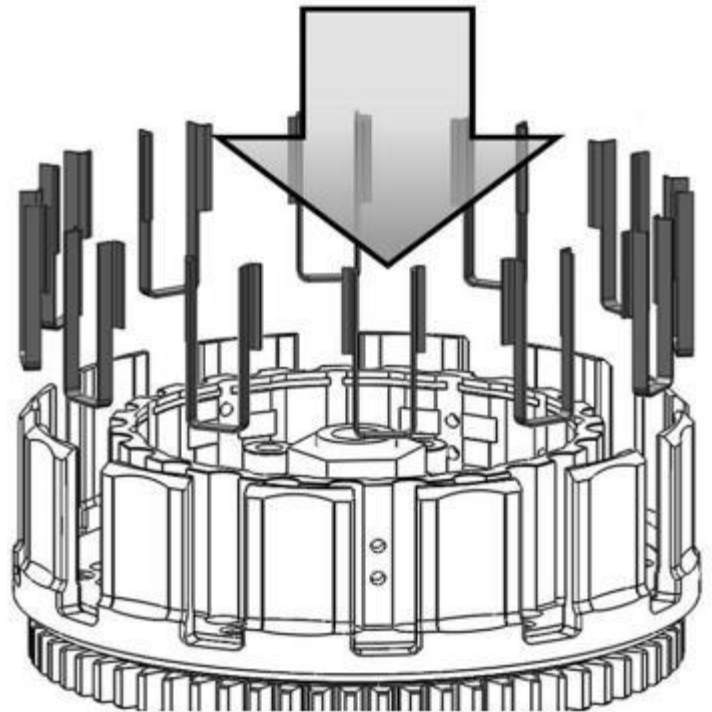

**Note:** When seated in the basket, the sleeve tops may sit slightly above or below the top of the basket.

2. If the included **Setup Sheet** indicates your bike or ATV reuses the judder spring, reinstall **only the judder spring**, cupped side up.
3. Install the Rekluse clutch pack. The clutch pack varies depending on the bike or ATV model. **See the included Setup Sheet for the proper clutch pack configuration.**

4. If your kit includes a Rekluse throw-out spacing washer, install it on top of your OE throw-out as indicated by the included **Setup Sheet**.

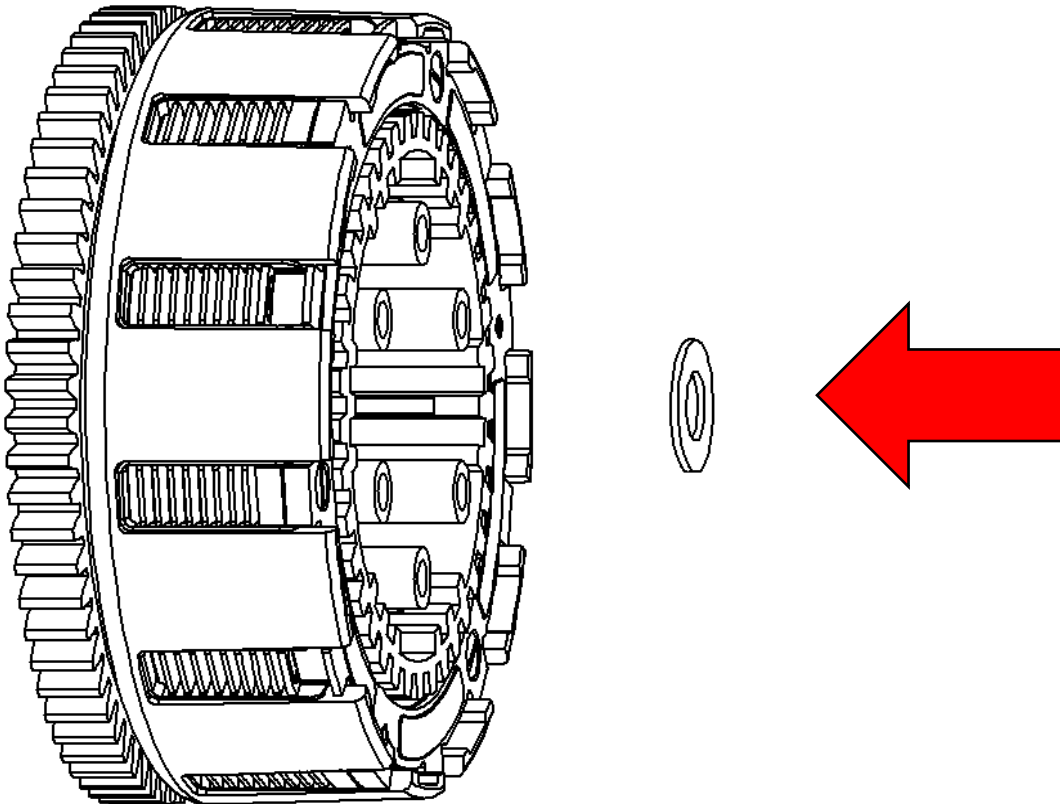

**⚠ CAUTION**

**Suzuki RM-Z450 Models:** The needle bearing only has the bearings on one side. Make sure that the bearing side is facing the throw-out and the flat side is facing the pressure plate.

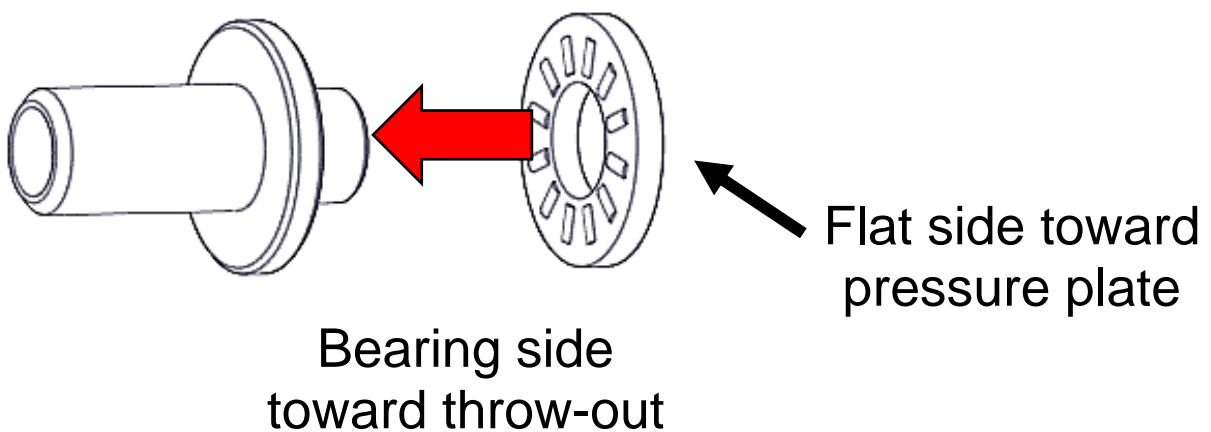

5. Reinstall the pressure plate, then install the Rekluse pressure plate springs and OE bolts.

**Note:** For Yamaha YZ250F (2019+), YZ250FX (2020+), & WR250F (2020+) when installing the pressure plate align the indent in the pressure plate with the indent in the center hub.

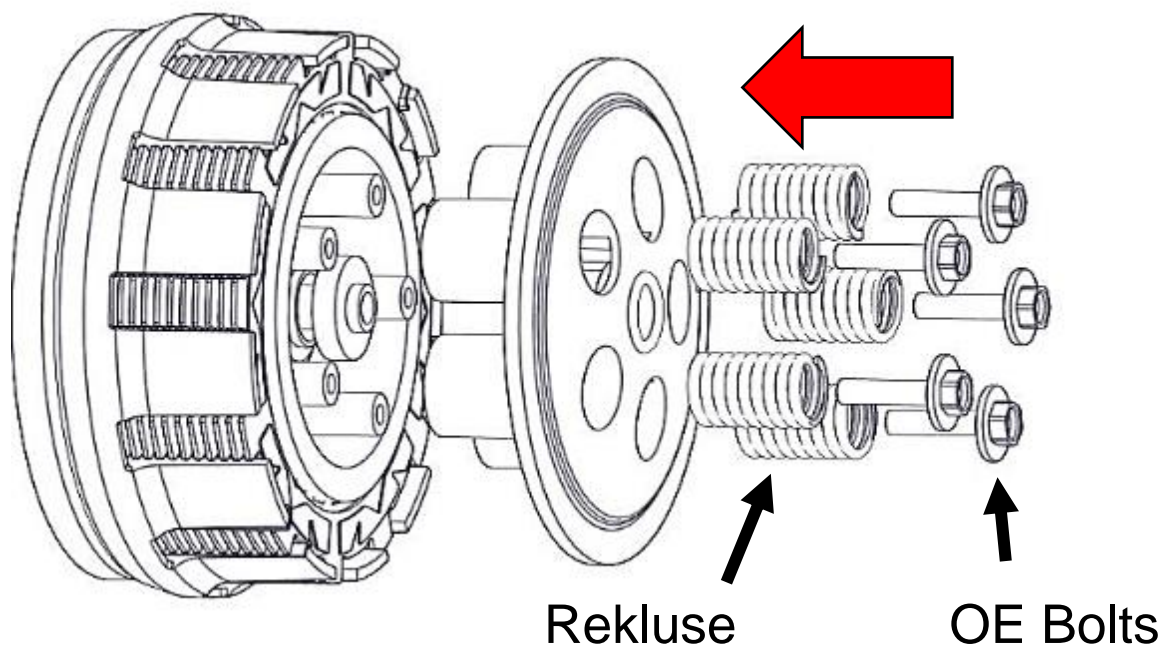

**Note: DRZ 400, KLX 400, KX 500 bike models:**

If your kit includes Rekluse screw sleeves or spring bolts, install them in place of the OE components. The DRZ 400 and KLX 400 models will utilize the supplied Rekluse screw sleeves and OE bolts, and KX 500 models will utilize supplied Rekluse screw sleeves and Rekluse bolts.

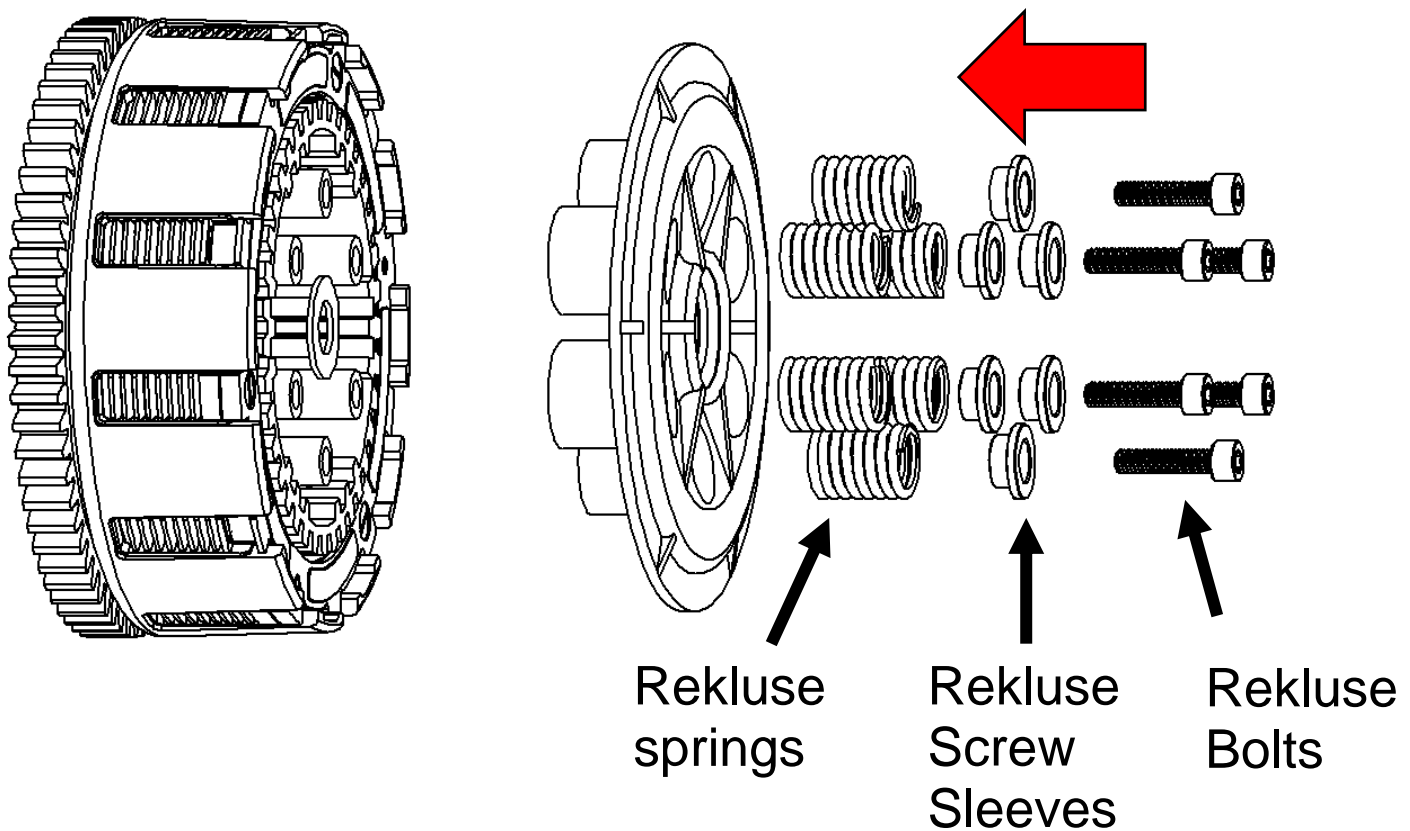

**Note:** *If the clutch kit includes 2 different pressure plate spring colors, install them in an alternating pattern. This will ensure an even force is applied to the pressure plate and clutch.*

6. Tighten the pressure plate bolts in a star-pattern to the OE torque specifications. Tighten each bolt in small increments, following a star-pattern.
7. Reinstall the OE clutch cover gasket.
8. Reinstall the clutch cover, then reinstall the cover bolts. Tighten the cover bolts in a star-pattern to the OE torque specifications. Tighten each bolt in small increments, following a star-pattern.



# **SETTING THE INSTALLED GAP**

1. The clutch lever should be tight against the perch. If not, adjust the cable so that the lever is tight against the perch.
2. Turn the cable and/or perch adjuster 3-5 turns tighter. Tightening beyond the initial perch adjustment creates the installed gap.
3. Continue the installation by checking for Free Play Gain.

## **CHECKING FREE PLAY GAIN**

The proper installed gap is verified by checking Free Play Gain.

**Correct Free Play Gain = Correct installed gap**

Setting up, breaking-in, and rechecking the installed gap is **CRUCIAL**. Failure to properly maintain the installed gap can result in premature wear or failure of the clutch.

### **⚠ WARNING**

**Failure to check and verify Free Play Gain can cause failure or damage to this product. Setting the correct installed gap is critical for clutch performance.**

## **Learning How to Check the Free Play Gain**

If you are familiar with checking Free Play Gain, skip to the “*Adjusting the Installed Gap*” section.

If Free Play Gain is new to you, follow the instructions below. You can also view the video titled “*How to Check Free Play Gain*” on our website at [www.rekluse.com/support/videos](http://www.rekluse.com/support/videos).

**Optimal Free Play Gain yields 1/8”-1/4” (3 mm-6 mm) of clutch lever movement**, measured at the ball end of the lever. This measurement at the lever correlates to achieving the ideal installed gap.

# Two Methods to Check Free Play Gain

There are two ways to check for Free Play Gain. One way uses the rubber band Rekluse includes in the clutch kit, and one uses your hand. You can use either method to check for Free Play Gain.

## The Rubber Band Method

Use the rubber band method for the initial set up. It can also be used before each ride until you feel comfortable checking the Free Play Gain using the hand method.

### **⚠ WARNING**

**BEFORE YOU BEGIN, verify that the bike or vehicle is in NEUTRAL before checking Free Play Gain. Failure to do so may result in the bike or vehicle lurching forward, and loss of control and/or injury may result.**

**A Rekluse auto-clutch can make your motorcycle or vehicle appear to be in neutral when in gear, even when the engine is running and clutch lever released.**

**Motorcycles or vehicle equipped with a Rekluse auto-clutch can move suddenly and unexpectedly and cause riders to lose control. To avoid death, serious injury, and/or property damage, always sit on the motorcycle or ATV to start it.**

a) Before you begin, place the bike/ ATV in **NEUTRAL**, start the engine and let it warm up for 2-3 minutes to idle down and warm the engine oil.

b) Stretch the included rubber band between your thumbs, and then place the top end of the rubber band on the outer end of the left handlebar grip.





c) While holding the top end of the rubber band against the handlebar, stretch the band downward, and then loop it through itself.



d) Pull the band through the loop, and then attach it to the outside end of the clutch lever.



e) While still in **NEUTRAL**, quickly rev the engine between 5,000-7,000 RPM (1/2 to 3/4 throttle), then let it return to idle. Notice the movement in the clutch lever when the engine is revved. This is your Free Play Gain.

**Note:** *It is very important the motor returns to idle before revving the engine again or the Free Play Gain will not be correct.*

f) When the bike/ATV returns to idle, rest your hand across the clutch lever. Rev the engine again to 5,000-7,000 RPM so you can observe the movement while feeling for Free Play Gain with your hand.

## The Hand Method

- a) Before you begin, place the bike/ATV in **NEUTRAL**, start the engine and let it warm up for 2-3 minutes to idle down and warm up the engine oil.
- b) With the bike/ATV at idle, use one finger to apply pressure at the end of the clutch lever.

- c) While still in **NEUTRAL**, continue to apply light pressure and quickly rev the engine between 5,000-7,000 RPM (1/2 to 3/4 throttle), then let it return to idle. Notice the movement in the clutch lever when the engine is revved. This is your Free Play Gain.
- d) When the bike/ATV returns to idle, rev the engine between 5,000-7,000 RPM a second time to verify the Free Play Gain again.

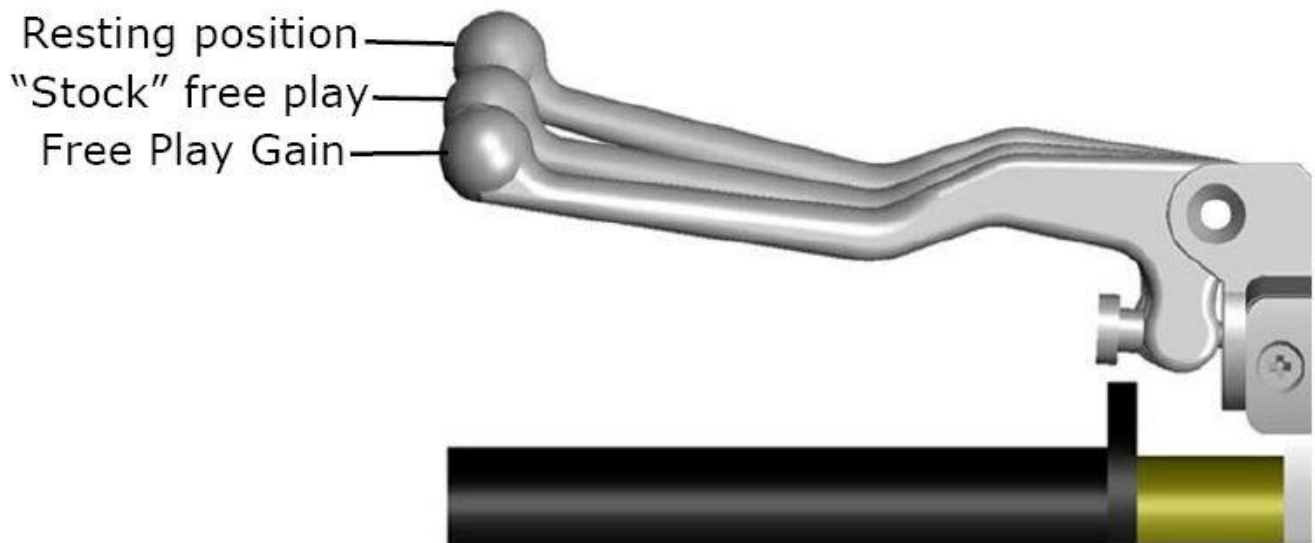

# **ADJUSTING THE INSTALLED GAP**

After checking for Free Play Gain, you may need to adjust the installed gap. If the Free Play Gain is optimal, continue to “Breaking-In the New Clutch”. If the Free Play Gain is not optimal, the installed gap needs to be adjusted.

The installed gap should be fine-tuned in small increments and then recheck Free Play Gain. Refer to the table below to set the proper installed gap based on your Free Play Gain.

**Notes:** *If you are unable to obtain the correct Free Play Gain or you are nearly out of cable adjustment after performing the adjustment, your cable may be worn or stretched from wear or use. If this is the case, the cable should be replaced.*

## Adjust the Installed Gap

Symptom	Reason	Solution
<ul style="list-style-type: none"> <li>• Clutch lever moves in too far (too much Free Play Gain)</li> <li>• Clutch has excessive drag or stalls</li> <li>• It is difficult to fully override the clutch with the lever</li> </ul>	<p>Installed gap is too small</p>	<p>Tighten the cable: increase the length of the in-line cable adjuster housing until the correct amount of Free Play Gain is achieved.</p> <p>Recheck Free Play Gain.</p>
<ul style="list-style-type: none"> <li>• Clutch lever only moves slightly or does not move at all (too little Free Play Gain)</li> <li>• Clutch slips</li> <li>• Bike/ATV seems to lose power</li> </ul>	<p>Installed gap is too large</p>	<p>Loosen the cable: Reduce the length of the cable housing (collapse the adjusters) until the correct amount of Free Play Gain is achieved.</p> <p>Recheck Free Play Gain.</p>

# **TUNING THE EXP**

This kit includes multiple spring settings to adjust the engagement RPM of the EXP friction disk. The EXP friction disk comes preinstalled with the recommended “Medium” setting. See the included Setup Sheet for a chart of the available EXP spring configurations.

You may have to adjust the engine idle speed to prevent free-wheeling and maximize engine braking. There should be a slight amount of drag when the bike is warmed up and idling in gear. The idle should not be so high that the bike moves forward while in gear with the throttle closed. However, with a small opening of the throttle, the bike should move forward.

## **Changing the EXP Springs**

1. Using a flathead screwdriver, push the  $\frac{1}{4}$  turn pin in far enough to clear the opposite side of the EXP to unlock the pin.
2. With the pin still pushed past the base, turn  $90^\circ$  to remove the pin and spring.
3. Remove the remaining 2 pins and springs from the same side of the EXP base.
4. Drop a new spring into the spring slot on the base, then add the  $\frac{1}{4}$  turn pin.
5. Push the  $\frac{1}{4}$  turn pin in far enough to clear the base, then turn  $90^\circ$  and release the pin. The pin should sit almost flush with the EXP base.
6. If necessary, repeat this process on the other side of the EXP to complete the spring configuration.

## NOTICE

When installing two different colors of springs, use only 1 color on each side. Install one set of 3 on one side of the EXP, then flip the EXP over and install the remaining set of 3 on the other side to maintain even pressure.

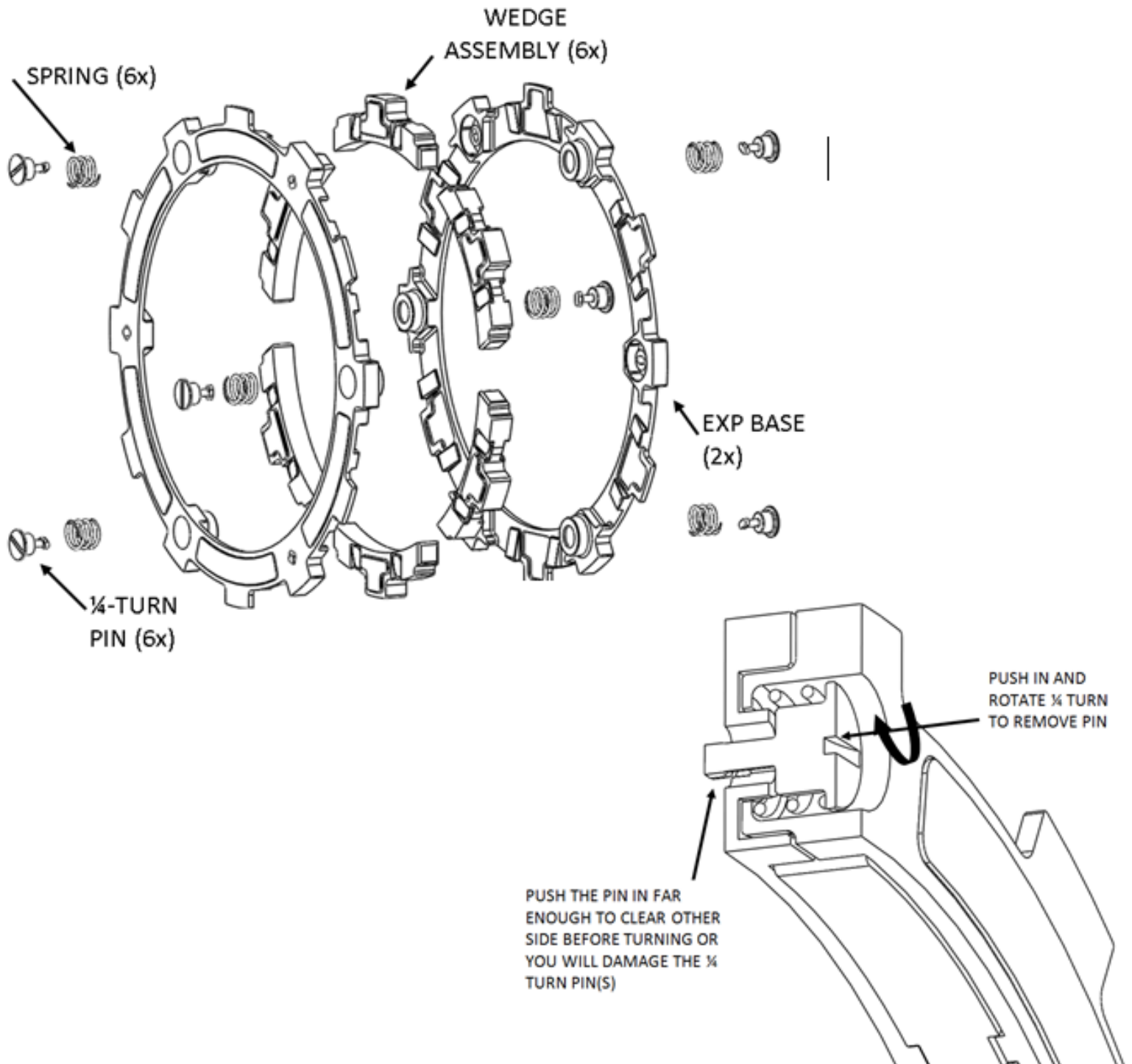



# **BREAKING-IN THE NEW CLUTCH**

Once you install your new clutch, it is important to break it in. A series of roll-on starts are used to break in the clutch. Follow these steps for breaking in your clutch and any time new friction disks, EXP bases, Teflon pads, or wedges are installed.

## **⚠ WARNING**

**Failure to follow the break-in procedure and oil screen inspection process could cause motor oil delivery failure, which can result in motor failure, serious injury, or death.**

Break-in Procedure	Number of times
<p><b>Rev Cycles:</b></p> <ol style="list-style-type: none"> <li>Place the bike or ATV in <b>NEUTRAL</b>.</li> <li>With your hand <b>off</b> the clutch lever, rev the engine 10 times, being sure to let it <b>return to idle</b> between each rev cycle.</li> </ol>	 <p>10 rev cycles</p>
<ol style="list-style-type: none"> <li>With the engine still running, pull in the clutch lever, then click the bike/ATV into 1<sup>st</sup> gear. Slowly release the clutch lever. The bike/ATV should stay in place or have a slight amount of forward creep.</li> <li>With the bike/ATV idling in first gear, slowly apply throttle to begin moving.</li> </ol>	<p><b>Continued on next page</b> </p>

5. Without using the clutch lever, accelerate moderately to approximately 5,000 RPM to fully lock up the clutch and come to a complete stop. Repeat 10 times.



10 roll-on starts

**Note:** *If the engine wants to stall or the creep is excessive, the idle may be too high or the installed gap may be too small. Make necessary adjustments before proceeding.*

6. Without using the clutch lever, start in 2<sup>nd</sup> gear, then accelerate moderately to approximately 5,000 RPM and come to a complete stop. Repeat 10 times.



10 roll-on starts

7. Place the bike or ATV in **NEUTRAL** and recheck Free Play Gain.



Recheck Free Play Gain and adjust the installed gap

8. Continue to step 4 to adjust the installed gap until the Free Play Gain of the clutch lever is 1/8" to 1/4" (3 mm-6 mm).

**Note:** *Your clutch pack will expand with heat, so final adjustment to Free Play Gain should be made when the bike or ATV is warm. Remember not to ride without sufficient Free Play Gain.*

**⚠ CAUTION**

**Do not perform 3<sup>rd</sup> gear starts with this product. Starting in 3<sup>rd</sup> gear will burn up the clutch and decrease the performance of this product in a short amount of time.**



# **OPTIMIZING THE CLUTCH LEVER**

If your bike model is not equipped with a perch adjuster bolt, you may purchase, as an option, a Rekluse Adjustable Reach Lever.

## **Optimization with OE Perch Adjuster**

Kits for Honda the CRF 450 and CRF 250 include a new perch adjuster bolt. Replace your OE perch adjuster bolt with the one included in your kit. These bolts will not be used on the CRF450RX.

Kits for Yamaha the YZ450F and YZ250F include a new perch adjuster bolt. Replace your OE perch adjuster bolt with the one included in your kit. These bolts will not be used on the YZ450FX and YZ250FX.

### **Adjust the lever:**

- Set the clutch lever to the desired reach point while maintaining clutch lever slack.
  - Turning your adjuster bolt farther in will bring the lever closer to the bar and allow for a closer reach point.
  - Backing your adjuster bolt farther out will push the lever farther from the bar and allow for a further reach point.

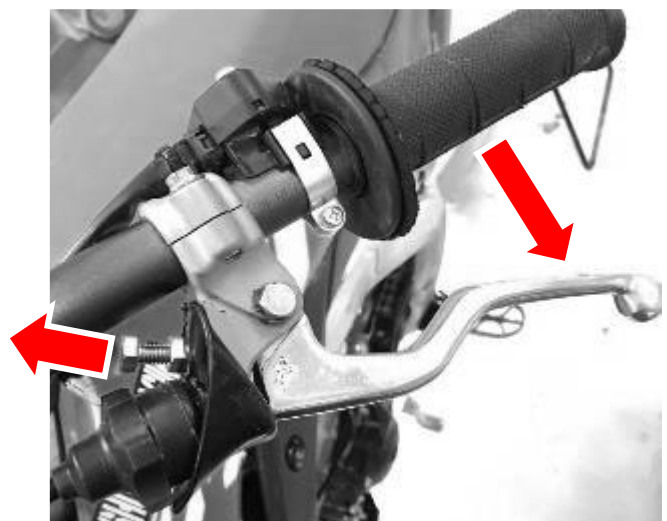
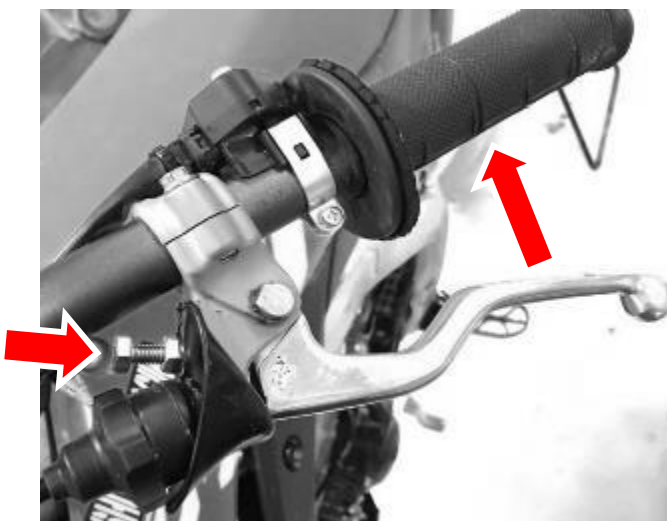

# Optimizing the Rekluse Adjustable Reach Lever

Set the clutch lever to the desired reach point while maintaining clutch lever slack.

- Turning your adjuster bolt farther in will push the lever farther from the bar and allow for a further reach point.
- Backing your adjuster bolt farther out will bring the lever closer to the bar and allow for a closer reach point.

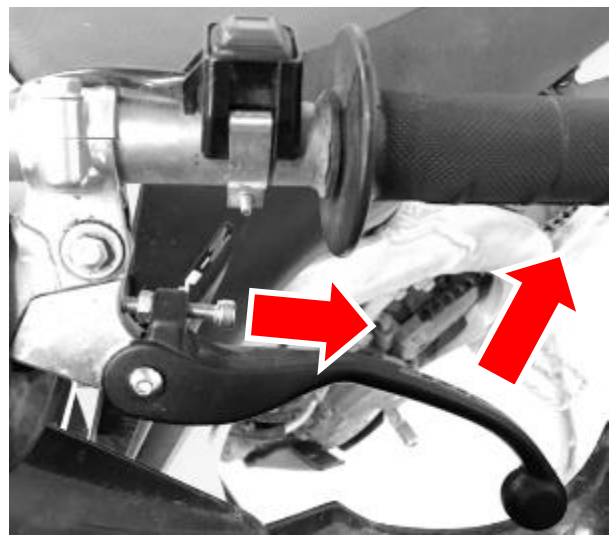
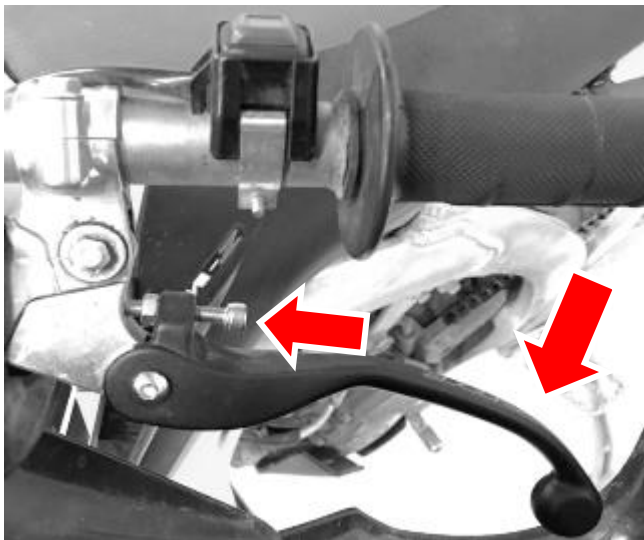

# **MAINTENANCE**

To keep your clutch performing at its best, perform regular maintenance on your bike or ATV and clutch.

## **Clutch Wear**

Rekluse clutches are built using high quality materials but do wear based on the rider's use, type of terrain, and natural wear and tear. To keep your clutch performing at its best, perform regular maintenance on your bike/ATV and clutch based on your riding style.

- Maintain adequate Free Play Gain. Check before every ride and adjust as necessary.
- Repeat the break-in procedure when you replace any components of the EXP disk or frictions disks. Always soak new friction disks in fresh oil before installing.

# Clutch Parts

- Regularly inspect and replace all clutch components showing signs of wear or excessive heat. Rekluse recommends inspecting after the first 10 hours of use, then every 20 hours after that.
- Measuring the clutch pack and the EXP disk can help determine if the components need to be replaced.
- Replace friction disks or drive plates if they are glazed or burnt. See the following section for examples.
- Regularly change the oil as per the bike/ATV manufacturer's recommendations. Clutch performance and longevity depend on oil quality. Oil recommendations can also be viewed under Tech Tips on our website at [www.rekluse.com/support/videos](http://www.rekluse.com/support/videos).

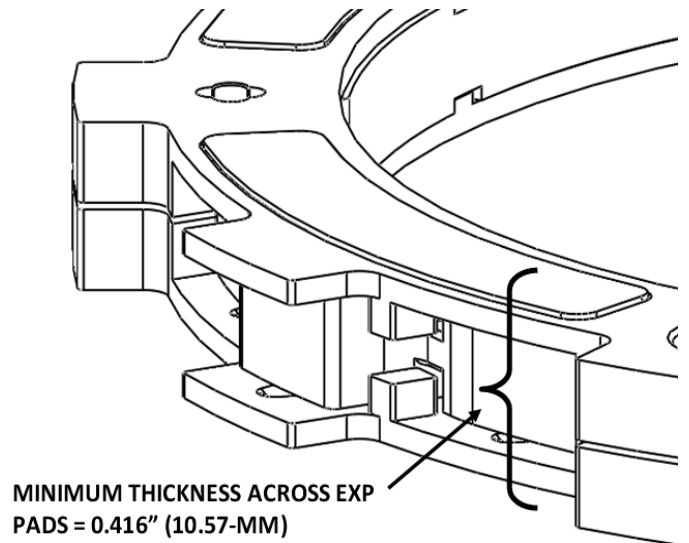

# Basket

- Inspect the basket dampers and springs by checking the play between the ring gear and the basket. Replace the dampers or springs if you feel any play in the assembly.
- Inspect and replace basket sleeves if they appear to be notched from the friction disks. Rekluse recommends replacing them every 25 hours for abusive riding or racing, every 50 hours for moderate riding, or every time friction disks are replaced.

# Disk Inspection Examples

When inspecting the clutch pack, the following pictures can be used as a reference. **These are best viewed in color by viewing this install document at:**

[www.rekluse.com/support](http://www.rekluse.com/support).

**Drive Plates** – If the clutch pack is getting high amounts of heat, purple, blue, or black color can be seen on the drive plate teeth. See pictures below. Not all drive plates look the same and may look different than pictured.



Normal Heat



High Heat  
(Blue)



Excessive Heat  
(Black)

**Friction Disks** – Due to the dark color of the friction material, the friction disks will appear almost black as soon as they are put in oil. During inspection, look for glazing of the friction material. Glazing will appear shiny and feel like glass, even after the oil is cleaned off the friction disk. Not all friction disks look the same and may look different than pictured.



Normal  
Friction



Glazed  
Friction

# **NEED ADDITIONAL HELP?**

## **Website**

[www.rekluse.com/support](http://www.rekluse.com/support)

## **Frequently asked questions**

[www.rekluse.com/faq](http://www.rekluse.com/faq)

## **Support Videos**

[www.rekluse.com/support/videos](http://www.rekluse.com/support/videos)

## **Phone**

(208) 426-0659

## **Technical Support**

Contact Technical Support for questions related to product installation, tuning, and performance.

### **Hours:**

Monday thru Friday: 8:00 a.m. - 5:00 p.m.

Mountain Time zone

Email: [tech@rekluse.com](mailto:tech@rekluse.com)

## **Customer Service**

Contact Customer Service for additional product information, orders, and returns.

### **Hours:**

Monday thru Friday: 8:00 a.m. - 5:00 p.m.

Mountain Time zone

Email: [customerservice@rekluse.com](mailto:customerservice@rekluse.com)



# CLUTCH SETUP SHEET

## Clutch pack configuration

Model	YFZ 450R
Qty of friction disks	8
Qty of drive plates	8 - 0.040 in (1 mm)
EXP disk	1

## Assemble the clutch pack

1. Place the thick friction disk into the clutch basket.
2. Add a .040 in (1.0 mm) steel drive plate, then add a thin friction disk.
3. Alternate 7, .040 in (1.0 mm) steel drive plates with the remaining 6 thin friction disks.
4. Place the EXP disk on top of the last .040in (1.0mm) steel drive plate.

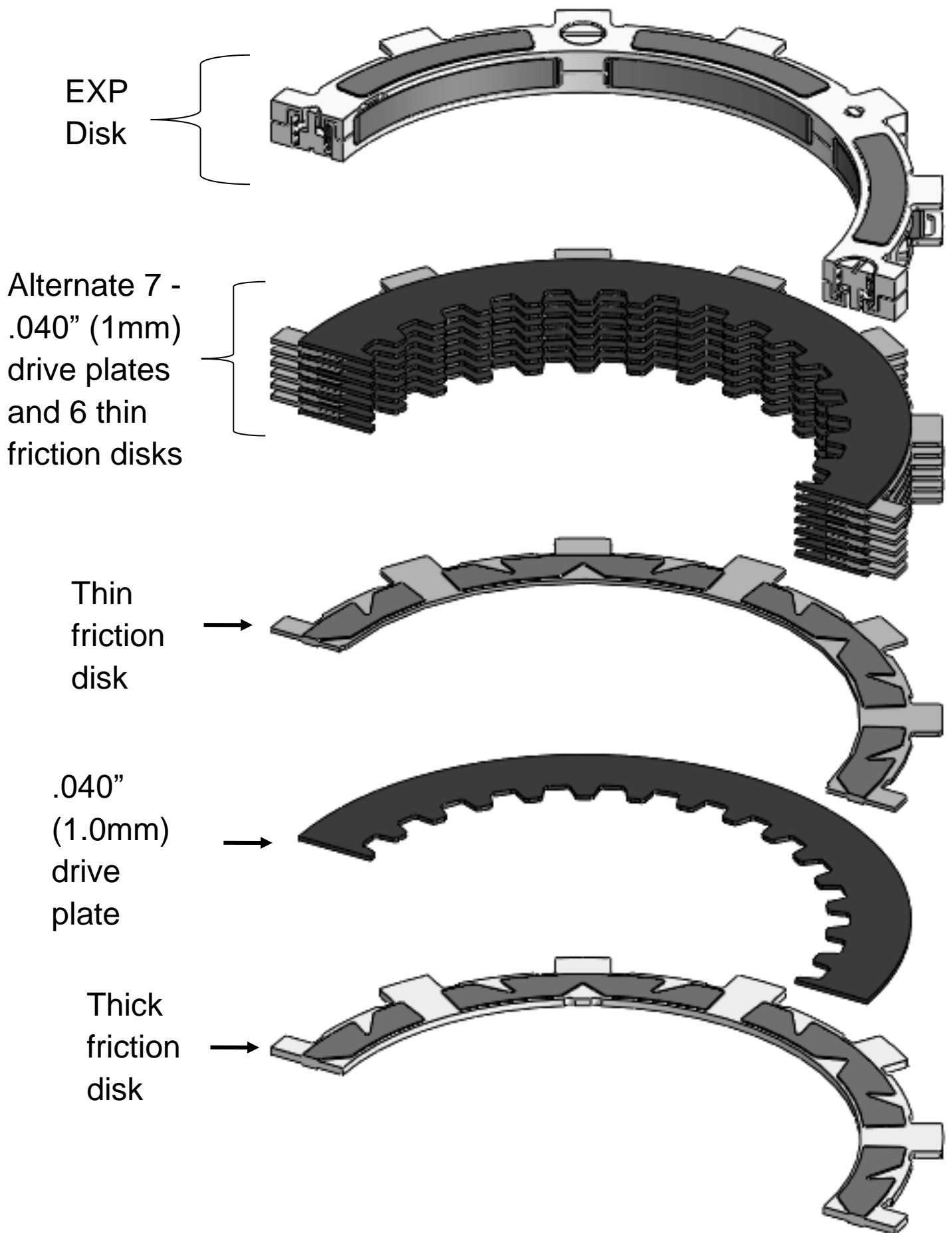



## Clutch cover spacing gasket

This model does not require a Rekluse clutch cover spacing gasket. Use your OE gasket when installing the cover.

### CAUTION

*When installing the clutch cover, tighten the cover bolts in a star pattern in small increments. The clutch cover may crack or break if too much torque is applied all at once or if bolts are tightened in a different pattern.*

## Pressure plate springs

Model	Pressure plate springs used
YFZ 450R	6 Purple Rekluse Springs

### NOTICE

*If you have two different color pressure plate springs in your kit, be sure to alternate them during installation.*

## EXP tuning options

Included are three spring options to tune the engagement RPM of the EXP friction disk. The EXP friction disk comes set with the recommended “Medium” setting from Rekluse.

The following chart shows the spring configuration. In addition, adjust the engine idle speed to match your engagement setting. This is important and affects the overall feel of how the EXP friction disk engages.

To prevent free-wheeling and maximize engine braking, set the idle so there is a slight amount of drag while the bike is idling in gear and warmed up. The idle should not be so high that the bike moves forward while in gear with the throttle closed. However, with a small opening of the throttle, the bike should move forward.

## YFZ 450R

Engagement setting	Spring configuration
<b>Low</b>	3 Red & 3 Blue
<b>Medium</b>	6 Blue
<b>High</b>	3 Gold & 3 Blue

## Changing the springs

1. Using a flat-blade screwdriver, push the  $\frac{1}{4}$  turn pin in far enough to clear the opposite side of the EXP to unlock the pin.
2. With the pin still pushed past the base, turn  $90^\circ$  to remove the pin and spring.
3. Remove the remaining 2 pins and springs from the same side of the EXP base.
4. Drop a new spring into the spring slot on the base, then add the  $\frac{1}{4}$  turn pin.
5. Push the turn pin in far enough to clear the base, then turn  $90^\circ$  and release the pin. The pin should sit almost flush with the EXP base.
6. Flip the EXP friction disk over, and repeat on the other side depending on engagement preference.

### NOTICE

*When installing two different color of springs, use only 1 color for each side. To maintain even pressure while installing two different color spring sets, install one set of 3 on one side of the EXP, then flip the EXP over and install the remaining set of 3 on the other side.*

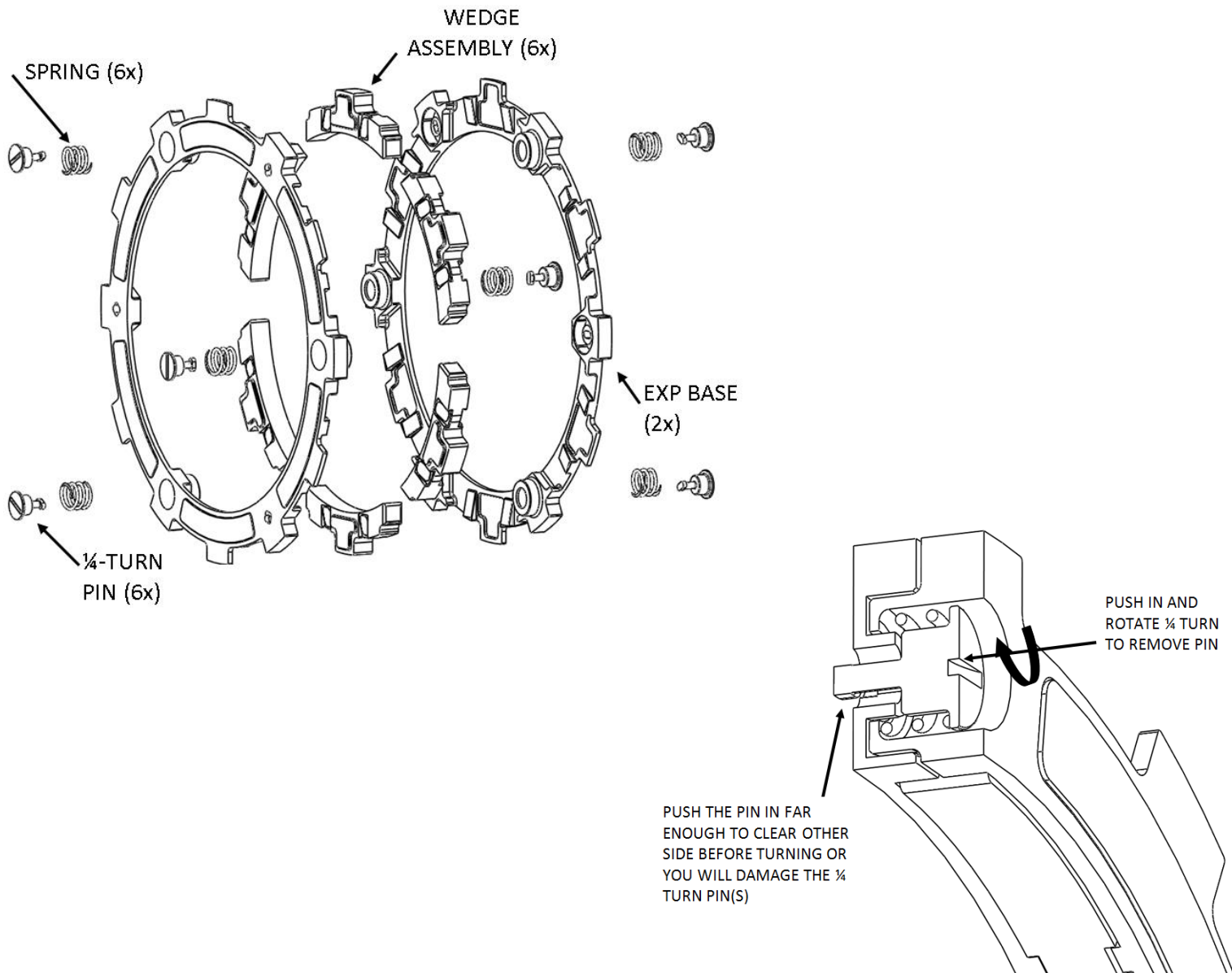

## Maintenance

A few preventive steps can help keep your new clutch performing at its best.

- Check your Free Play Gain before every ride, and adjust if necessary.
- Change the oil regularly according to the bike manufacturer's recommendations. Clutch function and longevity depends on oil quality.
- Inspect all of your clutch parts at regular intervals for signs of wear or excessive heat. If the friction disks look burned or glazed, or the drive plates are warped, replace the entire clutch pack to restore performance.
- Repeat break-in procedure anytime friction disks or EXP bases or wedges are replaced.
- Always soak friction disks or EXP bases in oil for at least 5 minutes before installing.

# Troubleshooting

If you find yourself adjusting Free Play Gain or drag, the clutch disks might be worn. Excessive heat or clutch slip can cause premature clutch failure as well. Once extreme temperatures are reached, irreversible damage may occur.

Measure your clutch pack. If the clutch pack is outside of the nominal clutch height, measure the friction disks and EXP disk for wear. Replace as necessary.

- Nominal clutch pack height (Measure steel drive plates, friction disks, and EXP together) = **1.336" (33.93 mm) ± .020" (.508 mm)**
- Rekluse thin friction disk minimum allowable thickness = **0.067" (1.70 mm)**
- EXP disk minimum allowable thickness = **0.416" (10.57 mm)**

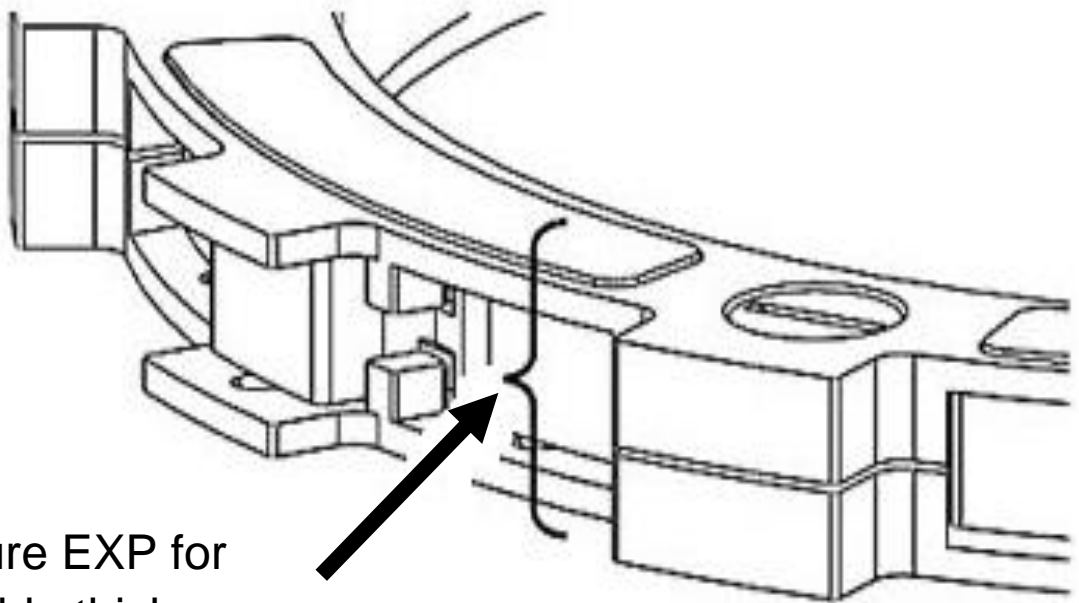

- Measure EXP for allowable thickness **0.416" (10.57mm)**

## Need additional help?

Contact Technical Support or visit our website for questions related to product installation, tuning, or performance issues.

### Website:

[www.rekluse.com/support](http://www.rekluse.com/support)

### Email:

[customerservice@rekluse.com](mailto:customerservice@rekluse.com)

### Phone:

(208) 426-0659