



INSTALLATION GUIDE

Harley-Davidson
Sportster

Table of Contents

OVERVIEW	3
INSTALLATION TIPS	3
TOOLS.....	4
INCLUDED PARTS	5
BEFORE YOU BEGIN.....	5
DISASSEMBLE CLUTCH.....	5
ASSEMBLE THE CLUTCH BASKET	15
INSTALL THE CLUTCH PACK	17
INSTALL THE PRESSURE PLATE.....	20
FINISH INSTALLATION	23
RESET THE LEVER FREE PLAY.....	27
BREAK IN THE NEW CLUTCH.....	27
MAINTENANCE.....	28
Disk inspection examples.....	29
TROUBLESHOOTING	30
Performance issues.....	30
Clutch Drag	30
Clutch Slip	30
NEED ADDITIONAL HELP?.....	30

OVERVIEW

This kit replaces the OE (Original Equipment) or “stock” clutch pack.

- This kit will replace all the OE clutch pack, pressure plate, the pressure plate springs and screws, and the inner clutch hub.

INSTALLATION TIPS

- Read the separate included Safety Information document before operating the vehicle with the product installed.
- Read this entire document before performing any steps.
- If you install this product for a customer or another person, instruct them to read the **Safety Information** document and the **Installation and User Guide** before operating the bike with the product.
- Videos related to this product can be viewed online at www.rekluse.com/support/videos.
- Protect eyes and skin – wear safety glasses and work gloves. Work in a well ventilated area.
- Use the torque values listed in the instructions. Otherwise, use the torque specifications found in your OE service manual.
- Visit www.rekluse.com/support for a full parts fiche illustration and part numbers.
- For optimal clutch performance Rekluse recommends using fresh, clean oil that **meets JASO-MA** oil rating requirements. Rekluse offers Factory Formulated Oil™ developed specifically for Rekluse products. Rekluse Factory Formulated Oil is a perfect complement to any OEM or aftermarket wet clutch. Visit www.rekluse.com to learn more.

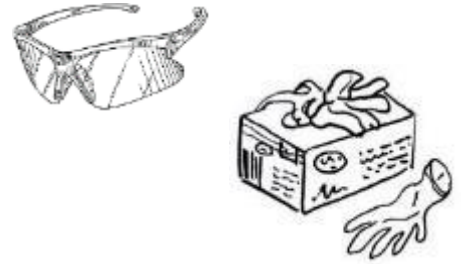

TOOLS

- 1/4" hex key
- 5/16" hex key
- 3/16" hex key
- 5 mm hex key
- 5/32" hex key
- 5/8" open-end wrench
- 9/16" open-end wrench
- 1/2" open-end wrench
- 7/8" open-end wrench
- Snap ring pliers
- Pliers
- 1 1/8" socket
- 1 3/16" socket
- Torque wrench
- Telescoping magnet
- Dental pick
- Shop/bench press
- Conventional oven
- T27 Torx bit
- Impact gun
- Flathead screwdriver

Additional tools available for purchase at a local dealership:

- Primary wedge tool
- Clutch spring removal tool

INCLUDED PARTS

Refer to the included **Parts Fiche** for a detail of the components.

Visit www.rekluse.com/support for a full parts fiche illustration and part numbers.

BEFORE YOU BEGIN

- Rekluse recommends replacing the chaincase cover gasket when installing this product.
- The OE basket bearing may need to be replaced if it shows signs of excessive wear.

DISASSEMBLE CLUTCH

1. Fully collapse the in-line cable adjuster, so that the clutch lever becomes very loose at the perch. This removes the tension on the clutch cable during disassembly and installation.

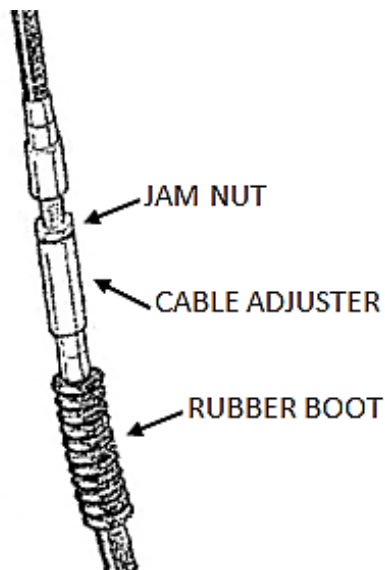

2. Soak the TorqDrive[®] friction disks in engine oil for 5 minutes.

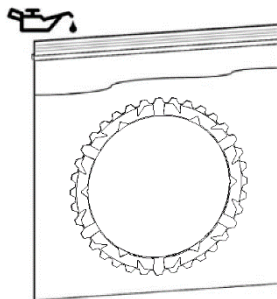

3. Stand the bike up on a suitable bike stand or lift.



4. On the primary chain case, use a 5/8" wrench to remove the oil drain plug, then drain the oil into a suitable container.

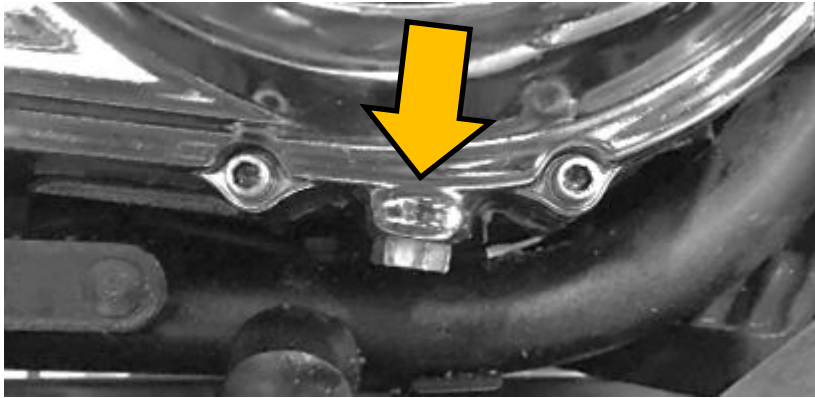

5. Loosen the chain tensioner lock nut, then turn the chain tensioner adjustment bolt **counterclockwise** until it spins freely.



6. Shift the bike into 5th gear, then remove the shift lever off its shaft and set it aside.

7. Remove any footboards that block the primary case and set them aside.

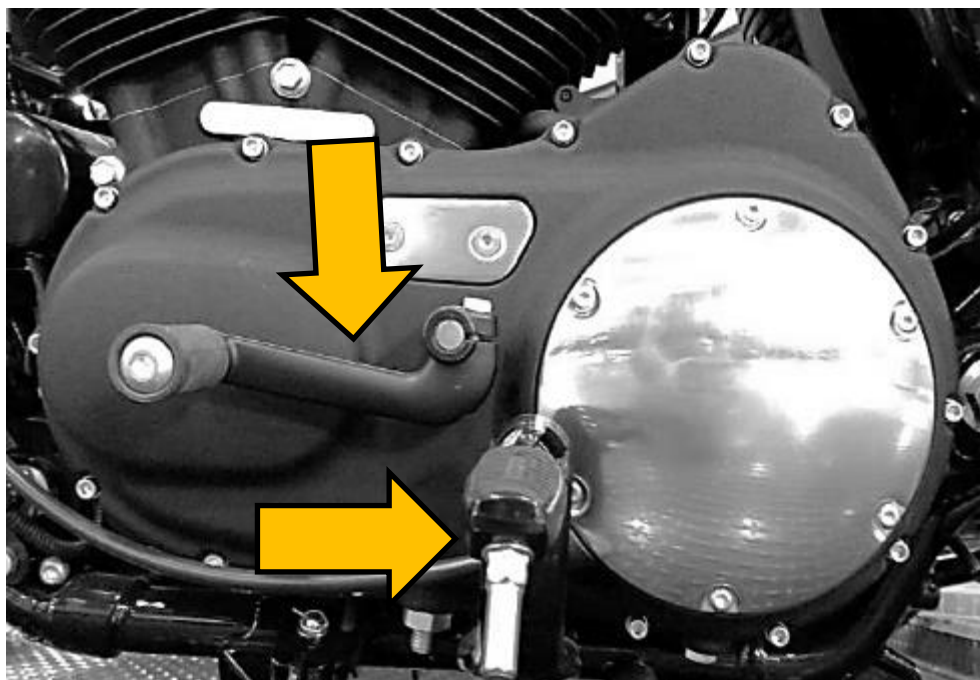

8. Remove the derby cover and the O-ring gasket.

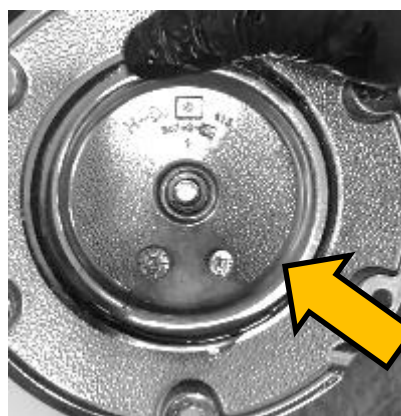
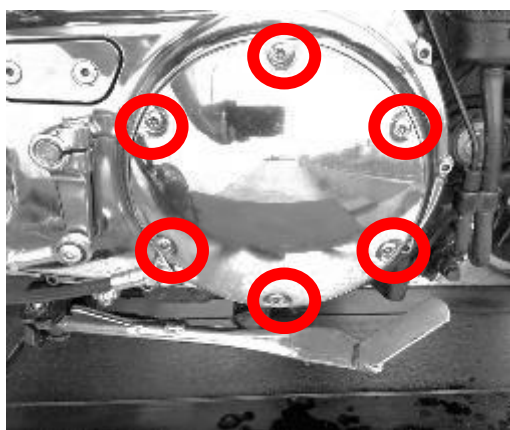

9. Remove the spring and the jam nut from the actuating mechanism. Set these aside.

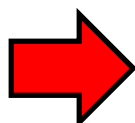
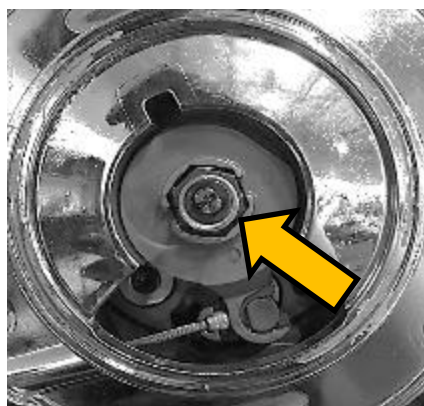

10. Use a flat blade screwdriver to turn the threaded stud **clockwise** to remove the nut. Set it aside.

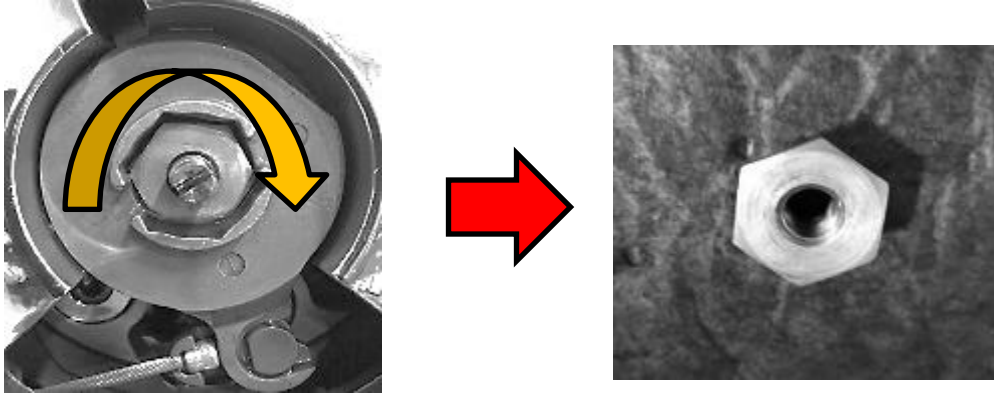

11. Clear a space below the primary gasket cover to set the cover once it is removed. Remove the primary case cover and the cover gasket.

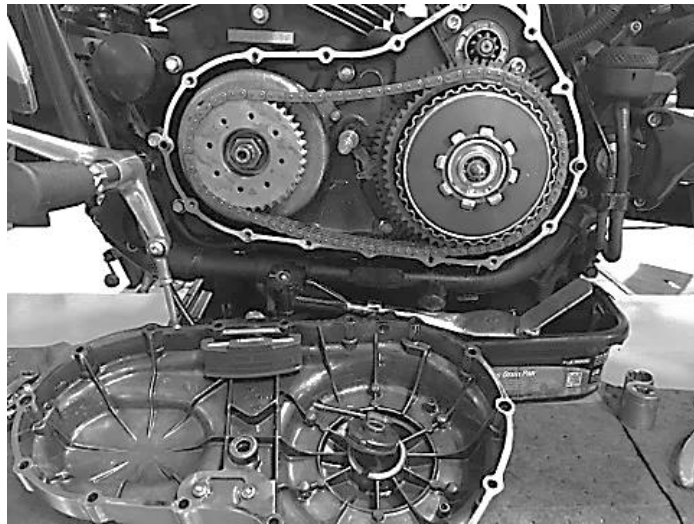

Note: *The attached clutch cable limits where you can set the primary cover when it is removed.*

12. Hand thread the clutch spring compressor tool onto the throw-out rod.



13. Use a 9/16" open-ended wrench to hold the clutch tool shaft in place. Slowly turn the compressor tool handle **clockwise** until the spring is compressed enough to remove the snap ring.

⚠ CAUTION

The spring is loaded. Wear eye protection.

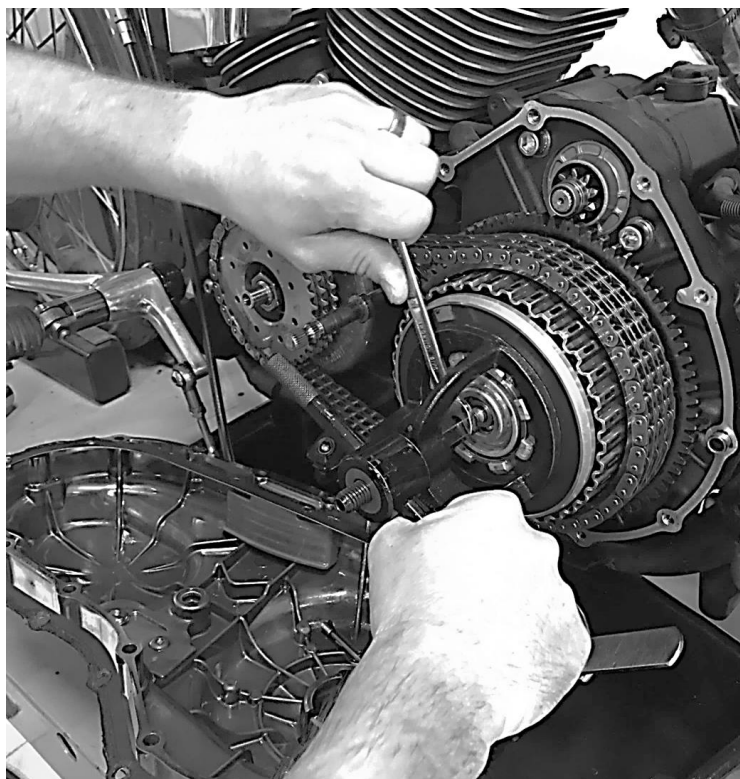

14. Use a pair of pliers to remove and discard the clutch spring retaining ring.

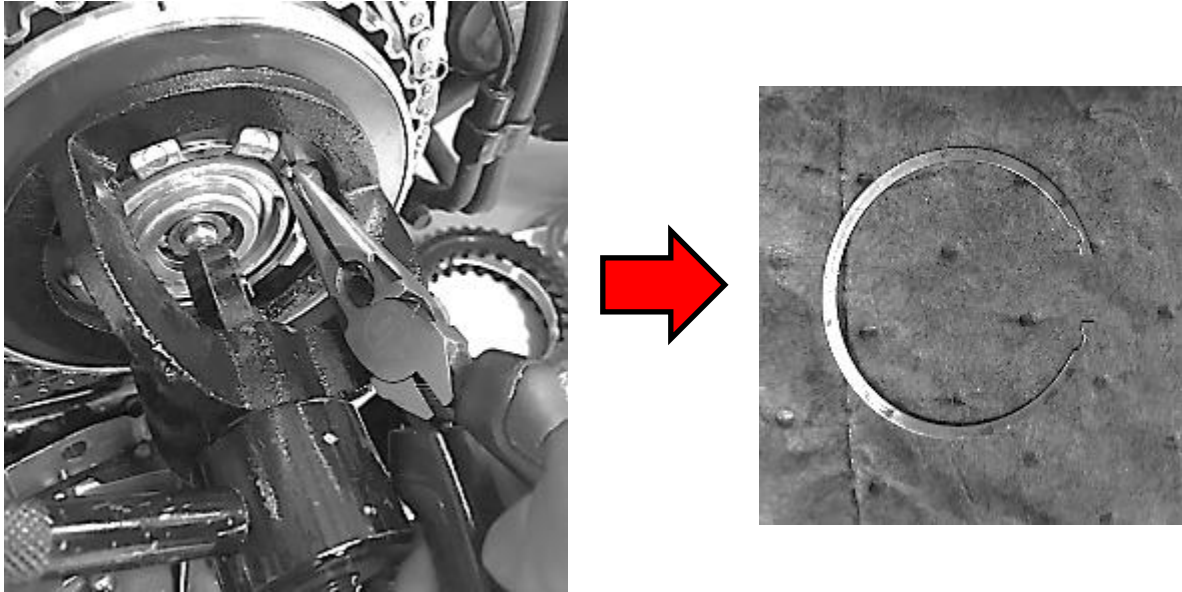

15. Remove the OE clutch Belleville spring and pressure plate and set them on a workbench.

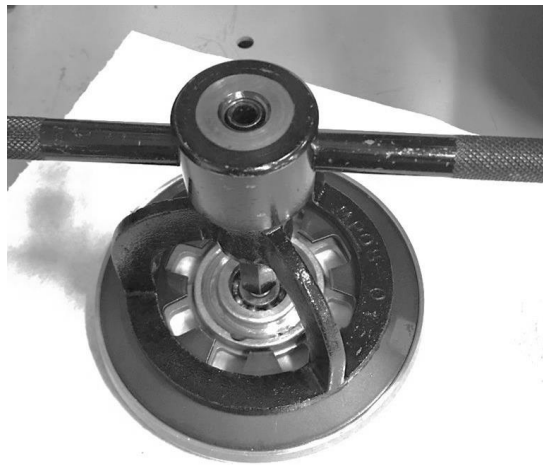

16. Use a 9/16" open-ended wrench to hold the clutch tool shaft in place. Slowly turn the clutch tool handle **counterclockwise** until it spins freely.

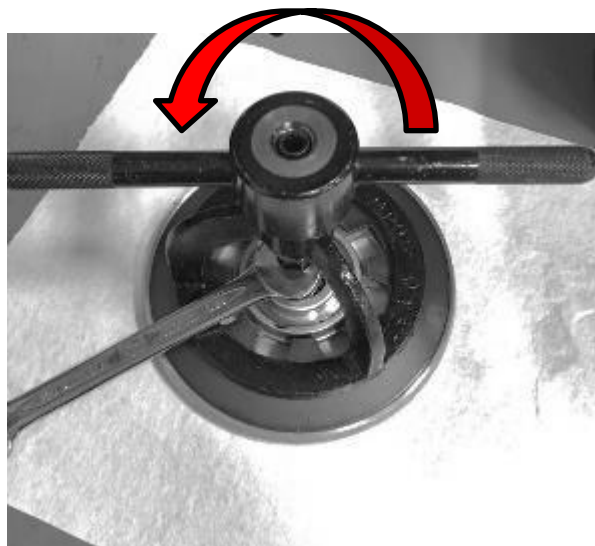

17. Unthread the clutch tool from the throw-out rod and remove it, then separate the Belleville spring from the pressure plate.



18. Use snap ring pliers to remove the snap ring from the throw-out assembly, then remove the throw-out assembly from the pressure plate.

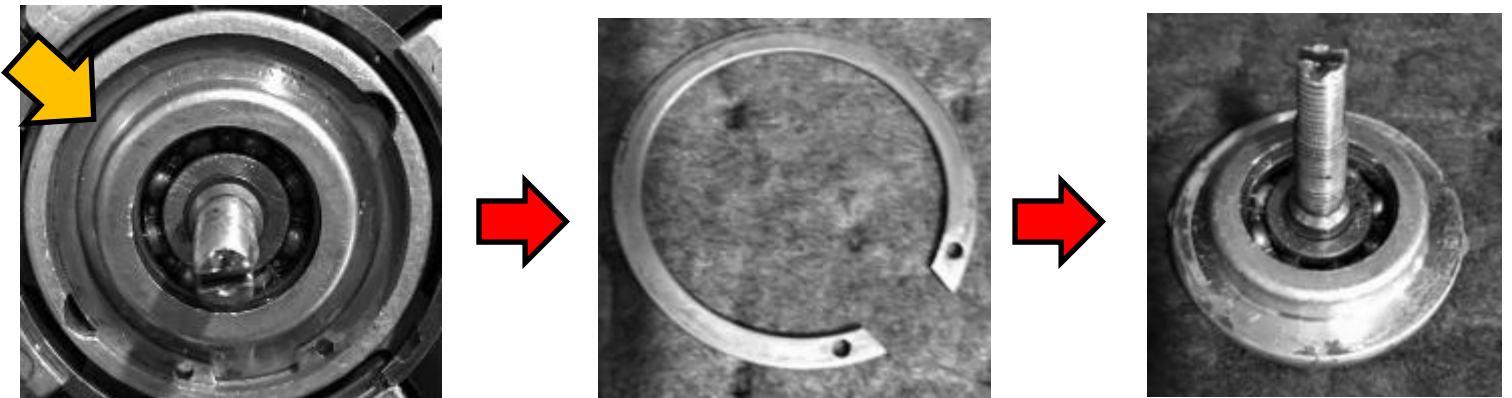

19. Remove the snap ring from the throw-out rod.

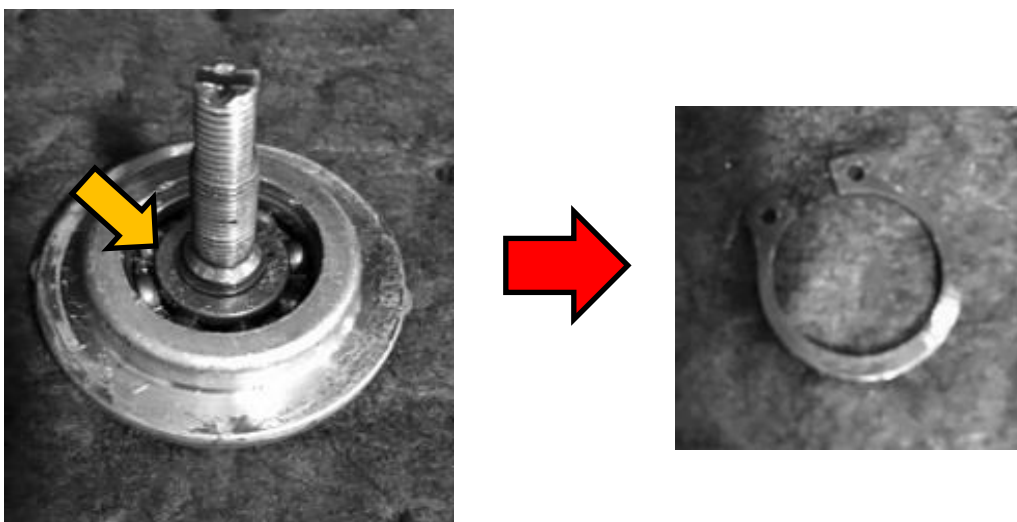

Note: Set aside the OE Belleville spring, OE pressure plate, and the OE snap rings. They will not be reused.

20. Using an impact gun and socket, remove the right-hand thread crankshaft nut by turning it **counterclockwise**. Set it aside.

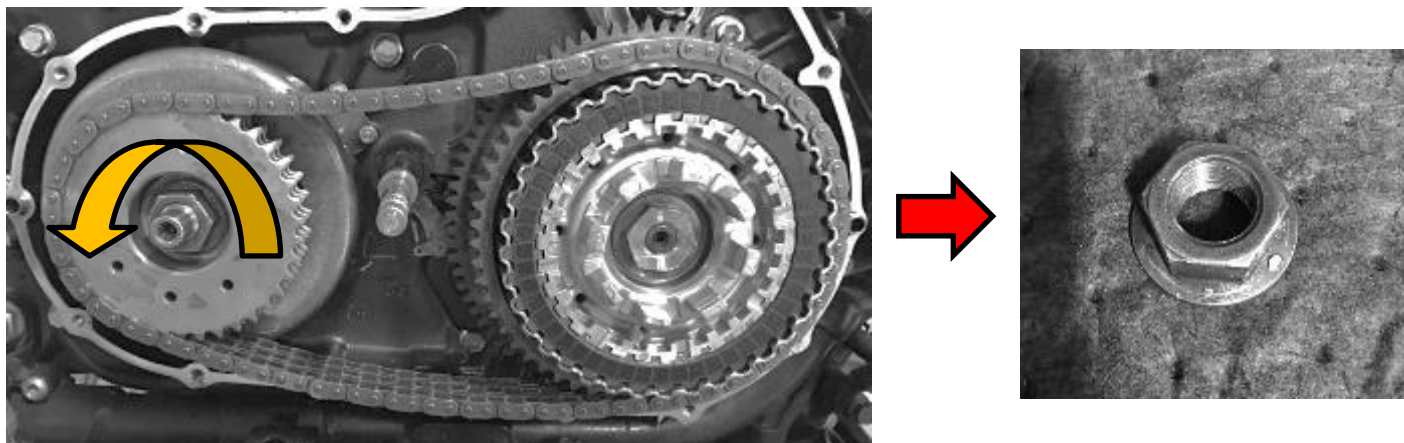

21. Remove the left-hand thread center clutch nut by turning it **clockwise** to remove it. Set it aside.

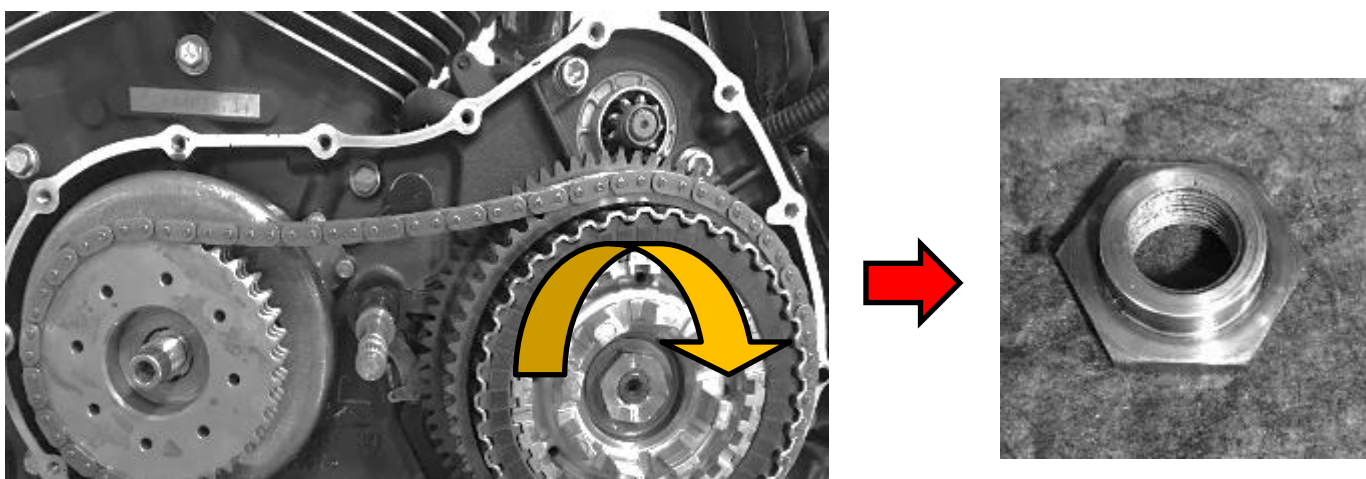

22. Remove the small Belleville washer that is located behind the center clutch nut.

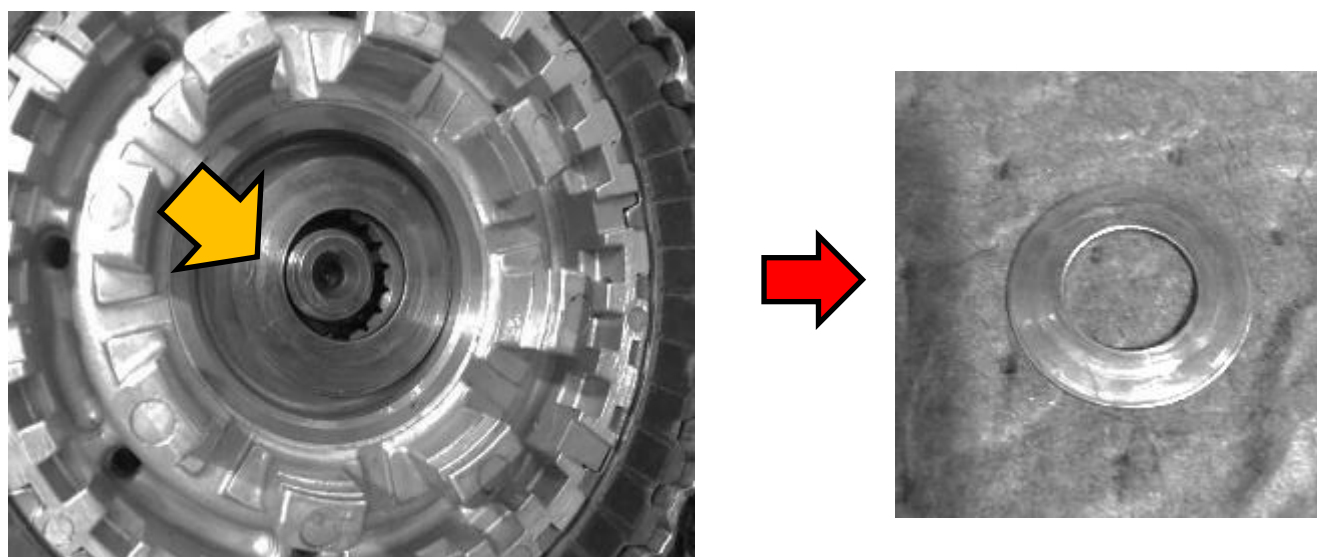

23. Remove the drive gear, clutch assembly, and chain simultaneously. **All three parts must be removed as one unit.**

- Do this by grasping the drive gear and clutch assembly in separate hands, then firmly slide them off their respective shafts. Carefully set this assembly on a workbench.
- If the drive gear is difficult to remove from the stator due to magnetism, use both hands to initially begin sliding it off of the shaft before removing it as a unit.

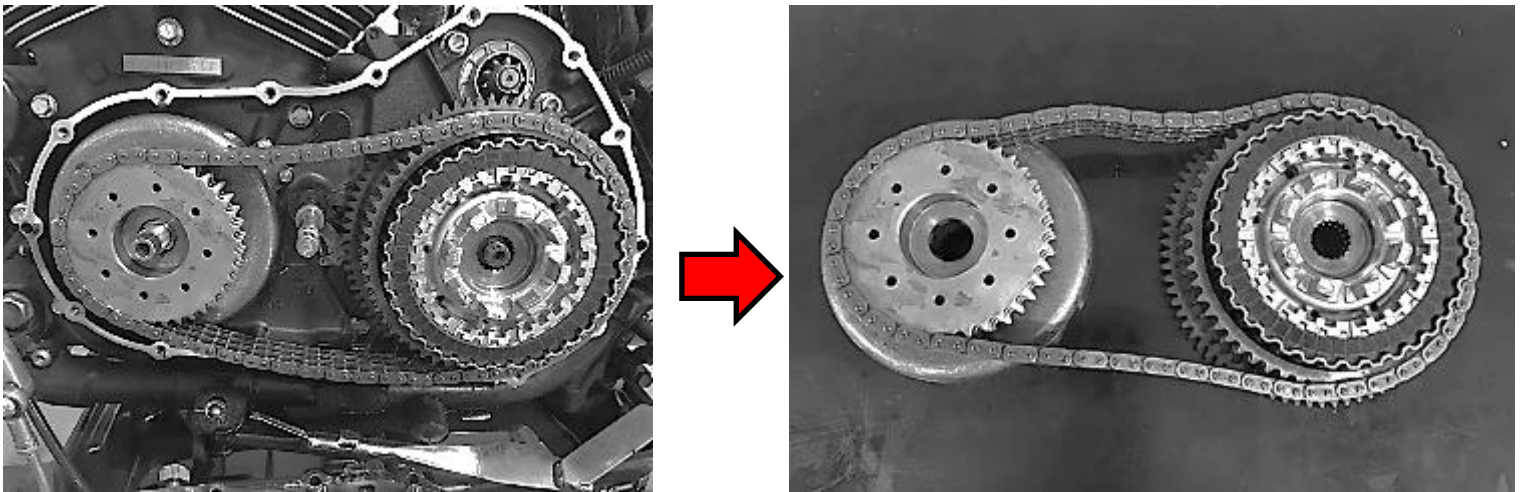

24. Separate the drive gear from the clutch assembly by sliding the chain off of each indexing gear and setting it aside.

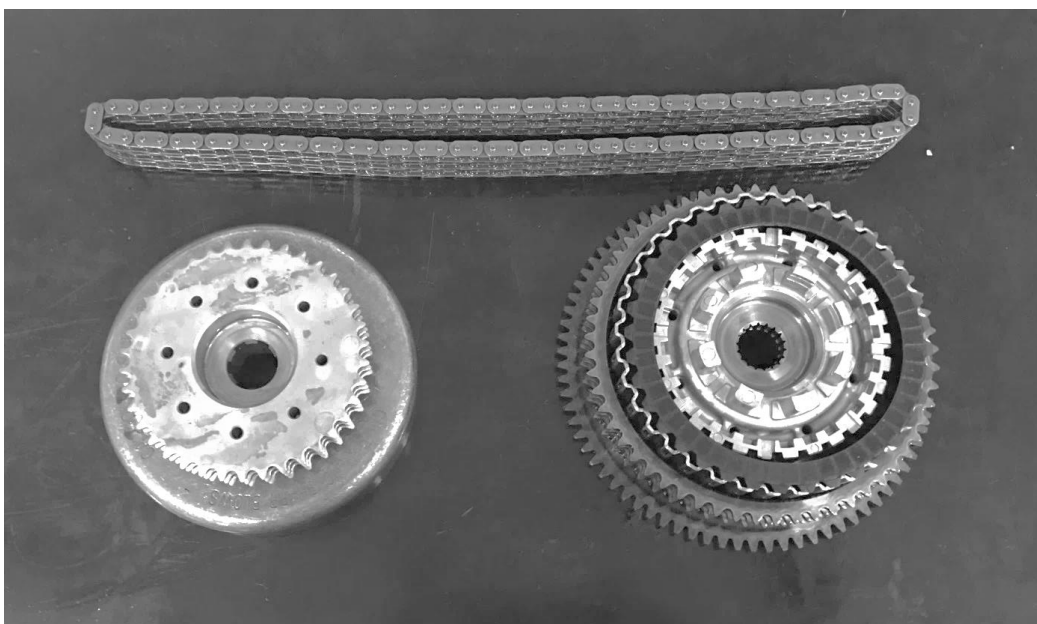

25. Remove the clutch pack from the clutch basket.

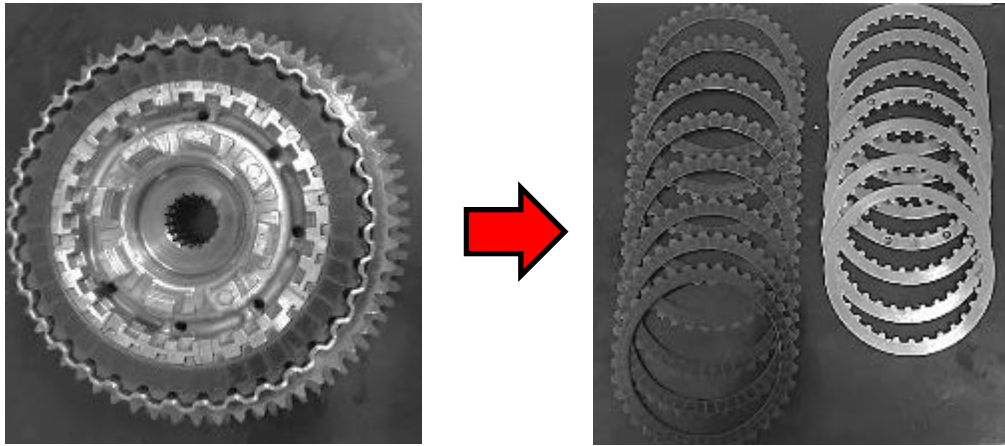

26. Flip the basket assembly over on a workbench, then use snap ring pliers to remove the center hub retaining ring. Set it aside.

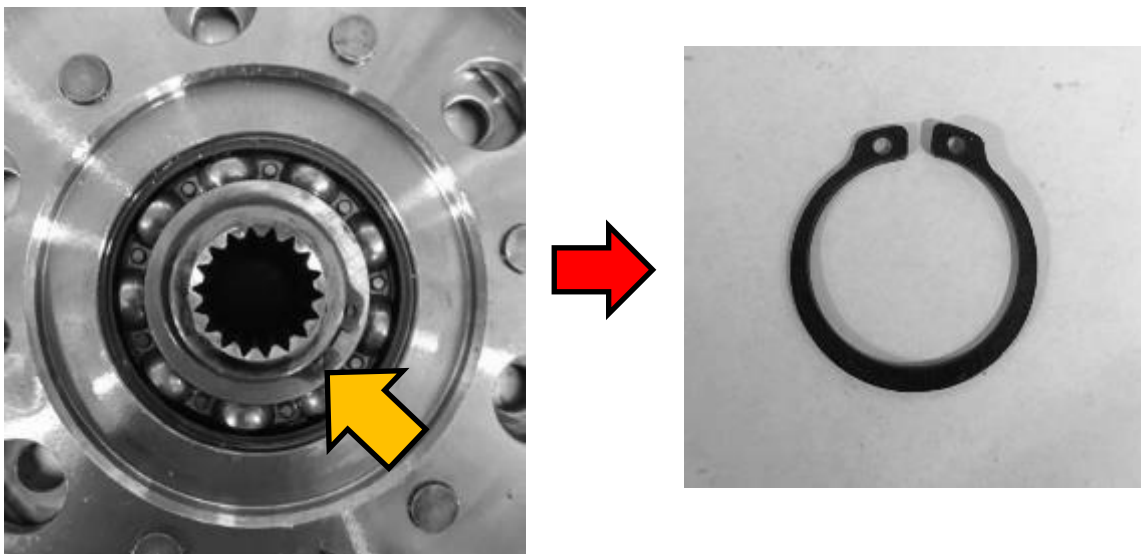

ASSEMBLE THE CLUTCH BASKET

1. Use a shop/bench press to press out the OE center hub from the clutch basket.

Note: Check the OE basket bearings for any signs of excessive wear or float. If the bearing appears worn, replace it with a new OE unit available at your local dealership.

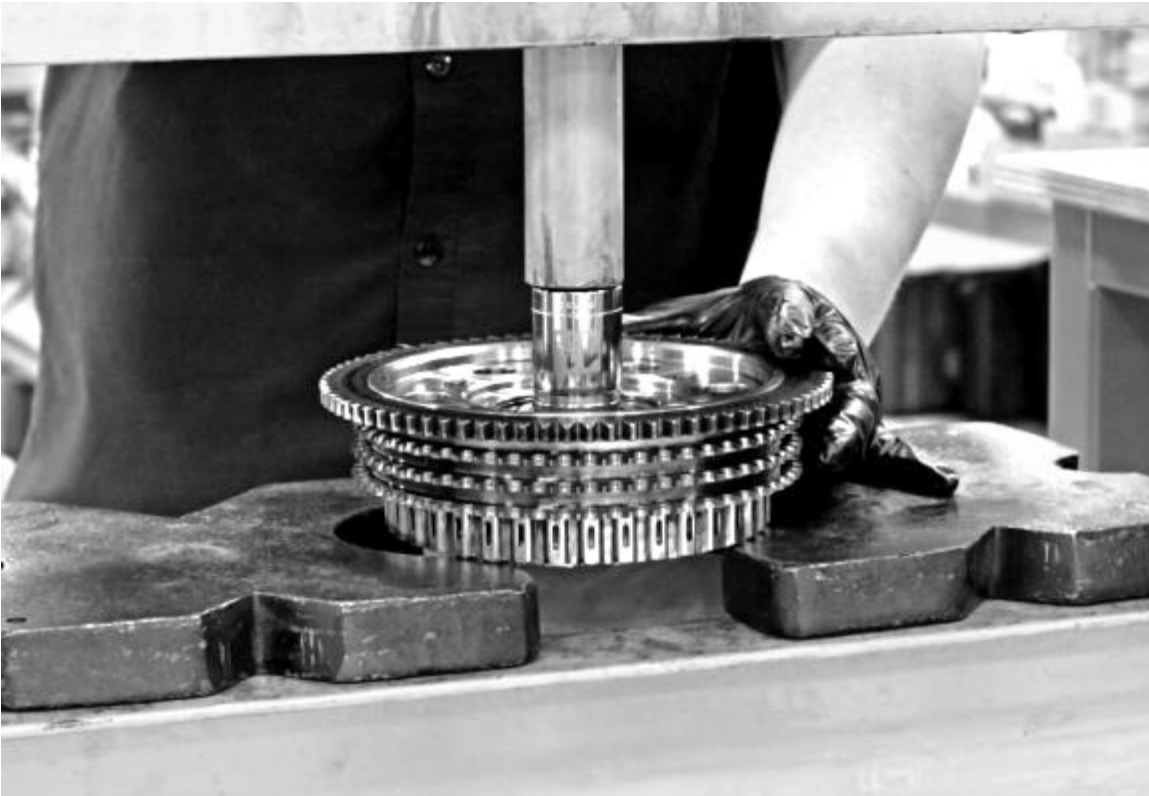

OE Basket

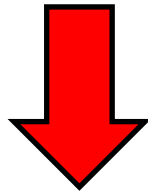

OE Center Hub



2. Preheat a conventional oven to 350°F (175°C), then place the OE basket in the oven for 15 minutes.



CAUTION

The basket will be **HOT!** Be sure to wear a protective covering on your hands when handling the basket.

3. Wearing a protective covering on your hands, remove the basket from the oven. Immediately install the Rekluse center hub into the OE basket. Use the press if needed to press the hub into the basket. Let the basket cool.

Note: *This thermal fit may allow for the Rekluse center hub to slide into the basket bearing without the need for a press.*

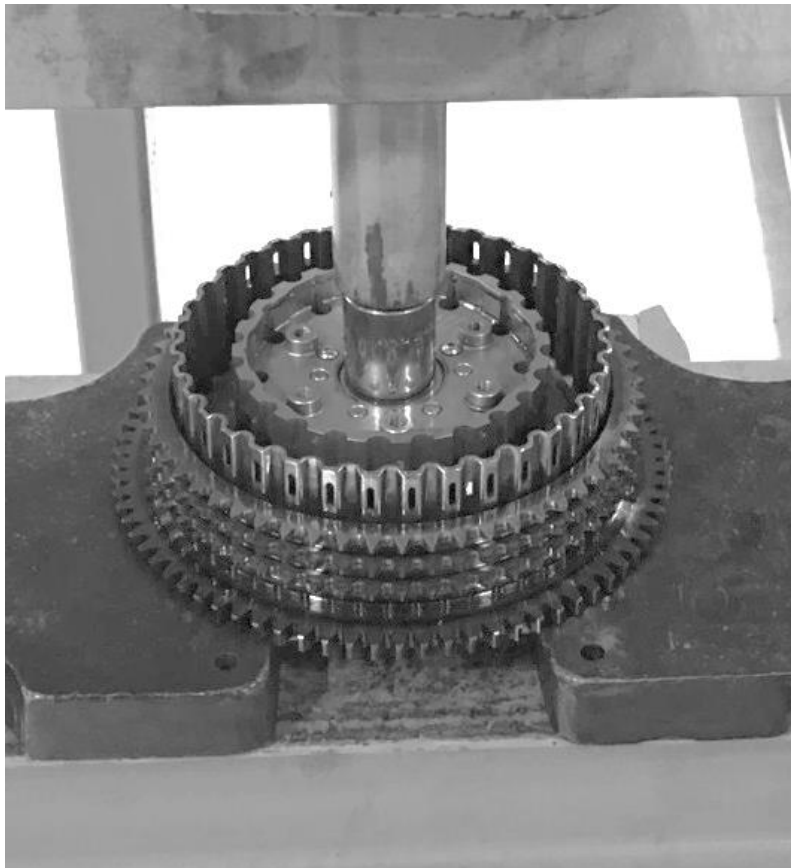

4. After the basket has cooled, flip the basket over and install the included **Rekluse 35 mm** retaining ring into the groove on the Rekluse center hub.

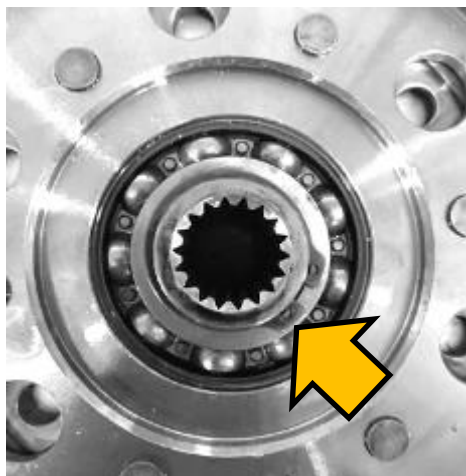

INSTALL THE CLUTCH PACK

1. Install a Rekluse steel drive plate 1st into the clutch basket
2. Continue to alternate Rekluse steel drive plates with TorqDrive[®] friction disks.

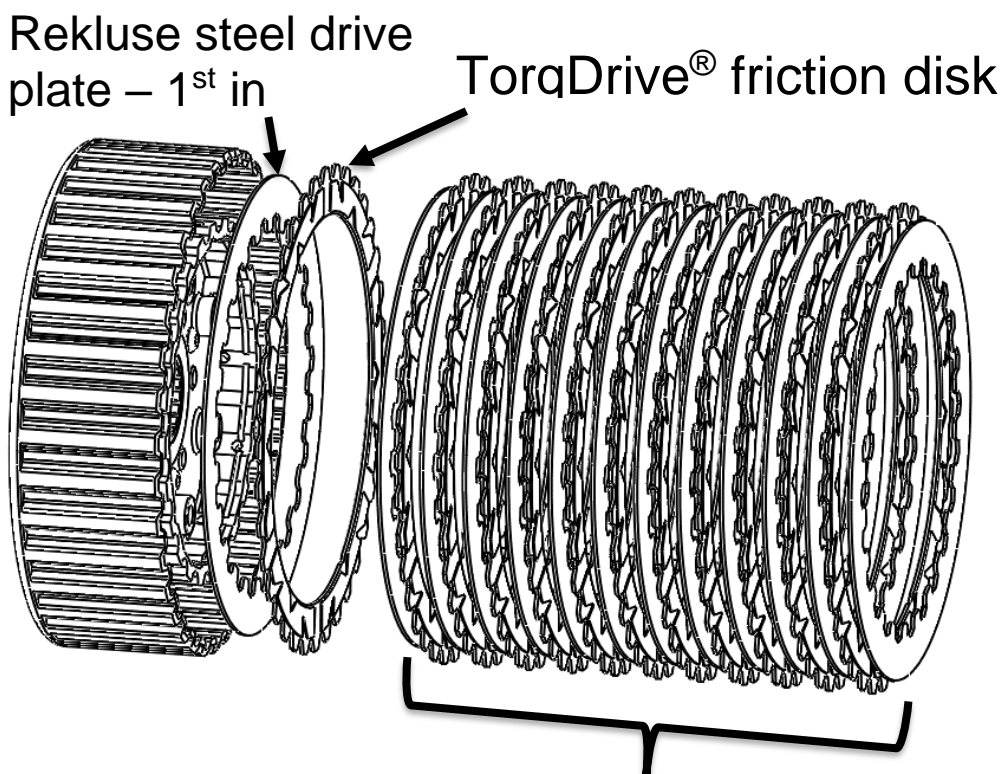

Total Clutch Pack

- 13 steel drive plates
- 12 TorqDrive[®] friction disks

Alternate Rekluse steel drive plates with TorqDrive[®] frictions

3. Re-index the chain onto the drive gear and clutch assembly.

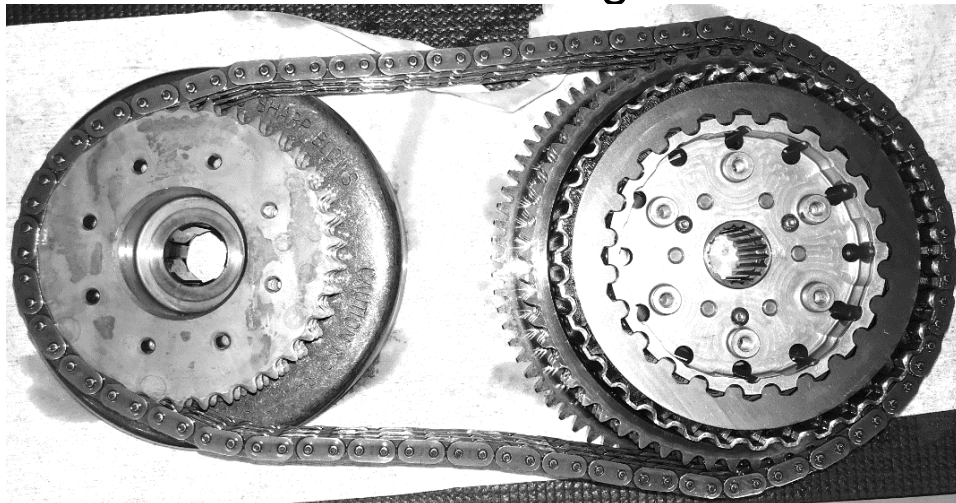

4. Install the drive gear, clutch assembly, and chain at the same time. Do this by grasping the drive gear and clutch assembly and firmly sliding them onto their respective shafts.

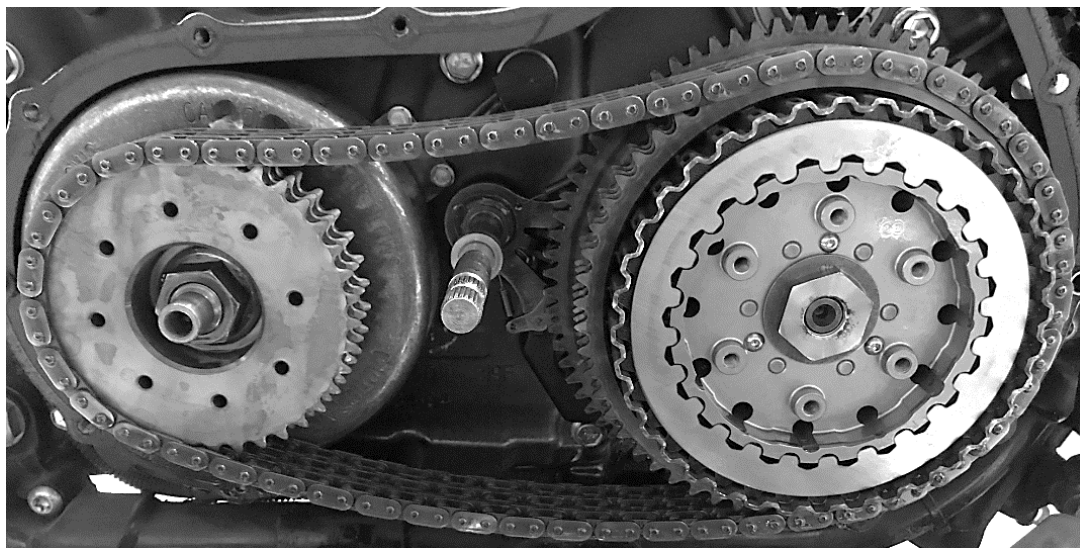

5. Place a primary wedge tool between the teeth of the drive gear and the clutch assembly gear. This will allow you to tighten the nuts.

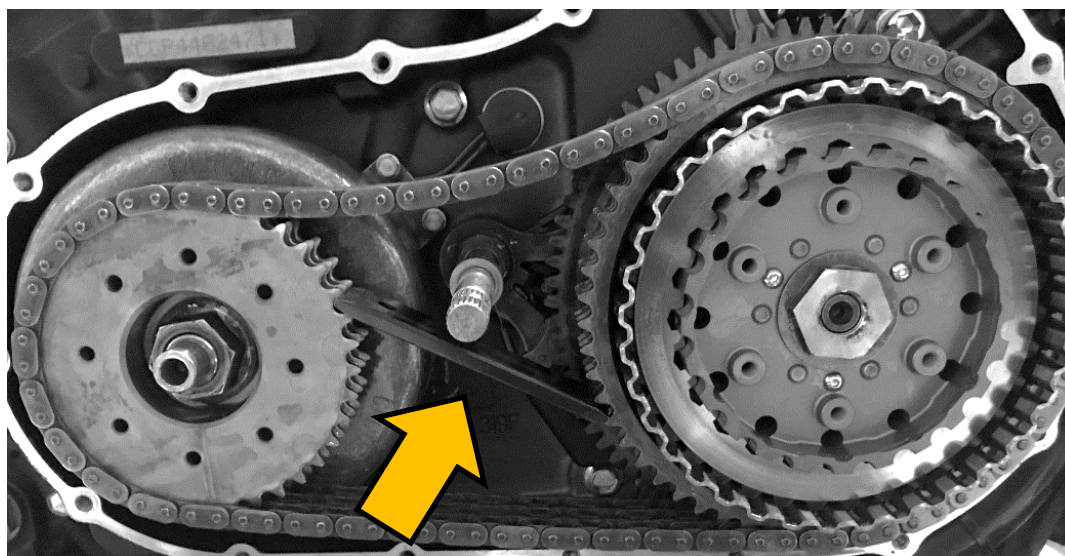

6. Apply 2 to 3 drops of the supplied Loctite 262 onto the threads of the crankshaft, then reinstall the OE crankshaft nut by turning it **clockwise**. Torque the nut to **240-260 ft-lb (325-353 N-m)** per OE specifications.

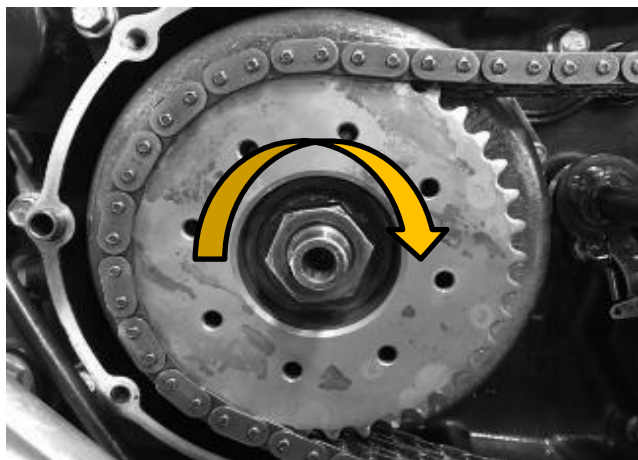
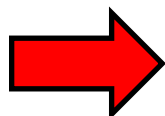

7. Apply 2 to 3 drops of Loctite 262 to the clutch shaft.

8. Reinstall the OE Belleville washer with the **cup-side facing up** on top of the OE center clutch nut.

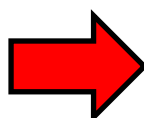
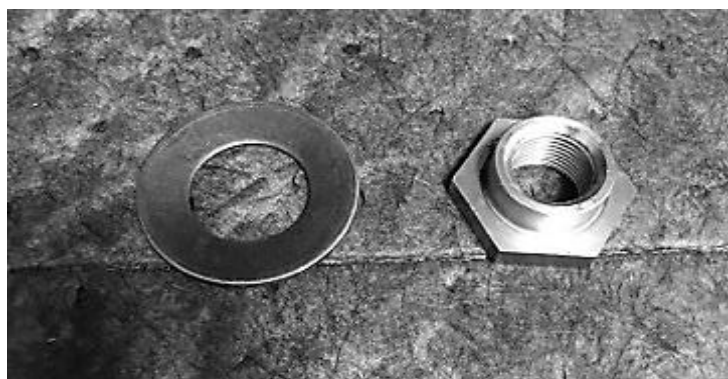

9. While keeping the OE Belleville washer on the nut, reinstall the center clutch nut onto the clutch shaft by turning it **counterclockwise**. Torque to **70 ft-lb (94 N-m)**. *Be sure to keep the washer indexed as you tighten the nut.*

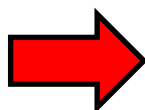

10. Remove the wedge tool.

INSTALL THE PRESSURE PLATE

1. Install the OE throw-out through the backside of the Rekluse pressure plate.

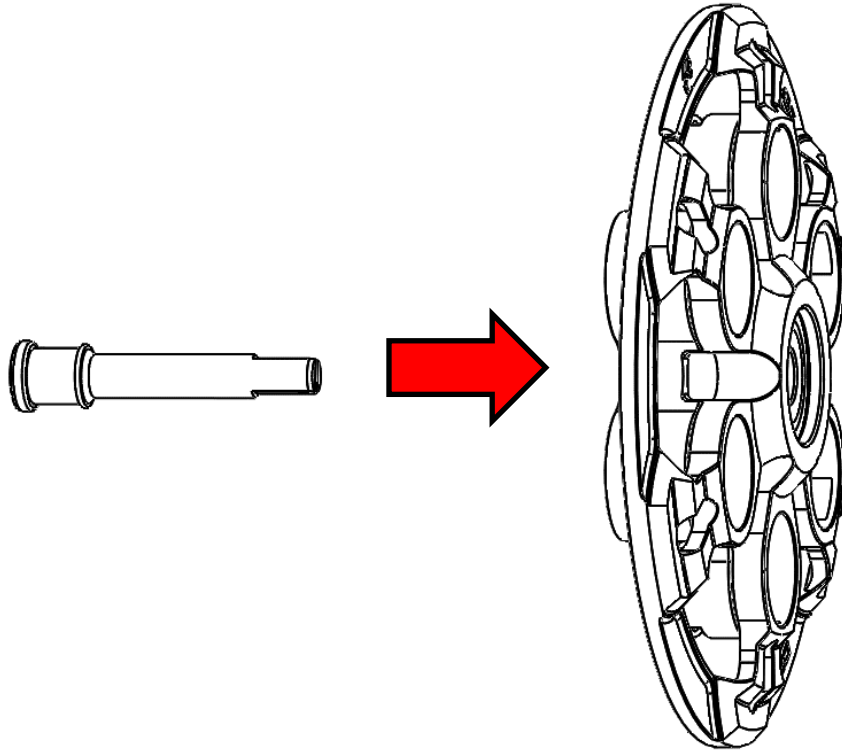

Note: 1993-2003 Sportster models:

Install the included throw-out spacer before installing the throw-out into the pressure plate.

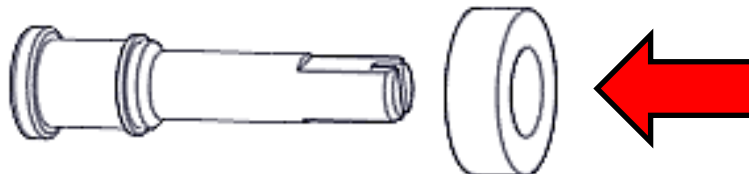

2. Install the pressure plate assembly onto the clutch assembly.

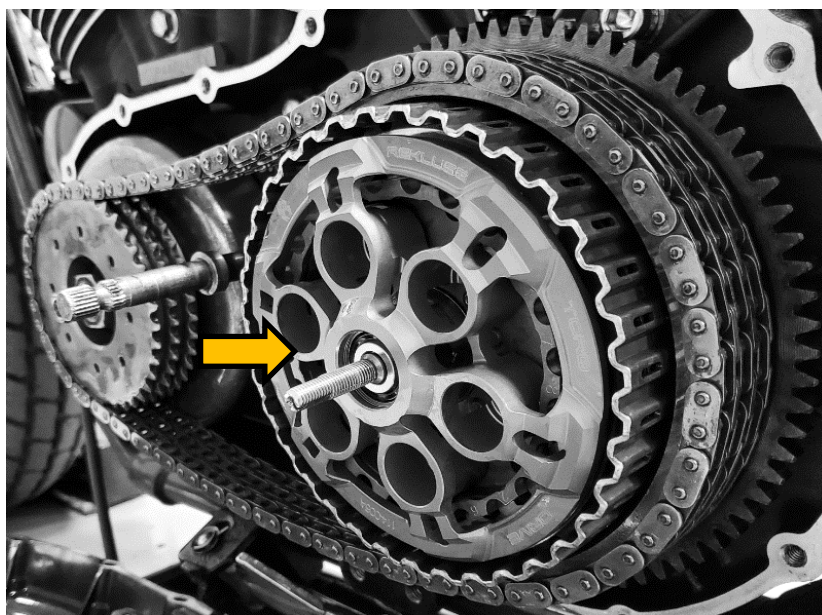

3. Install the Rekluse pressure plate springs, then install the screw sleeves. Install the pressure plate screws into the screw sleeves.
4. If installing springs of two different colors, alternate them for even pressure.

PRESSURE PLATE SPRING TUNING OPTIONS

Spring Color	Change in Lever Pull	Torque Capacity (lb.ft)	Change in Torque Capacity
3 Gold & 3 Silver	-23%	102	10%
6 Gold	-13%	111	20%
3 Gold & 3 Blue	1%	127	37%

Heavier and lighter springs are available from Rekluse for purchase

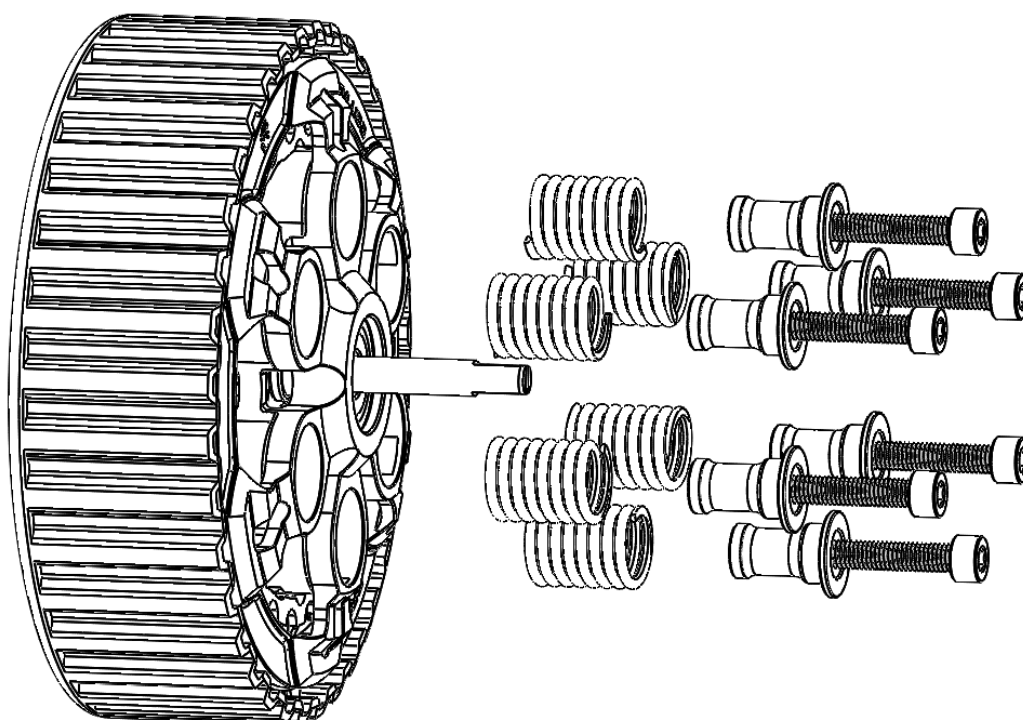

5. Torque the pressure plate bolts to **9 ft-lb (12 N-m)**.

6. Reinstall the OE primary case gasket. Inspect the OE gasket for signs of wear. If needed, replace it with a new OE gasket.

7. Check the inside of the primary case cover to make sure the clutch actuating mechanism is indexed properly into the key slot on the backside of the case.



8. Reinstall the OE primary case cover.

Note: *The easiest way to perform this step is by first aligning the shifter shaft with the primary case and sliding it on part-way. Then, lift the drive chain over the chain adjuster and slide the primary case on the rest of the way.*

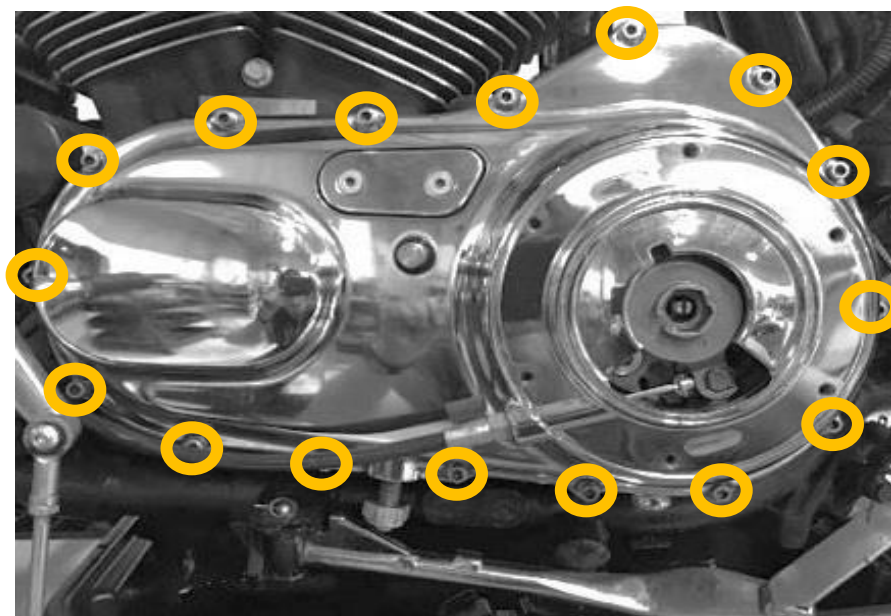

9. Torque the chaincase bolts to **80 in-lb (9 N-m)**.

FINISH INSTALLATION

1. Reinstall the OE threaded nut onto the OE threaded throw-out rod.

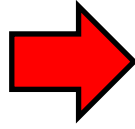
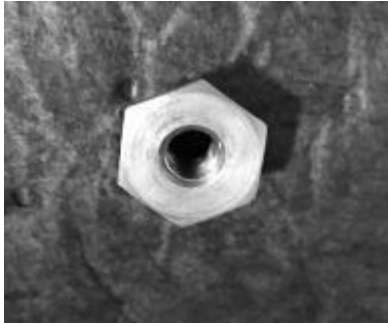

2. Turn the OE throw-out rod **counterclockwise** until you feel firm resistance. Now turn the throw-out rod clockwise $\frac{1}{4}$ turn.

Note: If the lock nut will not fully index, turn the throw-out rod clockwise slightly until it fully indexes between the throw-out rod and the slot in the clutch actuating mechanism

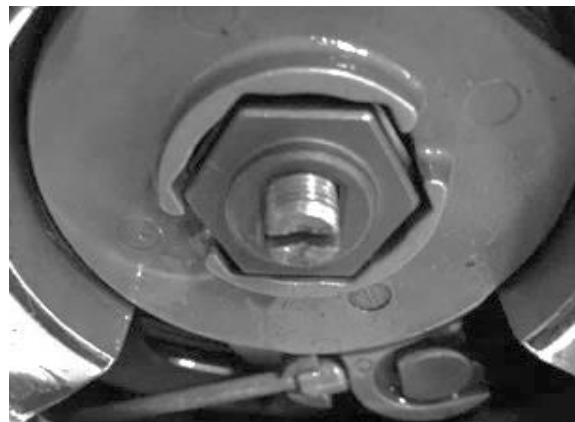
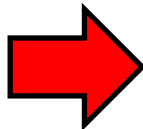
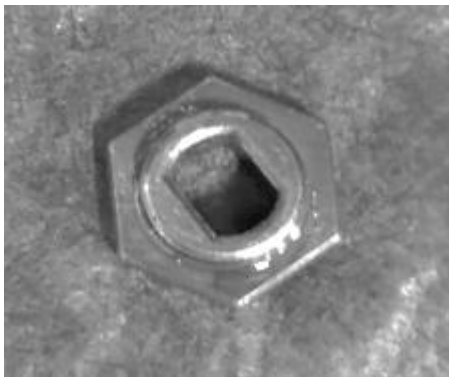

3. Reinstall the OE clutch actuating mechanism spring by pressing it onto the lock nut in the clutch actuating mechanism.

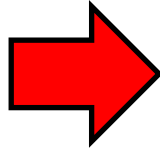

4. Reinstall the gasket for the OE derby cover, then install the derby cover. *Lightly applying grease to the o-ring can help hold it in place when installing the derby cover.*

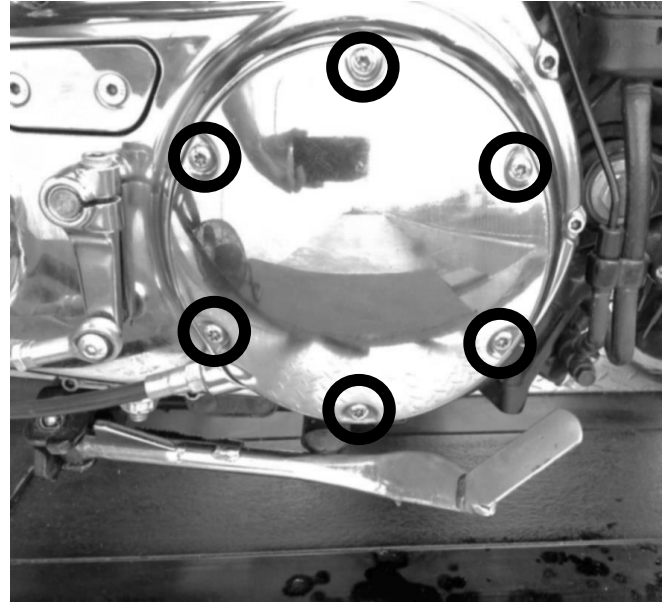
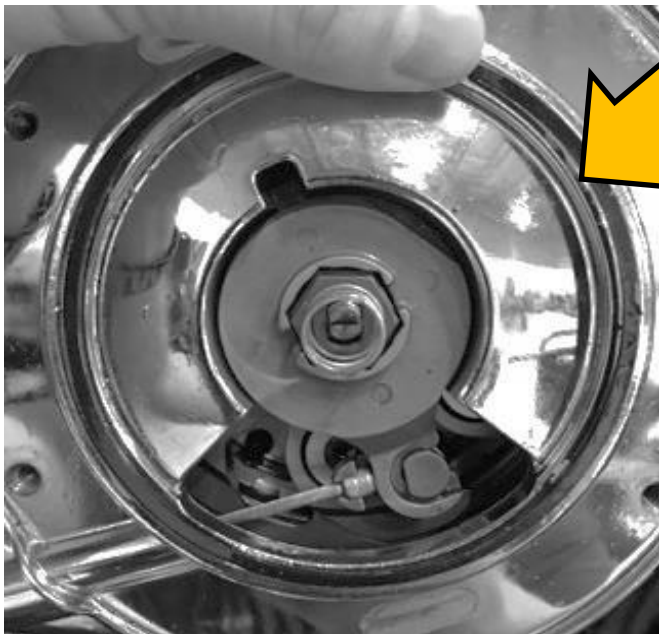

5. Torque the bolts to **40 in-lb (4.5 N-m)**.

6. Remove and set aside the OE chain inspection cover and gasket.



Inspection cover



Gasket

7. Verify that the lock nut on the chain tensioner is still loose. Then, turn the adjustment bolt on the chain tensioner **clockwise** until the drive chain has **3/8"** to **1/2"** of travel in it.

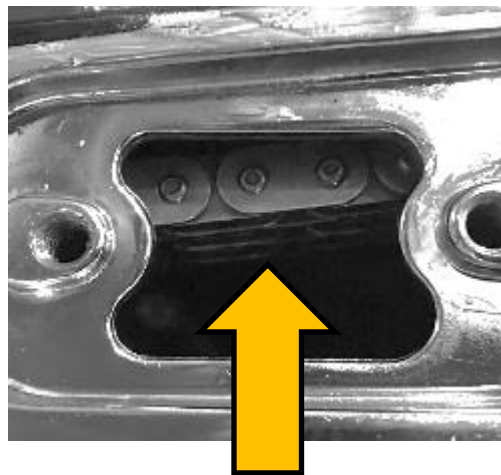
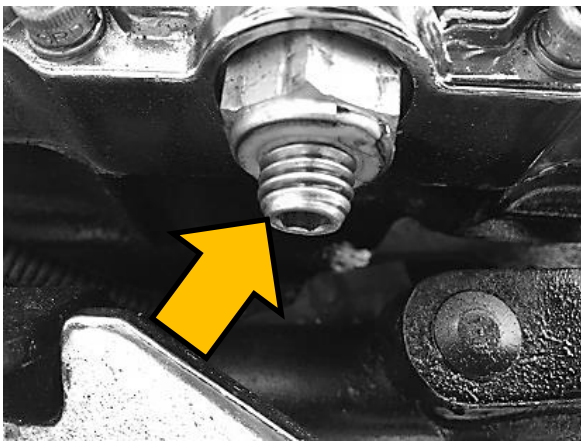

8. Taking care to keep the adjuster bolt from rotating, tighten the lock nut on the chain tensioner to **20 ft-lb (27 N-m)**.

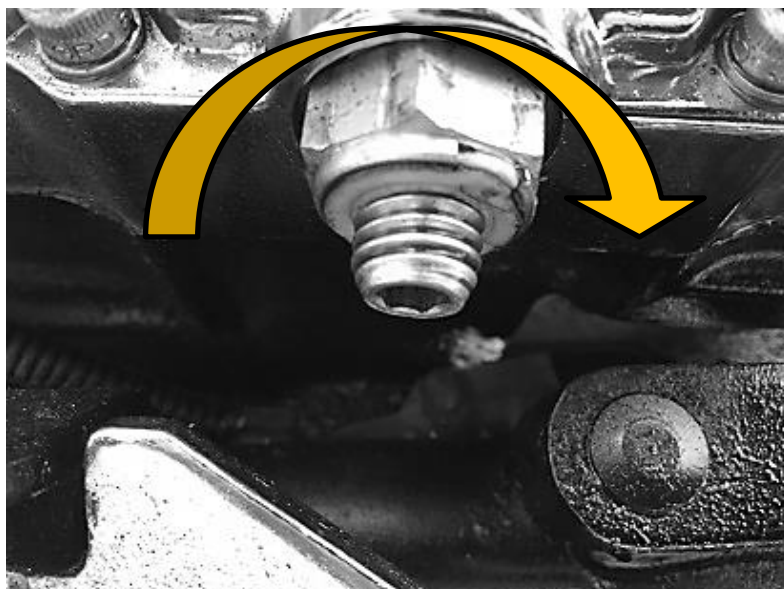

9. Install the oil drain plug. Torque to **14 ft-lb (19 N-m)**.

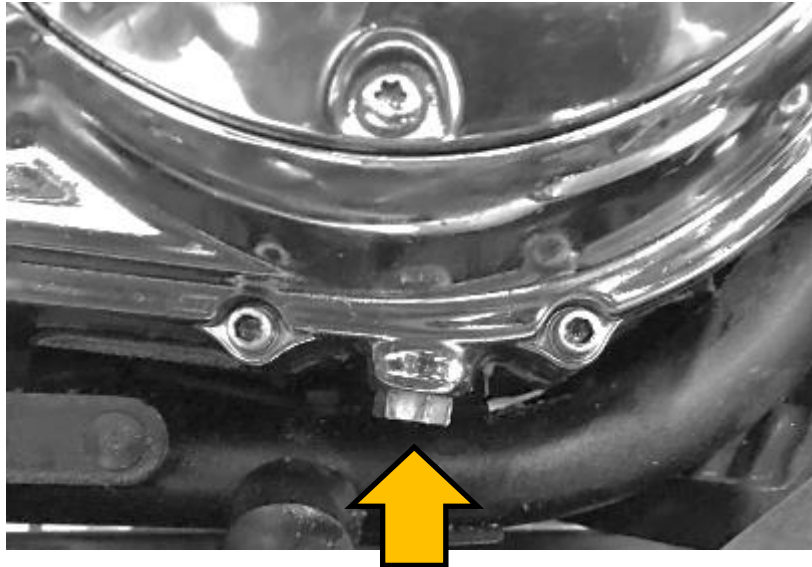

10. Insert a funnel into the inspection window and pour 1 quart of OE recommend oil into the primary chaincase.



11. Reinstall the OE chain inspection cover gasket and inspection cover. Torque the bolts to **40 in-lb (4.5 N-m)**.

12. Reinstall the shift lever onto its shaft followed by the footboards.

RESET THE LEVER FREE PLAY

“**Lever free play**” is essentially the “slack” in the clutch cable before it starts actuating the clutch. Applying a light finger pressure will take up this slack.

1. Expand the in-line adjuster until the cable slack is between 1/16” and 1/8” at the lever perch.

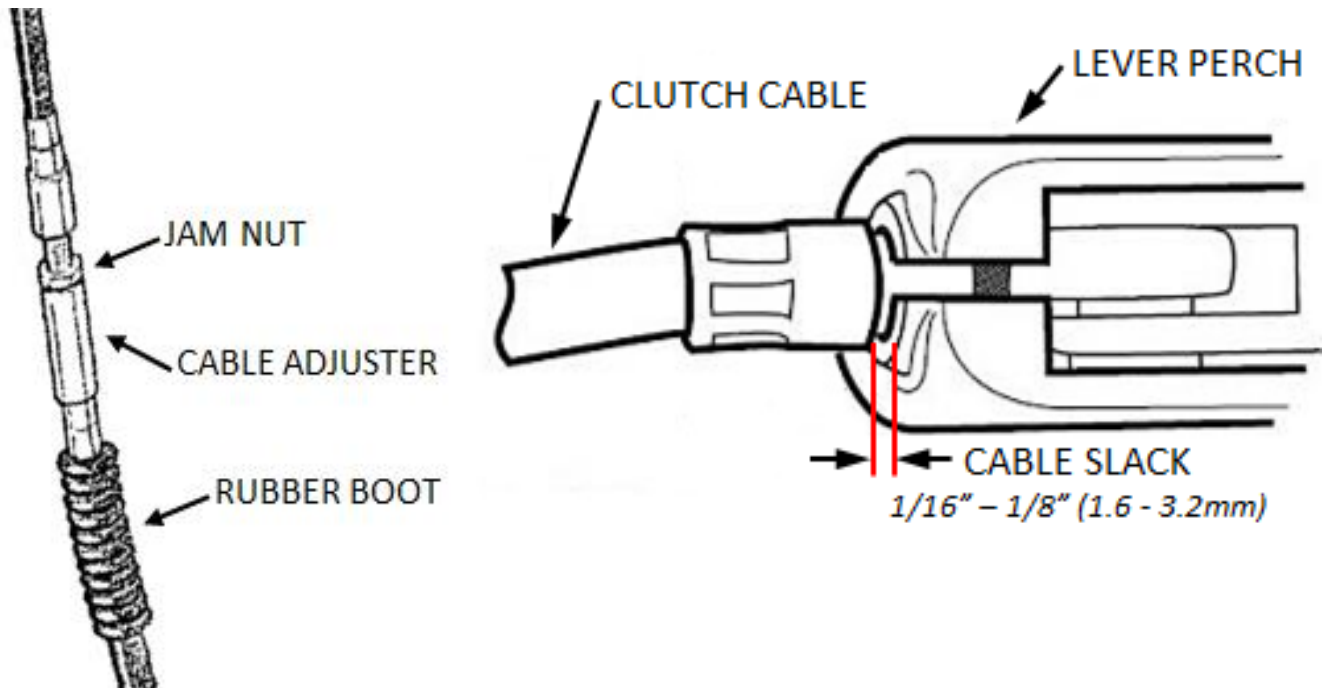

BREAK IN THE NEW CLUTCH

The clutch will break in within 100-200 miles of normal riding. Until break-in is complete, you may experience more clutch drag than normal.

- It is recommended to do an oil change after the first 1,000 miles to drain any excess clutch debris that occurred from the break-in.

MAINTENANCE

To keep your clutch performing at its best, perform regular maintenance on your bike and clutch.

- Keep up with regular oil changes according to the bike manufacturer's recommendations. Clutch performance and longevity depend on oil quality.
- Use oil recommended by the manufacturer of your bike.
- For optimal clutch performance, Rekluse recommends using fresh, clean oil that **meets JASO-MA** oil rating requirements.
- Inspect all your clutch parts for signs of wear or excessive heat and replace components as necessary. This includes your basket sleeves. Clutch wear is dependent on the rider's use.
- Repeat the break-in procedure anytime you replace the frictions disks. Always soak friction disks in oil for at least 5 minutes before installing.
- Replace friction disks if they measure below specifications or if the disks are glazed and/or burnt.
- Replace the drive plates if they show signs of excessive heat.

Disk inspection examples

When inspecting the clutch pack, the following pictures can be used as a reference. **These are best viewed in color by viewing this install document on www.rekluse.com/support.**

Drive Plates – If the clutch pack is getting high amounts of heat, purple, blue, or black color can be seen on the drive plate teeth. See pictures below. Not all drive plates look the same and may look different than pictured.



Normal Heat

High Heat
(Blue)

Excessive Heat
(Black)

Friction Disks – Due to the dark color of the friction material, the friction disks will appear almost black as soon as they are put in oil. During the inspection, look for glazing of the friction material. Glazing will appear shiny and feel like glass, even after the oil is cleaned from the friction disk. Not all friction disks look the same and may look different than pictured.



Normal Friction



Glazed Friction

TROUBLESHOOTING

Performance issues

If you find yourself constantly adjusting free play or adjusting for drag, the clutch disks might be worn. Excessive heat or clutch slip can cause premature clutch failure as well. Once extreme temperatures are reached, irreversible damage will occur.

- Inspect all of your clutch parts for signs of wear or excessive heat, and replace components as necessary. Clutch wear is dependent on the rider's use.
- Measuring the clutch pack can help determine if the components need replacing.

Clutch Drag:

If drag occurs only while the bike is cold, oil is the most likely cause. Be sure to warm up the bike before riding and/or racing. The use of lighter-weight oil can help to minimize cold drag.

Clutch Slip:

If clutch slip occurs, inspect the clutch for signs of wear or heat.

NEED ADDITIONAL HELP?

Website

www.rekluse.com/support

Phone

(208) 426-0659

Monday thru Friday: 8 am – 5 pm Mountain Time

Email

tech@rekluse.com



SETUP SHEET 198-7115006

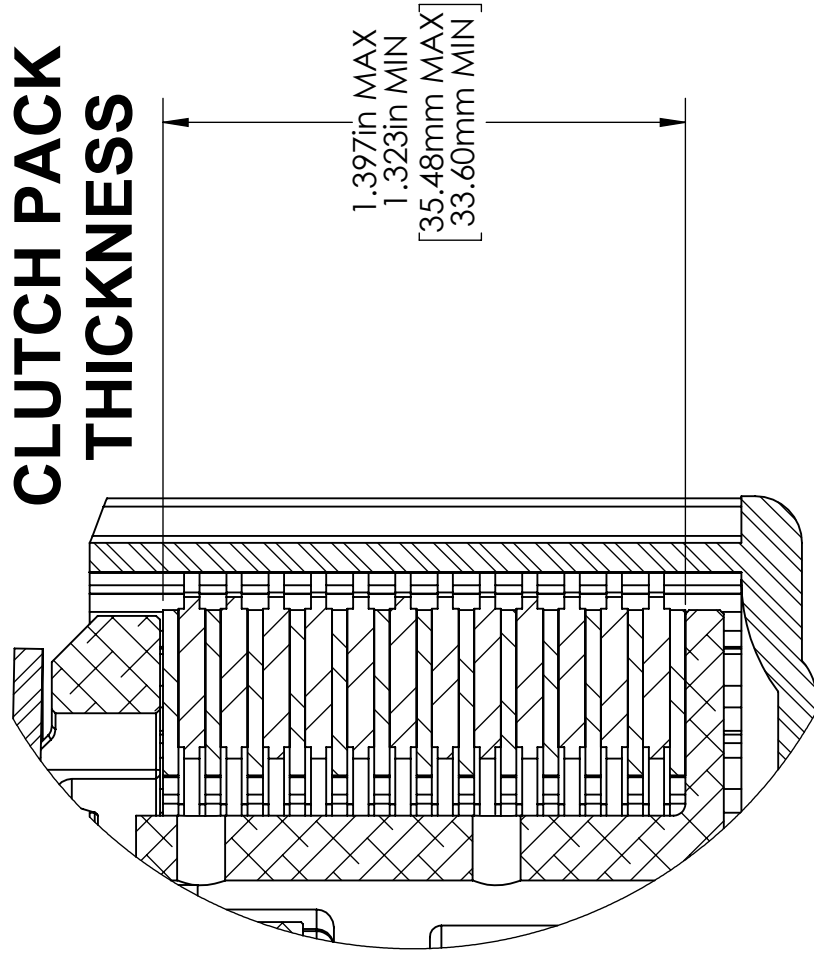
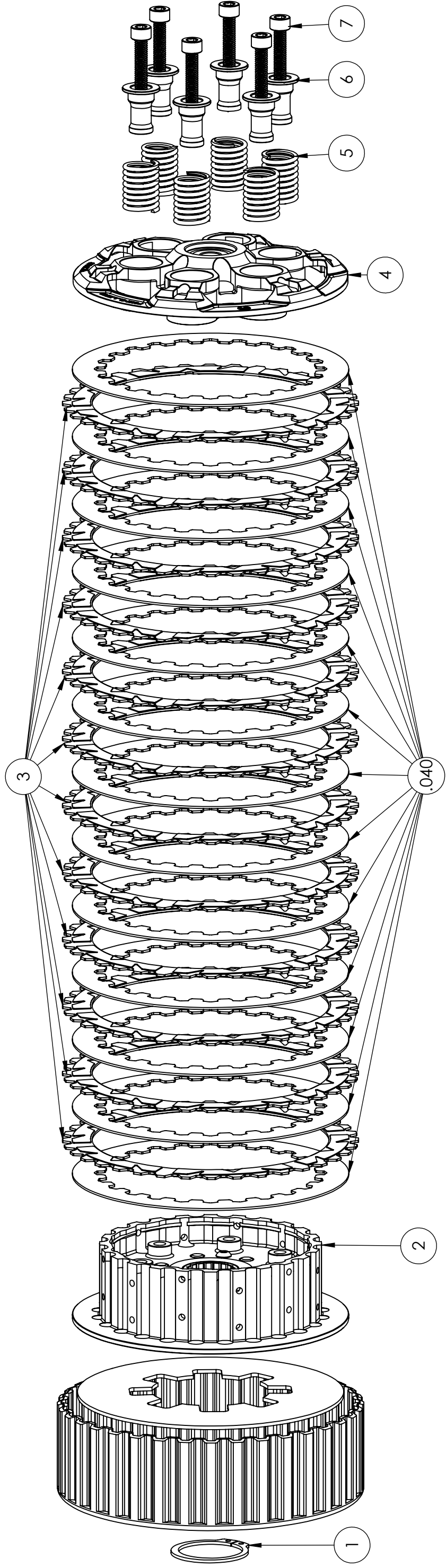

COMPONENTS

ITEM NO.	DESCRIPTION	QTY.
.040	DRIVE PLATE - .040"	13
1	RETAINING RING	1
2	CENTER HUB	1
3	TORQ DRIVE FRICTION	12
4	PRESSURE PLATE	1
5	PRESSURE PLATE SPRING	6
6	SCREW SLEEVE	6
7	M6 x 30mm SocketHeadCapScrew	6

SERVICE LIMITS

COMPONENT	STANDARD	SERVICE LIMIT
TORQDRIVE	.068-.072in	.065in
FRICTION	1.73-1.83mm	1.65mm