



READ ME FIRST

Doc ID: 193-713A
Doc Revision: 110817

There are several crucial steps that must be understood and performed to ensure your clutch will function properly. Failure to properly install and maintain your clutch components will result in premature wear or failure.

New Friction Disk Break-In

⚠ WARNING

Failure to follow the oil screen inspection process after break in could cause motor oil delivery failure which can result in motor failure, serious injury, or death.

- Following the installation of a new set of friction disks, there will be a short break in period during which the friction disks will wear in somewhat. Following this wear in period, it is vital to inspect the oil screens.
 - Soak new friction disks in oil
 - Install new friction disks
 - Ride the bike for an initial period
 - Inspect the oil screens, and change oil as necessary

Damper Inspection (DDS clutches only)

During clutch installation, inspection of the OEM dampers is necessary. Follow the inspection process found in the installation manual.

- Remove OEM components called out in the installation manual
- Follow the damper inspection process found in the installation manual
- Replace dampers if necessary



INSTALLATION & USER'S GUIDE

The Rekluse CoreManual TorqDrive Clutch Kit

Doc ID: 191-7113081A
Revision: 091019

TABLE OF CONTENTS

OVERVIEW	2
INSTALLATION TIPS	3
TOOLS NEEDED.....	3
INCLUDED PARTS	4
BIKE PREP & DISASSEMBLY	5
INSTALL HUB.....	7
INSTALL THE CLUTCH PACK	9
PRESSURE PLATE INSTALLATION.....	11
MAINTENANCE.....	13
Disk inspection examples.....	14
NEED ADDITIONAL HELP?.....	15

OVERVIEW

- This kit replaces the OE (Original Equipment) or “stock” core clutch components including the center clutch hub and pressure plate with high-quality billet components designed for optimal operation specific to your bike.
- All OE friction disks will be replaced with Rekluse TorqDrive® Frictions, and all OE steel drive plates will be replaced with Rekluse drive plates.
- OE pressure plate springs will be replaced with Rekluse springs
- All 6 of the OE drive pins will be reinstalled.
- If you install this product for a customer or another person, instruct them to read the **Safety Information** document and the **Installation and User Guide** before operating the bike with the product.

INSTALLATION TIPS

- Read the safety information sheet included with your kit.
- Protect eyes and skin – wear safety glasses and thin disposable work gloves. Work in a well ventilated area.
- Read this entire document before performing any steps.
- Laying the bike on its left side allows for easy clutch access and eliminates the need to drain oil
- An air or electric impact wrench works well to remove the center clutch nut, or you can place the bike in top gear and hold the rear brake while loosening the center clutch nut with a socket.
- Channel-lock pliers work best to bend the tabs of the washer up over the center clutch nut.
- For optimal clutch performance Rekluse recommends using fresh, clean oil that meets JASO-MA oil rating requirements. Rekluse offers Factory Formulated Oil™ developed specifically for Rekluse products. Rekluse Factory Formulated Oil is a perfect complement to any OEM or aftermarket wet clutch. Visit www.rekluse.com to learn more.

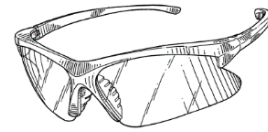

TOOLS NEEDED

- 8 mm socket
- 27 mm socket
- 5 mm Allen key
- Torque wrench (in-lb & ft-lb, or N-m)
- Channel-lock pliers

INCLUDED PARTS

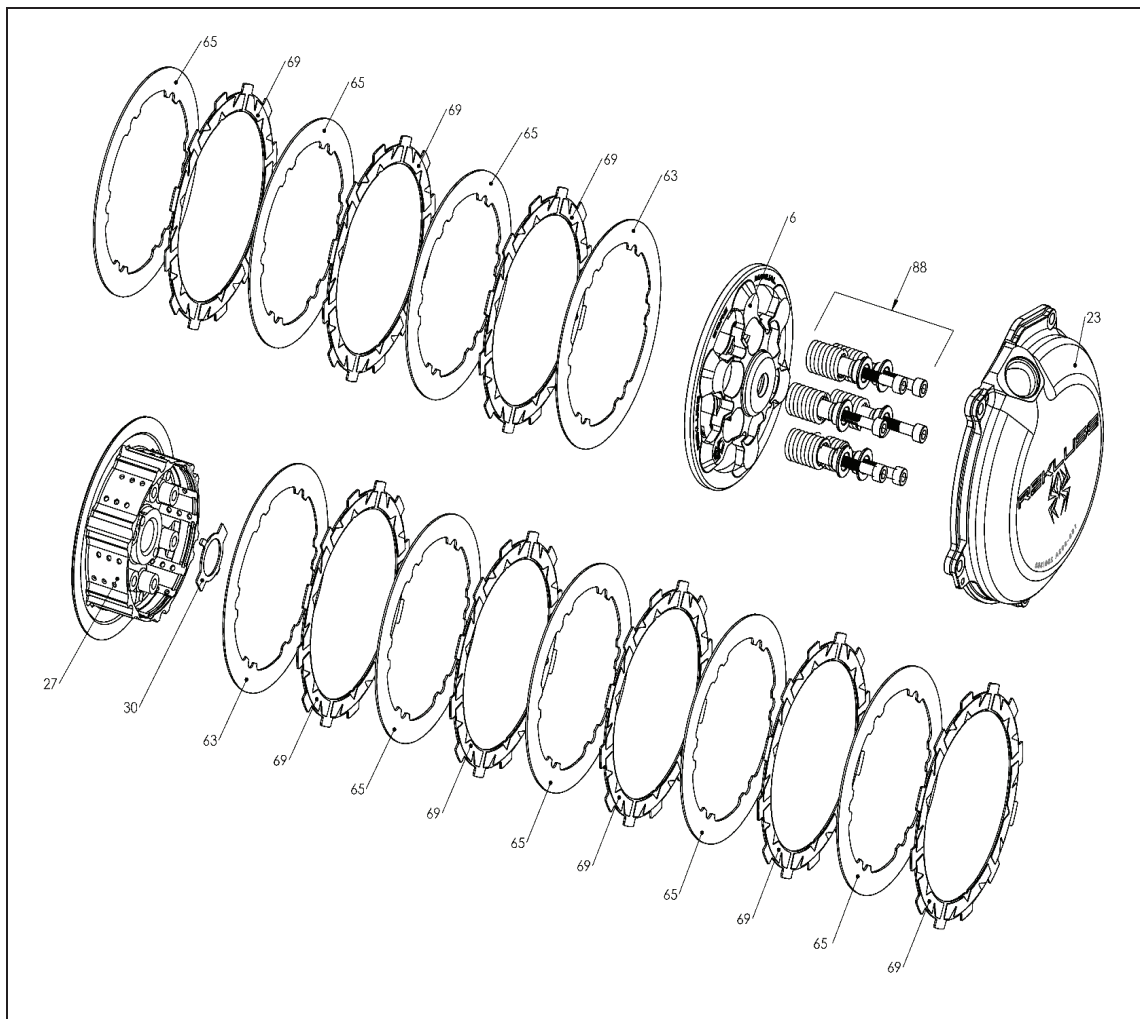

Item	Item Type	Qty
6	Pressure Plate	1
23	Clutch Cover	1
27	Hub	1
88	Core Clutch Spring Kit	6
63	Steel Drive Plate - .040" (1 mm)	2/3*
65	Steel Drive Plate - .048" (1 mm)	7
69	TorqDrive Friction Disks	8/9*

*Depending on model

Visit Rekluse.com/support for a full parts fiche illustration and part numbers.

BIKE PREP & DISASSEMBLY

1. Lay the bike on its left side. Catch any fuel that might drain in a suitable container.



2. Using a socket, remove the clutch cover bolts, then remove the clutch cover.

3. Remove the OE parts named in the following diagram.

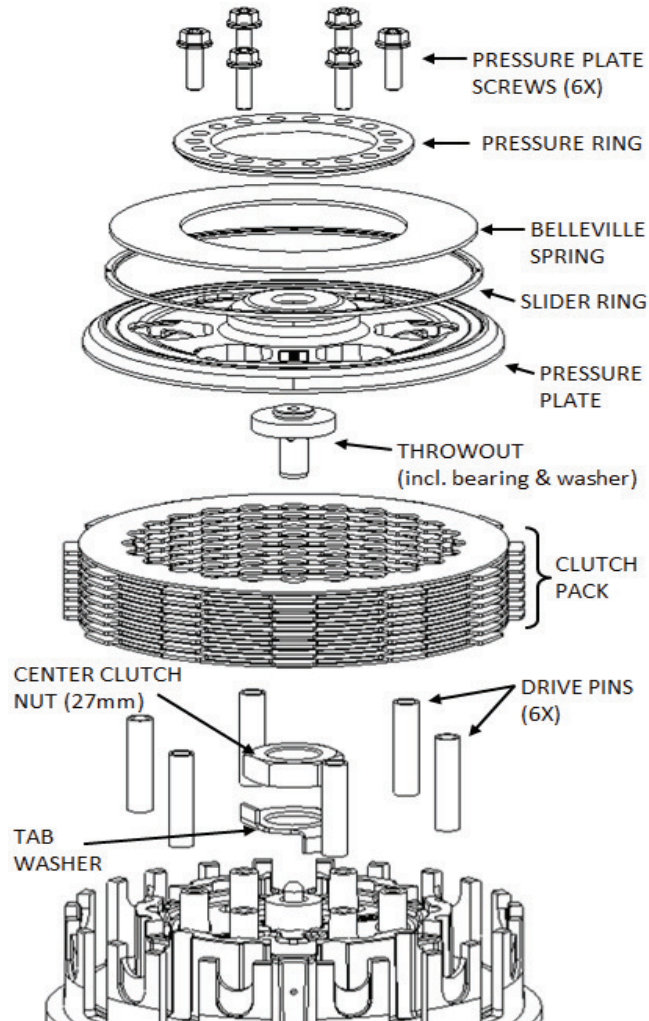

NOTES:

- Use a hammer and large screw driver to bend down the tabs of the tab washer.

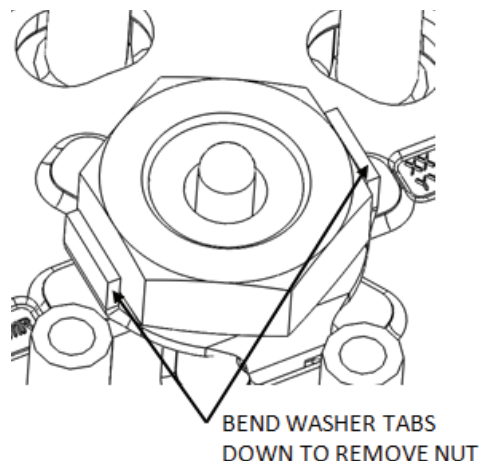

- Be careful that the drive pins do not fall into the engine while disassembling.

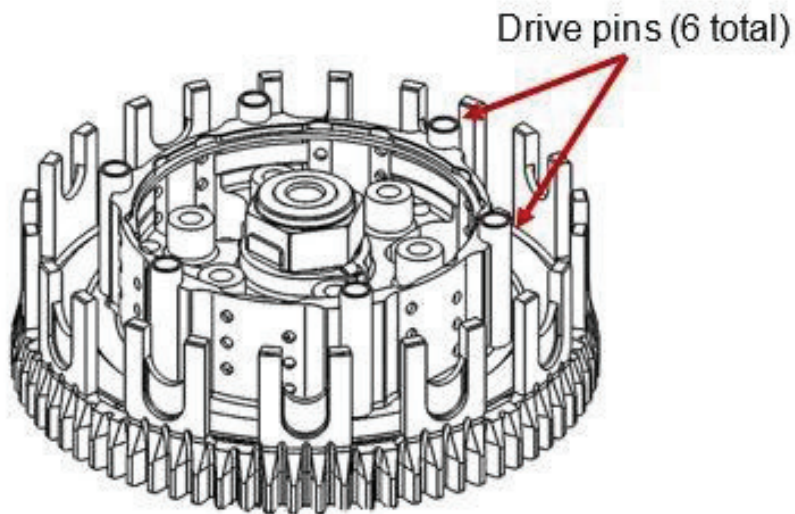

4. Soak the included friction disks in engine oil for 5 minutes.

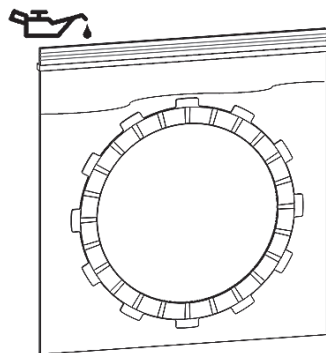

5. Remove the center hub from the bike. *Make sure the thrust washer is in place on the main shaft and not stuck to the bottom of the center hub assembly.*

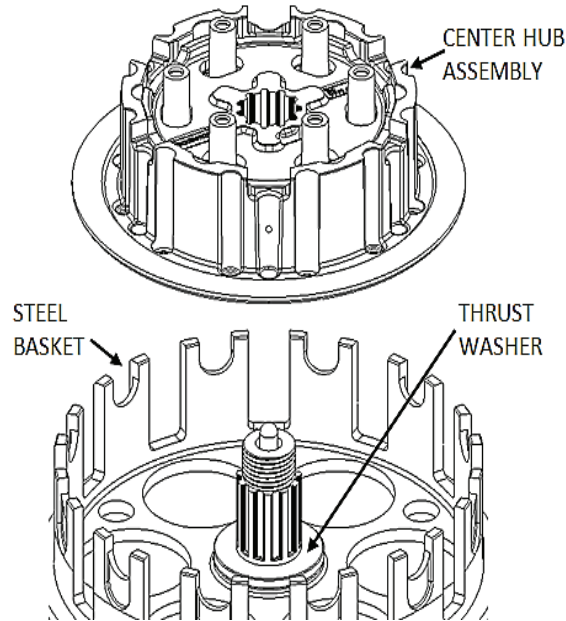

INSTALL HUB

1. Install the new Rekluse center hub into the clutch basket. *Make sure the thrust washer is on the main shaft before installing.*

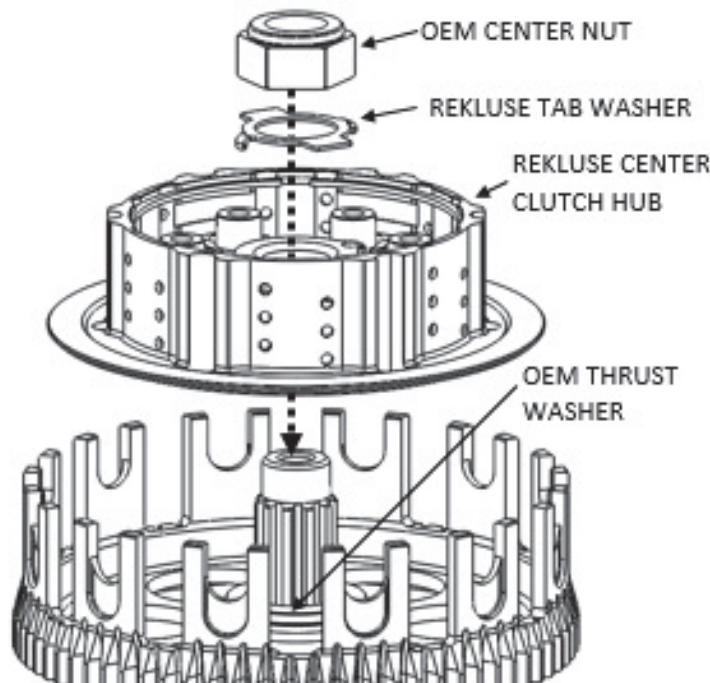

2. Install the Rekluse tab washer and OE center clutch nut.
3. Using the 27 mm socket and torque wrench, torque the center clutch nut to OE specification.
4. Using the channel-lock pliers, bend up **both** tabs of the tab washer tightly around the nut. The tabs can be bent on the straight sides or around the corners.

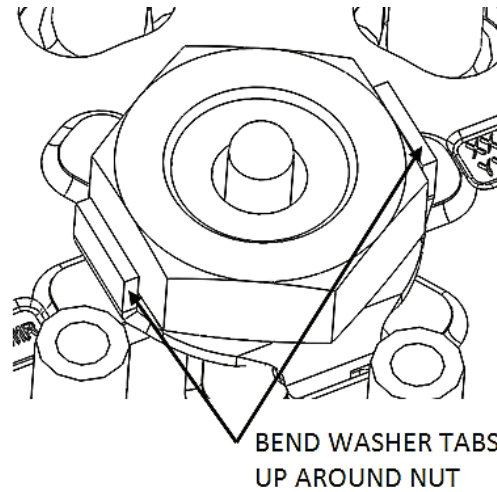

5. Seat the 6 OE drive pins into the Rekluse hub.

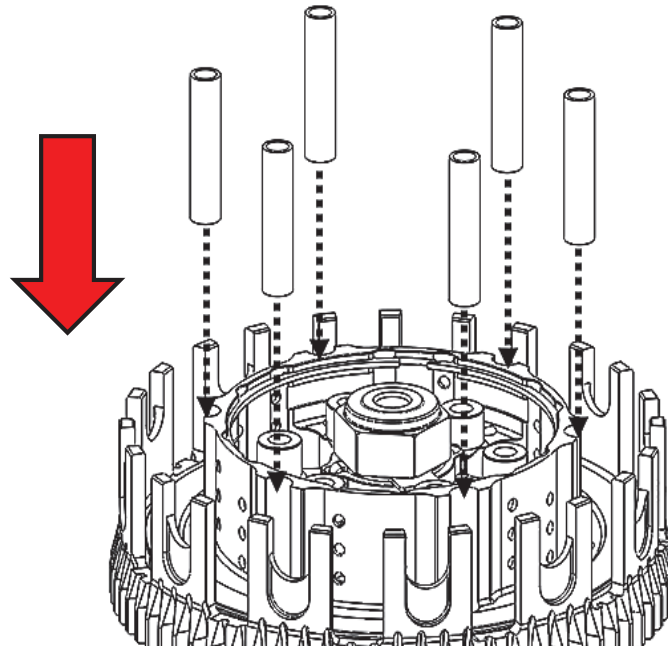

INSTALL THE CLUTCH PACK

1. Install a Rekluse steel drive plate into the clutch basket making sure that the drive pins are seated into the notches. (All drive plates will follow this orientation). *ALL the steel drive plates must be aligned in the drive pins notches or damage may occur. The plates will not move when installed correctly*

NOTE: Be sure that the drive pins are seated in the notches and not in the bigger sections.

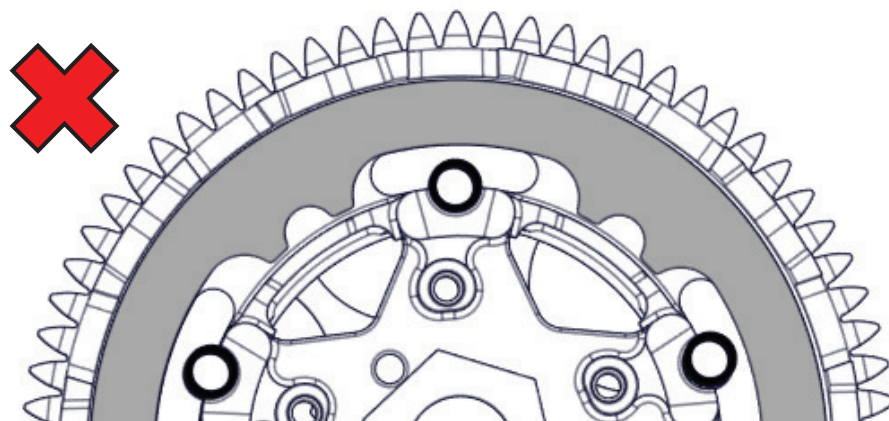
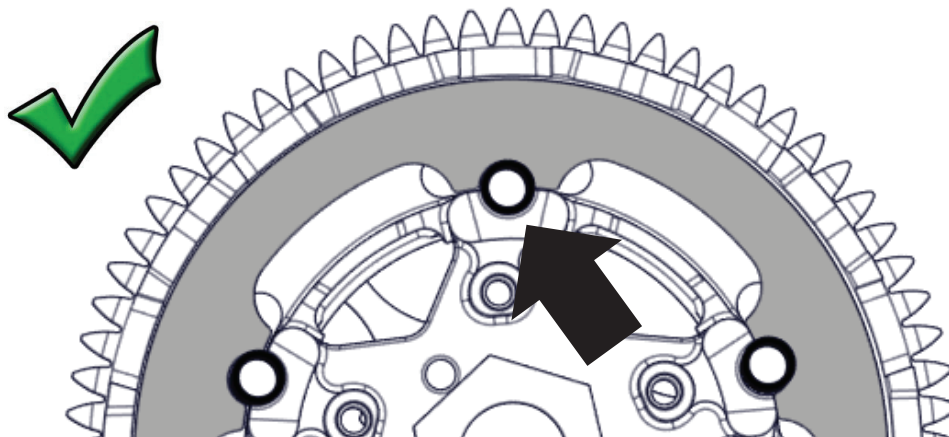

2. On top of the steel drive plate, install a Rekluse friction disk.

3. Continue to alternate steel drive plates with friction disks for the entire clutch pack. **See the Setup Sheet at the back of the manual for specific clutch pack information and measurements.**

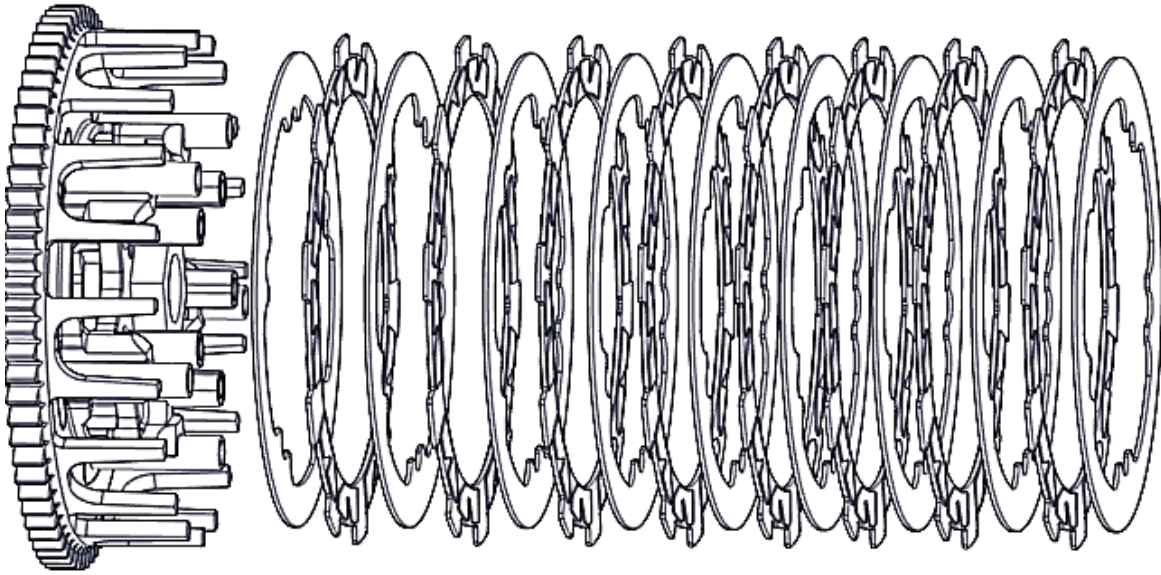

4. Reinstall the OEM throw-out.

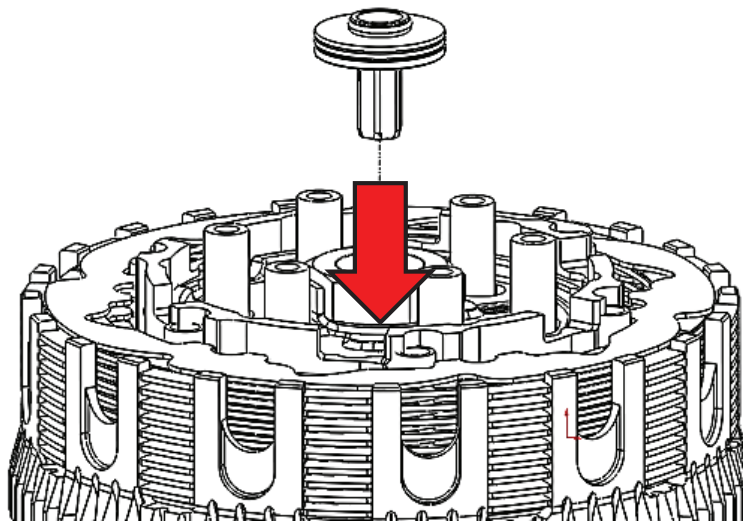

PRESSURE PLATE INSTALLATION

1. Install pressure plate.

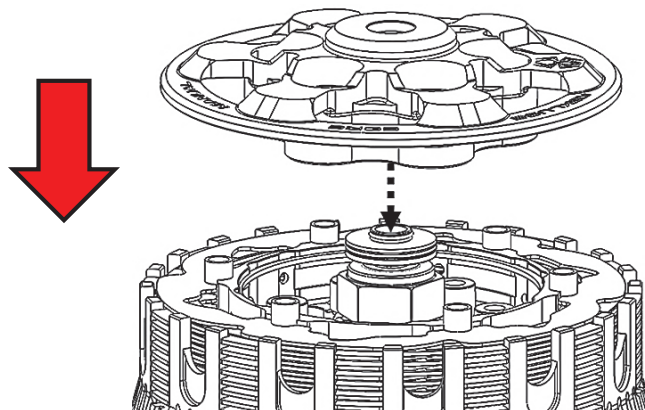

2. Install the Rekluse pressure plate springs followed by the screw sleeves.

3. Insert the pressure plate socket head screws, then torque them to 9 ft-lb (12 N-m). **Do not reuse the OEM springs!**

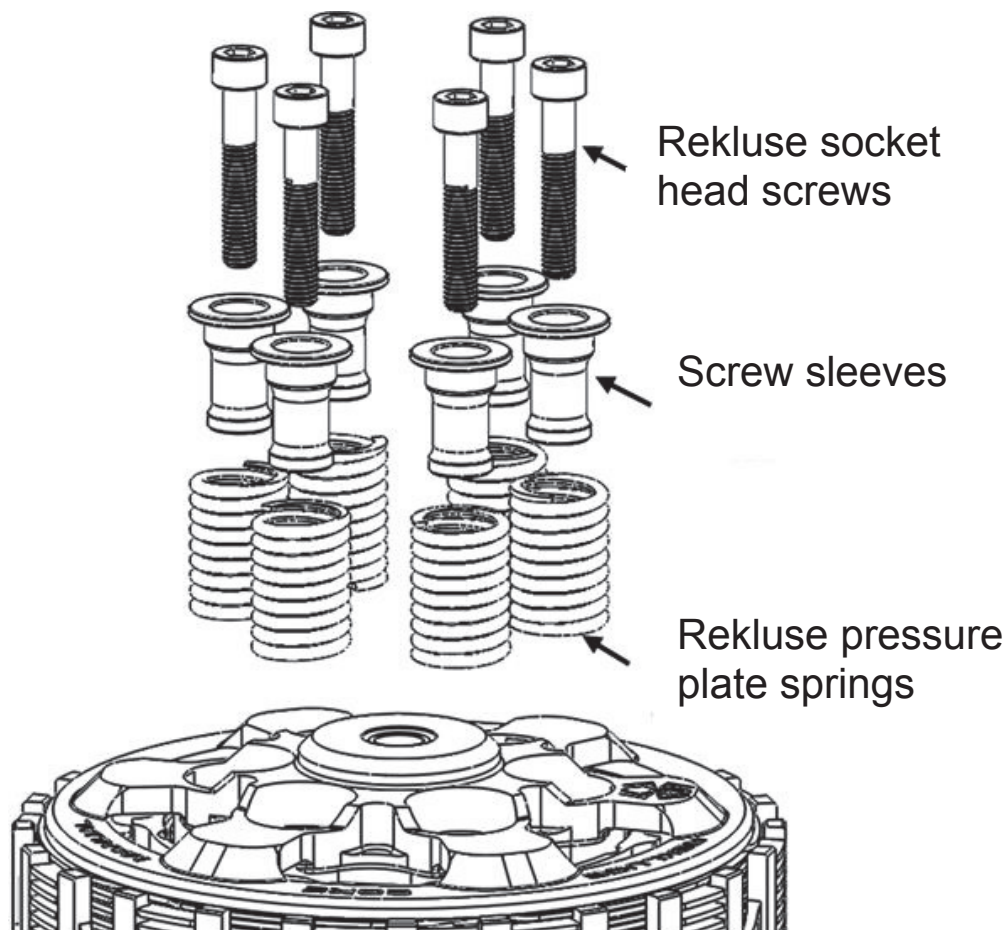

4. Install the OE cover gasket onto the Rekluse clutch cover, then install the cover onto the clutch.
5. Reinstall the clutch cover bolts, then lightly tighten the cover bolts in small increments in a star pattern. Torque the cover bolts to OE specifications.
6. If your clutch cover has an oil fill plug and/or engine inspection plug, reinstall the plug.

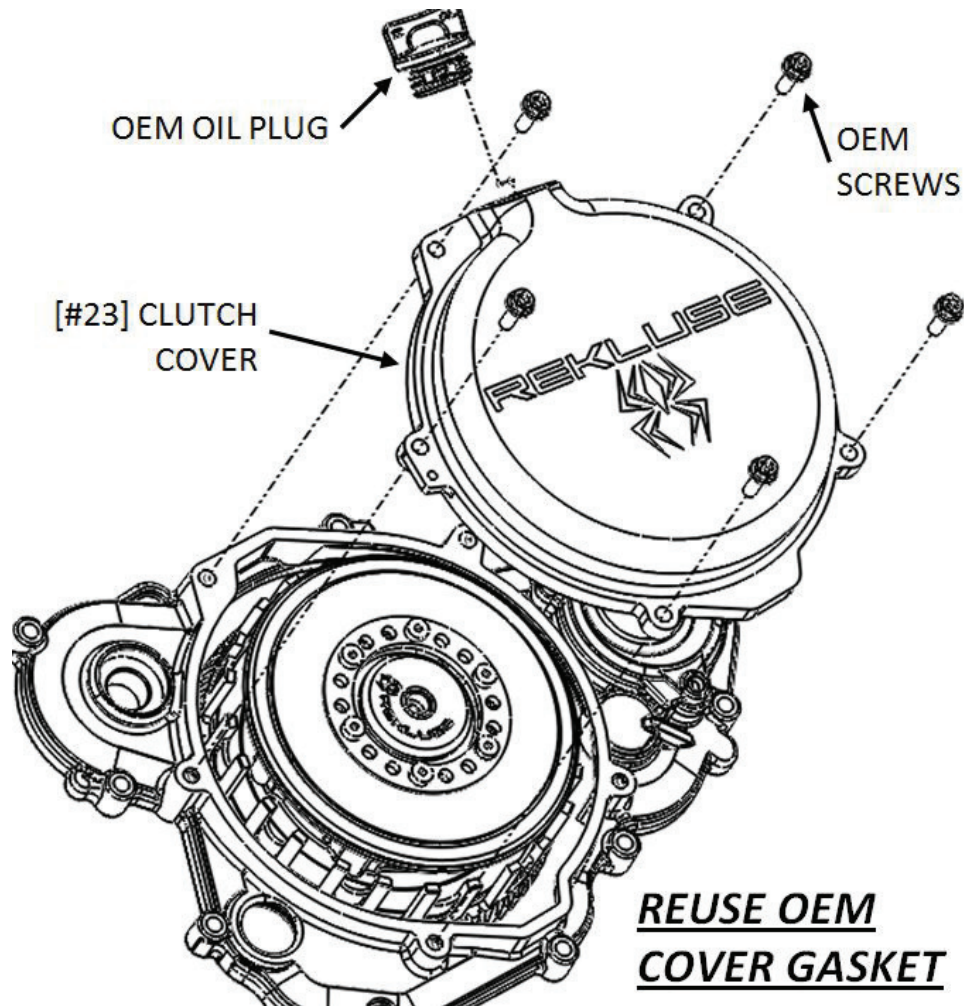

MAINTENANCE

To keep your clutch performing at its best, perform regular maintenance on your bike and clutch.

- Keep up with regular oil changes as per the bike manufacturer's recommendations. Clutch performance and longevity depend on oil quality.
- Oil recommendations can also be viewed under Tech Tips on our website at www.rekluse.com/support/videos/atv-mc-support-videos.
- Inspect all of your clutch parts for signs of wear or excessive heat, and replace components as necessary. Clutch wear is dependent on the riders use.

Maintenance Protocol	Maintenance Intervals
Inspect all clutch parts for excessive wear or heat. Replace as needed.	Refer to OE service manual
Change oil, inspect and clean oil screen	Refer to OE service manual

- Measuring the clutch pack can help determine if the components need replacing. See the Setup Sheet for the specific clutch pack measurements.
- Always soak friction disks in oil for at least 5 minutes before installing.
- Replace friction disks if they measure below specifications listed on the attached Setup Sheet or if the disks are glazed and/or burnt.
- Replace the drive plates if they show signs of excessive heat.

Disk inspection examples

When inspecting the clutch pack, the following pictures can be used as a reference. **These are best viewed in color by viewing this install document from www.rekluse.com/support.**

Drive Plates – If the clutch pack is getting high amounts of heat, purple, blue, or black color can be seen on the drive plate teeth. See pictures below. Not all drive plates look the same and may look different than pictured.

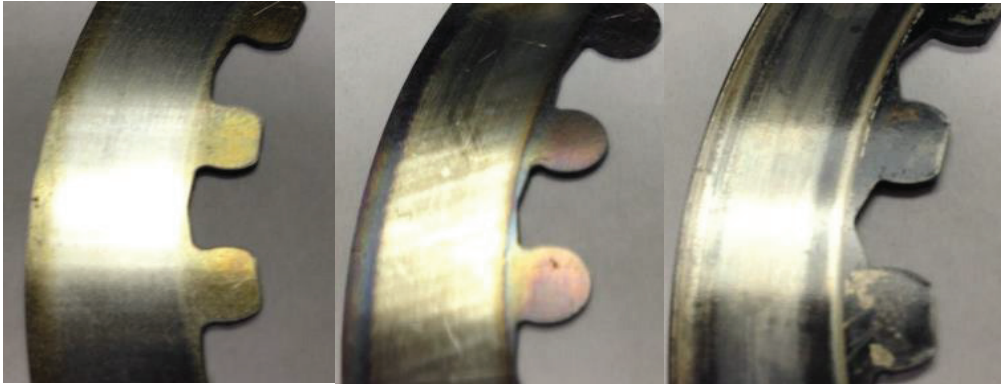

Normal Heat

High Heat
(Blue)

Excessive Heat
(Black)

Friction Disks – Due to the dark color of the friction material, the friction disks will appear almost black as soon as they are put in oil. During inspection, look for glazing of the friction material. Glazing will appear shiny and feel like glass, even after oil is cleaned from the friction disk. Not all friction disks look the same and may look different than pictured.



Normal
Friction



Glazed
Friction

NEED ADDITIONAL HELP?

Website

www.rekluse.com/support

Frequently Asked Questions

www.rekluse.com/faq

Support Videos

www.rekluse.com/support/videos

Phone

(208) 426-0659

Technical Support

Contact Technical Support for questions related to product installation, tuning, and performance.

Hours:

Monday thru Friday: 8:00 a.m. - 5:00 p.m.

Mountain Time zone

Email: tech@rekluse.com

Customer Service

Contact Customer Service for additional product information, orders, and returns.

Hours:

Monday thru Friday: 8:00 a.m. - 5:00 p.m.

Mountain Time zone

Email: customerservice@rekluse.com



SETUP SHEET 198-7113081

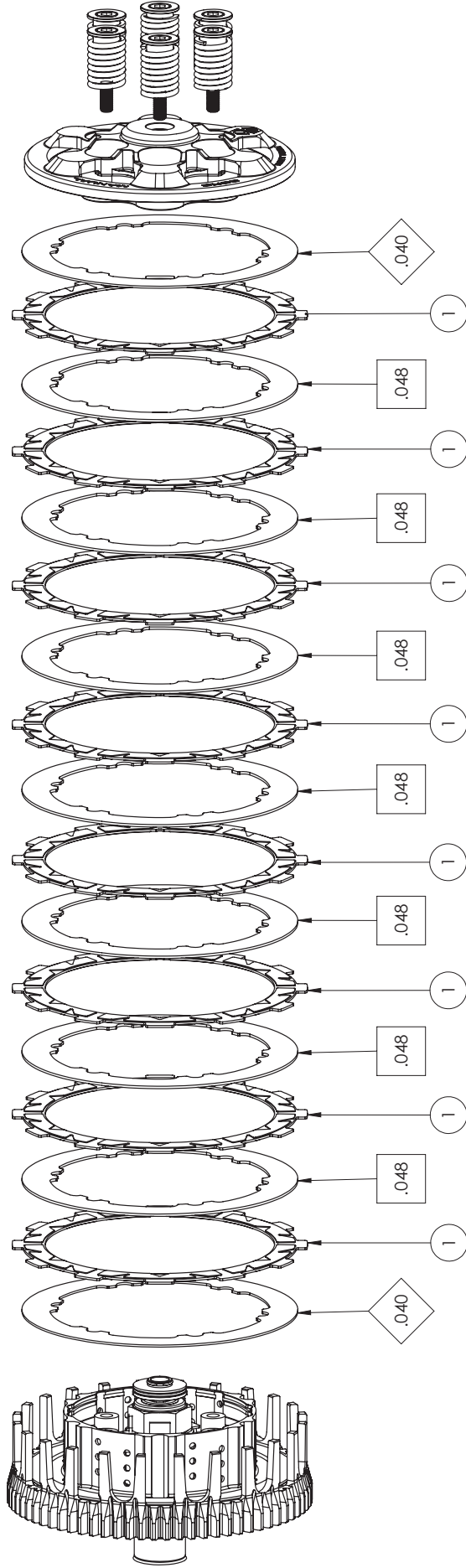

ITEM NO.	DESCRIPTION	QTY.
.040	DRIVE PLATE - DDS/CSS .040	2
.048	DRIVE PLATE (.048")	7
1	TORQDRIVE FRICTION	8
30		1
31	17+ KTM 250,350 Clutch Cover	1

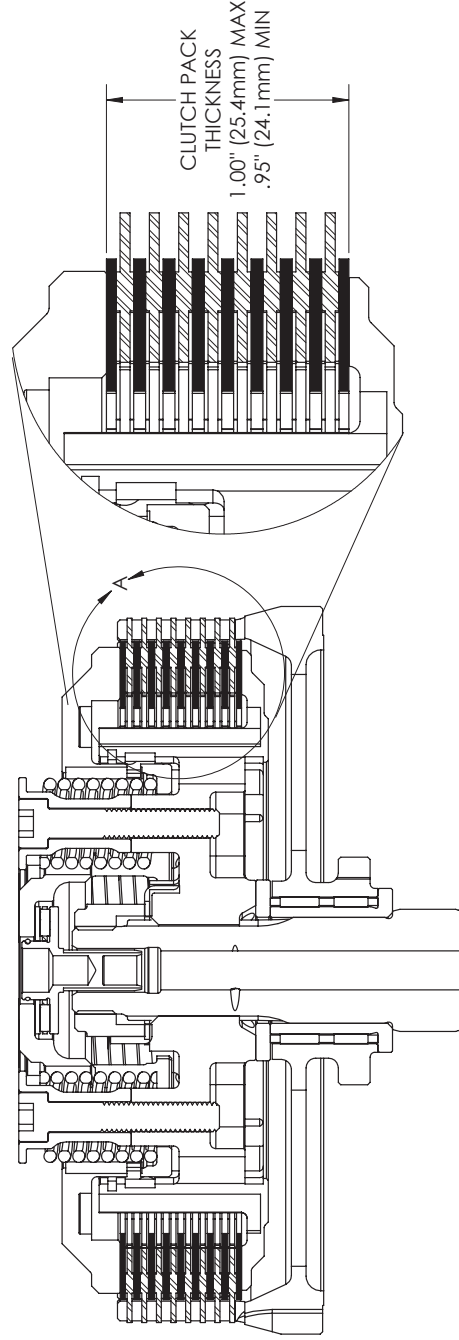

KEY:
 MIN = MINIMUM ALLOWABLE THICKNESS
 MAX = MAXIMUM ALLOWABLE THICKNESS