



INSTALLATION GUIDE

Core Manual TorqDrive

Doc ID: 191-7100

Revision: 041323

CONTENTS

OVERVIEW	2
INSTALLATION TIPS	3
TOOLS NEEDED	3
INCLUDED PARTS	3
PRESSURE PLATE SPRING SELECTION	4
BIKE PREP & DISASSEMBLY	5
INSTALLATION	6
BREAK-IN	12
TROUBLESHOOTING	12
MAINTENANCE	12
CLUTCH DISC INSPECTION EXAMPLES	14
NEED ADDITIONAL HELP?	15

OVERVIEW

- This kit will replace most of the OEM clutch parts, including the clutch pack. Only Rekluse Friction Disks can be used with the TorqDrive Product.
- The Rekluse clutch cover must be used with the TorqDrive product or interference could occur between the clutch cover and rotating clutch parts.

INSTALLATION TIPS

- Use proper eye protection
- Lay the bike on its left side to allow for easy clutch access and avoid the need to drain oil
- Use an impact wrench to remove the center clutch nut, or place the bike in top gear and hold the rear brake while loosening the center clutch nut with a socket
- Channel-lock style pliers work best to bend the tabs of the washer up over the center clutch nut
- See “Dirt TorqDrive Installation” video at Rekluse.com/videos.
- For optimal clutch performance, Rekluse recommends using fresh, clean oil that meets JASO-MA oil rating requirements. Rekluse offers Factory Formulated Oil™ developed specifically for Rekluse products. Rekluse Factory Formulated Oil is a perfect complement to any OEM or aftermarket wet clutch. Visit www.rekluse.com to learn more.



TOOLS NEEDED

- 8mm & 10mm sockets
- Center Clutch Nut Socket (27-32mm)
- 5mm Allen
- Torque wrench (in-lb & ft-lb, or N-m)
- Channel-lock pliers

INCLUDED PARTS

View the included **Setup Sheet** and visit www.rekluse.com/support for a full parts fiche illustration and part numbers.

PRESSURE PLATE SPRING SELECTION

The clutch can be tuned with the pressure plate springs to meet the rider's preference.

Do not use higher force pressure plate springs than those included in the kit.

250F

Silver springs provide a smoother clutch with a lever pull similar to OEM.

Gold springs provide a more aggressive clutch with a lever pull slightly heavier than OEM. For best performance and clutch life, gold springs are recommended.

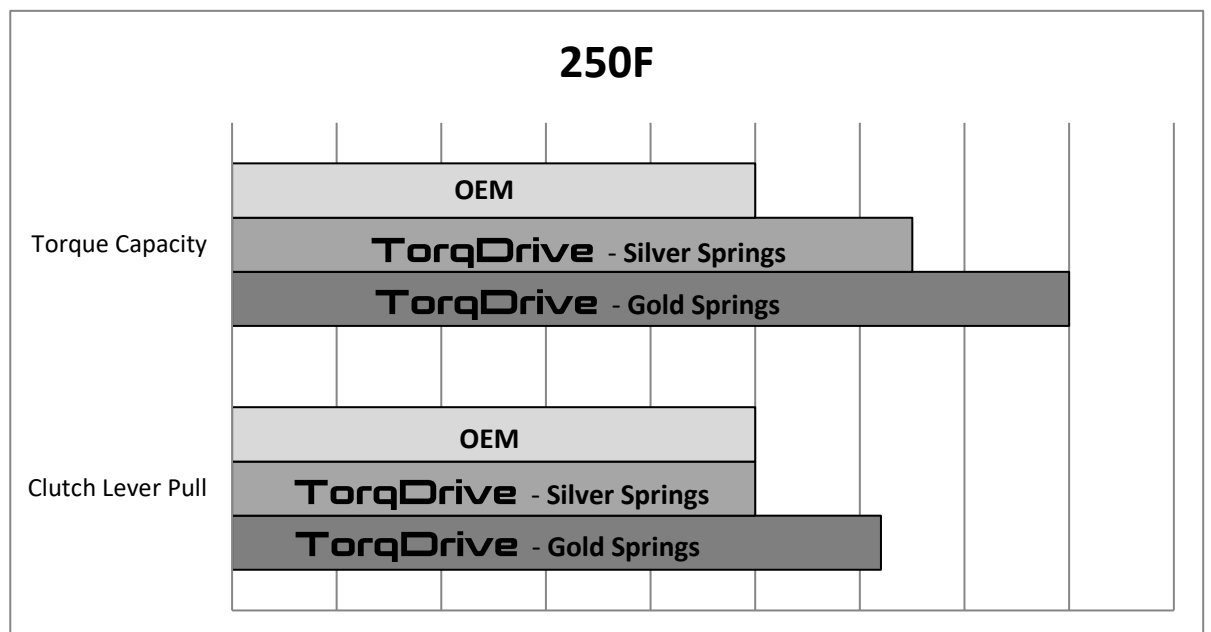

450F/250 2-Stroke:

Gold springs provide a smoother clutch with a lever pull lighter than OEM.

Red springs provide a more aggressive clutch with a lever pull similar to OEM. For best performance and clutch life, red springs are recommended.

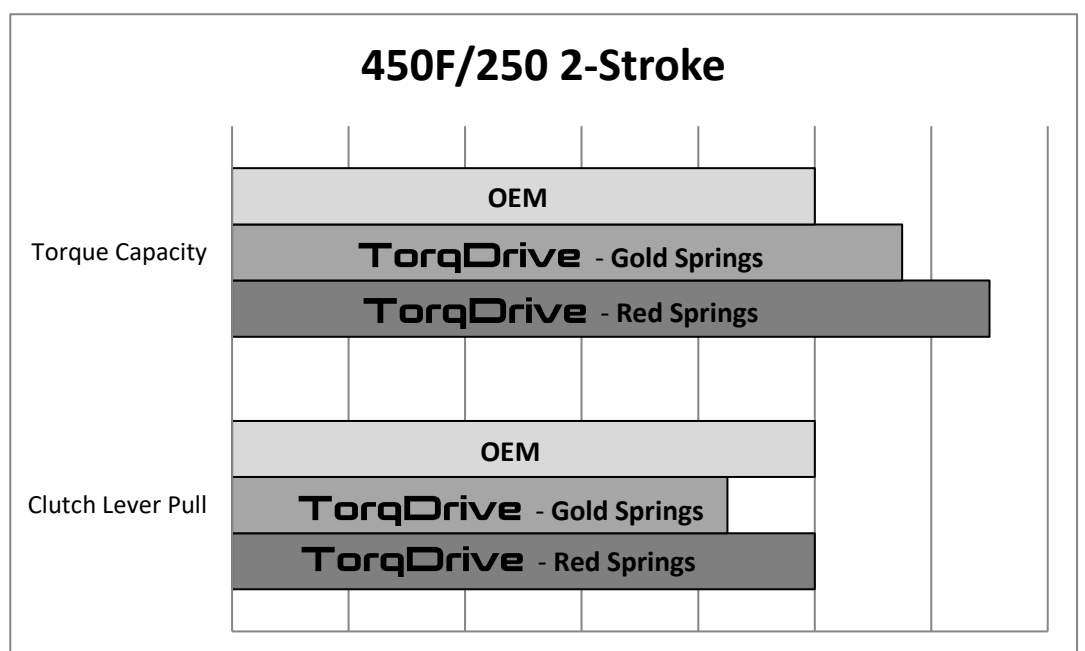

3 Red & 3 Gold springs provide a mid-range setup. Springs must be alternated to maintain even pressure on the clutch.

BIKE PREP & DISASSEMBLY

1. Turn the fuel petcock to "OFF" if applicable.

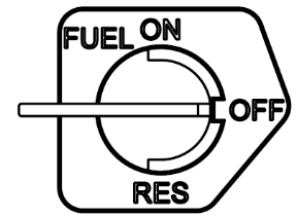

2. Lay the bike on its left side. Catch any fuel that might drain in a suitable container.



3. Remove the clutch cover.

4. Remove the OEM clutch parts named in the following diagram down to the thrust washer. Leave the thrust washer installed on the main shaft.

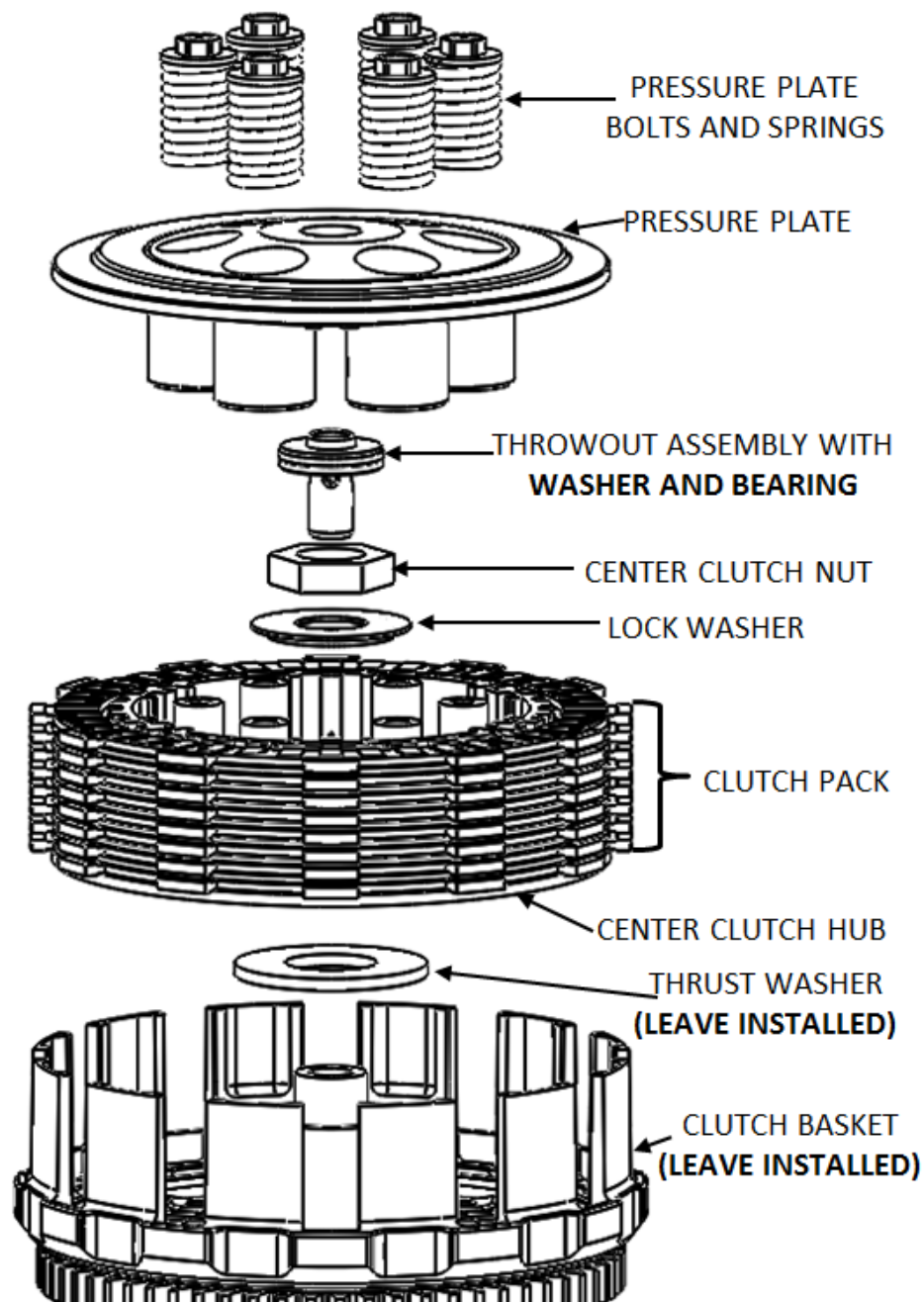

INSTALLATION

Notes for Clutch Pack Installation

- *Some OE baskets have “half slots” at the top of the basket tangs. Rekluse products require the entire clutch pack to be installed into the MAIN (deeper) basket slots. Do not use the “half slots” (see below).*



- *Inspect the clutch basket for damper and/or spring play.*
- *Inspect the clutch basket for notching. Do not install sleeves or use this product with a notched basket. Notched basket tang faces can cause the sleeves to break. Do not use baskets that have been filed, machined, or modified on the tangs. Replace the basket if necessary.*

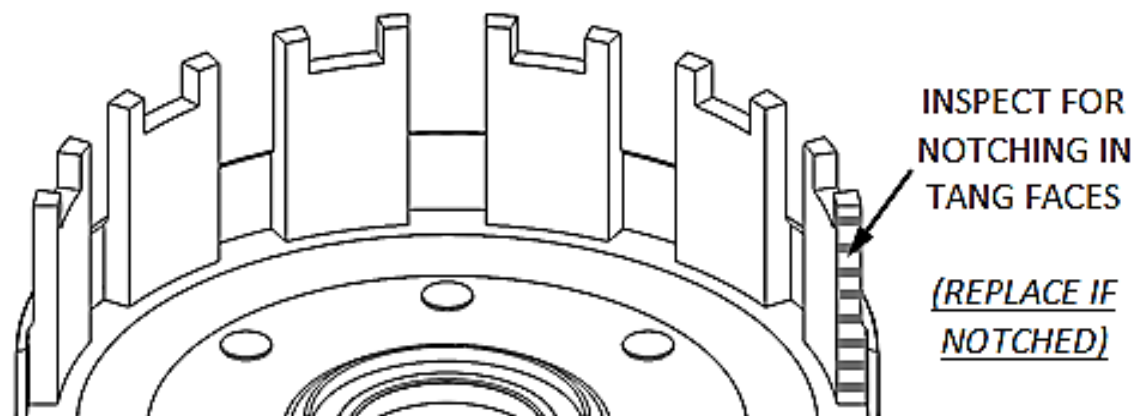

⚠ WARNING

Failure to inspect the basket and replace it if necessary could result in death, serious injury, and/or property damage.

Note: *If the basket is notched or worn, Rekluse recommends replacing it with a Rekluse Billet Clutch Basket (available for most models).*



5. Install the Rekluse Center Clutch Hub, making sure the OEM thrust washer is in place.

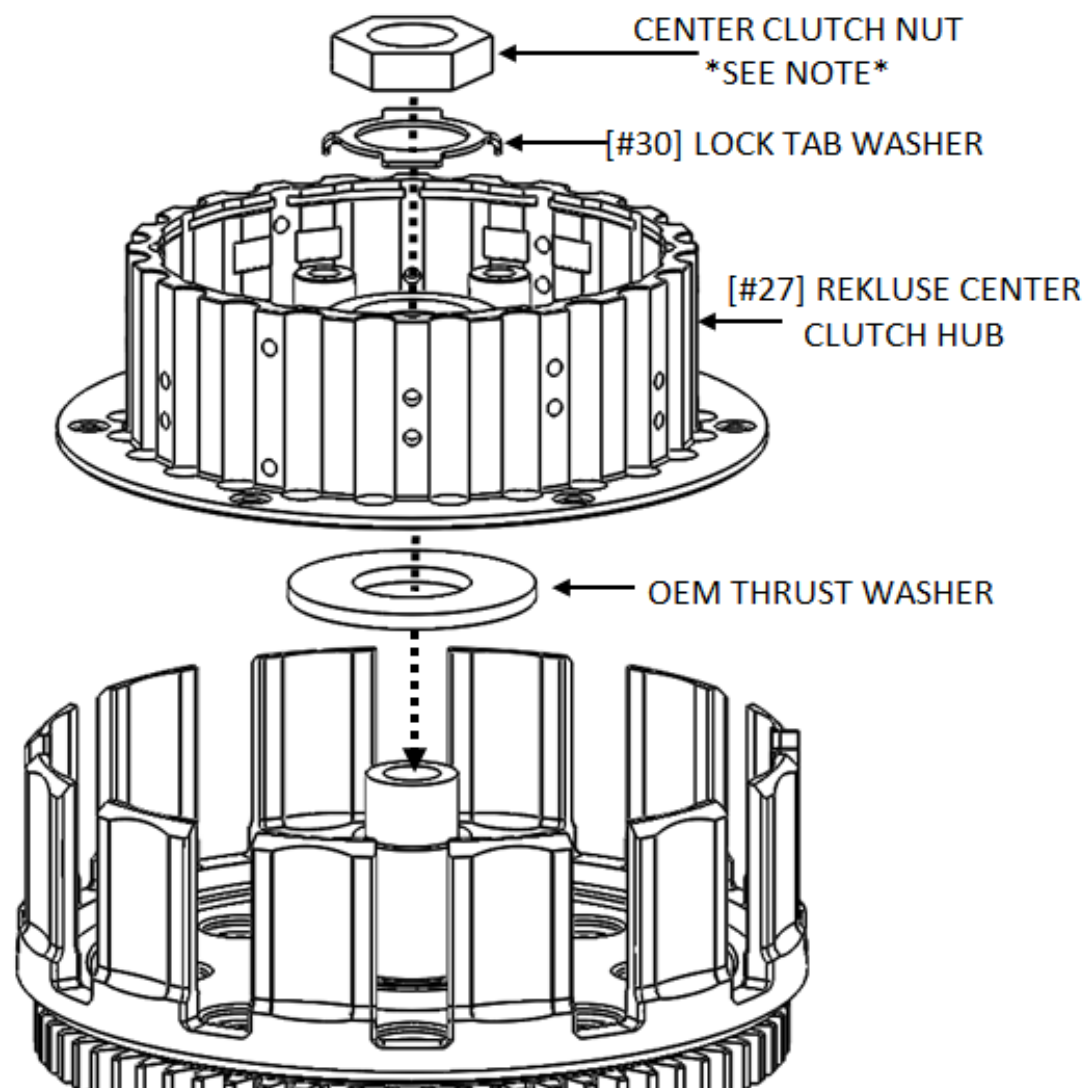

Note: Use the Rekluse supplied lock tab washer (#30). **Do not** reuse the OE lock washer.

For RMZ450, KX450F, KX250F only:

Install the included Rekluse Center Clutch Nut.
Hex size = 1¼" (32mm).

6. Torque the nut to **50 ft-lb (68 N-m)**, and bend up **both** tabs of the tab washer using channel-lock pliers. After torquing check to see that the center clutch rotates freely with the bike in neutral. Over-torquing the nut can cause excessive clutch drag.

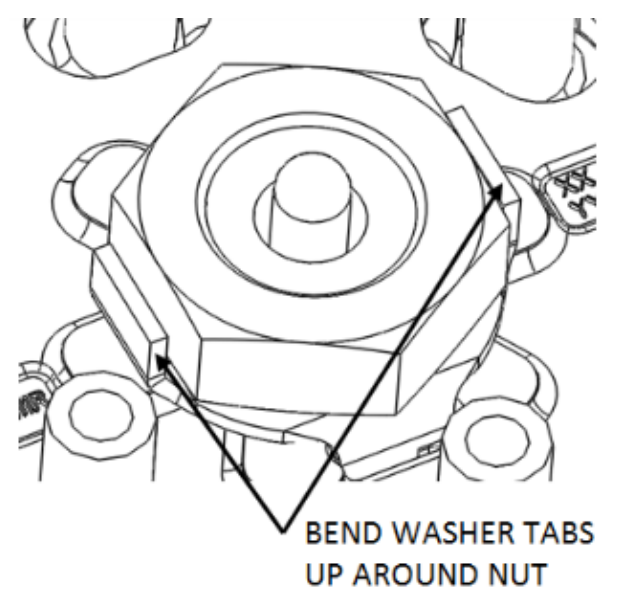

7. Install the [#70] Rekluse basket sleeves in the orientation shown making sure they are seated in the basket slots.

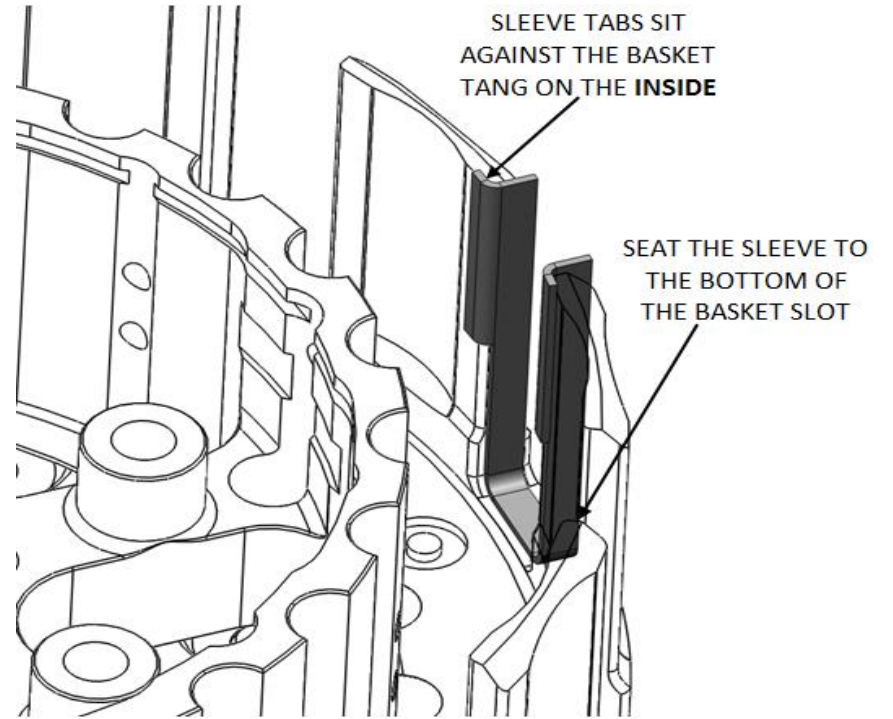
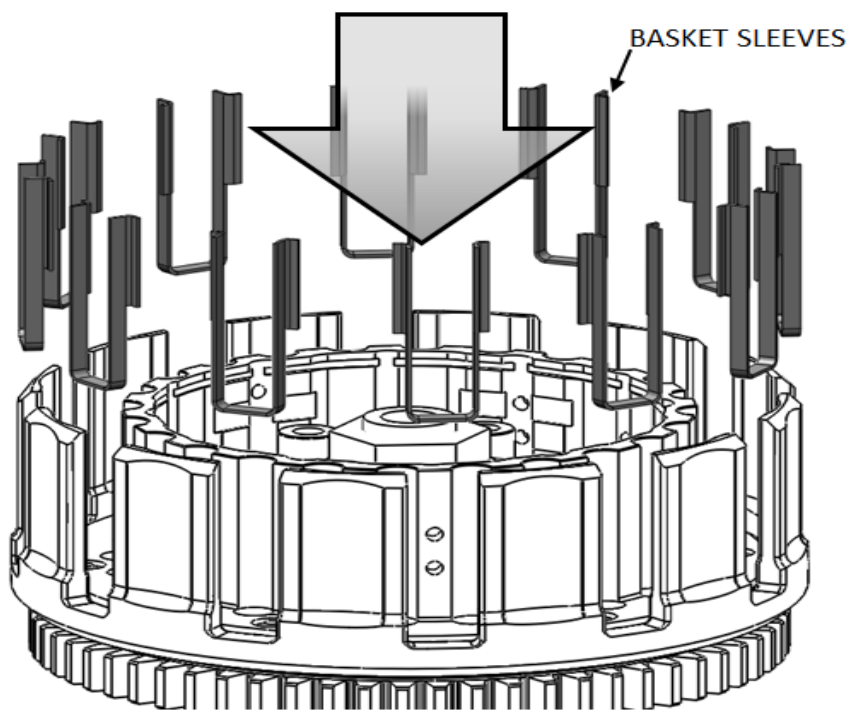

Note: When seated in the basket the sleeves may stick above or below the top of the basket



⚠ WARNING

Rekluse basket sleeves are designed to be installed into an OE or Rekluse clutch basket **ONLY**. The use of non-Rekluse aftermarket clutch baskets may cause clutch damage or failure.

8. Install the clutch pack starting with a drive plate. Alternate drive plates and friction disks until all drive plates and frictions are installed ending with a friction disk.

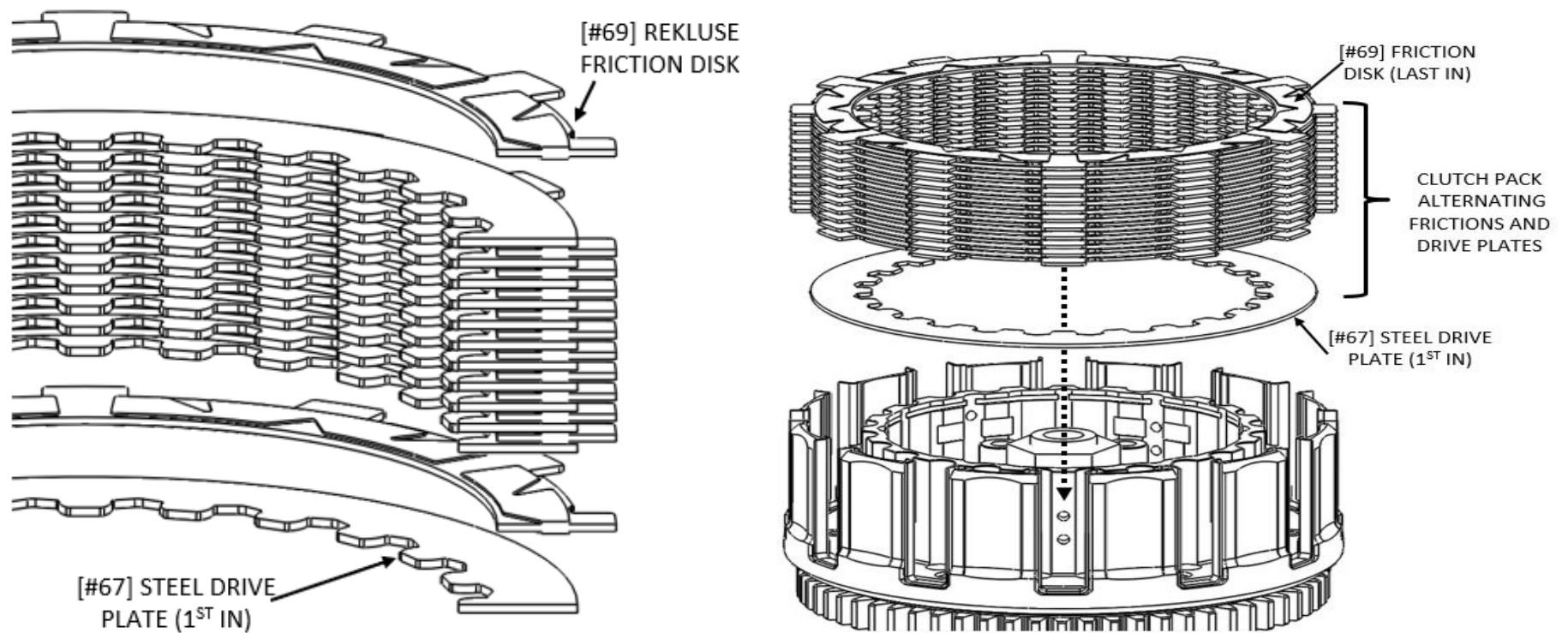

Tip: The use of picks can help keep the sleeves in place during installation. See the install video for more info.

9. Reinstall the OEM throwout assembly **with the washer and bearing**. The washer may have stuck to the OEM pressure plate.

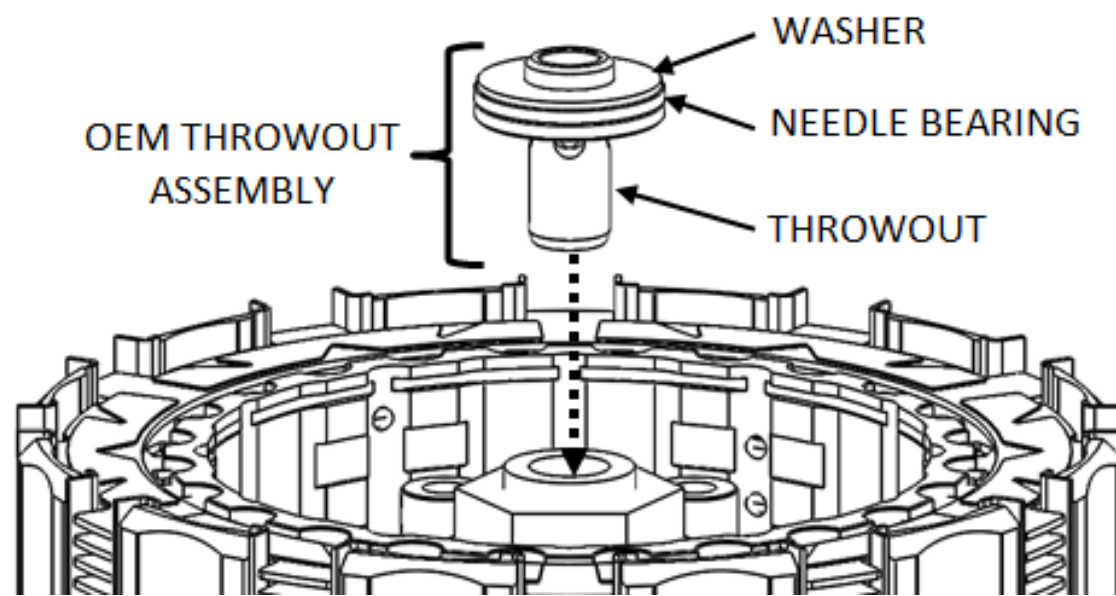

For YZ250 2-Stroke only:
Install the included spacer on the OEM throw-out.

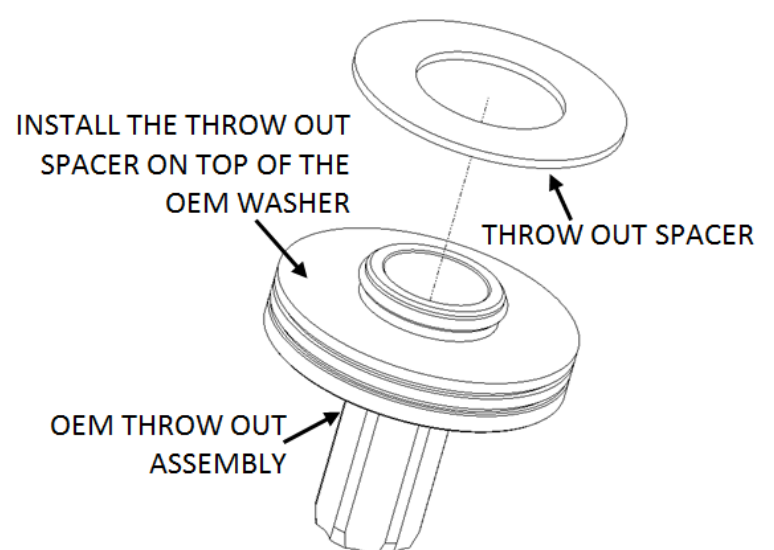

10. Install the Rekluse Pressure Plate.

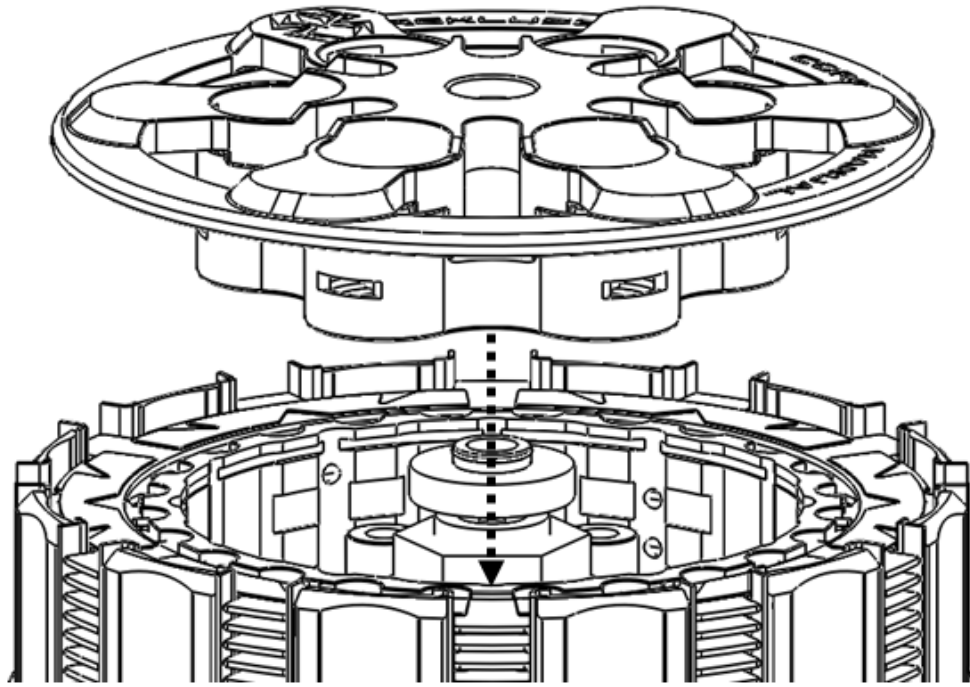

11. Install the Rekluse pressure plate springs and torque the pressure plate bolts. See “PRESSURE PLATE SPRING SELECTION” for more details. **Do not reuse the OEM springs.**

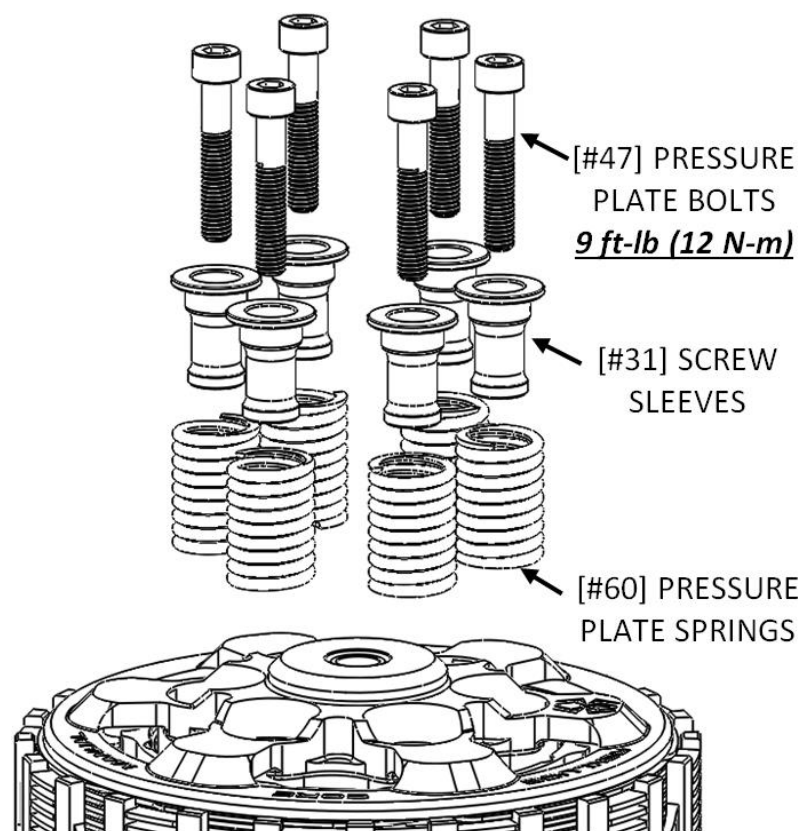

12. Install the Rekluse clutch cover, torquing the cover bolts to OEM specification. Reuse OEM clutch cover gasket.

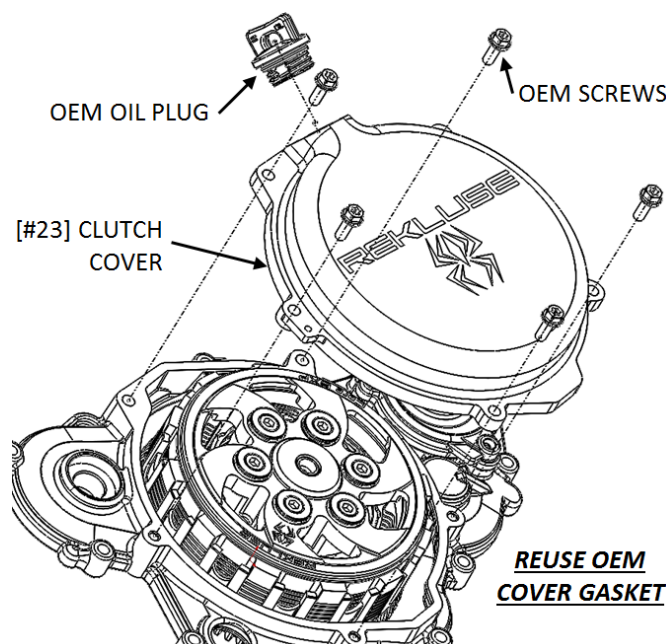

13. Readjust lever free play to OEM Specification (typically 10-20mm)



For YZ250 2-Stroke and TRX450 ATV models only: To provide clearance between the cover and brake pedal, install the included brake pedal spacing washer between the frame and brake pedal. Be sure to match the OEM torque specifications and reuse the OEM cotter pin. Rekluse recommends using a medium-strength thread-locking compound while reinstalling the OEM brake pedal bolt.

For TRX450 ATV Kick-Start Models only: You must modify your kick-start lever to clear the clutch cover. Interference will occur with your kick-start lever unless it is modified similarly to the photos below. Be sure not to damage the structural integrity of the lever. Rekluse will not warrant a damaged clutch cover or kick-start lever.



BREAK-IN

Break-in will occur over the first 1-2 hours of use, depending on the rider. During break-in, more clutch drag may occur than normal.

TROUBLESHOOTING

Clutch Drag:

- **Cold Drag Only** – If drag occurs only while the bike is cold, oil is the most likely cause. Be sure to warm up the bike before riding/racing.
- **Hot and Cold Drag** – Ensure that the center clutch nut is properly torqued so that the center clutch spins freely. Check for warped drive plates or frictions.

Clutch Slip:

- If clutch slip occurs, inspect the clutch for signs of wear or heat.
- Use of the heaviest springs included with the kit will reduce the chance of clutch slipping and/or excessive heat.

MAINTENANCE

To keep your clutch performing at its best, perform regular maintenance on your bike and clutch.

- Keep up with regular oil changes as per the bike manufacturer's recommendations. Clutch performance and longevity depend on oil quality.

Rekluse offers Factory Formulated Oil™ developed specifically for Rekluse products. Rekluse Factory Formulated Oil is a perfect complement to any OEM or aftermarket wet clutch. Visit www.rekluse.com to learn more.

Oil recommendations can be viewed under Tech Tips on our website at www.rekluse.com/support/videos/atv-mc-support-videos.

- Inspect all of your clutch parts for signs of wear or excessive heat, and replace components as necessary. Clutch wear is dependent on the rider's use.
- Inspect and replace basket sleeves if they appear to be notched from friction disks. Rekluse recommends replacing them every 25 hours for abusive riding/racing, every 50 hours for moderate riding, or every time friction disks are replaced.
- Measuring the clutch pack can help determine if the components need replacing. See the Setup Sheet for the specific clutch pack measurements.
- Replace friction disks if they measure below the specifications listed on the attached Setup Sheet or if the disks are glazed and/or burnt.
- Replace the drive plates if they show signs of excessive heat.

CLUTCH DISC INSPECTION EXAMPLES

These are best viewed in color at Rekluse.com.

Drive Plates – If the clutch pack is getting high amounts of heat, purple, blue, or black color can be seen on the drive plate teeth. See the pictures below.

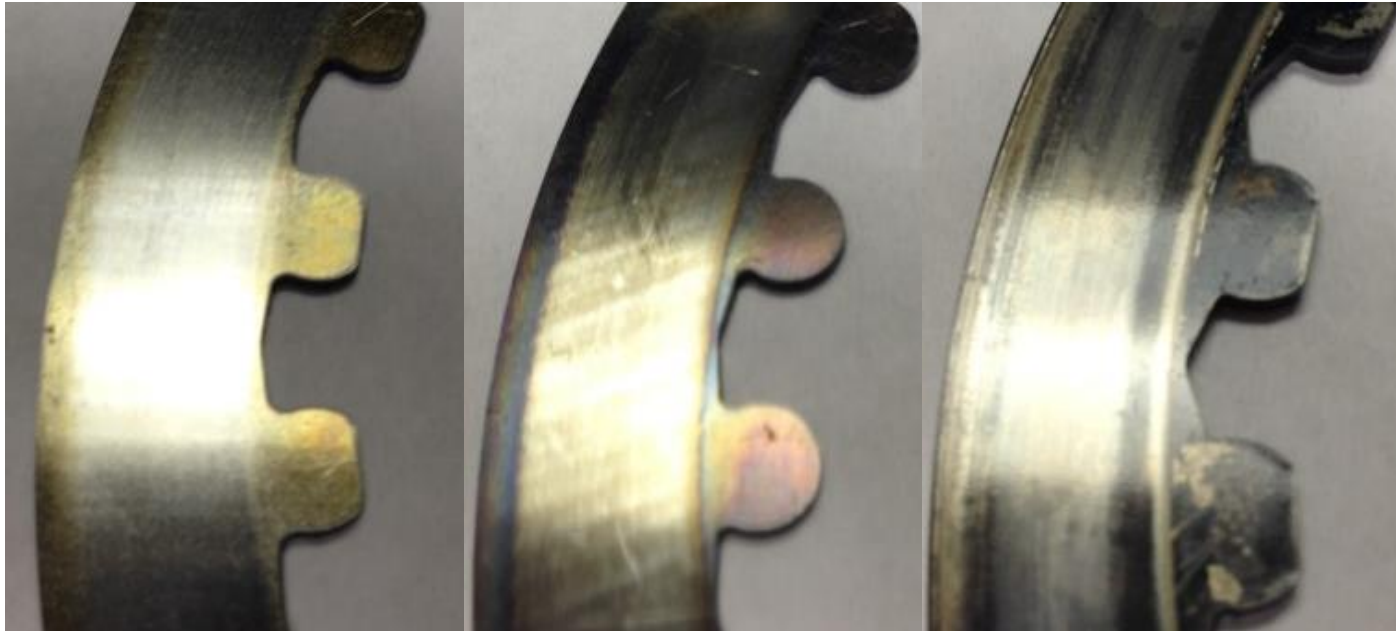

Normal Heat

High Heat
(Blue)

Excessive Heat
(Black)

Friction Disks – Due to the dark color of the friction material, the friction disks will appear almost black as soon as they are put in oil. During an inspection, look for glazing of the friction material. Glazing will appear shiny and feel like glass, even after the oil is cleaned from the friction disk.



Normal Friction

Glazed Friction

NEED ADDITIONAL HELP?

Website

www.rekluse.com/support

Phone

(208) 426-0659

Monday thru Friday: 8 am – 5 pm Mountain Time

Email

tech@rekluse.com



SETUP SHEET 198-7113

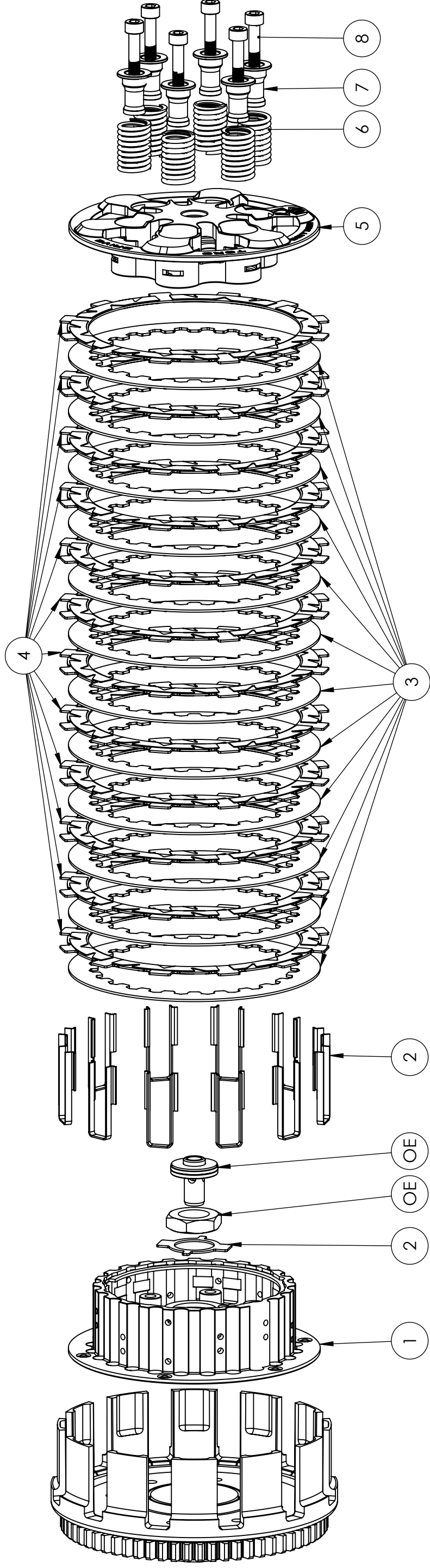

CLUTCH PACK THICKNESS

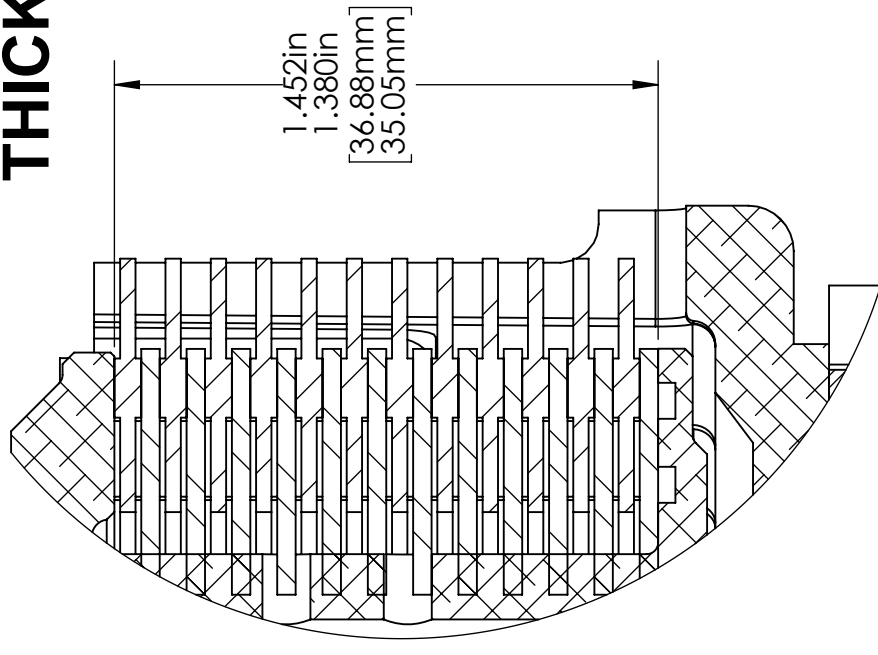

SERVICE LIMITS

COMPONENT	STANDARD	SERVICE LIMIT
TORQDRIVE FRICTION	.068-.072in 1.73-1.83mm	.065in 1.65mm

COMPONENTS

ITEM NO.	DESCRIPTION	QTY.
1	CENTER CLUTCH	1
2	LOCK WASHER	1
2	BASKET SLEEVE	12
3	DRIVE PALTE	12
4	TORQDRIVE FRICTION	12
5	PRESSURE PLATE	1
6	PRESSURE PLATE SPRINGS	6
7	SCREW SLEEVE	6
8	M6X40 SOCKET CAP SCREW	6
OE	OE COMPONENTS	VAR