



INSTALLATION & USER'S GUIDE

CoreManual TorqDrive[®] Kit
for Sherco 450/500 4T (17+)

Doc ID: 191-7108014A
Revision: 041423

Table of Contents

OVERVIEW	2
INSTALLATION TIPS	3
TOOLS.....	4
INCLUDED PARTS	4
DISASSEMBLE CLUTCH.....	5
BASKET OVERVIEW & DISASSMBLY	9
INSTALL THE HUB	13
INSTALL THE CLUTCH PACK	14
Pressure Plate Spring Information.....	15
FINISH INSTALLATION	16
BREAK IN	17
MAINTENANCE.....	18
NEED ADDITIONAL HELP?.....	20

OVERVIEW

This kit replaces OE (Original Equipment) or “stock” core clutch components including the center clutch hub, basket, and pressure plate with high-quality billet components designed for optimal performance specific to your bike.

- All the OE friction disks will be replaced with Rekluse TorqDrive® friction disks.
- All OE steel drive plates will be replaced with Rekluse drive plates.
- Two sets of pressure plate springs are included in the kit.

INSTALLATION TIPS



- Read the separate included Safety Information document before operating the vehicle with the product installed.
- Read this entire document before performing any steps.
- If you install this product for a customer or another person, instruct them to read the **Safety Information** document and the **Installation and User Guide** before operating the vehicle with the product.
- Protect eyes and skin – wear safety glasses and work gloves.
- Lay the bike on its left side when replacing the clutch. This makes working on the clutch easier and eliminates the need to drain the oil.
- Use an air or electric impact wrench to remove the center clutch nut. If one is not available, you can place the bike in top gear and hold the rear brake while loosening the center clutch nut with a socket and breaker bar.
- Channel-lock pliers work best to bend the tabs of the washer up over the center clutch nut.
- For optimal clutch performance Rekluse recommends using fresh, clean oil that **meets JASO-MA** oil rating requirements. Rekluse offers Factory Formulated Oil™ developed specifically for Rekluse products. Rekluse Factory Formulated Oil is a perfect complement to any OEM or aftermarket wet clutch. Visit www.rekluse.com to learn more.
- Use the torque values listed in the instructions. Otherwise, use the torque specifications found in your OE service manual.

TOOLS

- Metric socket set (at least 8 mm & 10 mm)
- 30 mm socket (for stock center clutch nut removal)
- Torque wrench (in-lb & ft-lb, or N-m)
- Channel-lock pliers
- Metric hex keys (5mm)
- Center punch
- Hammer
- Drill dress or drill
- 1/4" driver
- Coolant catch pan

INCLUDED PARTS

View the included **Setup Sheet** and visit www.rekluse.com/support for a full parts fiche illustration and part numbers.

DISASSEMBLE CLUTCH

1. Drain the coolant from the drain port at the water pump

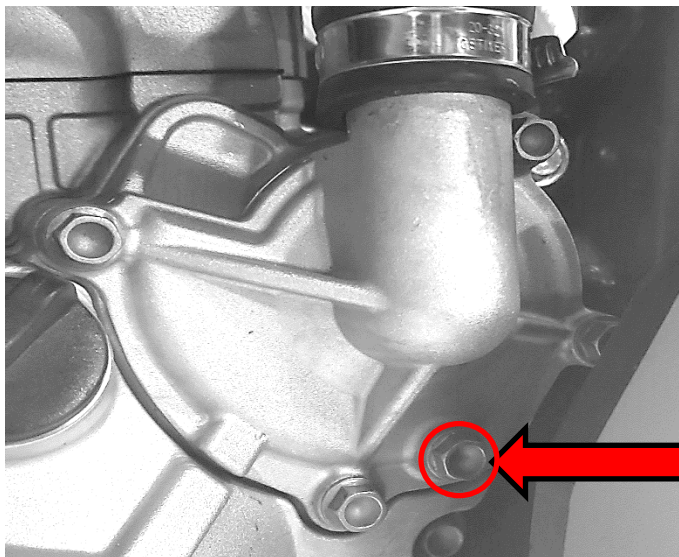

Drain Port
Screw

2. Using an 8 mm socket, remove the OE clutch cover. Pay close attention to the length and location of the OE screws so

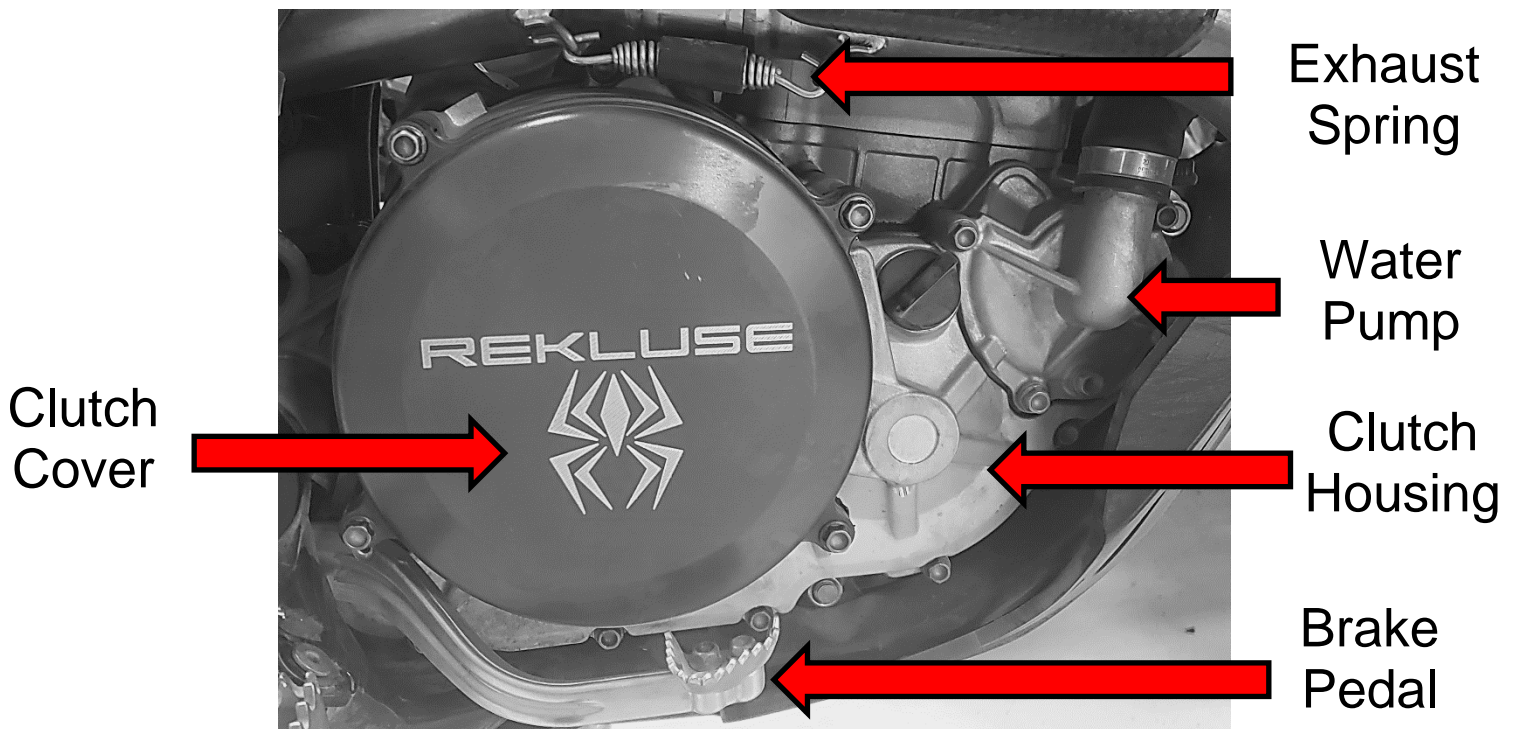

they can each be returned to the same location.

3. Remove the water pump from the clutch housing.

4. Remove the brake pedal from the bike.

NOTE: Taking off the brake tip first can make removal easier.

5. Remove the exhaust spring to gain access the clutch housing bolt.

6. Lay the bike on its left side.

7. Using an 8 mm socket, remove the OE clutch housing. Pay close attention to the length and location of the OE screws so they can each be returned to the same location.

NOTE: *Rekluse recommends replacing the clutch housing gasket after reinstalling the clutch.*

8. Using a socket, remove the pressure plate screws and springs, then remove the pressure plate.

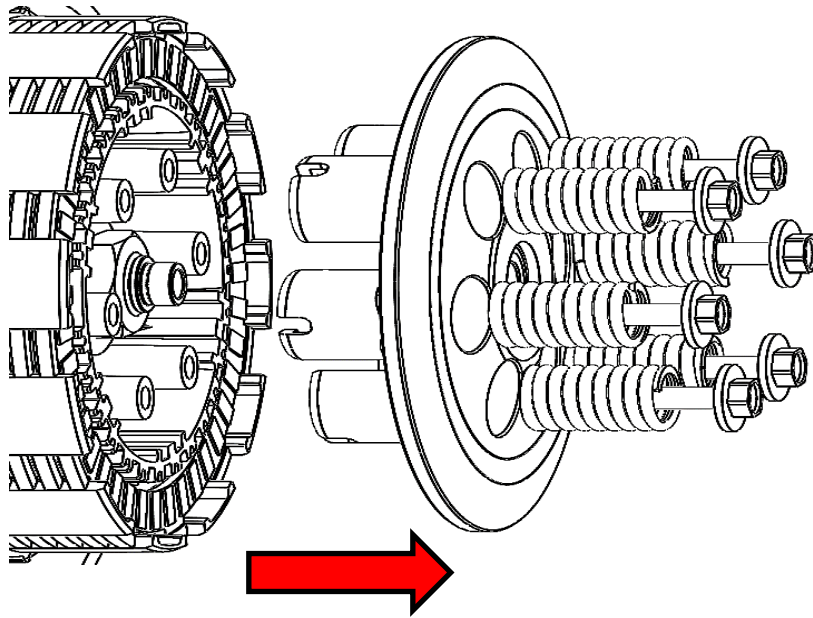

Note: *Your OE parts may look different than pictured*

9. Remove the OE clutch pack. Use a pick if necessary to help remove all of the plates.

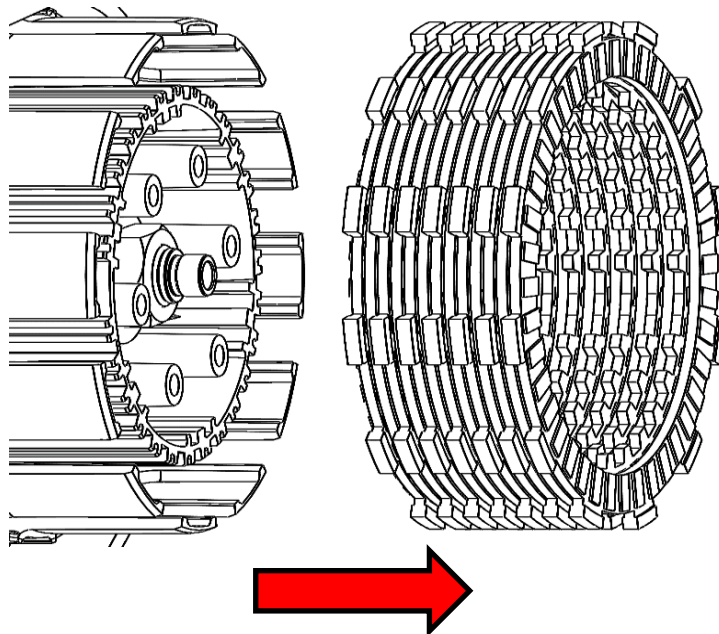

10. Remove the throw-out assembly, which typically includes a throw-out, needle bearing, and washer. Set this assembly aside. These parts will be reused.

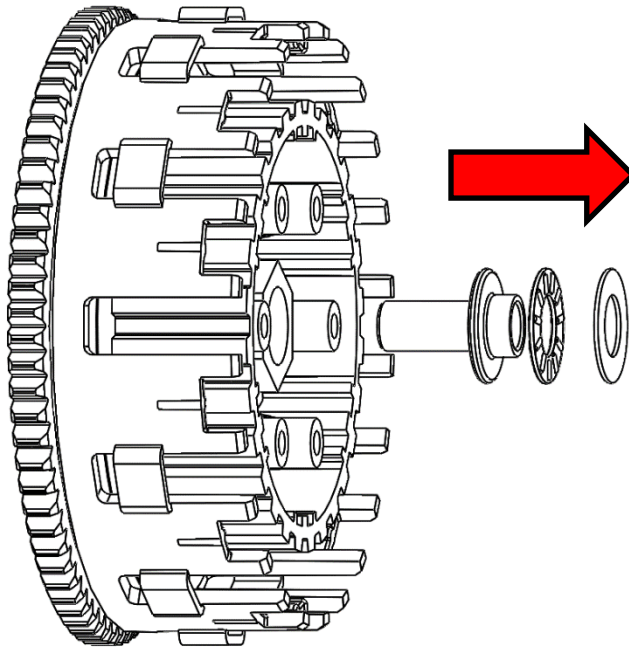

Note: *The throw-out assembly may look different depending on the bike.*

11. Use a hammer and a large screwdriver or chisel to bend down the edges of the washer tab until it clears the clutch nut.

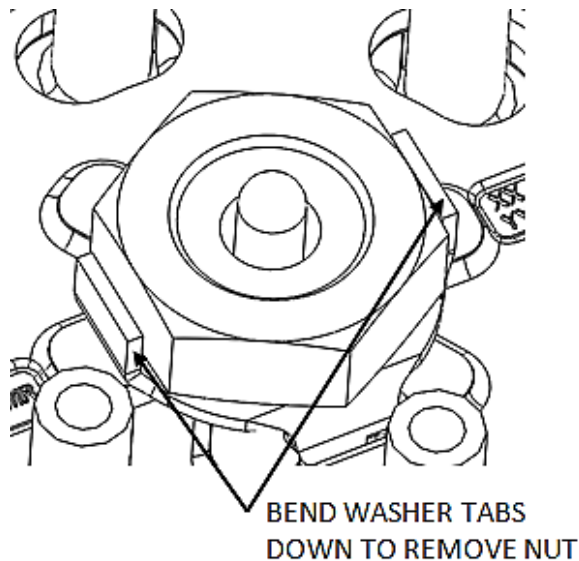

Note: *Some bikes use a Belleville spring instead of a tab washer. Skip step 13 if this is the case for your bike.*

12. Remove the center clutch nut with an impact wrench or breaker bar, and a socket. Set aside. The OE clutch nut will be reused.

Note: *Placing the bike in the highest gear and holding the rear wheel by applying the rear brake keeps the shaft from rotating when removing the nut.*

13. Remove the lock washer located under the center clutch nut. The OE lock washer will be replaced with a Rekluse tab lock washer.

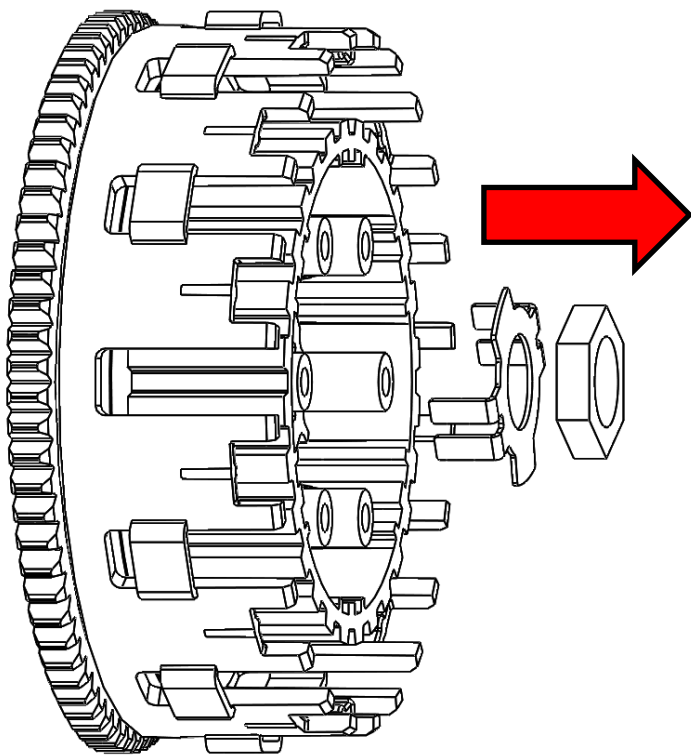

14. Remove the center hub and the clutch basket. Separate the thrust washer as it will be reused later.

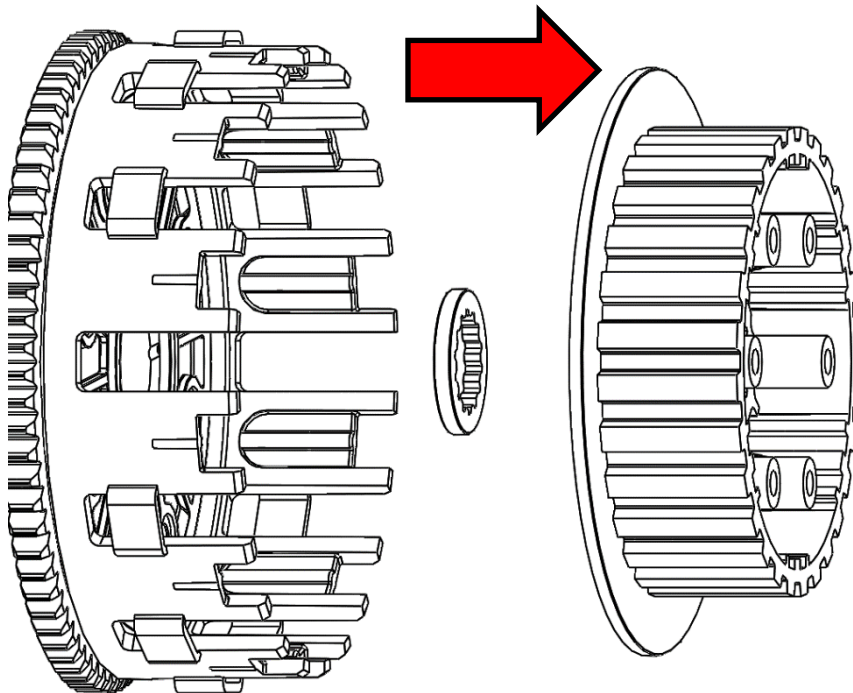

15.

Note: The OE thrust washer may be stuck to the bottom of the center hub assembly. The thrust washer must be installed or clutch performance issues will result.

BASKET OVERVIEW & DISASSEMBLY

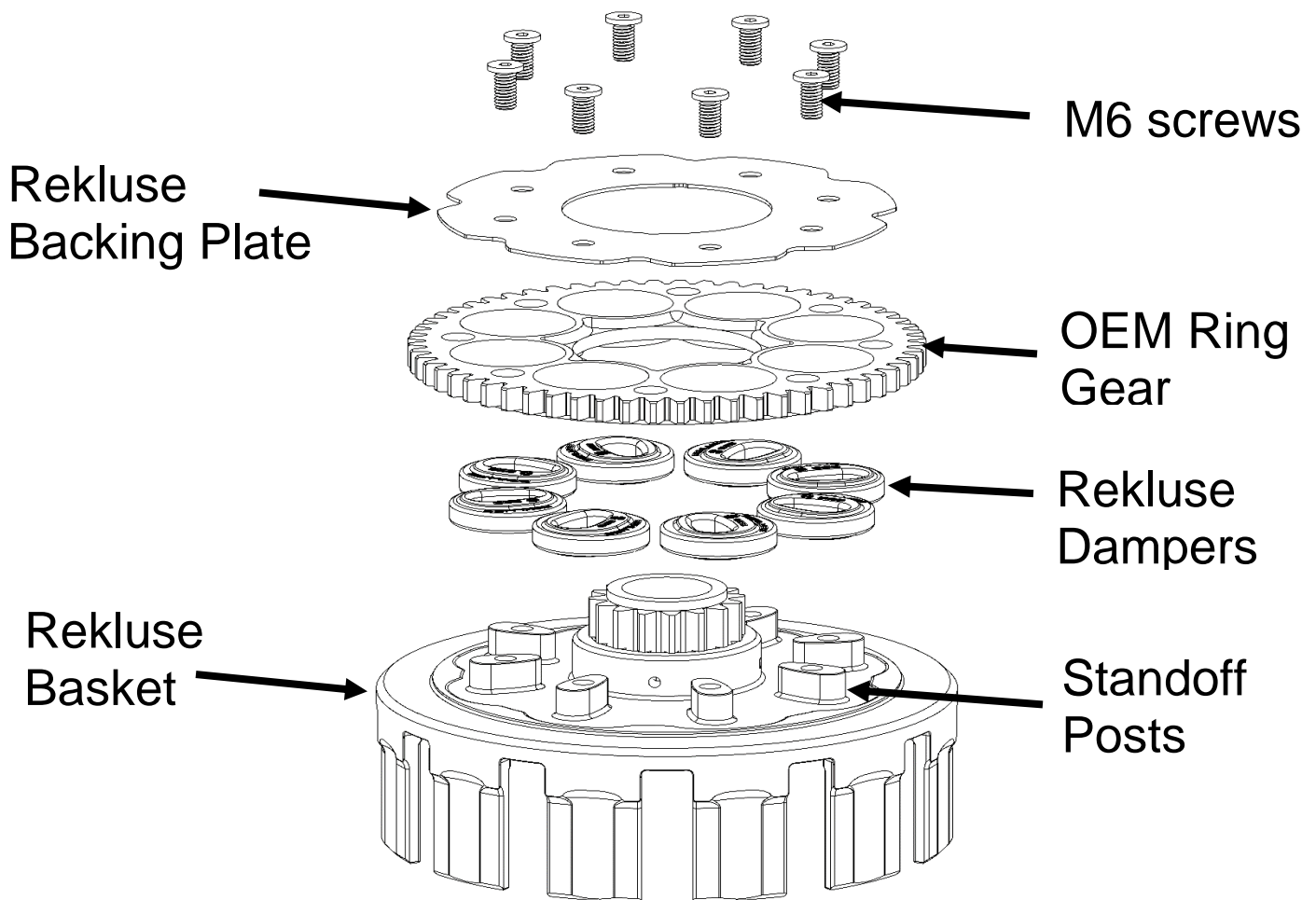

1. Set the OE basket on a hard surface with the ring gear facing upward. Using a center punch and hammer, punch a divot into the top of each rivet head, taking care to be on center.

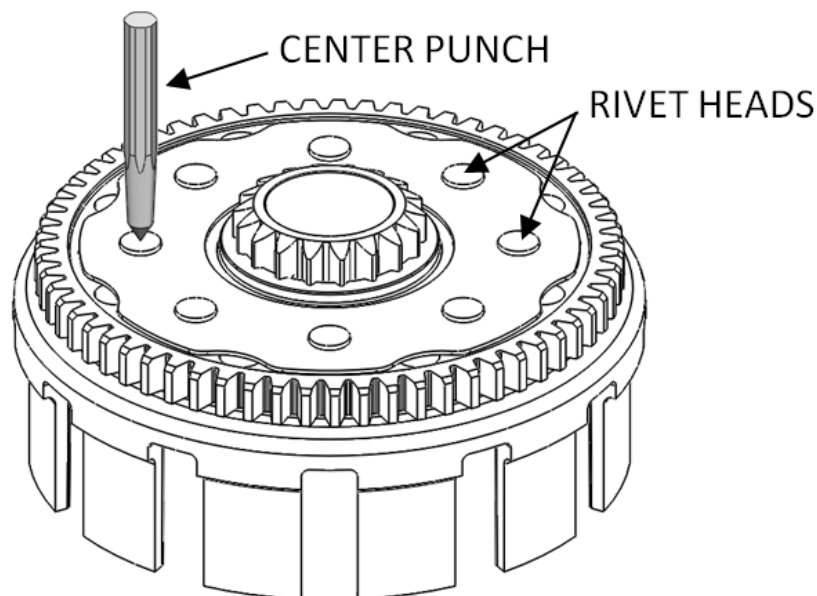

2. Use the supplied drill bit to drill out the heads of all the rivets. Set your drill to 300-400 RPM and use proper cutting fluid or oil for best results.

CAUTION

Drill only deep enough to pop the rivet head off. Do not damage the steel ring gear; it will be reused.

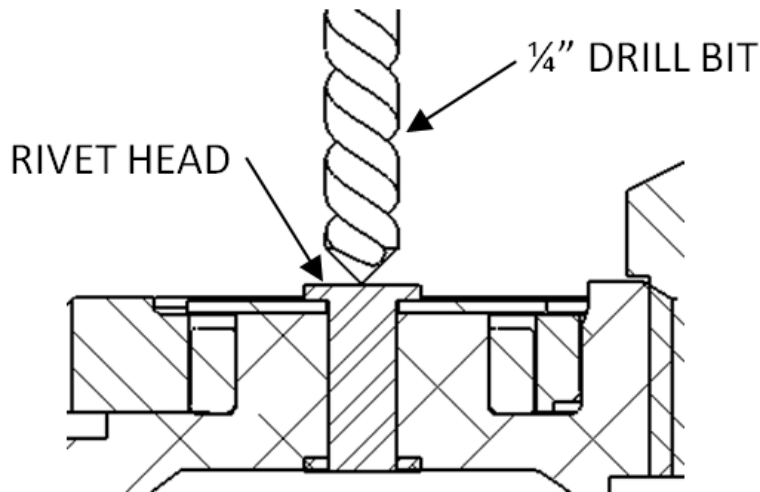

3. Carefully pry the OE backing plate off the basket and remove the OE ring gear.

Basket Assembly

1. Add some engine oil to the new Rekluse dampers and install one per standoff post to the Rekluse basket.

⚠ CAUTION

Failure to install dampers in the correct orientation can result in excessive clutch and transmission wear. Dampers should be oriented as shown in the image below.

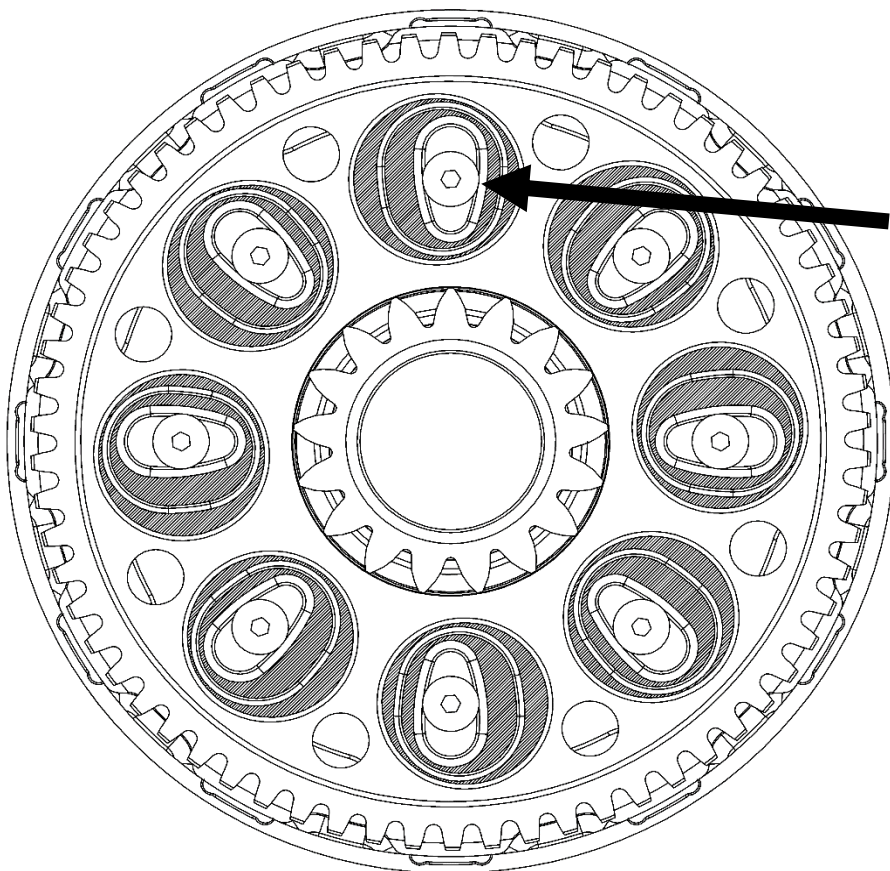

Starting from the top install dampers with the thick side of the damper to left of the standoff and logo facing up

2. Reinstall the OE ring gear. The ring gear may fit snugly and will likely require using a soft mallet to tap it on until it seats all the way against the basket.

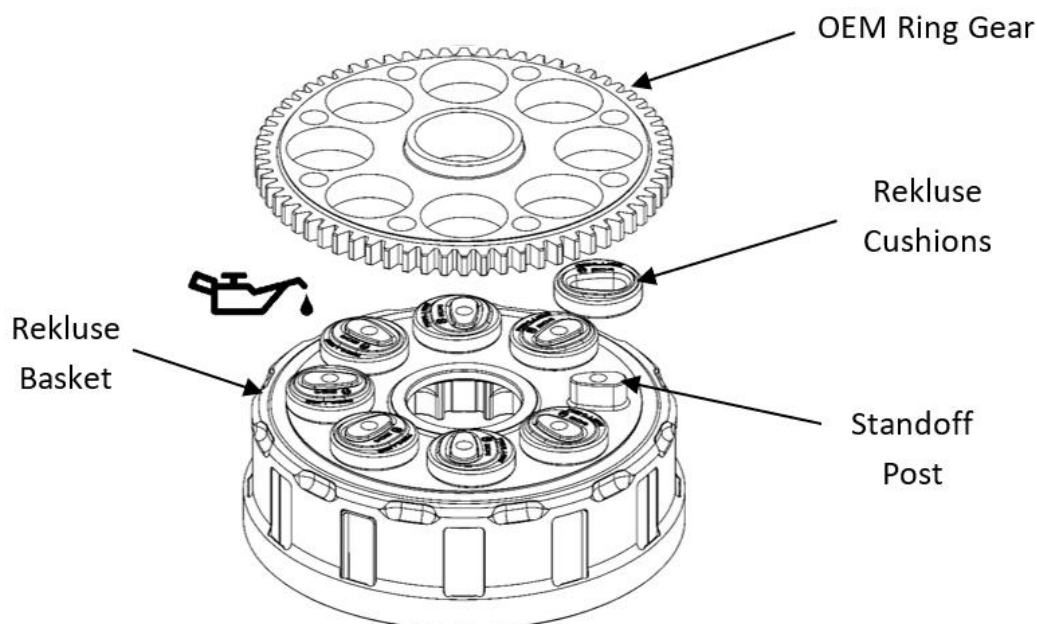

3. Install the Rekluse backing plate, then apply the supplied Loctite 262 to each of the M6 screws before threading them into the clutch basket assembly.
4. Tighten to **80 in-lb (9 N-m)** in a crisscross pattern to compress the assembly evenly.

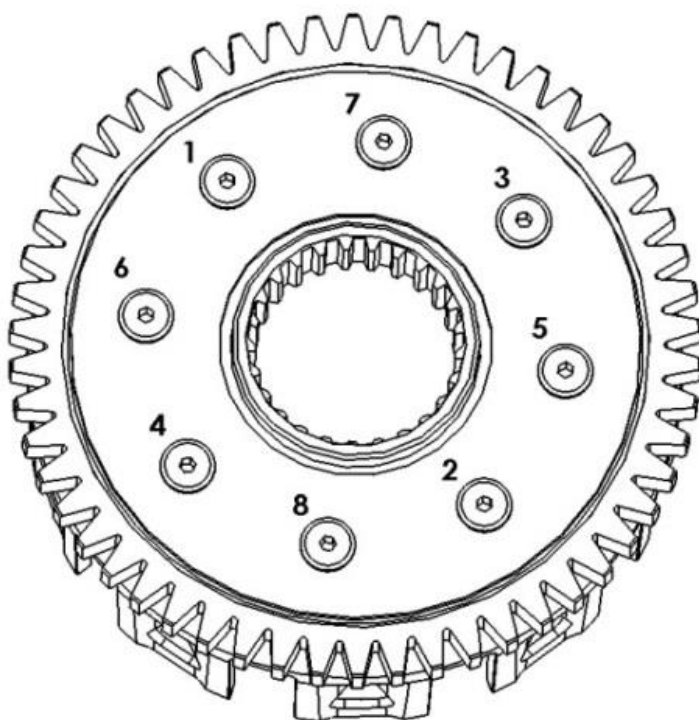

5. Turn the basket over on the workbench.

- Using a hammer and center punch, peen the ends of the screws where they come through the bottom-inside of the clutch basket.

⚠ CAUTION

Be sure to peen only the screws. **DO NOT** peen the aluminum basket.

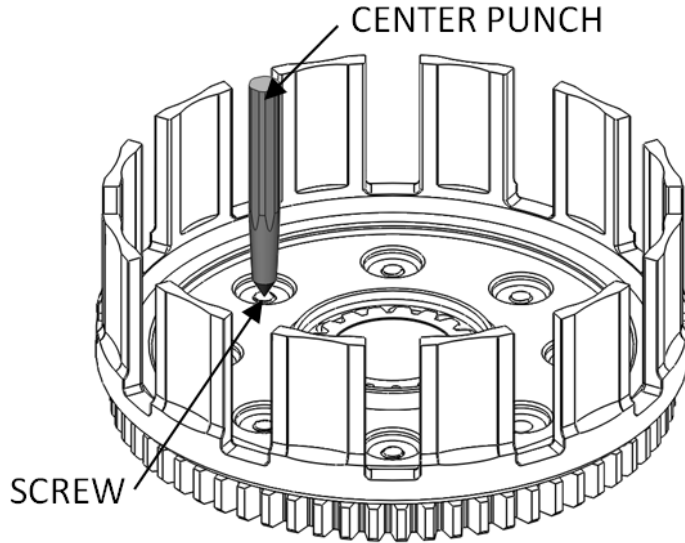

⚠ WARNING

It is **critical** that you apply Loctite and peen the ends of the screws or they can back out. Rekluse is not responsible for engine damage caused by screws that back out.

- Install the new clutch basket assembly into the engine ensuring the ring gear is properly aligned and the basket fully seats.

Note: Some ring gears have a groove that indexes to a protrusion on the oil pump gear. Be sure to clock the basket so these features index properly if they are present.

Oil pump
Gear
protrusion

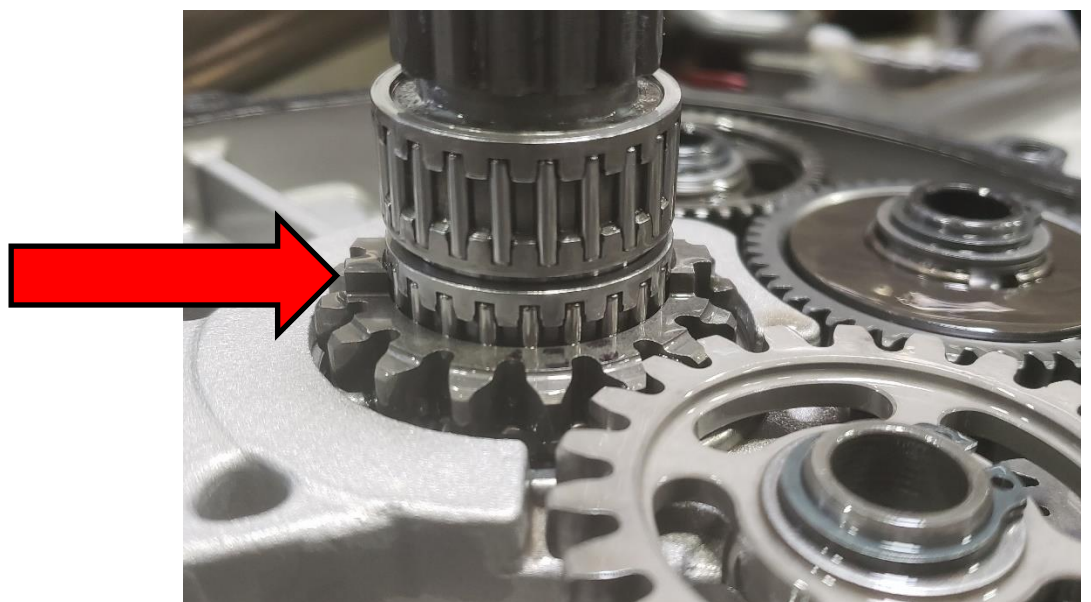

INSTALL THE HUB

1. Install the OE thrust washer on the main shaft against the basket

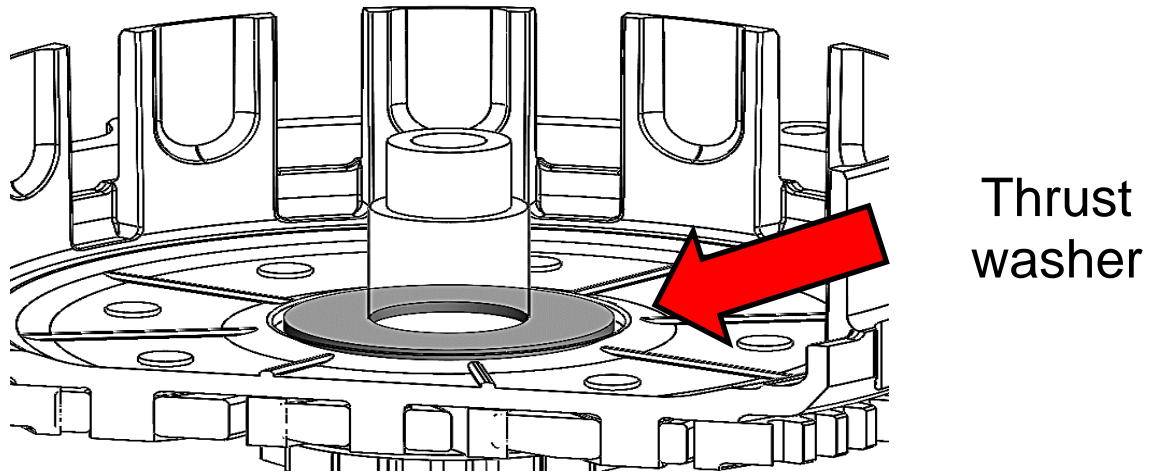

2. Install the new Rekluse center hub into the clutch basket.

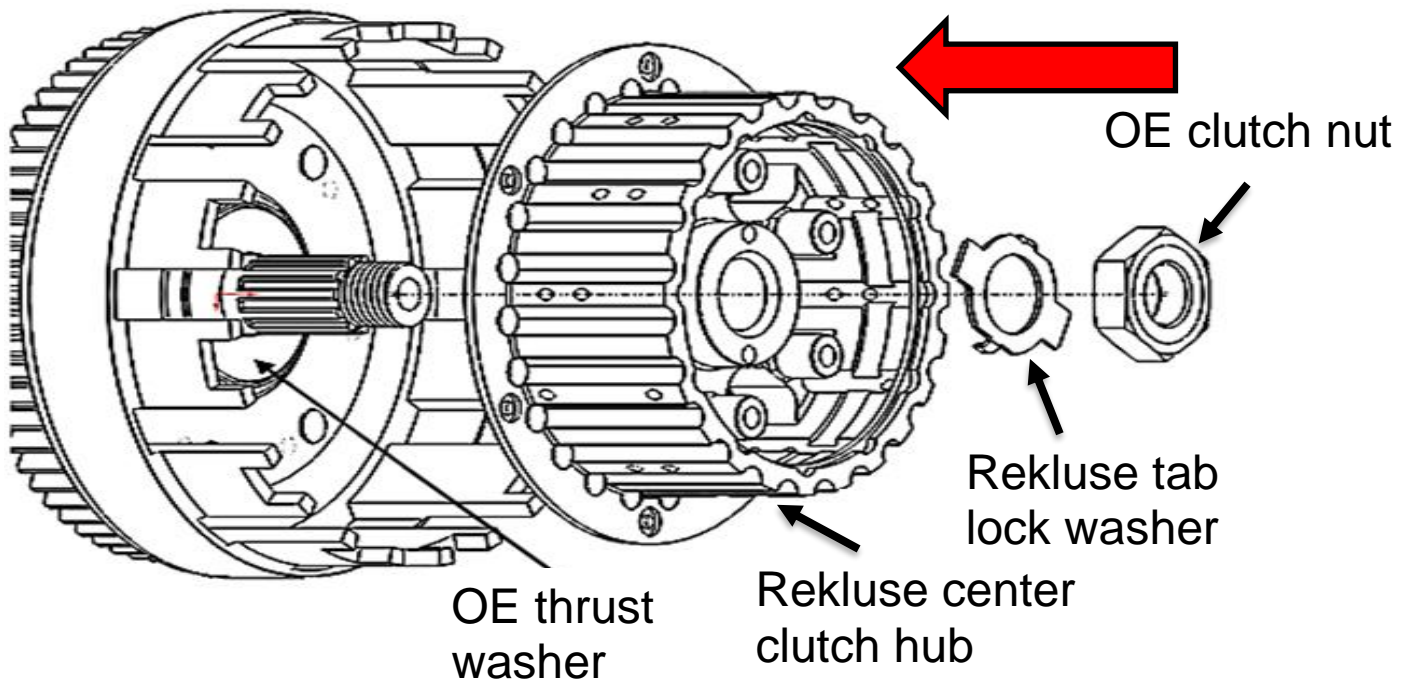

3. Install the new Rekluse tab washer with the bent tabs facing down, aligning with the holes in the hub. *Only use the supplied lock tab washer under the OE center clutch nut when installing the hub.*

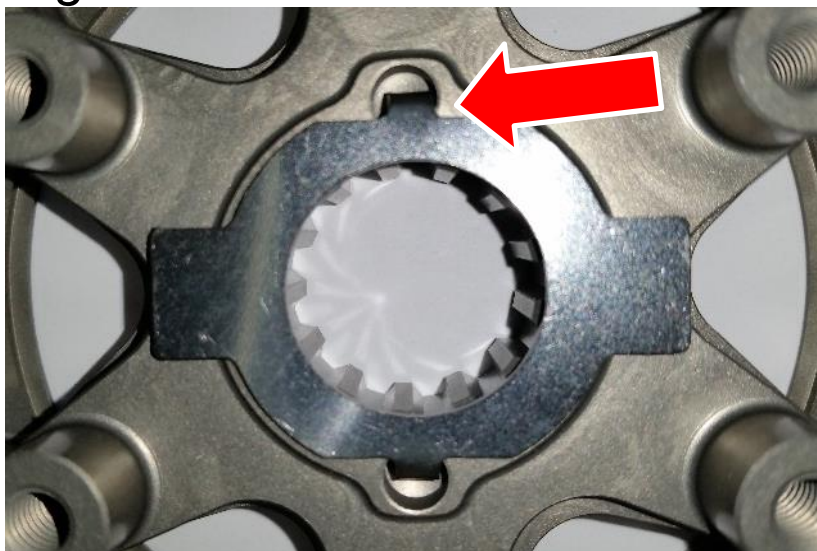

4. Install the OE center clutch nut.

5. Using a socket and torque wrench, torque the center clutch nut to **73 ft-lb (100 N-m)**.

Note: *Placing the bike in the highest gear and holding the rear wheel by applying the rear brake keeps the shaft from rotating when tightening the nut.*

6. Using the channel-lock pliers, bend up **both** tabs of the tab washer tightly around the nut. The tabs can be bent on the straight sides or around the corners.

7. Reinstall the OE throw-out assembly (including the bearing and washer). If the throw-out washer is missing, check to see if it is stuck to the underside of the OE pressure plate.

INSTALL THE CLUTCH PACK

1. Soak the provided friction disks in new oil for at least 5 minutes.

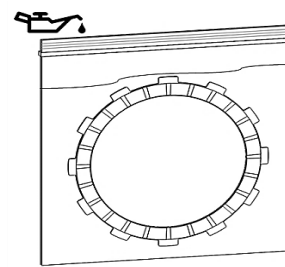

2. Install the Rekluse clutch pack starting with a steel drive plate, then install a friction disk.

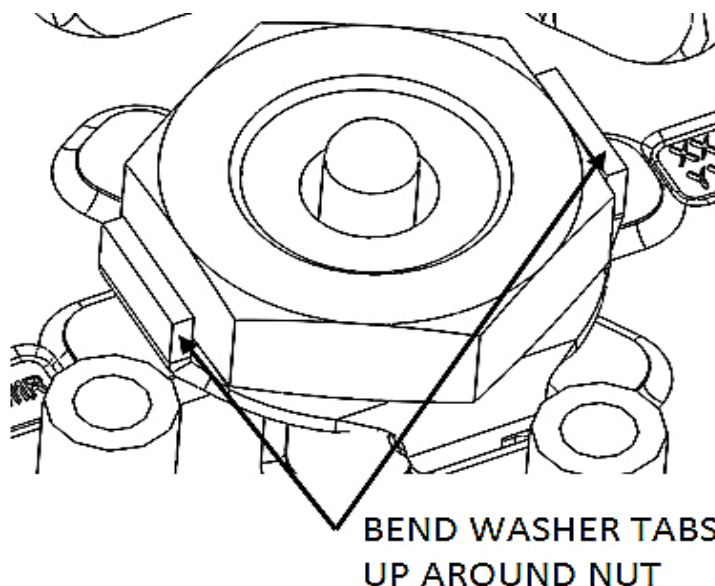

3. Continue to alternate steel drive plates with friction disks for the entire clutch pack. *The last plate installed is a steel drive plate.*

Note: *The total number of steel drive plates and frictions depends on the bike model. Refer to the Setup Sheet for Clutch pack order and height information.*

4. Install the pressure plate.

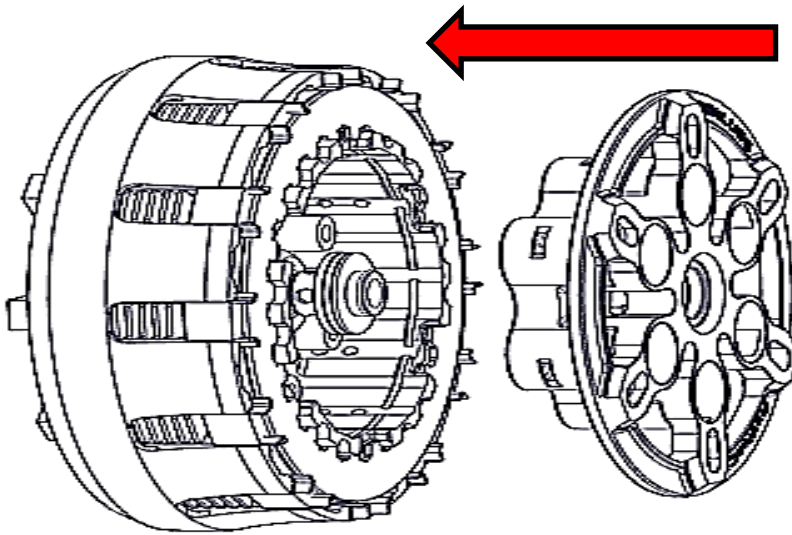

5. Install the Rekluse pressure plate springs.

Pressure Plate Spring Information

Do not use higher force pressure plate springs than those included in the kit. Charts are representative. Differences in clamping force and torque capacity will vary by model. Spring force is directly related to torque capacity. See the chart and bullets below for more information.

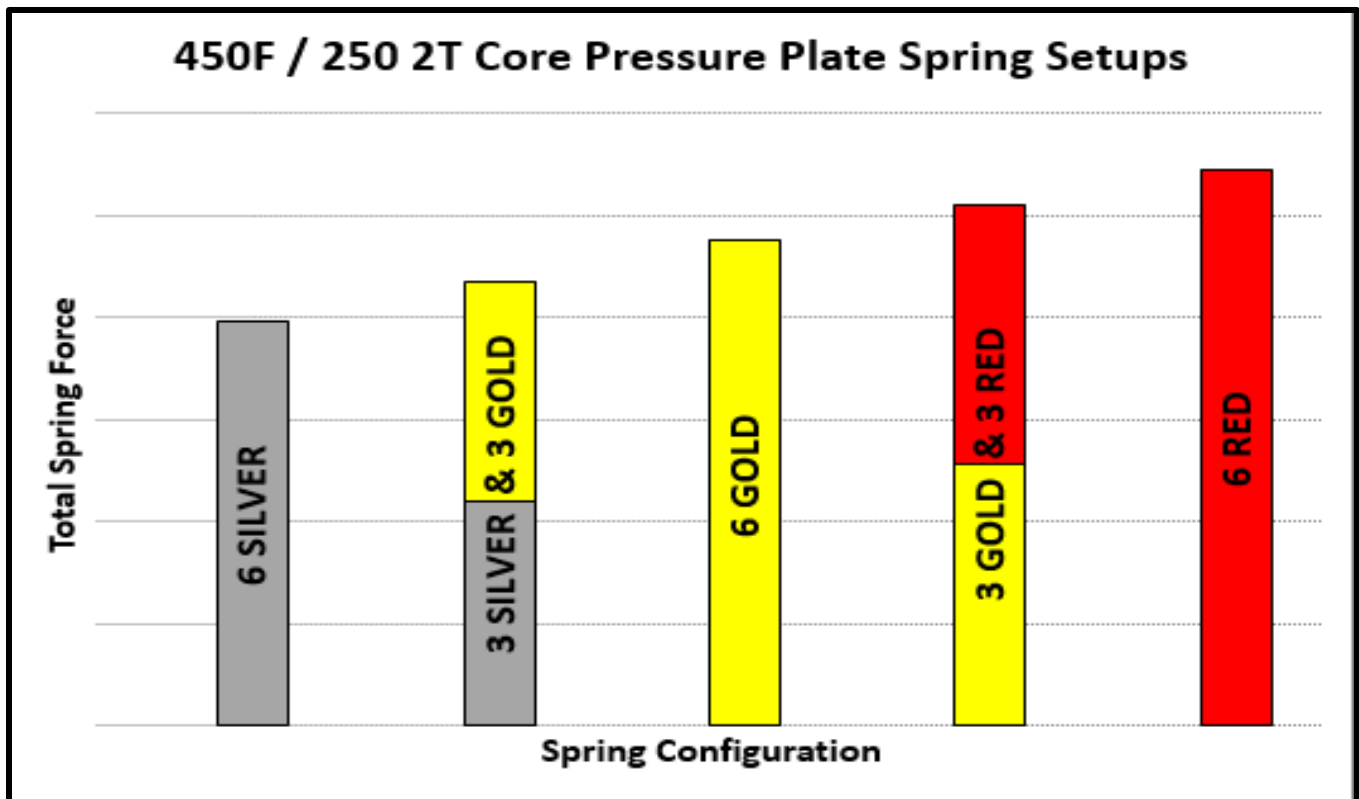

There are three configuration options included in your spring kit.

- A lower force spring setting (see chart) will give the feel of a smoother clutch with a clutch lever pull that is much lighter than stock. The higher force spring setting will yield a more aggressive clutch with clutch pull similar to stock.

- Be sure to alternate springs when using 3 & 3 to keep even pressure on the clutch pack.
- For the highest performance and best clutch pack life, the configuration with the highest spring force is recommended.
- Heavier springs options are available from Rekluse if desired

6. Install the screw sleeves and socket head cap screws.

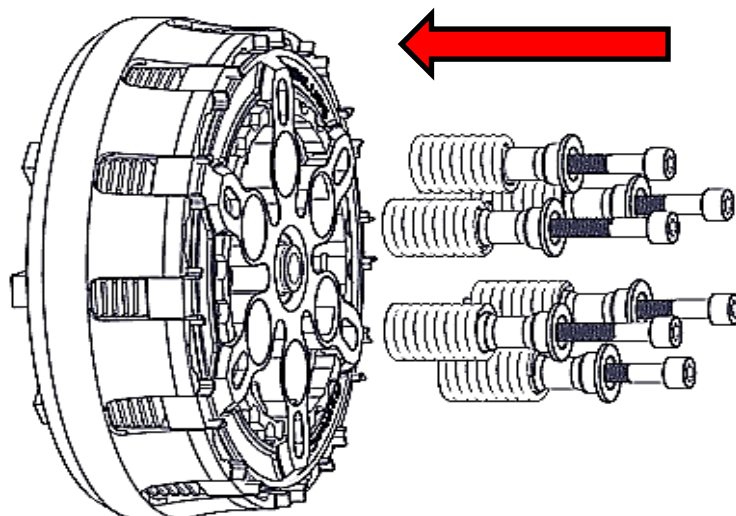

⚠ CAUTION

Do not reuse the OE springs, washers, or bolts!

7. Use a torque wrench and socket to torque the cap screws by lightly tightening the screws in small increments. Torque the cap screws to **9 ft-lb (12 N-m)**.

FINISH INSTALLATION

1. Install the clutch housing.
2. Install the clutch cover gasket and the Rekluse clutch cover.

3. Reinstall the clutch cover bolts, then lightly tighten the cover bolts in small increments in a star pattern. Torque the cover bolts to OE specifications.

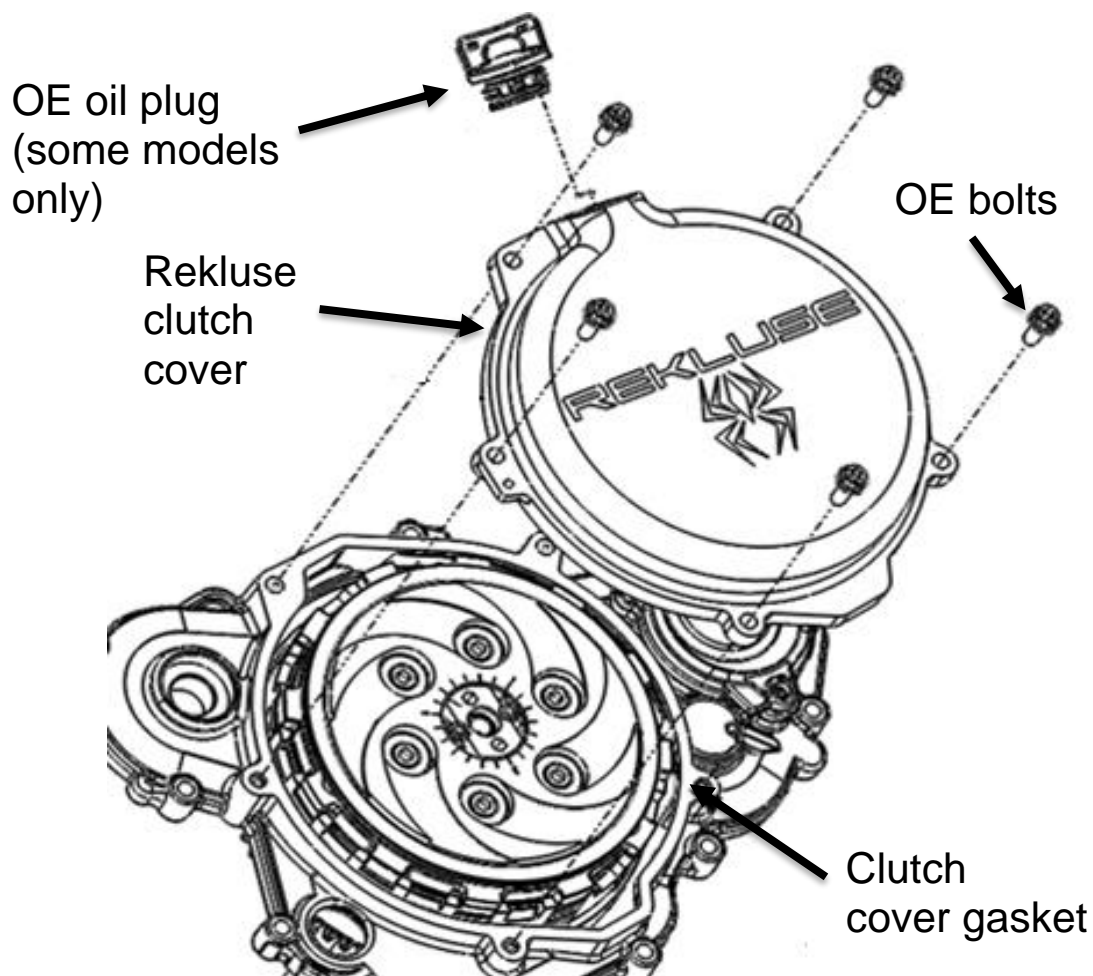

4. Reinstall the rear brake, exhaust spring, and water pump.

5. Refill with radiator with coolant.

BREAK IN

Break-in will occur over the first 1-2 hours of use, depending on the rider. During break-in more clutch drag may occur than normal.

MAINTENANCE

- Inspect all of your clutch parts at regular maintenance intervals for signs of wear or excessive heat, and replace components as necessary. Clutch wear is very dependent on the riders use, inspection interval may vary.
- Keep up with regular oil changes and other bike maintenance. Ultimately, better clutch longevity and performance is greatly increased with oil quality and other bike factors that reduce engine heat.
- Replace friction disks regularly for best clutch component life, especially if they appear glazed and/or burnt upon inspection.

Basket

Rekluse baskets are built using high quality materials but do wear based on the rider's use, type of terrain, and natural wear and tear.

- To keep your clutch basket performing at its best, perform regular maintenance on your bike and inspect your components regularly.
- Inspect the clutch basket for notching. Notched basket tang faces can cause performance issues. The basket should also be inspected for any fatigue cracking at the tang bases. Replace basket if necessary.

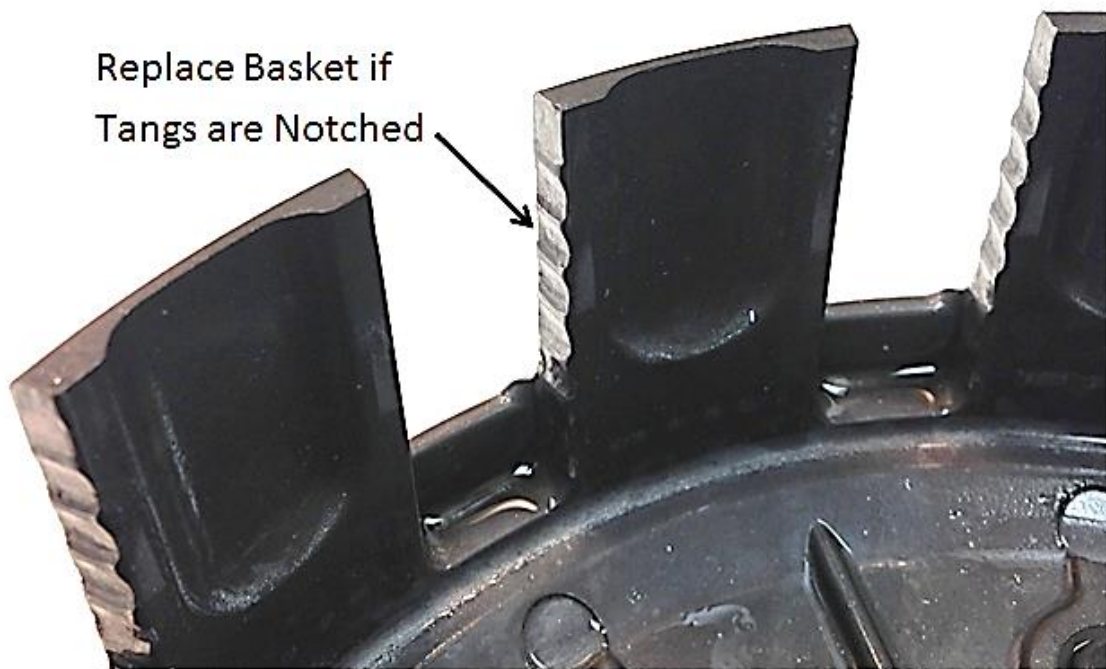

- Do not use baskets that have been filed, machined, or modified on the tangs.

Dampers

The dampers inside the basket assembly shrink due to heat and use. This is a normal wear item and should be inspected periodically. Any movement between the dampers will shorten the life of your inner hub and accelerate basket wear.

- Inspect the basket dampers and/or springs by checking the play between the ring gear and the basket. Replace the dampers/springs if you feel any play in the assembly.
- Inspect the dampers if your inner hub is notched. This is usually a sign that the dampers need to be replaced.

To inspect the dampers:

1. Remove the basket from the engine, hold the ring gear in one hand and the basket in the other, then twist in opposite directions. The rotational play is sometimes accompanied by an audible “click” sound when rotating back and forth.

If any rotational play can be felt between the basket and the ring gear, the dampers are worn and either the dampers and/or basket assembly need to be replaced.

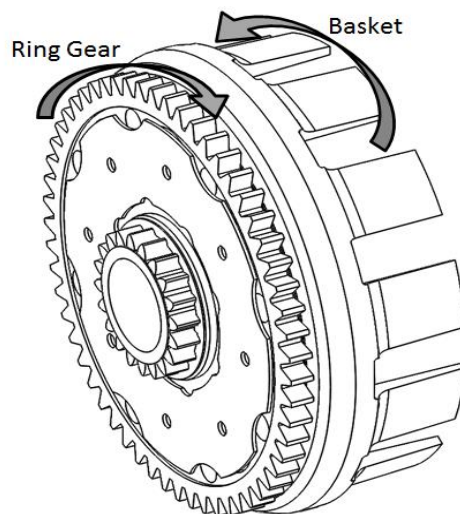

NEED ADDITIONAL HELP?

Website

www.rekluse.com/support

Frequently Asked Questions

www.rekluse.com/faq

Support Videos

www.rekluse.com/support/videos

Phone

(208) 426-0659

Technical Support

Contact Technical Support for questions related to product installation, tuning, and performance.

Hours:

Monday thru Friday: 8:00 a.m. - 5:00 p.m.

Mountain Time zone

Email: tech@rekluse.com



SETUP SHEET 198-7108011

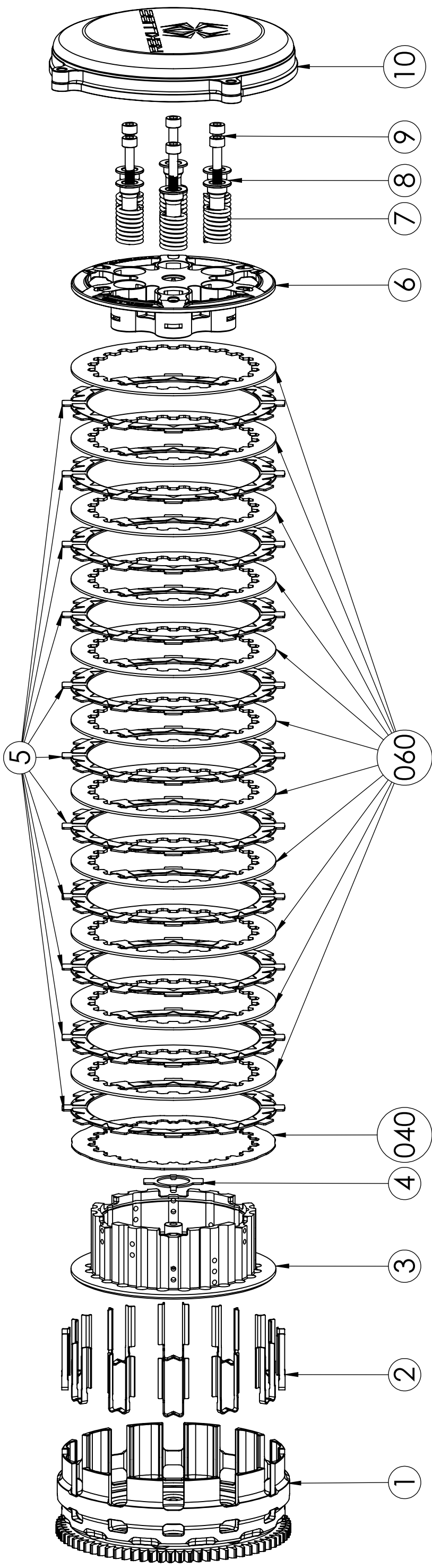

SERVICE LIMITS

COMPONENT	STANDARD	SERVICE LIMIT
TORQDRIVE FRICTION	.068-.072in 1.73-1.83mm	.065in 1.65mm

COMPONENTS

ITEM NO.	DESCRIPTION	QTY.
1	REKLUSE BASKET	1
2	BASKET SLEEVE	12
3	CENTER CLUTCH	1
4	LOCK TAB WASHER	1
5	TORQDRIVE FRICTION 0.070" (1.78mm)	11
6	PRESSURE PLATE	1
7	PRESSURE PLATE SPRING	6
8	SCREW SLEEVE	6
9	PRESSURE PLATE SPRING	6
10	CLUTCH COVER	1
040	JUDDER DRIVE PLATE 0.040"(1mm)	1
060	DRIVE PLATE .060" (1.5mm)	11

CLUTCH PACK THICKNESS

