



INSTALLATION & USER'S GUIDE

CoreManual TorqDrive® for KX450 and KX250
2021+ Bike Models

Doc ID: 191-7147A
Revision: 110821

©2021 Rekluse Motor Sports
Rekluse Motor Sports, Inc.
customerservice@rekluse.com

Table of Contents

OVERVIEW	2
INSTALLATION TIPS	3
TOOLS NEEDED.....	4
INCLUDED PARTS	4
CLUTCH REMOVAL	5
HUB INSTALLATION	8
CLUTCH PACK INSTALLATION.....	9
PRESSURE PLATE INSTALLTION	10
SPRING OPTIONS.....	11
CLUTCH COVER INSTALLATION.....	13
BREAK-IN.....	14
MAINTENANCE.....	14
NEED ADDITIONAL HELP?.....	15

OVERVIEW

This kit replaces OE (Original Equipment) or “stock” core clutch components with high-quality billet components designed for optimal performance specific to your bike.

- The OE frictions and drive plates are replaced with Rekluse drive plates and TorqDrive® frictions
- The OE center clutch hub and pressure plate are replaced with Rekluse Core components

INSTALLATION TIPS

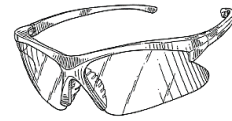

- Read the separate included Safety Information document before operating the vehicle with the product installed.
- Read this entire document before performing any steps.
- If you install this product for a customer or another person, instruct them to read the **Safety Information** document and the **Installation and User Guide** before operating the vehicle with the product.
- Protect eyes and skin – wear safety glasses and work gloves.
- Lay the bike on its left side when replacing the clutch. This makes working on the clutch easier and eliminates the need to drain the oil.
- Use an air or electric impact wrench to remove the center clutch nut. If one is not available, you can place the bike in top gear and hold the rear brake while loosening the center clutch nut with a socket and breaker bar.
- Channel-lock pliers work best to bend the tabs of the washer up over the center clutch nut.
- For optimal clutch performance, Rekluse recommends using fresh, clean oil that meets JASO-MA oil rating requirements. Rekluse offers Factory Formulated Oil™ developed specifically for Rekluse products. Rekluse Factory Formulated Oil is a perfect complement to any OEM or aftermarket wet clutch. Visit www.rekluse.com to learn more.
- Use the torque values listed in the instructions. Otherwise, use the torque specifications found in your OE service manual.

TOOLS NEEDED

- Socket set (8, 10, and 30 mm)
- Channel-lock pliers
- Hammer
- Torque wrench (in-lb & ft-lb, or N-m)
- Flat head screwdriver
- Hex key (4 and 5 mm)

INCLUDED PARTS

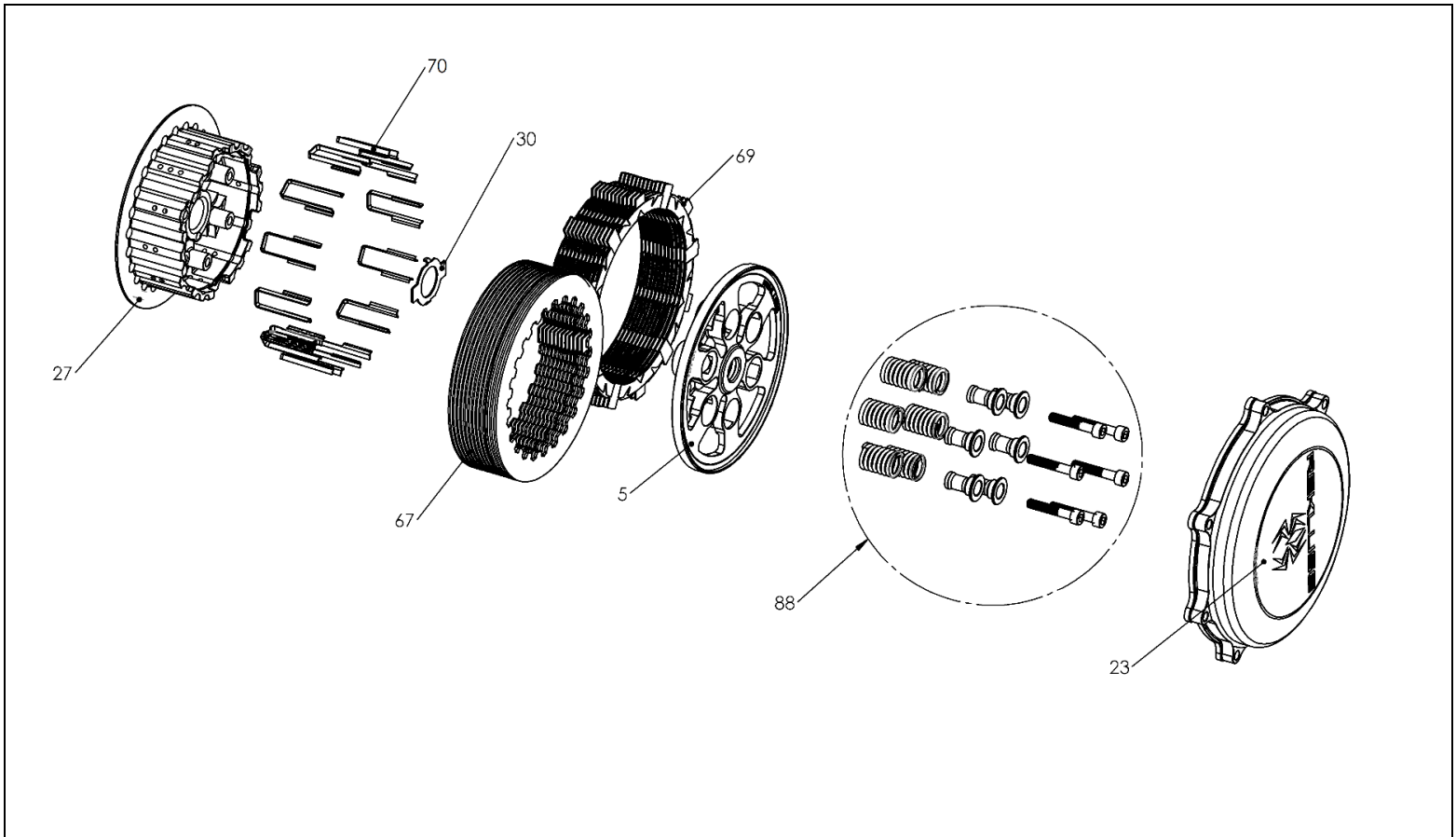

Item	Description
5	Pressure plate
23	Clutch cover
27	Center clutch hub
30	Lock-tab washer
67	Steel drive plates
69	TorqDrive® friction disks
70	Basket sleeves
88	Clutch spring assembly

Parts and quantities may vary by model. View the included **Setup Sheet** and visit www.rekluse.com/support for a full parts fiche illustration and part numbers.

CLUTCH REMOVAL

1. Lay the bike on its left side. Catch any fuel that might drain in a suitable container.
2. Loosen the oil plug before removing the clutch cover.
3. Remove the OE clutch cover.
4. Remove the following OE parts from the clutch basket.

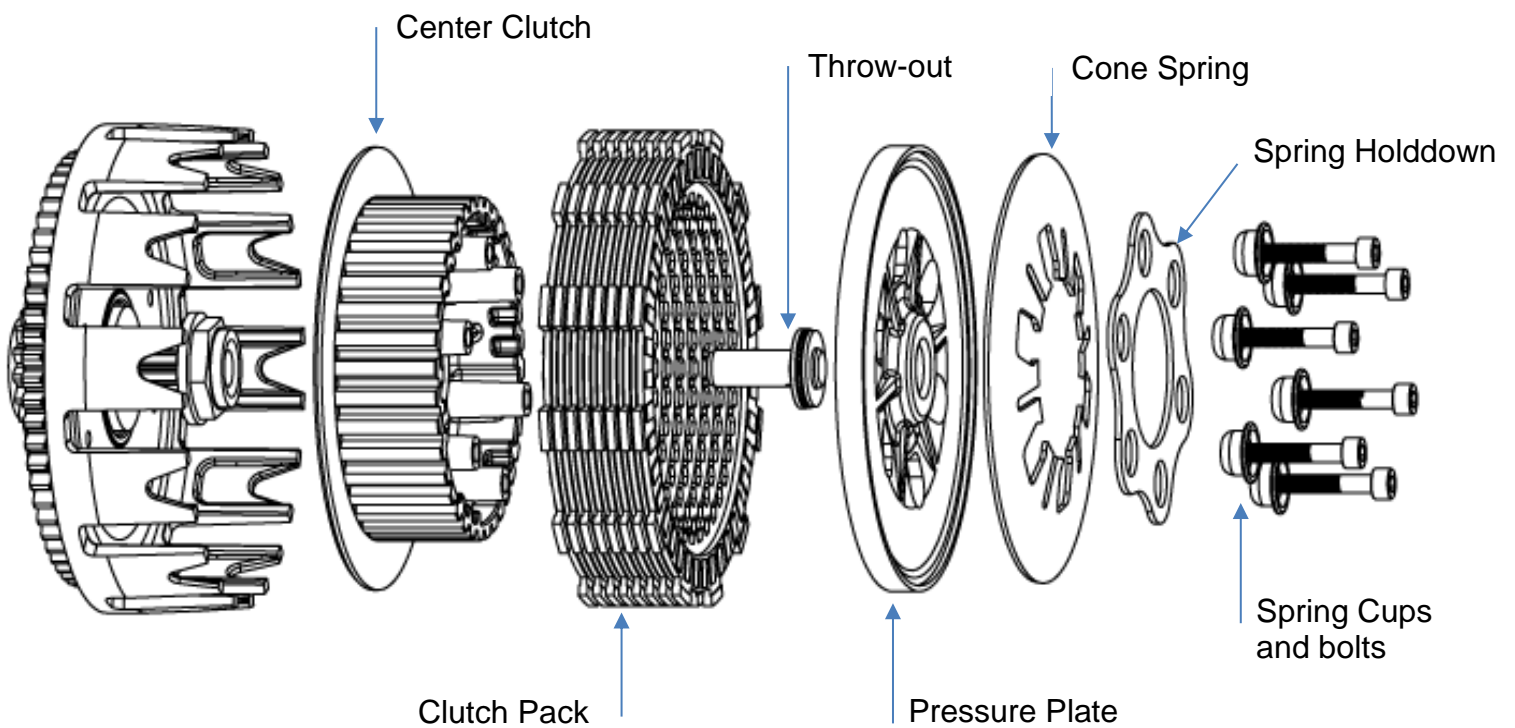

5. Inspect the clutch basket for damper/cushion play or notching. Do not install sleeves or use products with a notched basket. Notched basket tang faces or worn dampers can cause the sleeves to break.

⚠ WARNING

Failure to inspect the basket and replace if necessary could result in death, serious injury, and/or property damage.

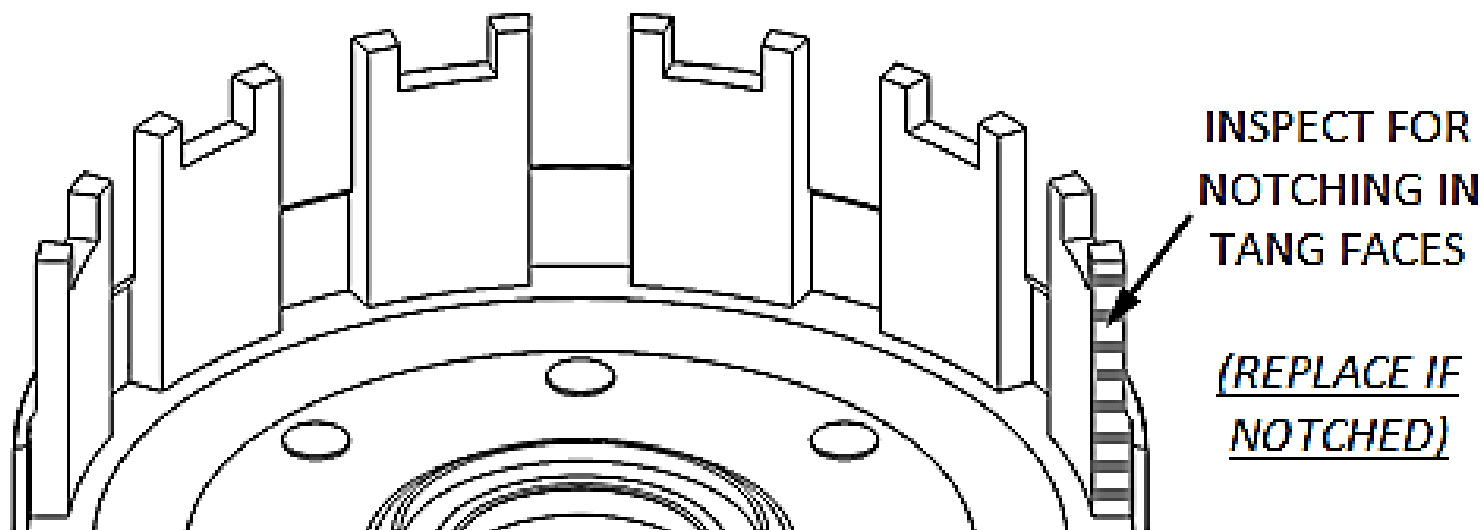

⚠ WARNING

Rekluse basket sleeves are designed to be installed into an OE or Rekluse clutch basket **ONLY**. The use of non-Rekluse aftermarket clutch baskets may cause clutch damage or failure.

Note: *If the basket is notched or worn, Rekluse recommends replacing it with a Rekluse Billet Clutch Basket (available for most models).*



6. Install **ALL** the Rekluse basket sleeves into the basket slots. Make sure the sleeve tabs sit against the inside of the basket, then push the sleeves down until they contact the bottom of the tang slot. See pictures for reference.

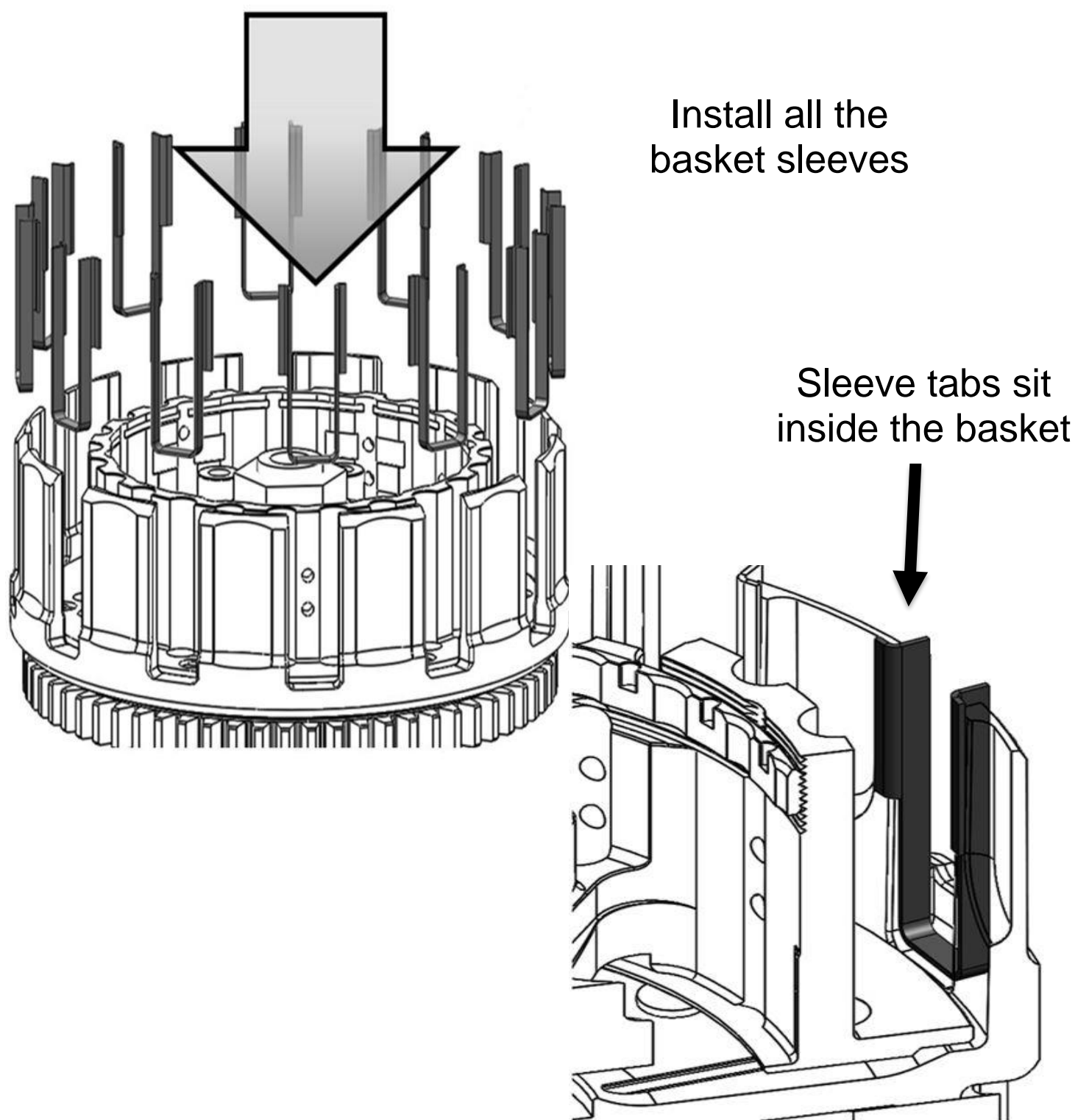

Note: *If the basket sleeves fall forward while installing the clutch pack, use a pick to push them back into place. When seated in the basket, the sleeves may stick above or below flush with the top of the basket depending on the bike model. This is normal.*

HUB INSTALLATION

1. Install the new Rekluse center hub assembly into the clutch basket. *Make sure the thrust washer is on the main shaft before installing.*

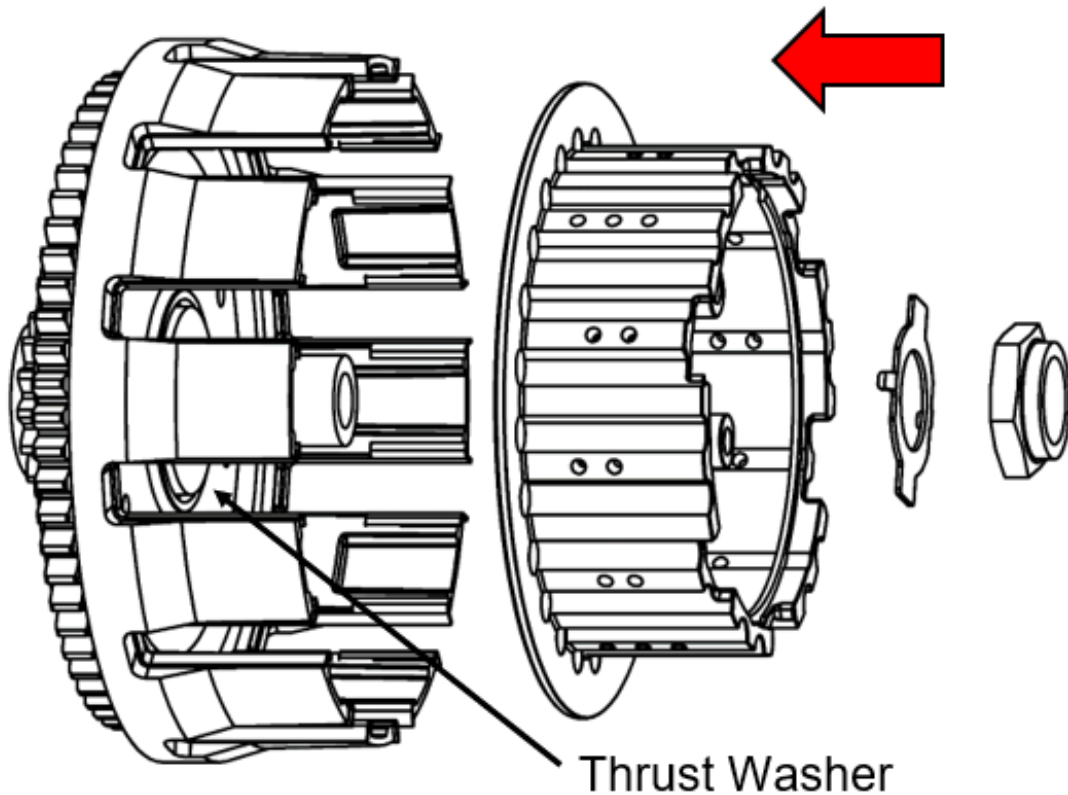

2. Install the new Rekluse tab lock washer and OE center clutch nut, then torque the nut to **70 ft-lb (95 N-m)**.

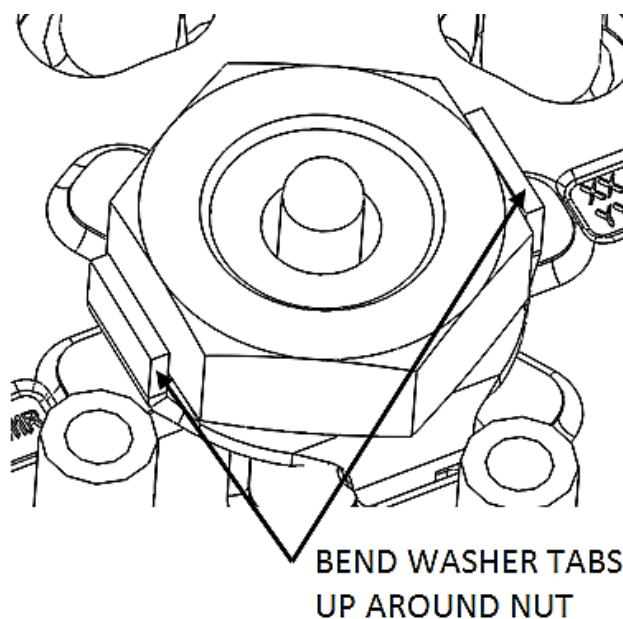

3. Using the channel-lock pliers, bend up **both** tabs of the tab washer tightly around the nut. The tabs can be bent on the straight sides or around the corners.

CLUTCH PACK INSTALLATION

Note: Some friction disks are marked with a small colored dot. This mark is used for processing and can be ignored.

Note: Some OE baskets have “half slots” at the top of the basket tangs. Rekluse products require the entire clutch pack to be installed into the MAIN (deeper) basket slots. Installing the pack in the “half slots” will cause performance issues. See the following picture for reference.

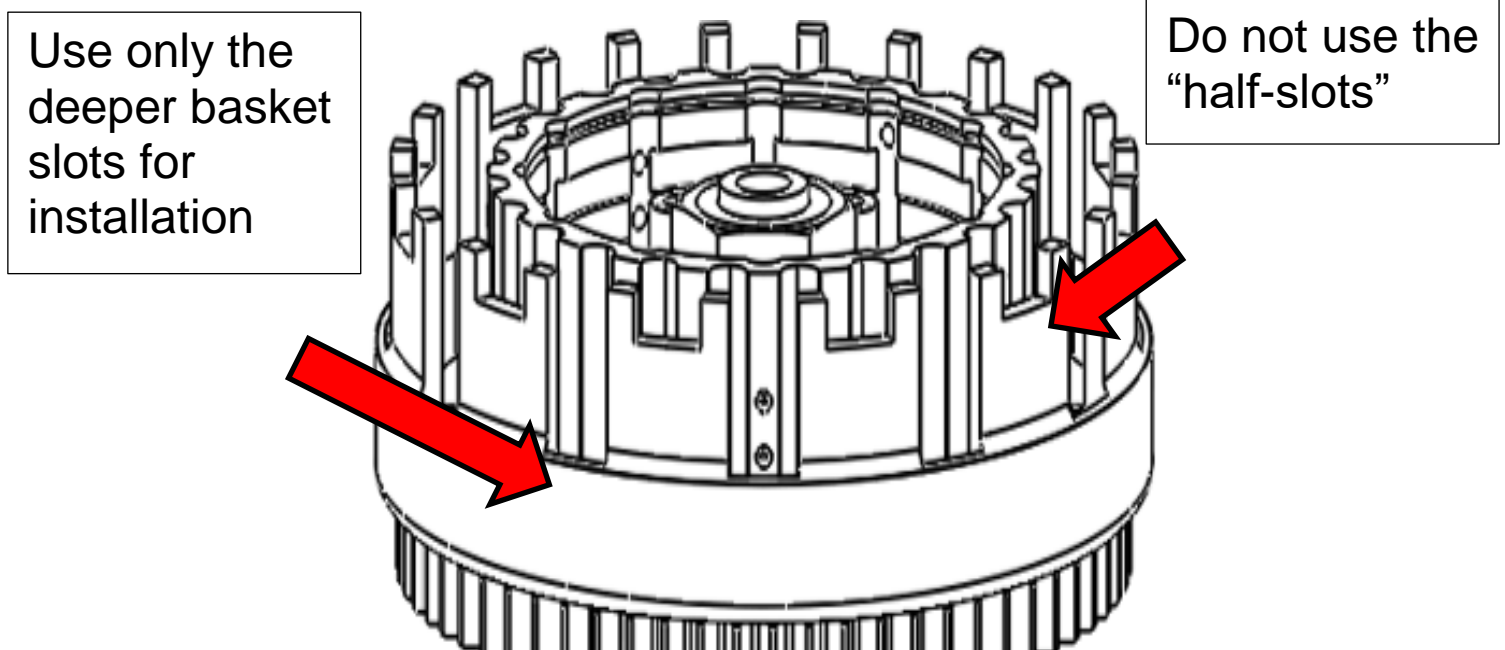

1. Soak the Rekluse friction disks in engine oil for at least 5 minutes. Make sure the friction disks are coated on both sides.

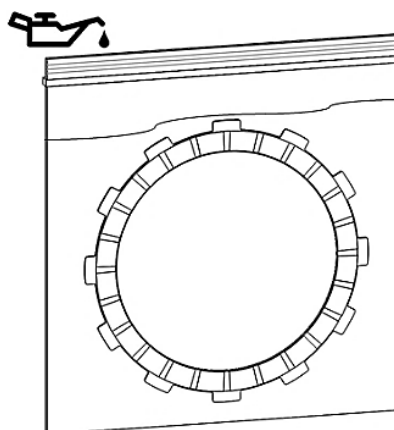

2. Install the Rekluse clutch pack according to the included **Setup Sheet**
3. Install the throw-out assembly (throw-out, bearing, and washer).

PRESSURE PLATE INSTALLTION

4. Install the Rekluse pressure plate onto the clutch pack.
5. Install the Rekluse coil springs, screw sleeves, and pressure plate screws.

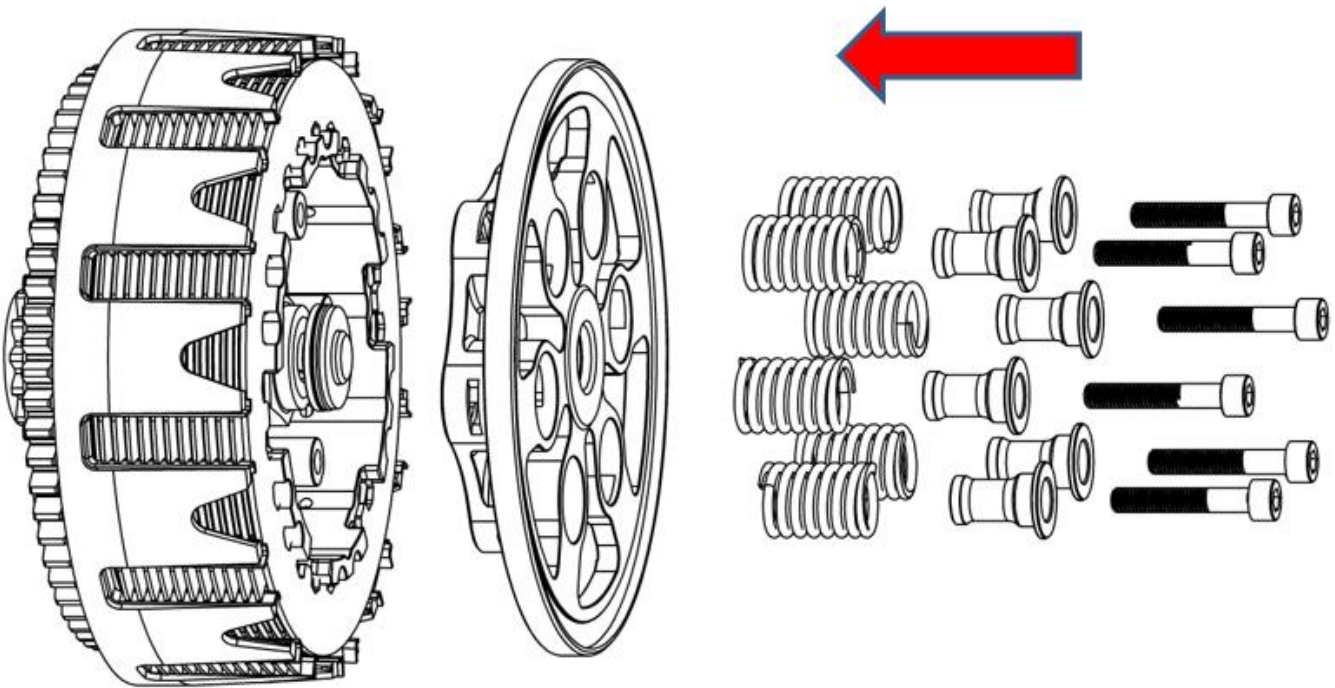

Note: The screw sleeves sit higher than the top of the pressure plate (see image below). This is normal. Ensure that the springs and screw sleeves are installed correctly and the bolts are torqued properly.

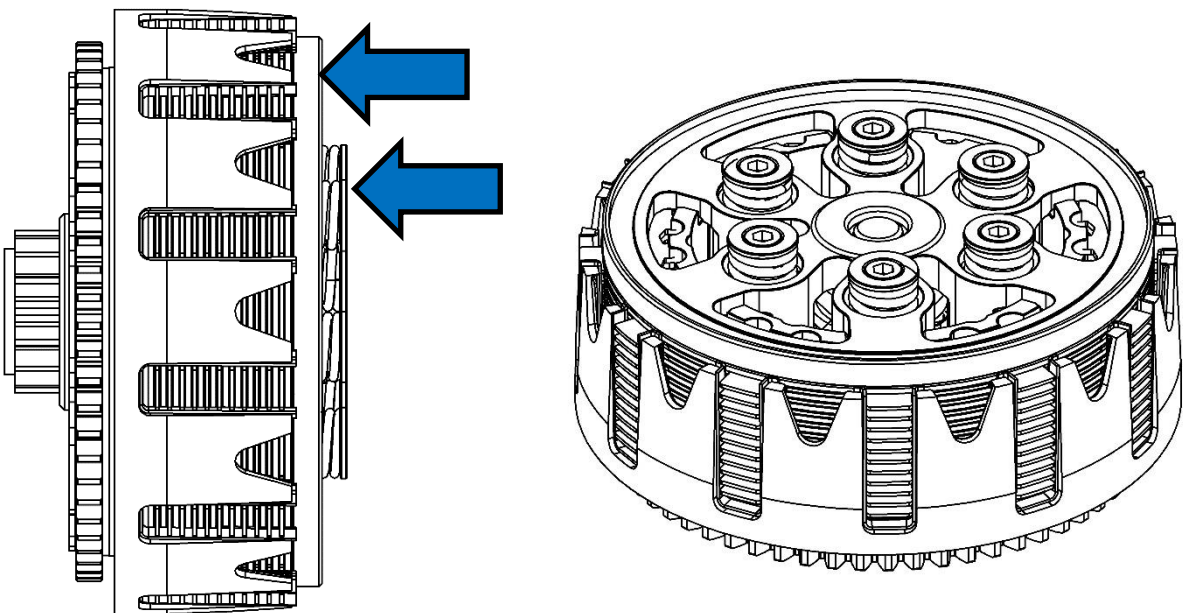

SPRING OPTIONS

Do not use higher force pressure plate springs than those included in the kit. Charts are representative. Differences in clamping force and torque capacity will vary by model. Spring force is directly related to torque capacity. See the descriptions for additional information.

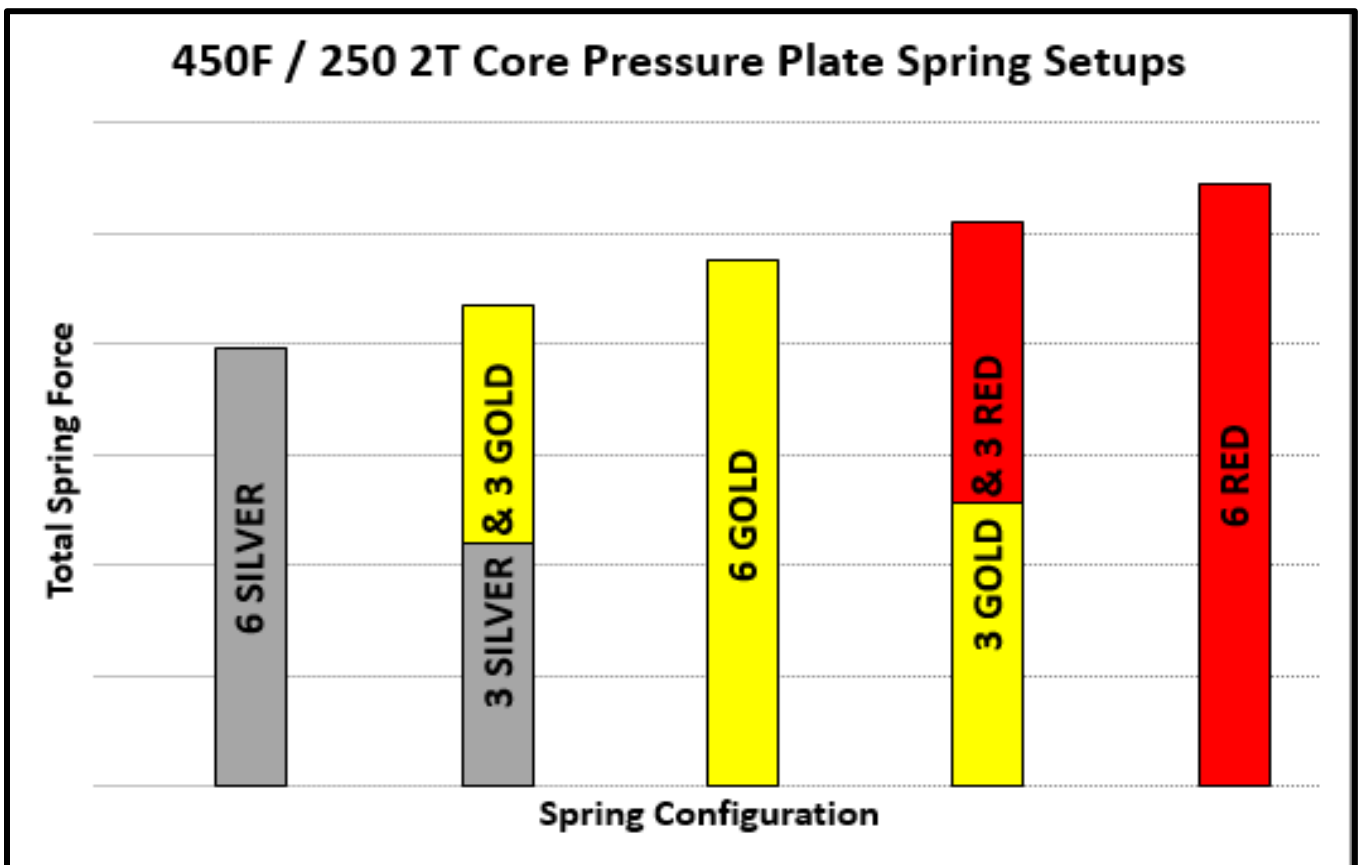
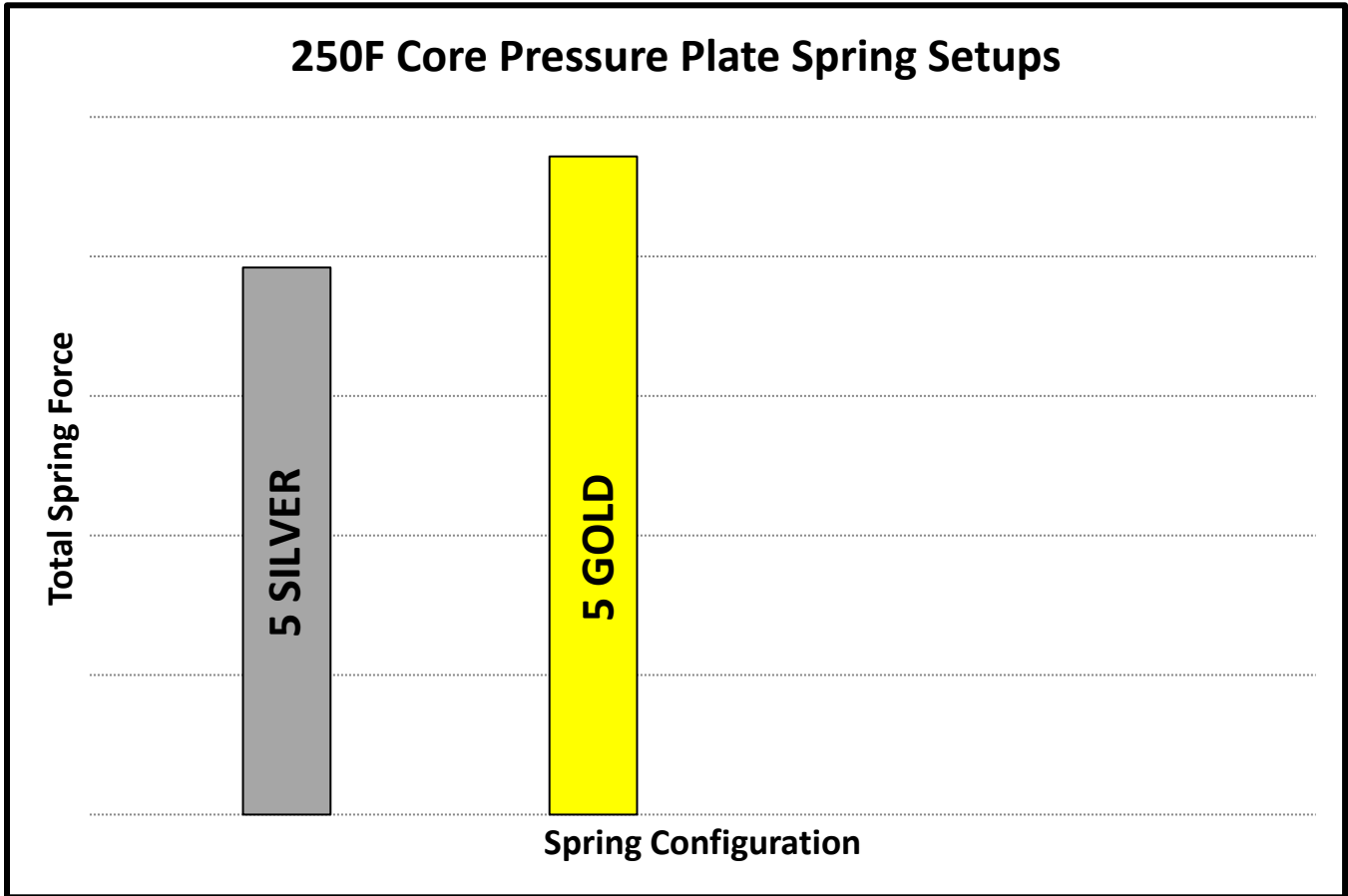

5 spring clutches: There are two spring options.

- Silver springs will give the feel of a smoother clutch with a clutch lever pull about equal to OE.
- Gold springs will yield a more aggressive clutch with clutch pull slightly higher than OE. For best performance and clutch life, gold springs are recommended.

6 spring clutches: There are three configuration options included in your spring kit.

- A lower force spring setting (see chart) will give the feel of a smoother clutch with a clutch lever pull that is much lighter than stock. The higher force spring setting will yield a more aggressive clutch with clutch pull similar to stock.
- Be sure to alternate springs when using 3 & 3 to keep even pressure on the clutch pack.
- For the highest performance and best clutch pack life, the configuration with the highest spring force is recommended.

6. Use a torque wrench and socket to torque the cap screws by lightly tightening the screws in small increments. Torque the cap screws to **9 ft-lb (12 N-m)**.

CLUTCH COVER INSTALLATION

1. Install the clutch cover gasket:
 - a. If your kit came with a Rekluse gasket, install it. Otherwise use the OE gasket
2. Install the Rekluse clutch cover.
3. Reinstall the clutch cover bolts, then lightly tighten the cover bolts in small increments in a star pattern. Torque the cover bolts to OE specifications.

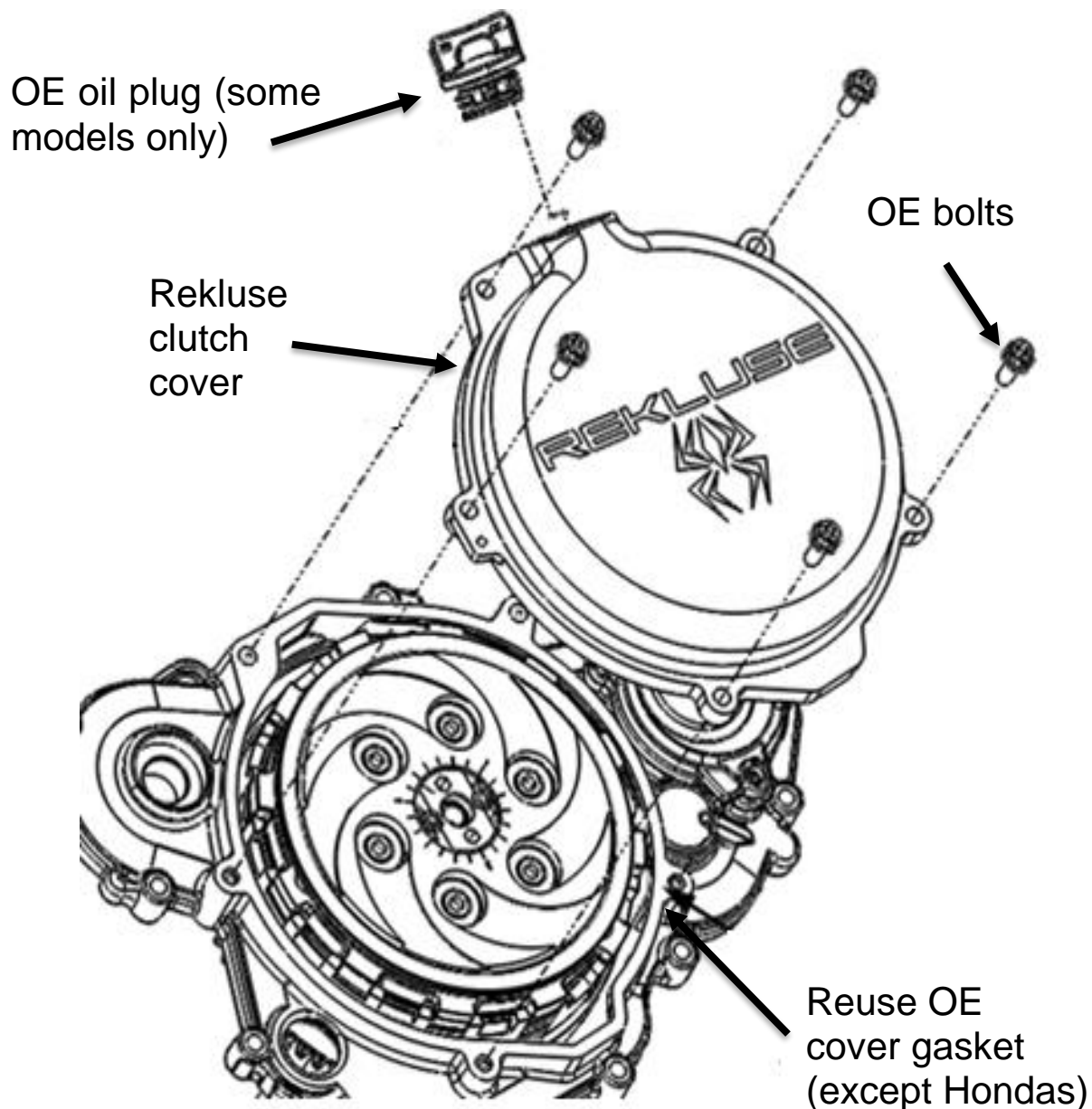

4. If your OE clutch cover has an oil fill plug and/or engine inspection plug, reinstall the plug onto the Rekluse cover.

BREAK-IN

Break-in will occur over the first 1-2 hours of use, depending on the rider. During break-in, more clutch drag may occur than normal.

MAINTENANCE

- Inspect all of your clutch parts at regular maintenance intervals for signs of wear or excessive heat, and replace components as necessary. Clutch wear is very dependent on the rider's use, inspection interval may vary.
- Keep up with regular oil changes and other bike maintenance. Ultimately, better clutch longevity and performance is greatly increased with oil quality and other bike factors that reduce engine heat.
- Replace friction disks regularly for best clutch component life, especially if they appear glazed and/or burnt upon inspection.

NEED ADDITIONAL HELP?

Website

www.rekluse.com/support

Frequently Asked Questions

www.rekluse.com/faq

Support Videos

www.rekluse.com/support/videos

Phone

(208) 426-0659

Technical Support

Contact Technical Support for questions related to product installation, tuning, and performance.

Hours:

Monday thru Friday: 8:00 a.m. - 5:00 p.m.

Mountain Time zone

Email: tech@rekluse.com

Customer Service

Contact Customer Service for additional product information, orders, and returns.

Hours:

Monday thru Friday: 8:00 a.m. - 5:00 p.m.

Mountain Time zone

Email: customerservice@rekluse.com



SETUP SHEET 198-7104140

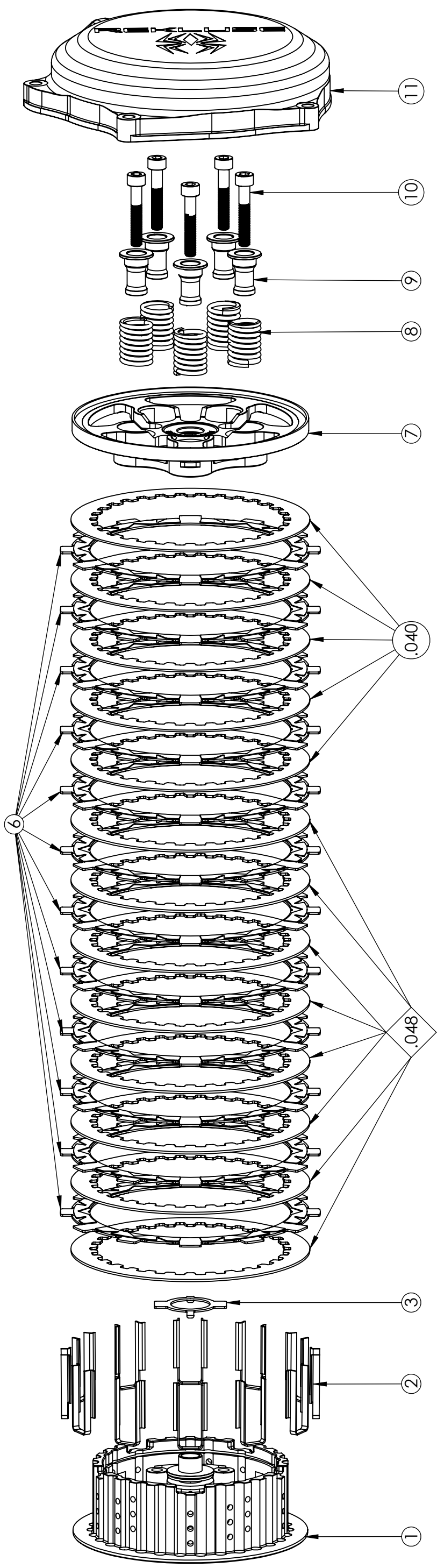

PRESSURE PLATE SPRING TUNING OPTIONS

CLUTCH TORQUE CAPACITY	SPRING CONFIGURATION
LIGHT	5 SILVER
AGGRESSIVE	5 GOLD

NOTE: MORE AGGRESSIVE PRESSURE PLATE SPRINGS WILL INCREASE TORQUE CAPACITY AS WELL AS CLUTCH LEVER STIFFNESS

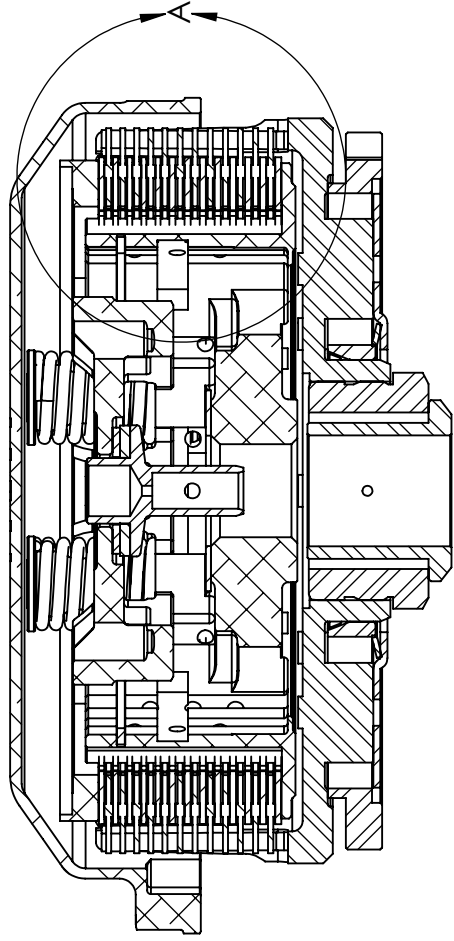
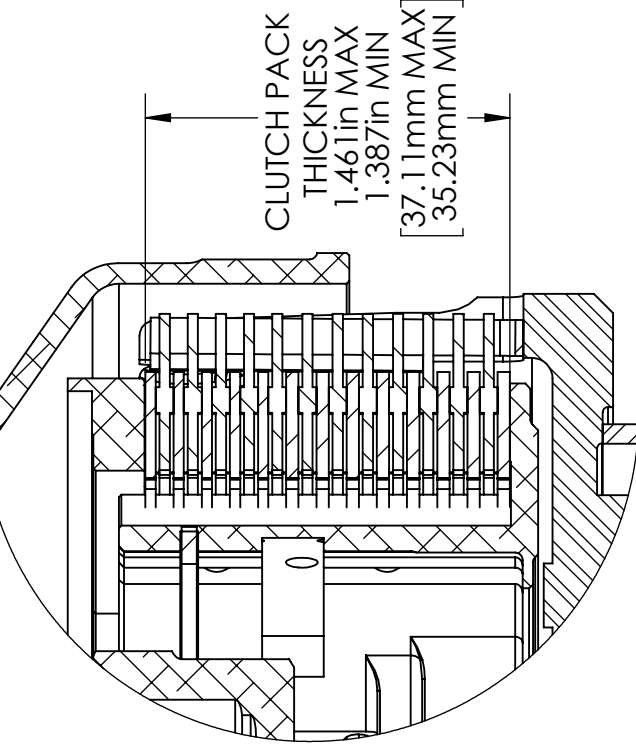

ITEM NO.	DESCRIPTION	QTY.
1	KX250F CENTER HUB	1
2	BASKET SLEEVES	12
3	LOCK WASHER	1
.048	DRIVE PLATE 0.048IN (1.2mm)	8
.040	DRIVE PLATE 0.040IN (1mm)	5
6	TORQDRIVE FRICTION	12
7	REKLUSE PRESSURE PLATE	1
8	REKLUSE PRESSURE PLATE SPRINGS	5
9	Screw Sleeve	5
10	PRESSURE PLATE SCREWS	5
11	CLUTCH COVER	1