

# READ ME FIRST

Doc ID: 193-708A  
Doc Revision: 060614

## BASKET WEAR

The Rekluse TorqDrive clutch employs basket sleeves to protect the basket from wear caused by the friction disks. With the sleeves the basket will no longer notch, which may give the appearance that the basket is not wearing and does not need to be replaced. However, the rubber dampers in the basket assembly will still wear and will eventually break-down. This is a normal wear item that is usually evident by notching of the basket from the OE friction disks. Since the basket sleeves prevent notching, the basket and dampers should be inspected periodically to ensure good function. The basket should also be inspected for any fatigue cracking at the tang bases as worn dampers can increase the likelihood of cracks.

To inspect the dampers, rotate the ring gear and dampers back and forth in opposite directions. This is done best with the basket out of the engine. After removing the basket from the engine, hold the ring gear in one hand and the basket in the other and twist in opposite directions. If any rotational play can be felt between the basket and the ring gear, the dampers are worn and either the dampers or basket assembly need to be replaced. If worn dampers are not replaced, accelerated wear can occur to the rest of the clutch. The rotational play is sometimes accompanied by an audible “click” sound when rotating back and forth.

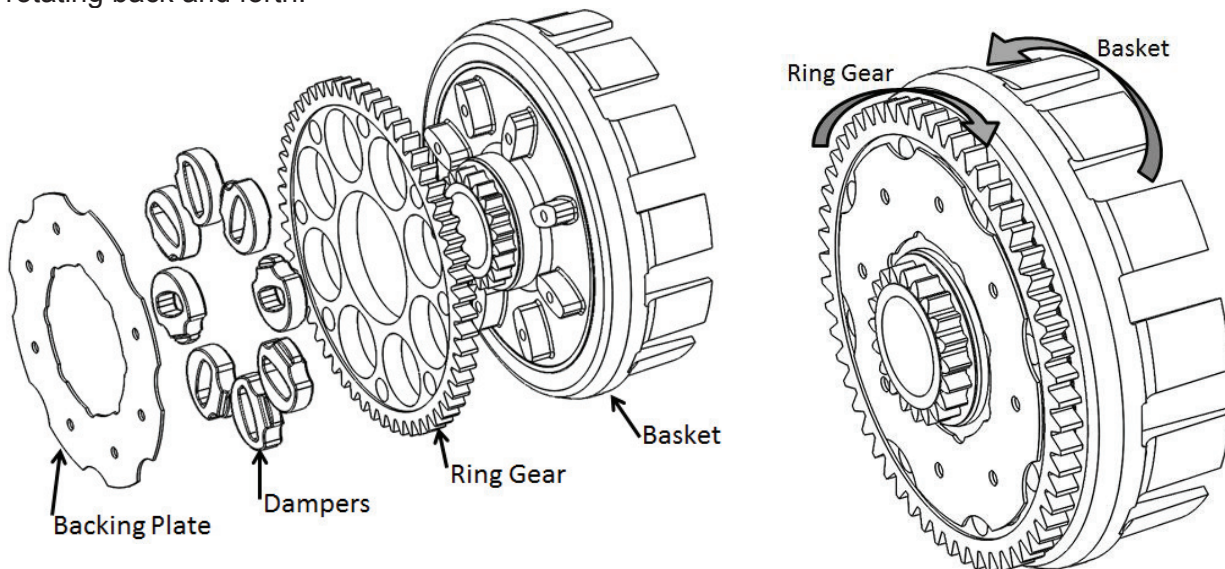

Rotate basket and ring gear in opposite directions  
to check for any rotational play in the dampers

*See the reverse of this page for more information.*

Before installation of the basket sleeves, ensure that the basket tangs are not notched. Notched basket tangs can cause failure of the basket sleeves that can lead to engine damage, bike damage, injury, and/or loss of life. See below image of an example of a notched basket that needs to be replaced.

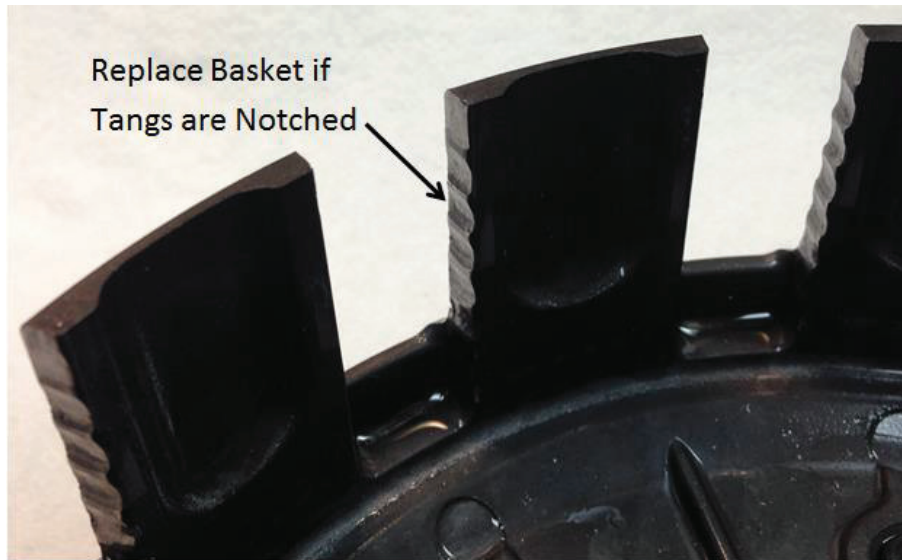

## PRESSURE PLATE SPRINGS

The Rekluse TorqDrive clutch comes with two sets of pressure plate springs so the rider can choose to have either a lighter lever pull or more torque transfer through the clutch. **DO NOT** use higher force springs than those included in the kit. Clutch and/or engine damage could occur from higher force springs which could result in bike damage, injury and/or death.



# **INSTALLATION & USER'S GUIDE**

CoreManual TorqDrive<sup>®</sup> Kit

Doc ID: 191-7101A  
Revision: 042621

# Table of Contents

|   |    |
|---|----|
| OVERVIEW .....                            | 2  |
| INSTALLATION TIPS .....                   | 2  |
| TOOLS.....                                | 3  |
| INCLUDED PARTS .....                      | 4  |
| DISASSEMBLE CLUTCH.....                   | 5  |
| INSTALL THE HUB .....                     | 8  |
| INSTALL THE CLUTCH PACK .....             | 10 |
| Notes for Clutch Pack Installation: ..... | 10 |
| Pressure Plate Spring Information .....   | 13 |
| FINISH INSTALLATION .....                 | 14 |
| BREAK IN .....                            | 16 |
| MAINTENANCE.....                          | 16 |
| NEED ADDITIONAL HELP?.....                | 17 |

## OVERVIEW

This kit replaces OE (Original Equipment) or “stock” core clutch components including the center clutch hub and pressure plate with high-quality billet components designed for optimal performance specific to your bike.

- All the OE friction disks will be replaced with Rekluse TorqDrive® friction disks.
- All OE steel drive plates will be replaced with Rekluse drive plates.
- Two spring options are included in the kit.

## INSTALLATION TIPS

- Read the separate included Safety Information document before operating the vehicle with the product installed.
- Read this entire document before performing any steps.

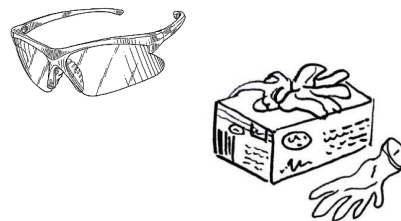

- If you install this product for a customer or another person, instruct them to read the **Safety Information** document and the **Installation and User Guide** before operating the vehicle with the product.
- Protect eyes and skin – wear safety glasses and work gloves.
- Lay the bike on its left side when replacing the clutch. This makes working on the clutch easier and eliminates the need to drain the oil.
- Use an air or electric impact wrench to remove the center clutch nut. If one is not available, you can place the bike in top gear and hold the rear brake while loosening the center clutch nut with a socket and breaker bar.
- Channel-lock pliers work best to bend the tabs of the washer up over the center clutch nut.
- For optimal clutch performance Rekluse recommends using fresh, clean oil that meets JASO-MA oil rating requirements. Rekluse offers Factory Formulated Oil™ developed specifically for Rekluse products. Rekluse Factory Formulated Oil is a perfect complement to any OEM or aftermarket wet clutch. Visit [www.rekluse.com](http://www.rekluse.com) to learn more.
- Use the torque values listed in the instructions. Otherwise, use the torque specifications found in your OE service manual.
- Inspect your OE cable for fraying and replace if needed.

## **TOOLS**

- Metric socket set (at least 8 mm & 10 mm)
- 27 mm, 29 mm, or 30 mm socket (for stock center clutch nut removal)
- Torque wrench (in-lb & ft-lb, or N-m)
- Channel-lock pliers

# INCLUDED PARTS

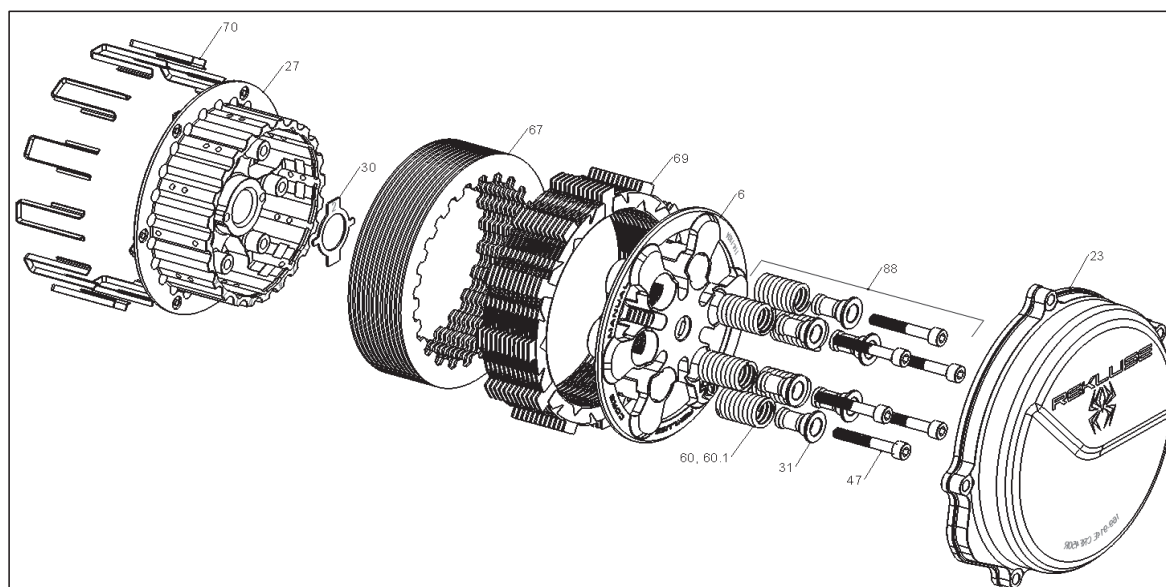

| Item      | Description  | Qty.     |
|-----------|--|----------|
| 70        | Basket sleeves   | 12       |
| 27        | Center clutch hub  | 1        |
| 30        | Lock-tab washer  | 1        |
| 67*       | Thin steel drive plates                                    | 12 or 13 |
| 69*       | TorqDrive® friction disks                                  | 11 or 12 |
| 6         | Pressure plate   | 1        |
| 88        | Core clutch spring assembly                                | 1        |
| 60*       | Pressure plate springs                                     | 5 or 6   |
| 31*       | Screw sleeves  | 5 or 6   |
| 47*       | Socket head cap screws                                     | 5 or 6   |
| 23        | Clutch cover   | 1        |
| Not shown | O-ring cord for use a clutch cover seal (some models only) | 1        |

\*Number depends on bike model

Visit [www.rekluse.com/support](http://www.rekluse.com/support) for a full parts fiche illustration and part numbers.

# **DISASSEMBLE CLUTCH**

1. Lay the bike on its left side. Catch any fuel that might drain in a suitable container.

2. If your clutch cover has an oil fill plug and/or engine inspection plug, loosen them before removing the clutch cover.



3. Using an 8 mm socket, remove the OE clutch cover.

4. Remove the following OE parts from the clutch basket.

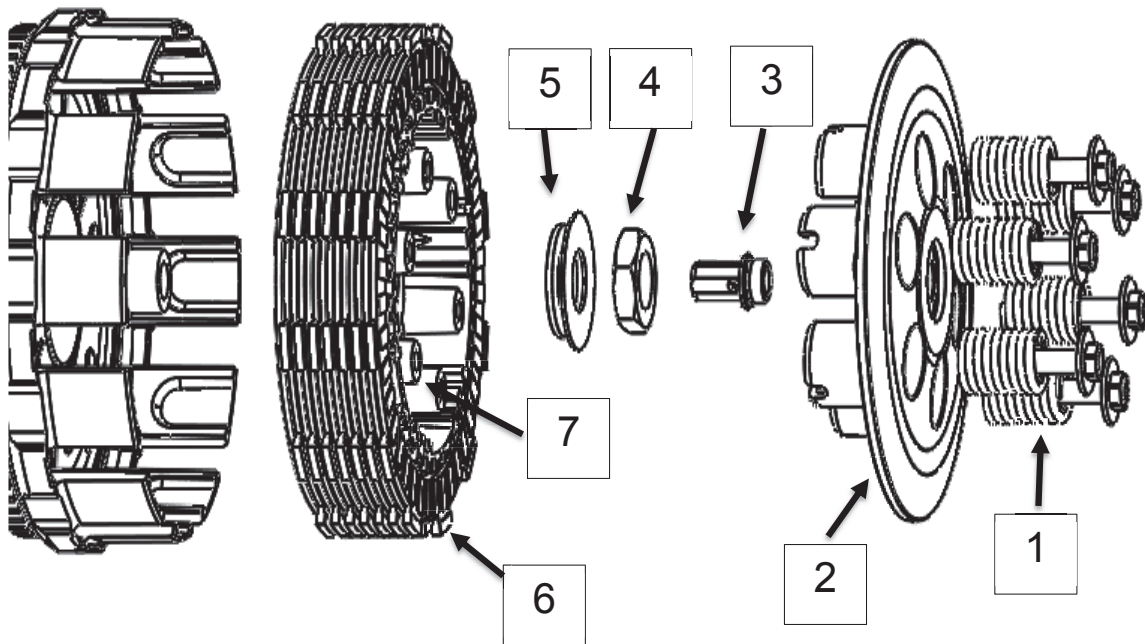

|   |   |
|---|---|
| 1 | Pressure plate springs and bolts – 5 or 6 depending on bike model |
| 2 | Pressure plate  |
| 3 | Throw-out (may include bearing and washer)                        |
| 4 | Center clutch nut   |
| 5 | Lock washer(s) – 1 or 2 depending on bike model                   |
| 6 | Clutch pack   |
| 7 | Center hub  |

5. Inspect the clutch basket for damper/cushion play or notching. Do not install sleeves or use product with a notched basket. Notched basket tang faces or worn dampers can cause the sleeves to break.

**⚠ WARNING**

**Failure to inspect the basket and replace if necessary could result in death, serious injury, and/or property damage.**

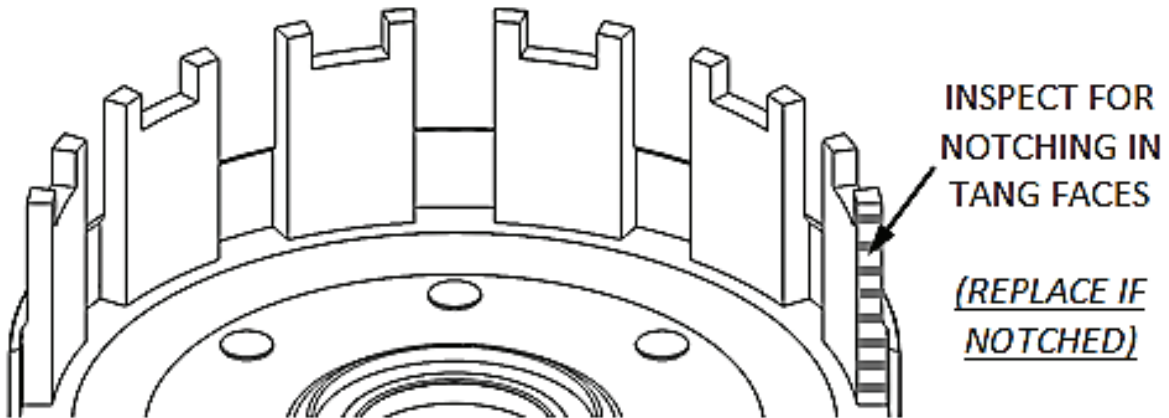

**Note:** *If the basket is notched or worn, Rekluse recommends replacing it with a Rekluse Billet Clutch Basket (available for most models).*





6. Install **ALL** the Rekluse basket sleeves into the basket slots. Make sure the sleeve tabs sit against the inside of the basket, then push the sleeves down until they contact the bottom of the tang slot. See pictures for reference.

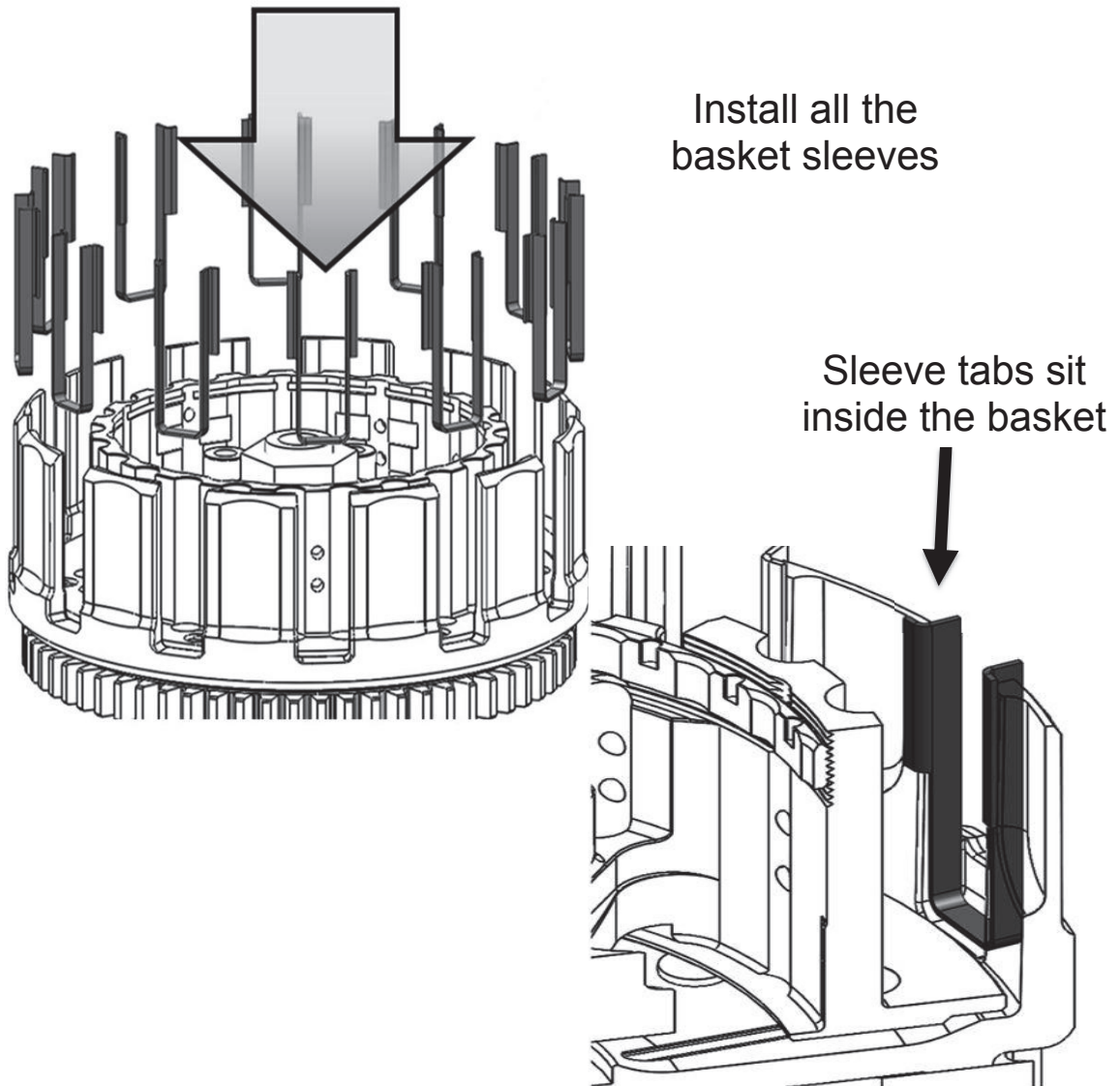

**Note:** *If the basket sleeves fall forward while installing the clutch pack, use a pick to push them back into place. When seated in the basket, the sleeves may stick above or below flush with the top of the basket depending on the bike model. This is normal.*

**Note:** *Rekluse basket sleeves are designed to be installed into an OE or Rekluse clutch basket ONLY. The use of non-Rekluse aftermarket clutch baskets may cause clutch damage or failure.*

# INSTALL THE HUB

1. Check to make sure the OE thrust washer is still on the main shaft.

**Note:** *If the OE thrust washer is missing, it might be stuck to the bottom of the OE center hub. The thrust washer must be installed correctly or clutch performance issues will result.*

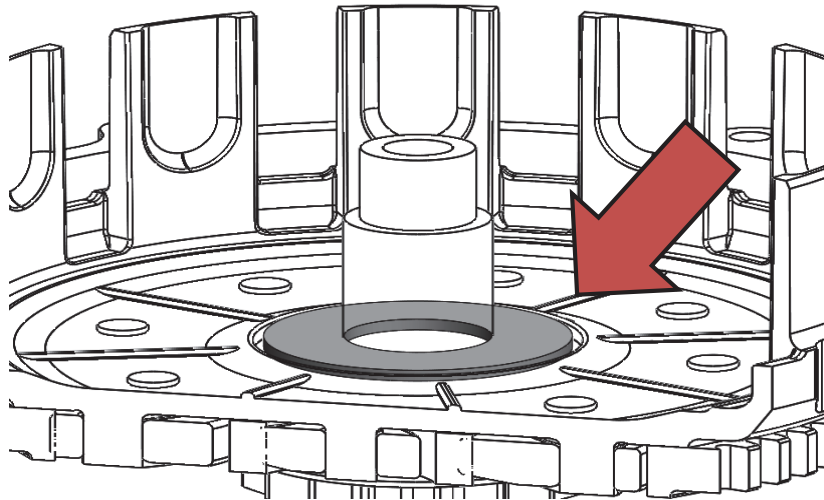

2. Install the new Rekluse center hub.
3. Install the new Rekluse tab washer with the bent tabs facing down, aligning with the holes in the hub. *Only use the supplied lock tab washer under the OE center clutch nut when installing the hub.*



4. Install the OE center clutch nut.

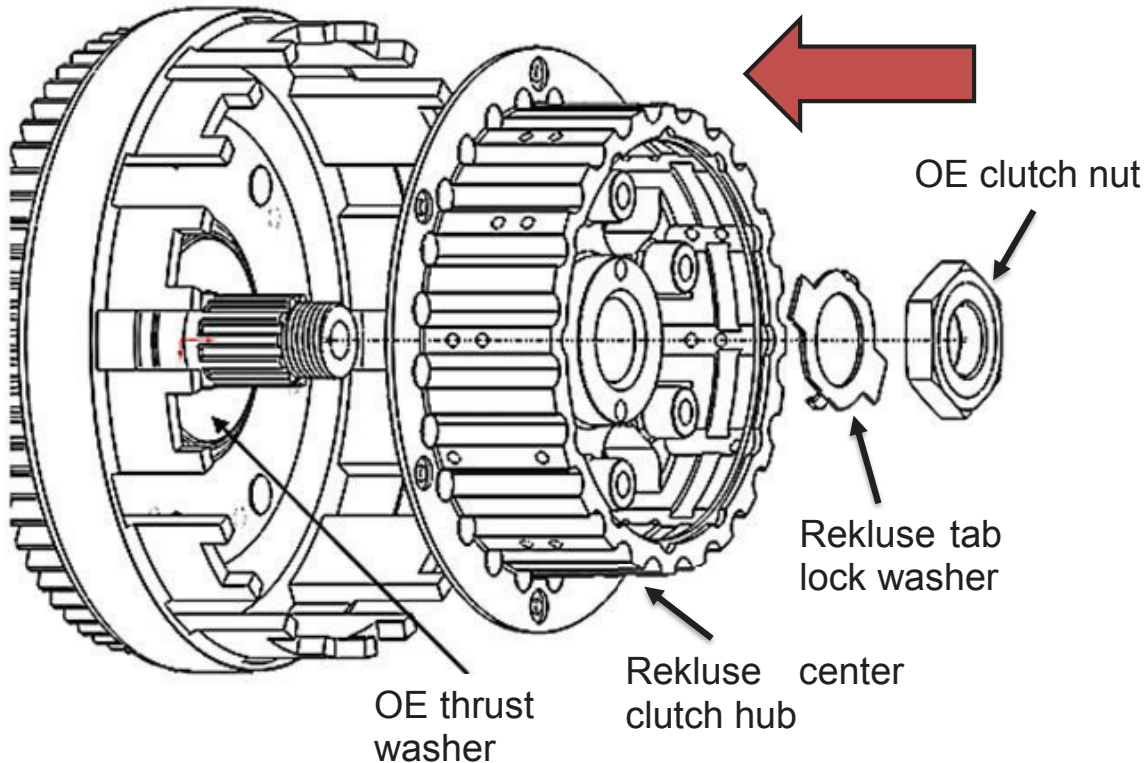

5. Using the socket and torque wrench, torque the center clutch nut to **50 ft-lb (68 N-m)**.

**Note:** *Placing the bike in the highest gear and holding the rear wheel by applying the rear brake keeps the shaft from rotating when tightening the nut.*

6. Using the channel-lock pliers, bend up **both** tabs of the tab washer tightly around the nut. The tabs can be bent on the straight sides or around the corners.

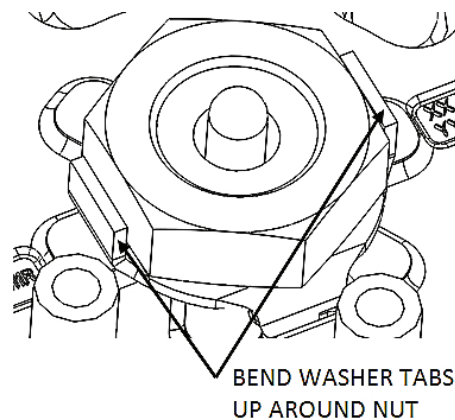

# INSTALL THE CLUTCH PACK

## Notes for Clutch Pack Installation:

- Some friction disks are marked with a small colored dot. This mark is used for processing and can be ignored.
- Some OE basket have “half slots” at the top of the basket tangs. Rekluse products require the entire clutch pack be installed into the MAIN (deeper) basket slots. Installing the pack in the “half slots” will cause performance issues. See the following picture for reference.

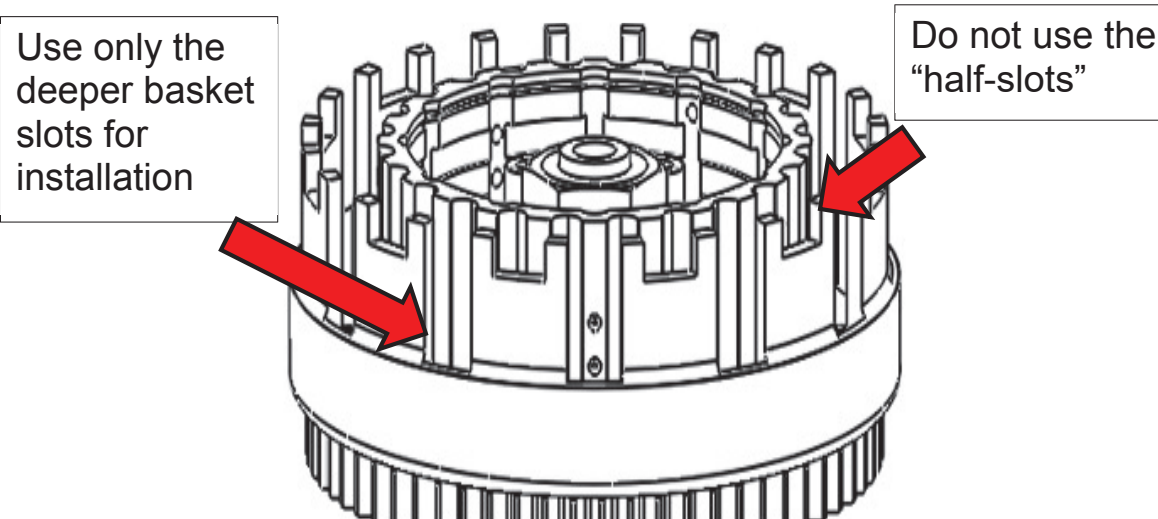

1. Soak the Rekluse friction disks in engine oil for at least 5 minutes. Make sure the friction disks are coated on both sides.

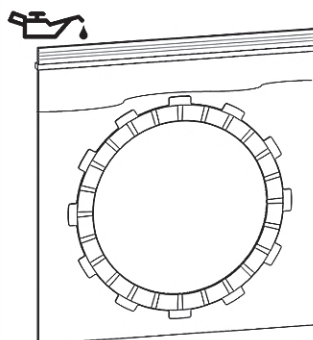

2. Install the Rekluse clutch pack starting with a steel drive plate, then install a friction disk.

**Note:** The clutch pack is installed **without** the OE judder spring and seat.

3. Continue to alternate steel drive plates with friction disks for the entire clutch pack. *The last plate installed is a steel drive plate.*

**Note:** The total number of steel drive plates and frictions depends on the bike model. **See the included Bill of Materials (BOM) for the correct number for your bike model. Some models may also come with a Setup Sheet located at the back of the manual. If included, refer to the Setup Sheet for additional information.**

4. Reinstall the OE throw-out assembly (throw-out, bearing, and washer).

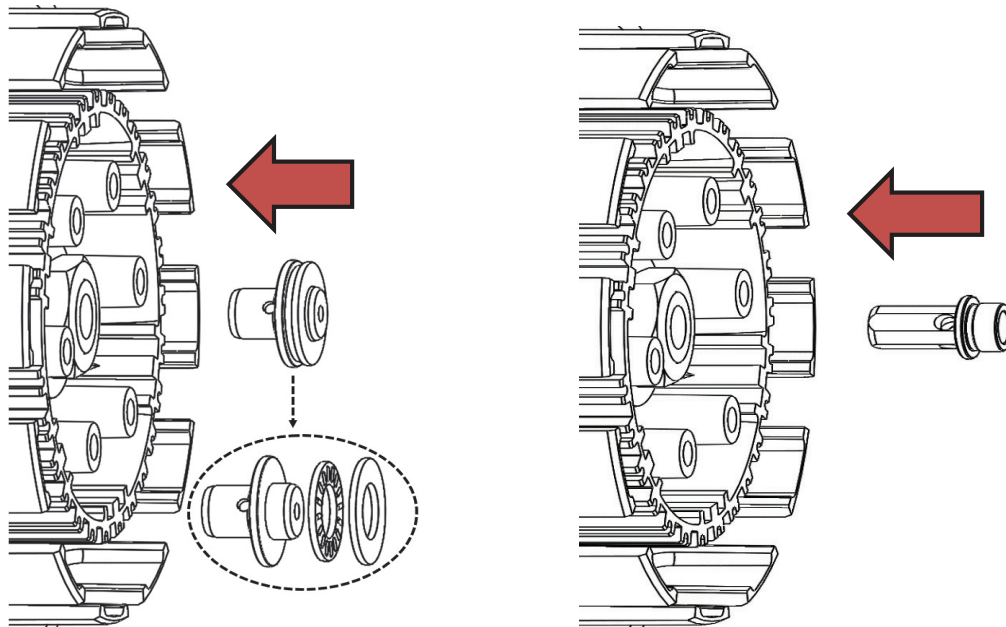

**If the washer is missing:**  
Check to see if it is stuck to the backside of the OE pressure plate

**In some bike models:**  
The throw-out is one piece, with no washer or bearing.

## Clutch pack cross-section

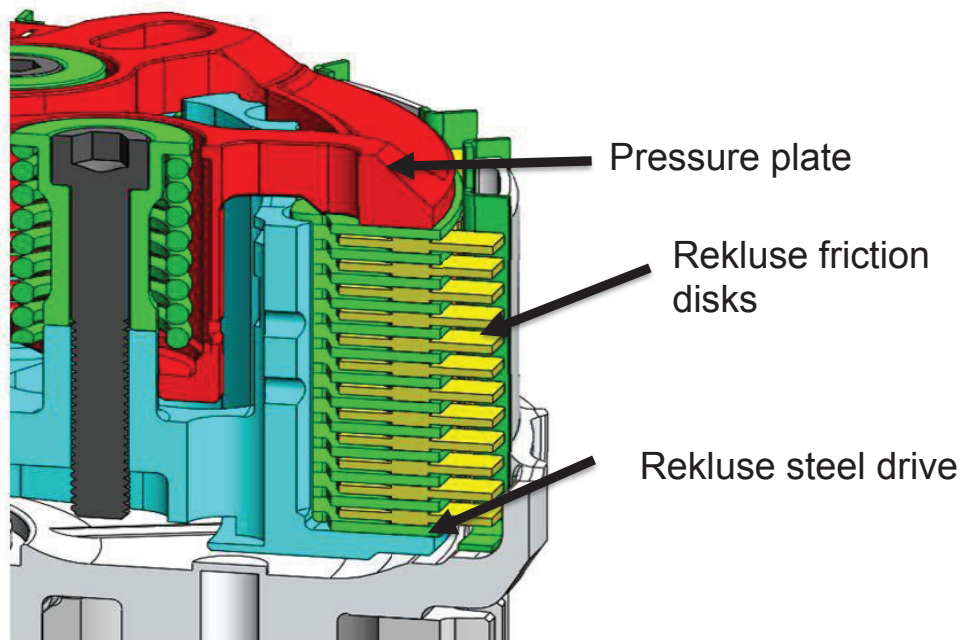

5. Install the Rekluse pressure plate.
6. Install the pressure plate springs, followed by the screw sleeves and socket head cap screws (5 or 6 depending on the bike). *If using two different spring colors, be sure to alternate the springs by color in every other pocket.*

**Note:** *Alternative spring options are available from Rekluse if desired. The springs provided are the recommended setting for optimum balance of performance and lever feel.*

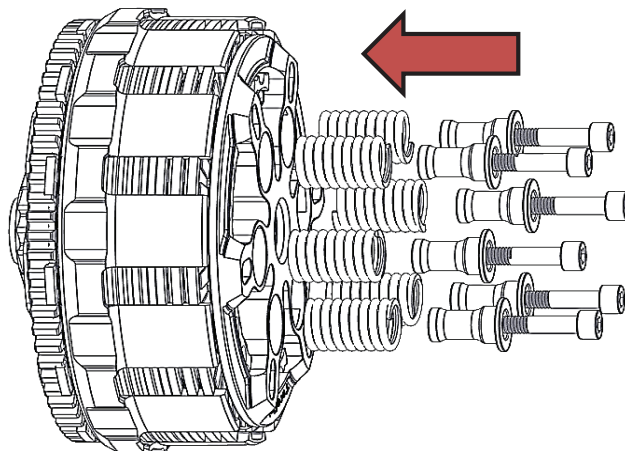

# Pressure Plate Spring Information

Do not use higher force pressure plate springs than those included in the kit. Charts are representative. Differences in clamping force and torque capacity will vary by model. Spring force is directly related to torque capacity. See the descriptions for additional information.

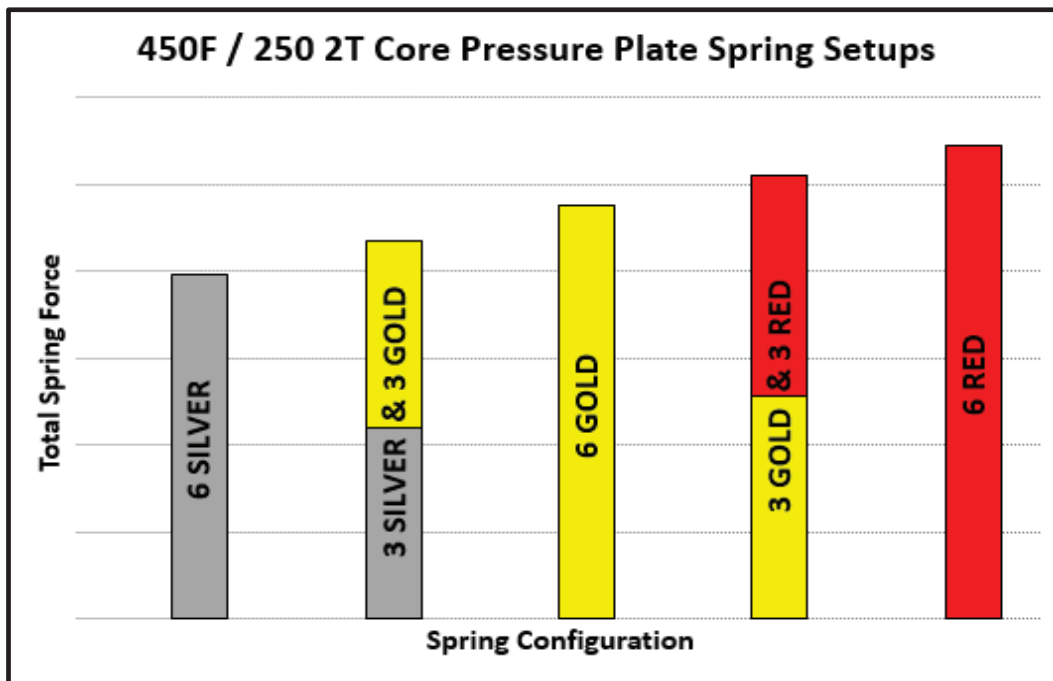
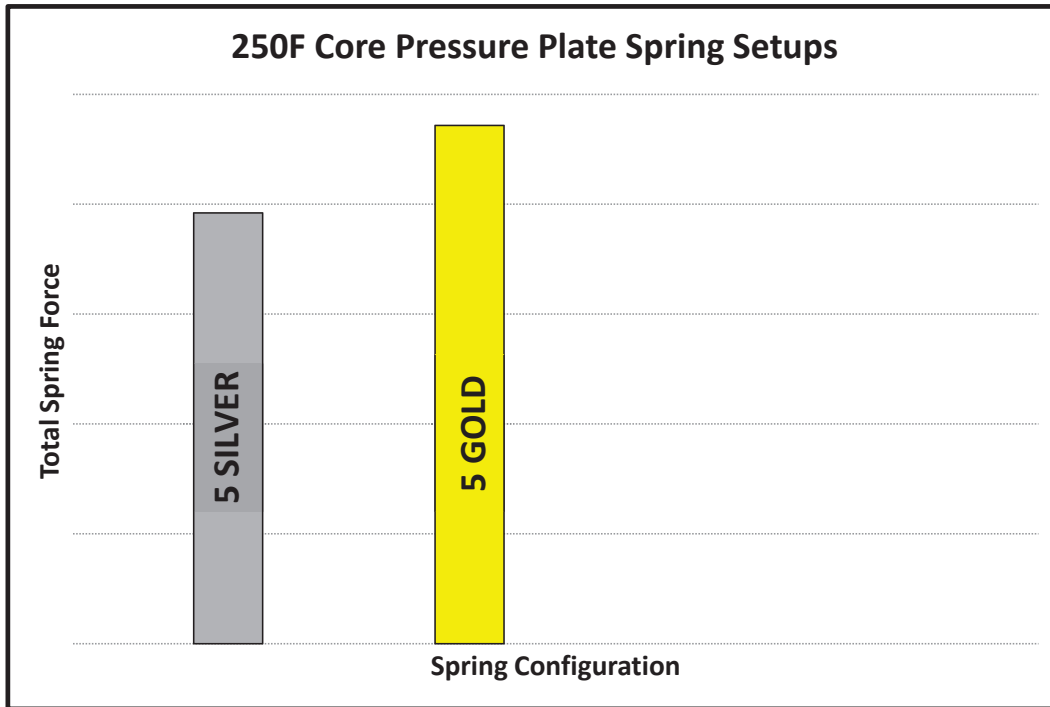

**5 spring clutches:** There are two spring options.

- Silver springs will give the feel of a smoother clutch with a clutch lever pull about equal to OE.
- Gold springs will yield a more aggressive clutch with clutch pull slightly higher than OE. For best performance and clutch life, gold springs are recommended.

**6 spring clutches:** There are three configuration options included in your spring kit.

- A lower force spring setting (see chart) will give the feel of a smoother clutch with a clutch lever pull that is much lighter than stock. The higher force spring setting will yield a more aggressive clutch with clutch pull similar to stock.
- Be sure to alternate springs when using 3 & 3 to keep even pressure on the clutch pack.
- For the highest performance and best clutch pack life, the configuration with the highest spring force is recommended.

7. Use a torque wrench and socket to torque the cap screws by lightly tightening the screws in small increments. Torque the cap screws to **9 ft-lb (12 N-m)**.

## **FINISH INSTALLATION**

1. Install the clutch cover gasket:

- a. If your kit did not come with a Rekluse O-ring cord, reinstall the OE clutch cover gasket or O-ring.
- b. If your kit came with a Rekluse O-ring cord, install the cord into the Rekluse cover.

### **For all Honda models:**

***A cut-to-fit O-ring cord is supplied with your kit.*** Install the O-ring cord onto the clutch cover. Make sure the ends of the cord meet at the top of the clutch cover to prevent leaks. It can be helpful to use superglue to connect the ends of the cord, once cut to length to fit your cover.



2. Install the Rekluse clutch cover.
3. Reinstall the clutch cover bolts, then lightly tighten the cover bolts in small increments in a star pattern. Torque the cover bolts to OE specifications.

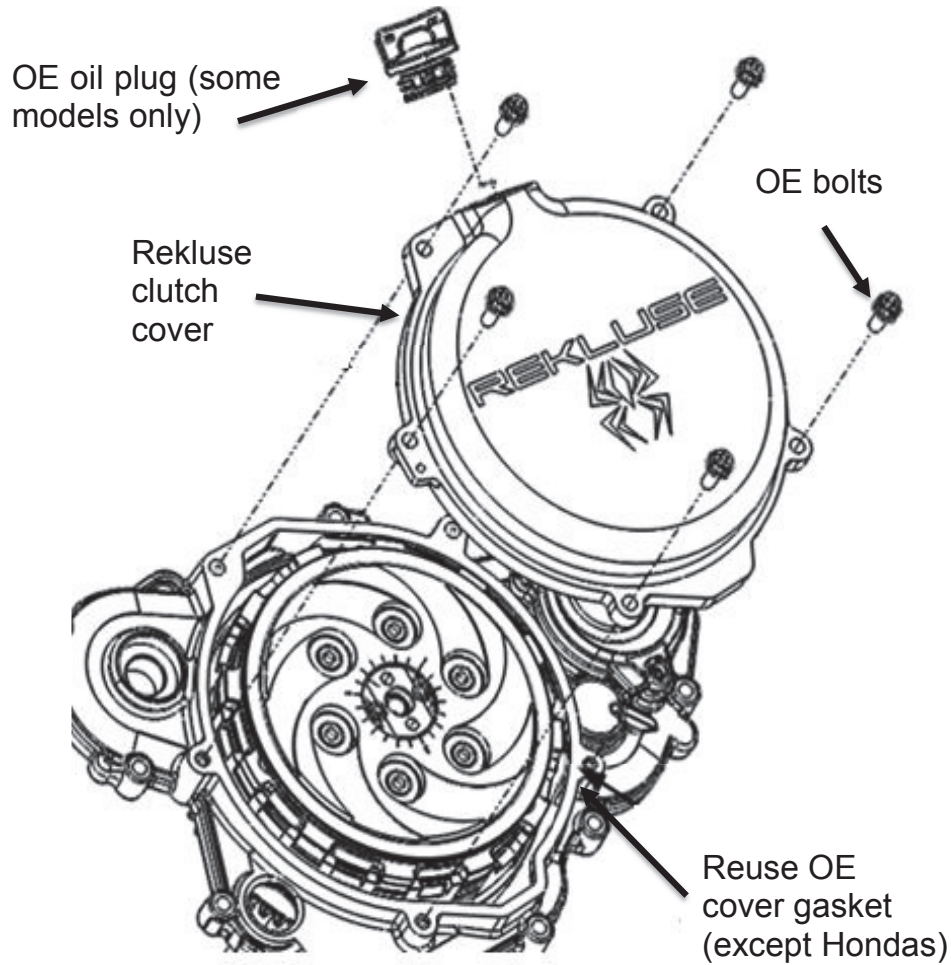

4. If your OE clutch cover has an oil fill plug and/or engine inspection plug, reinstall the plug onto the Rekluse cover.
5. For cable bikes, readjust lever free play to OE specification (10-20 mm). [not necessary for hydraulic bikes].

READJUST LEVER FREEPLAY  
TO OEM SPEC (HONDA SHOWN)

**10–20 mm**  
**(0.4–0.8 in)**



## **BREAK IN**

Break-in will occur over the first 1-2 hours of use, depending on the rider. During break-in more clutch drag may occur than normal.

## **MAINTENANCE**

- Inspect all of your clutch parts at regular maintenance intervals for signs of wear or excessive heat, and replace components as necessary. Clutch wear is very dependent on the riders use, inspection interval may vary.
- Keep up with regular oil changes and other bike maintenance. Ultimately, better clutch longevity and performance is greatly increased with oil quality and other bike factors that reduce engine heat.
- Replace friction disks regularly for best clutch component life, especially if they appear glazed and/or burnt upon inspection.

# **NEED ADDITIONAL HELP?**

## **Website**

[www.rekluse.com/support](http://www.rekluse.com/support)

## **Frequently Asked Questions**

[www.rekluse.com/faq](http://www.rekluse.com/faq)

## **Support Videos**

[www.rekluse.com/support/videos](http://www.rekluse.com/support/videos)

## **Phone**

(208) 426-0659

## **Technical Support**

Contact Technical Support for questions related to product installation, tuning, and performance.

Hours:

Monday thru Friday: 8:00 a.m. - 5:00 p.m.

Mountain Time zone

Email: [tech@rekluse.com](mailto:tech@rekluse.com)

## **Customer Service**

Contact Customer Service for additional product information, orders, and returns.

Hours:

Monday thru Friday: 8:00 a.m. - 5:00 p.m.

Mountain Time zone

Email: [customerservice@rekluse.com](mailto:customerservice@rekluse.com)



# SETUP SHEET 198-7101001

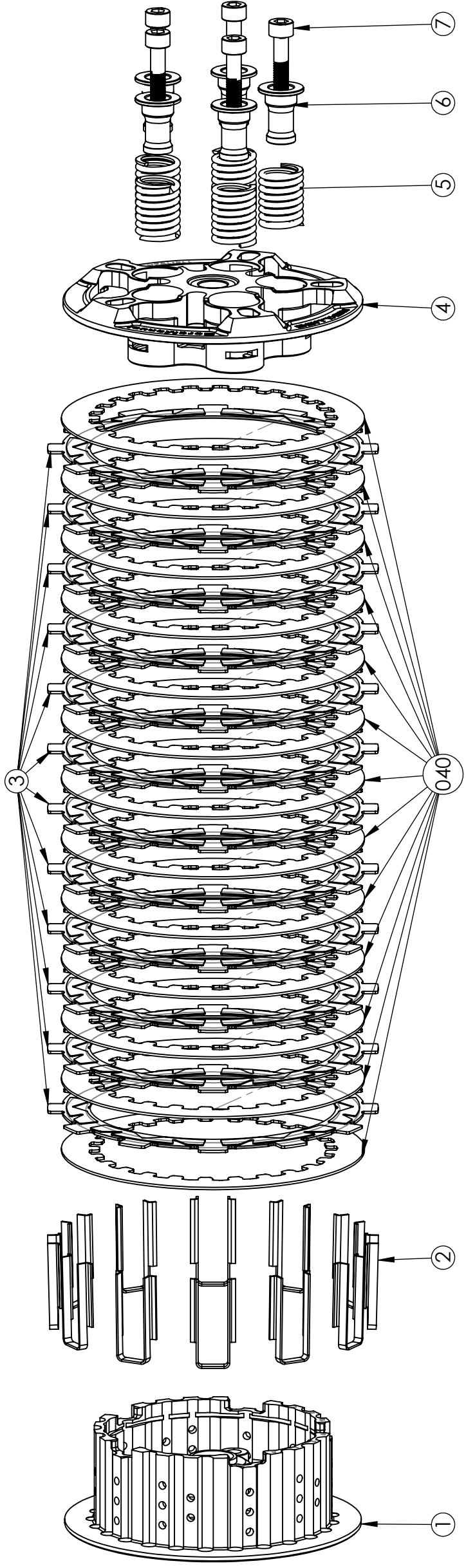

## SERVICE LIMITS

| COMPONENT          | STANDARD                   | SERVICE LIMIT    |
|--------------------|----------------------------|------------------|
| TORQDRIVE FRICTION | .068-.072in<br>1.73-1.83mm | .065in<br>1.65mm |

## CLUTCH PACK THICKNESS

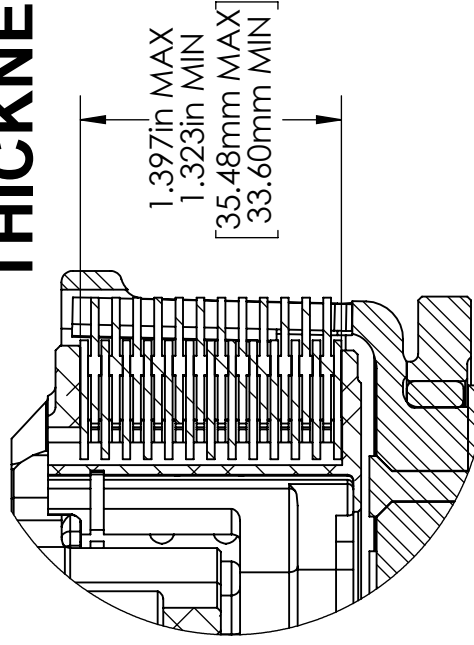

DETAIL A  
SCALE 1 : 1

## COMPONENTS

| ITEM NO. | DESCRIPTION                 | QTY. |
|----------|-----------------------------|------|
| 1        | REKLUSE HUB                 | 1    |
| 2        | BASKET SLEEVE               | 12   |
| 3        | TORQDRIVE FRICTION          | 12   |
| 4        | REKLUSE PRESSURE PLATE      | 1    |
| 5        | PRESSURE PLATE SPRING       | 5    |
| 6        | PRESSURE PLATE SCREW SLEEVE | 5    |
| 7        | PRESSURE PLATE SCREW        | 5    |
| 040      | DRIVE PLATE 0.040" (1mm)    | 13   |