

REKLUSE MOTOR SPORTS

The Rekluse CoreManual Kit for 65cc Bike Models

INSTALLATION & USER'S GUIDE

Doc ID: 191-7087A
Doc Rev: 041019

OVERVIEW

- This kit replaces the OEM core clutch components with high-quality billet components designed for optimal operation specific to your bike model.
- When this installation is performed, the bike's basket assembly will be disassembled and then reassembled using the Rekluse basket. The Rekluse basket converts the clutch from having 12 tabs per friction disk to having 8. This conversion is a necessary upgrade to improve overall clutch performance and the life of the clutch basket, and includes the required friction disks to complement it.

NOTE: Once the basket assembly has been converted to the Rekluse basket, the clutch cannot be returned to a stock configuration without purchasing a new OEM basket assembly. However, it can be converted to an auto-clutch if desired, by purchasing some more components from Rekluse. See the section titled **CONVERSION TO AUTO-CLUTCH** for more information.

INSIDE THIS DOCUMENT

- PREP & DISASSEMBLY
- BASKET ASSEMBLY
- CLUTCH INSTALLATION
- SLAVE CYLINDER INSTALLATION
- OIL TYPES
- MAINTENANCE
- CONVERSION TO AN AUTO-CLUTCH (Rekluse CoreEXP)
- CONVERSION BACK TO STOCK

TOOLS NEEDED

- Metric socket set end-wrench set
- Metric Allen keys
- Dental pick tools
- Torque wrench (in-lb & ft-lb, or N-m)
- Electric drill or drill press
- Motorcycle transmission oil
- Hammer and center-punch set

INSTALLATION TIPS

- Watch the installation video by following this QR code or visiting rekluse.com/support/videos.
- Read this entire document before performing any steps, so you will know what to expect.
- Be sure to use proper eye protection, and wear rubber gloves when handling oils and other fluids.
- Laying the bike on its left side makes clutch work easier and eliminates the need to drain the oil.
- An air or electric impact wrench works well to remove the center hub bolt, or you can place the bike in top gear and hold the rear brake while loosening the center hub bolt with a socket.
- For optimal clutch performance Rekluse recommends using fresh, clean oil that **meets JASO-MA** oil rating requirements. Rekluse offers Factory Formulated Oil™ developed specifically for Rekluse products. Rekluse Factory Formulated Oil is a perfect complement to any OEM or aftermarket wet clutch. Visit www.rekluse.com to learn more.



CLUTCH ASSEMBLY OVERVIEW

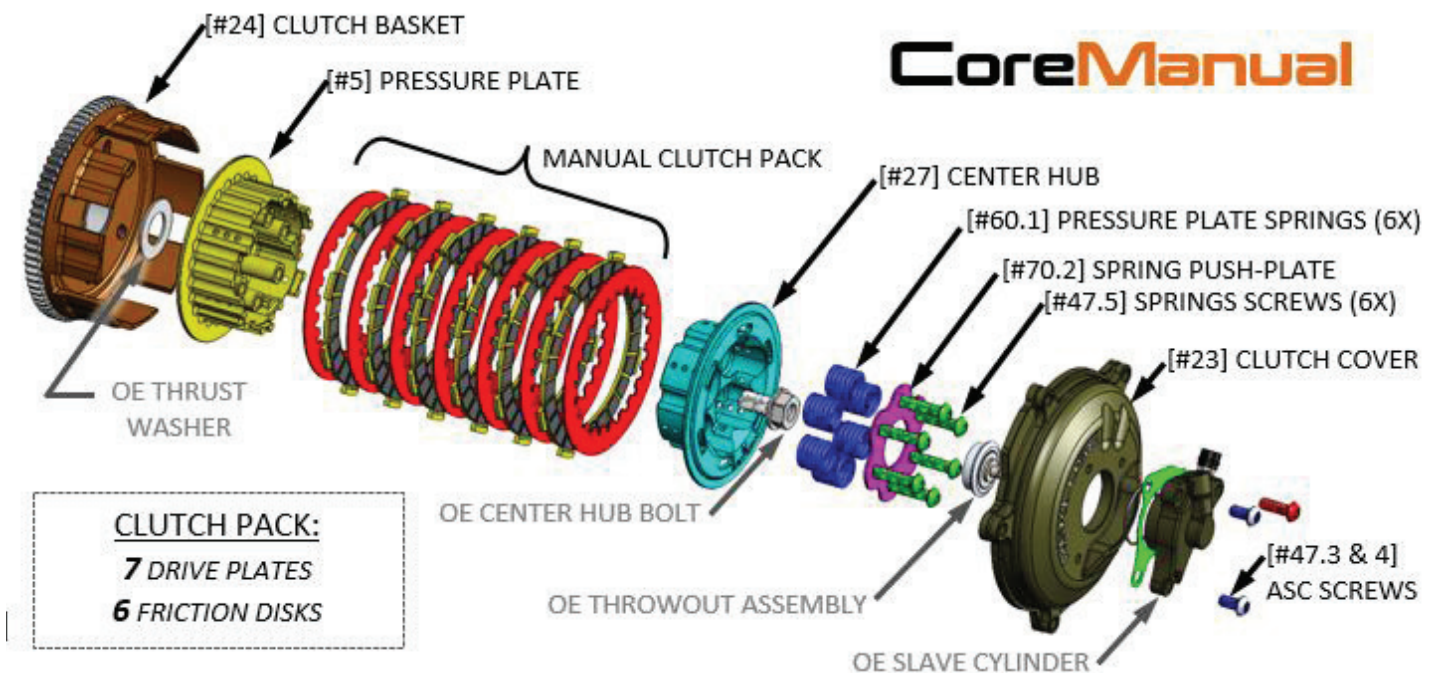

INCLUDED PARTS

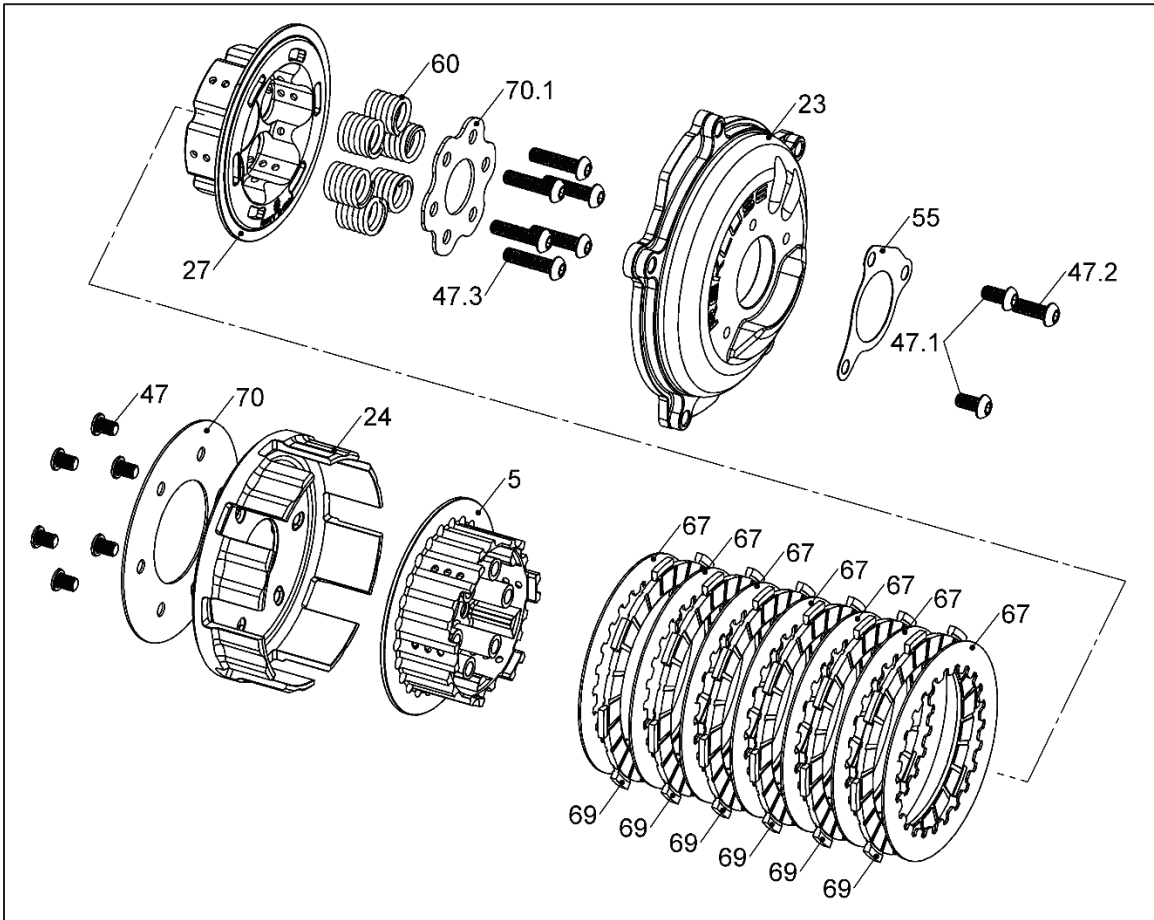

Item #	Item Type	Qty
5	Pressure Plate	1
23	Clutch Cover	1
27	Center Clutch Hub	1
47	Fastener – M6 Low-Head Screw	6
47.1	Fastener – M6 x 12 Button Head Screw	2
47.2	Fastener – M6 x 18 Button Head Screw	1
47.3	Fastener – M6 x 25 Button Head Screw	6
53	O-ring for Slave Cylinder	1
55	Paper Gasket for Slave Cylinder (replacement if OEM gasket is damaged)	1
60	Pressure Plate Spring	6
67	Steel Drive Plate	7
69	Friction Disk	6
70	Basket Backing Plate	1
70.1	Spring Push-Plate	1

The picture above is representative only. See the parts list included with the product or visit Rekluse.com/support for a full parts fiche illustration and part numbers.

PREP & DISASSEMBLY

1. Place the included friction disks [#69] in engine oil to soak for at least 5 minutes.

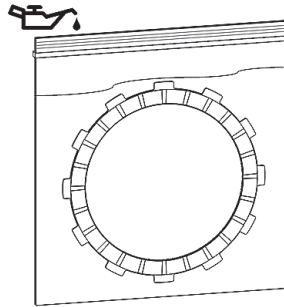

2. Turn off the fuel valve, and lay the bike on its left side. Using a suitable container, catch any fuel that might drain from the carburetor tubes.
3. Remove the bolt from the brake lever ball-joint. *This provides easier access to the clutch cover bolts in the next step.*

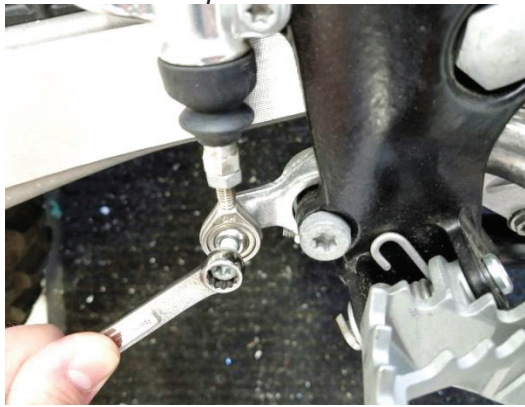

4. Remove the slave cylinder from the clutch cover and move it aside, but do not remove the hydraulic line from it.

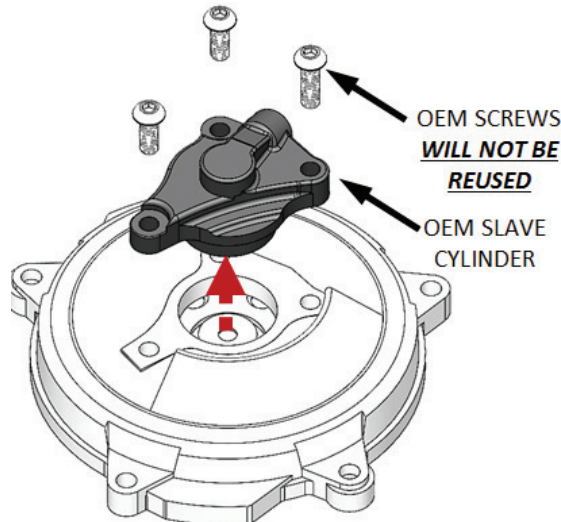

5. Remove the OEM clutch cover from the bike.

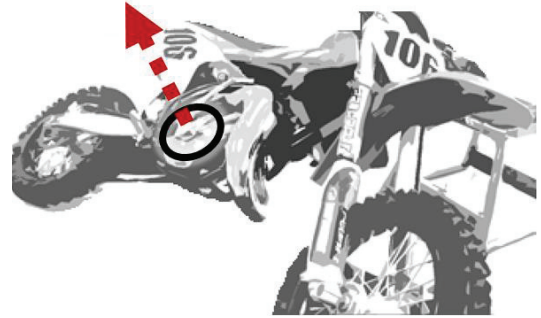

6. Remove the OEM clutch parts named in the following diagram.

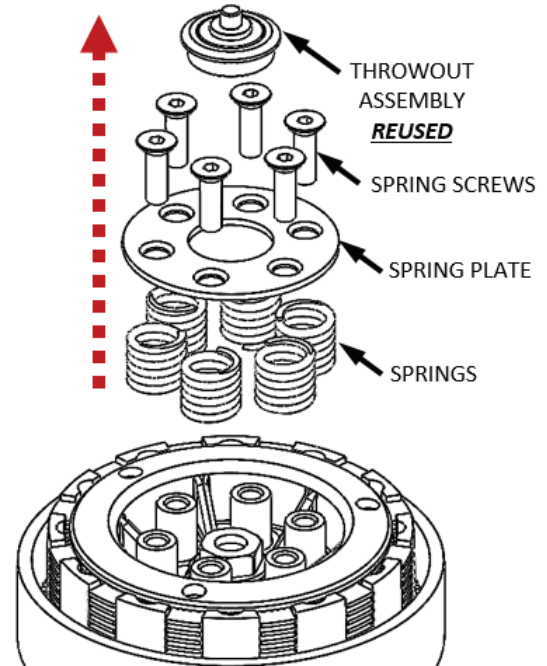

7. Using a 17mm socket, remove the center hub bolt. Then, lift the core of the clutch out by gripping the spring posts and pulling upward.

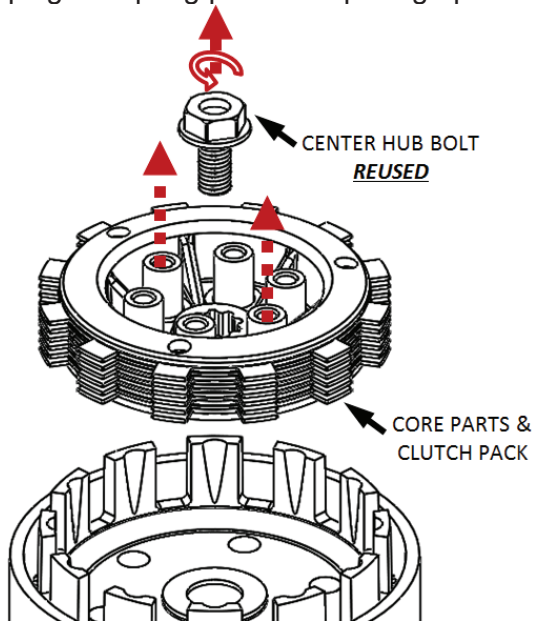

8. Remove the thrust washer followed by the basket assembly. *Ensure that the basket bearings remain on the mainshaft in the engine.*

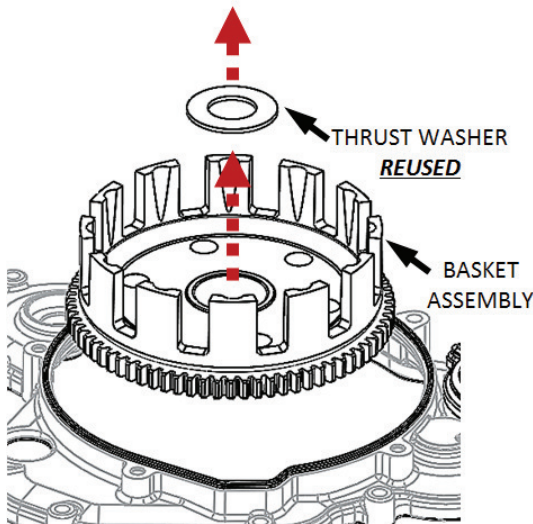

NOTE: If the thrust washer is not in the basket, it is likely stuck to the backside of the hub that was removed in the previous step.

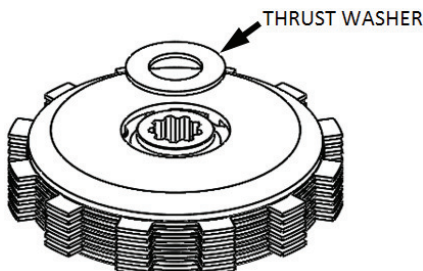

9. Set the OEM basket assembly on a workbench with the ring gear facing upward. Using a center punch and hammer, punch a divot into the center of each of the rivet heads.

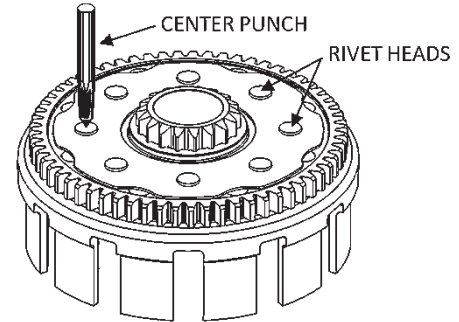

10. Using the drill bit provided, drill the heads off of each rivet, so that the backing plate can be removed from the assembly. *Set your drill to 300-400 RPM and use proper cutting fluid or oil for best results.*

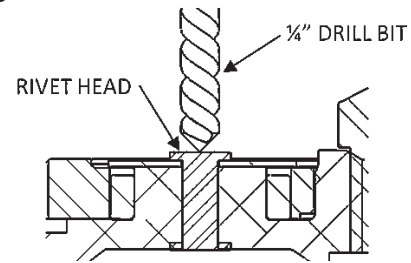

11. Carefully pry off the backing plate and remove the ring gear and rubber dampers from the basket. The OEM basket and backing plate will not be reused.

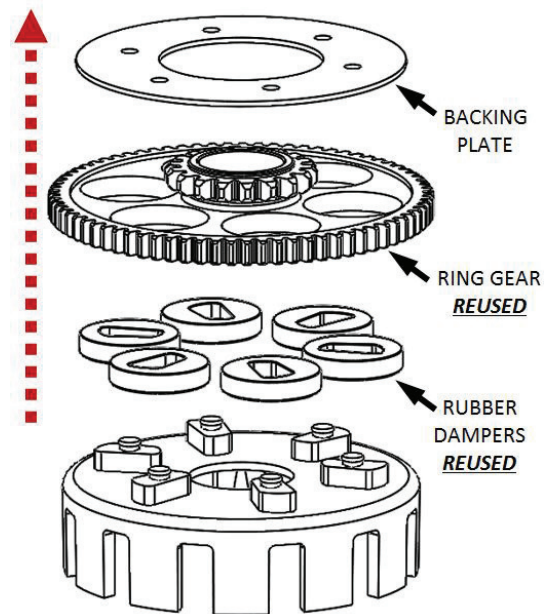

12. Clean the rubber dampers and ring gear of all grit and rivet chips leftover from drilling.

BASKET ASSEMBLY

13. Using the provided Loctite® on the screw threads, recompile the basket assembly using the supplied Rekluse basket, backing plate, and screws.

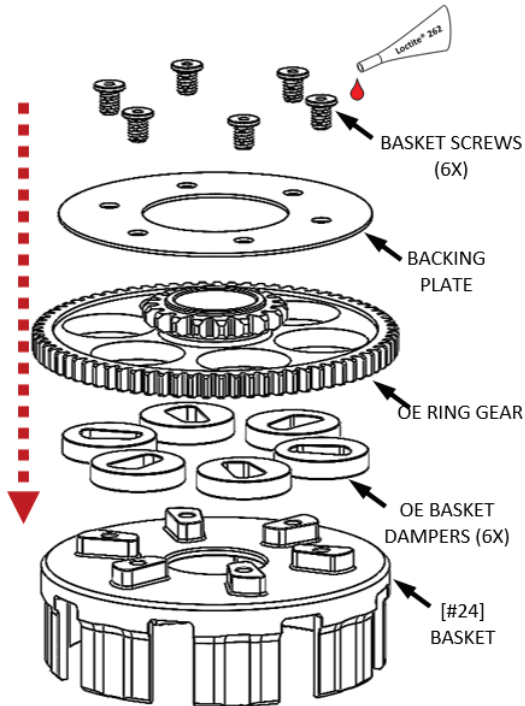

Torque the basket screws evenly to **80 in-lb (9 N-m)** in a crisscross pattern.

14. Using the hammer and center punch, stake the ends of the screws where they protrude through the inside of the clutch basket. **Be sure to stake the screws... DO NOT stake the aluminum basket.**

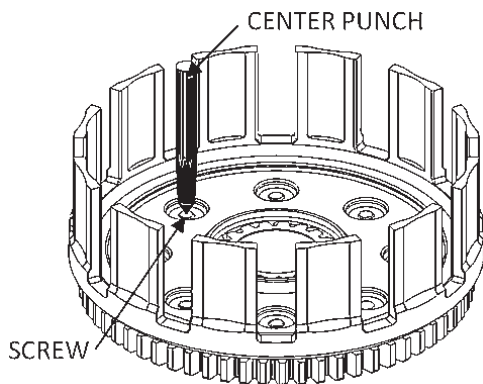

WARNING: It is *critical* that you apply Loctite and stake the ends of the screws or they can back out. Rekluse is not responsible for engine damage that may be caused by screws that back out.

CLUTCH INSTALLATION

Cross-Section Overview: CoreManual

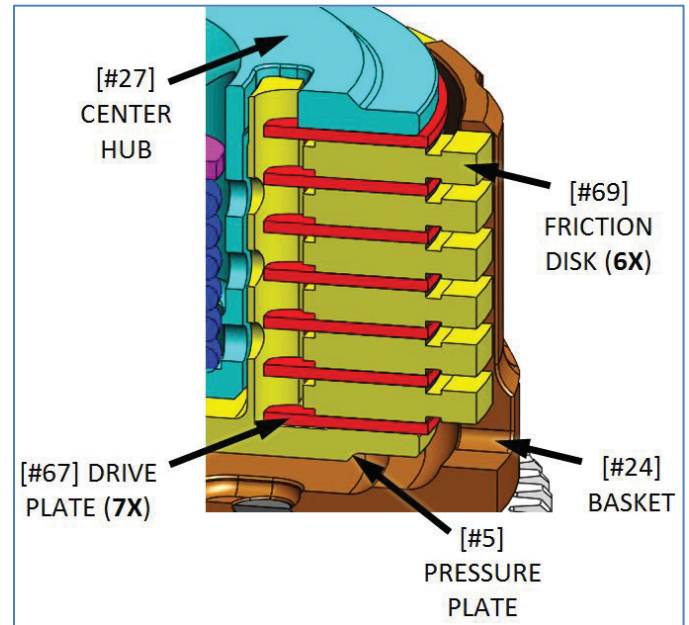

15. Install the newly-compiled basket assembly into the bike over the basket bearings on the mainshaft, followed by the OEM thrust washer.

*To get the ring gear teeth to properly mesh with the crank and kick-starter gears, gently rotate the kick-start lever until the basket drops in and the teeth all mesh. **DO NOT** force the basket in or damage may occur.*

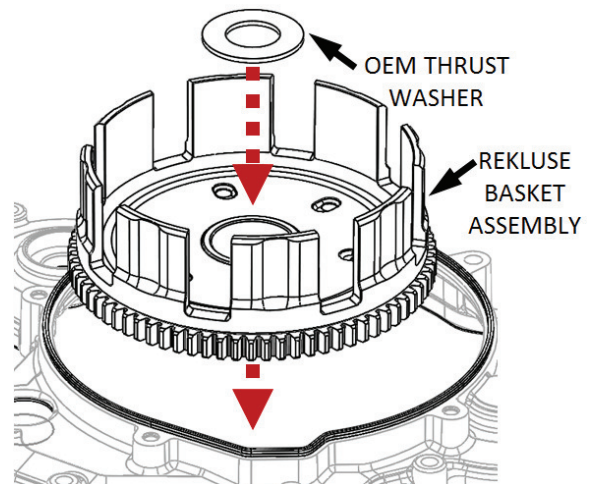

16. Install the Rekluse pressure plate [#5] in the orientation shown below. It will fit loosely in the basket until the clutch plates and hub are installed in the following steps.

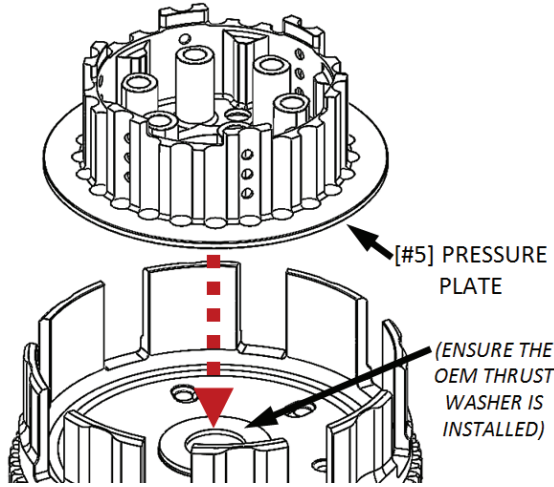

17. Install the Rekluse clutch pack as shown, starting and ending with a steel drive plate [#67]. The EXP disk goes in 2nd, after the first drive plate.

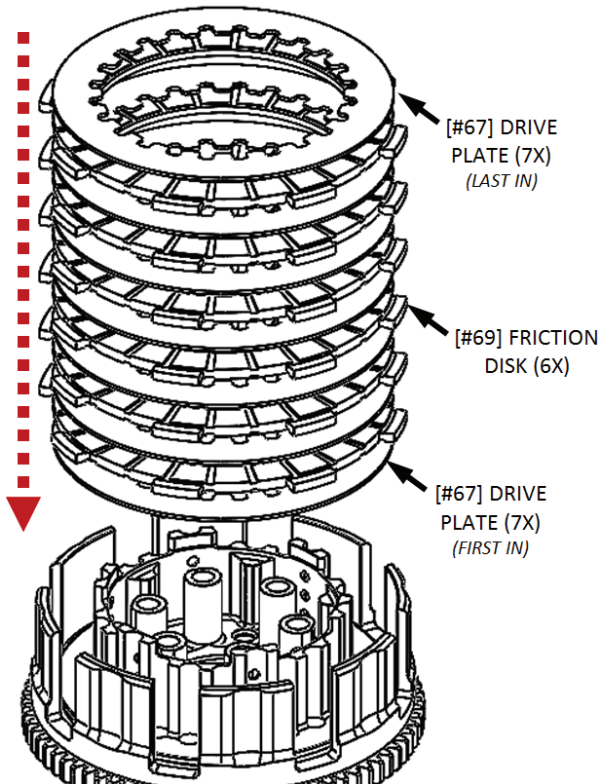

Refer again to the **Cross-Section Overview** at the beginning of this section for clarification.

NOTE: The last drive plate will be indexed to the pressure plate in only the 6 protruding tooth features of the pressure plate. This is normal.

18. Install the Rekluse center clutch hub [#27].

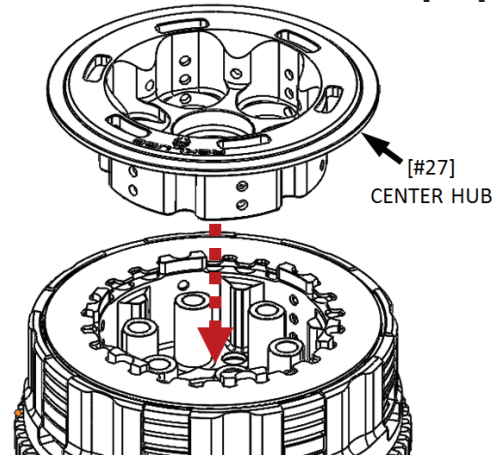

To get the spline in the hub to line up with the mainshaft spline, gently rotate the hub back and forth while installing it until the splines mesh and the hub drops into place. **DO NOT** force the hub into place or damage will occur.

19. Install the provided new pressure plate springs, followed by the Rekluse spring push-plate and button-head screws.

Carefully tighten the screws—each a little at a time in a star pattern to evenly lift the pressure plate—before torquing the screws to **10 N-m (7.5 ft-lb)** in a star pattern.

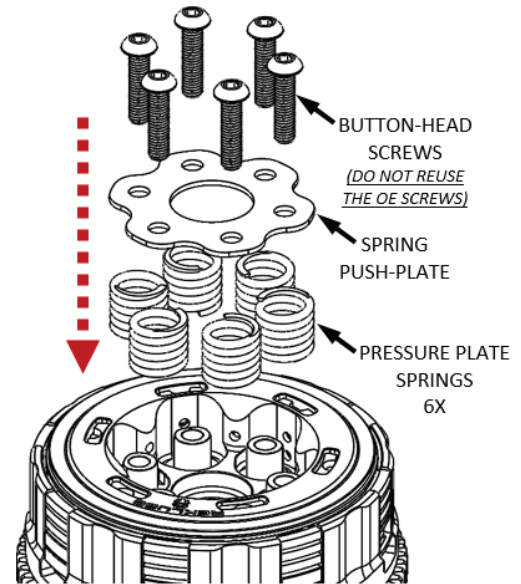

DO NOT reuse the OE screws, as interference with the clutch cover will occur.

NOTE: Shifting the transmission into 5th gear and having a friend hold the rear wheel or rear brake pedal will help to keep the clutch from spinning, and help to torque the screws and center hub bolt.

20. Clean and dry any oil or debris from the threads of the OEM center hub bolt, and apply the supplied Loctite® to the threads on the bolt. Then, install the bolt into the mainshaft, and torque to **60 N-m (45 ft-lb)** using a 17mm socket.

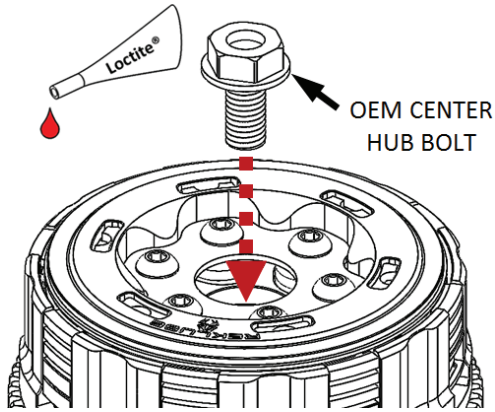

21. Reinstall the OEM throwout assembly piece into the spring push-plate.

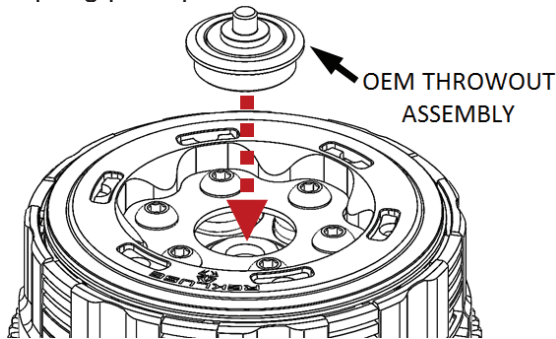

22. Carefully remove the gasket from the OEM clutch cover, and clean it of all dirt and grease using a dry rag or a mild solvent.

Next, install the clean gasket into the groove in the Rekluse clutch cover [#23].

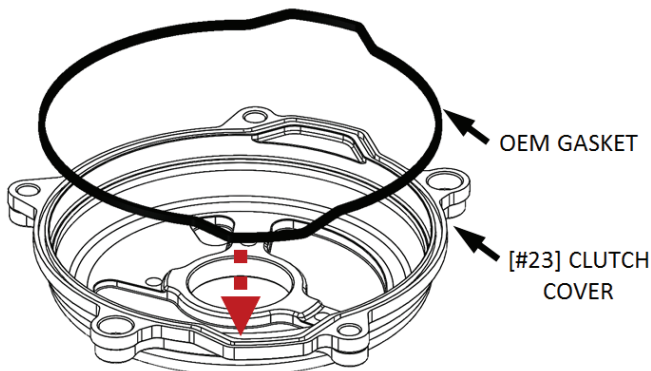

It may be helpful to apply a thin film of clean grease to the gasket to hold it in place in the groove.

23. Install the Rekluse clutch cover [#23] using the five OEM cover bolts. Torque the cover bolts evenly in a star pattern to **10 N-m (7.5 ft-lb)**.

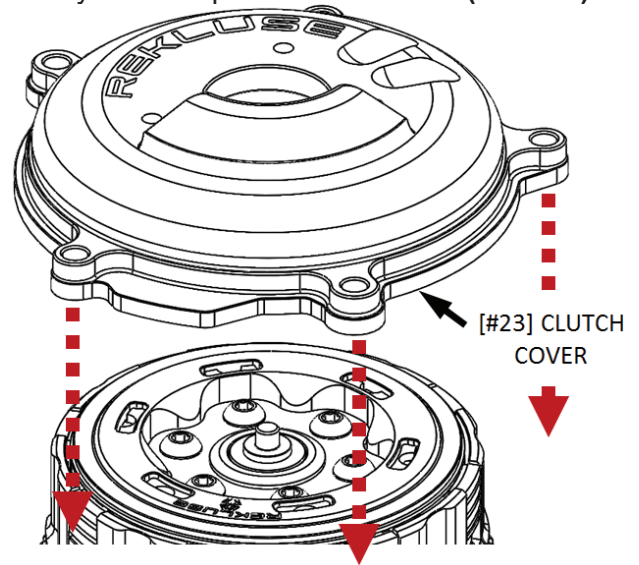

NOTE: The OE clutch cover is *not compatible* with any Rekluse clutch product (CoreEXP or CoreManual) because it does not provide adequate clearance to the moving parts. The Rekluse clutch cover *must* be used with any Rekluse clutch product.

24. Reinstall the bolt into the brake pedal ball-joint. Torque to **10 N-m (7.5 ft-lb)**.

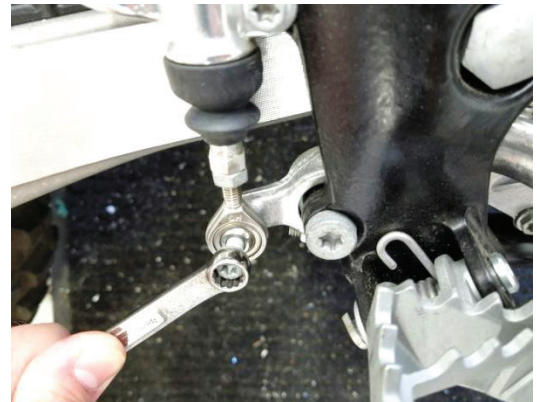

SLAVE CYLINDER INSTALLATION

WARNING

Do not use the OE screws to reinstall the slave cylinder, as clutch damage will occur. To ensure sufficient clearance inside the clutch, use only the Rekluse-provided screws in the orientation shown below.

25. Install the OE slave cylinder onto the clutch cover using the provided paper gasket and screws. Apply Loctite® to the screws and torque them evenly to **10 N-m (7.5 ft-lb)**.

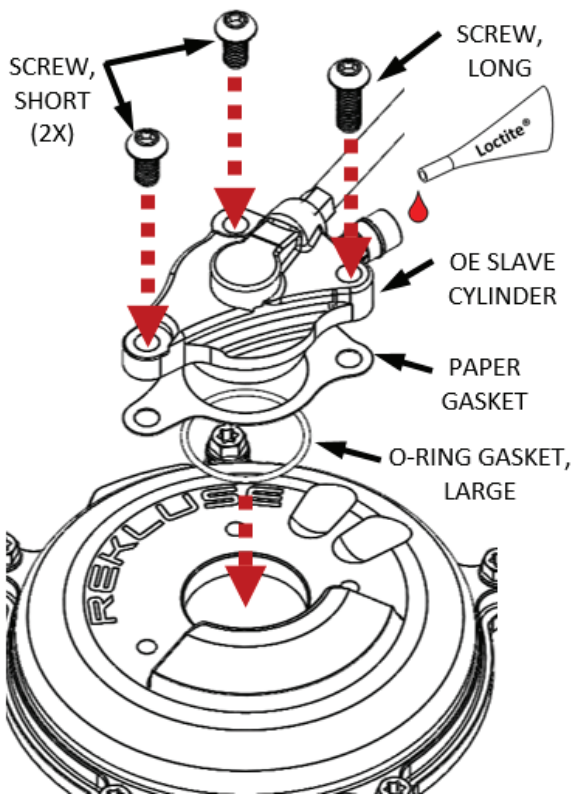

NOTE: The longer screw **MUST** be placed in the hole location where the slave cylinder housing is thickest (rightmost side of the slave cylinder).

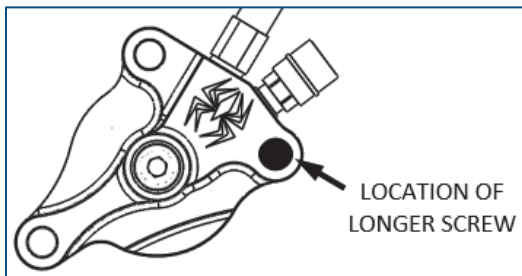

26. Check to ensure that the hydraulic systems functions properly by pumping the clutch lever a few times. The lever should feel exactly like it did with the stock clutch installed.

OIL

For optimal clutch performance Rekluse recommends using fresh, clean oil that **meets JASO-MA** oil rating requirements. Rekluse offers Factory Formulated Oil™ developed specifically for Rekluse products. Rekluse Factory Formulated Oil is a perfect complement to any OEM or aftermarket wet clutch. Visit www.rekluse.com to learn more.

MAINTENANCE

- Keep up with regular oil changes as per the bike manufacturer's recommendations. Clutch function and longevity depends on oil quality.
- Inspect all of your clutch parts **every 20 hours** of operation for signs of wear or excessive heat, and replace components as necessary.
- If you find performance dwindling with use or time it is likely necessary to replace worn clutch disks. Measure your friction disks and replace as necessary.
 - o Friction disk minimum allowable thickness = **0.115" (2.9mm)** Rekluse part #: 469-691
- Excessive heat or clutch slip can cause premature clutch failure. Once extreme temperatures are reached, irreversible damage will occur. Inspect your clutch plates; if the friction disks look burnt or glazed, or the drive plates are blue/black in color or warped, it is best to replace the entire clutch pack.
- Repeat the break-in procedure anytime the friction disks or EXP bases or wedges are replaced. Always soak new friction disks or EXP bases in oil for at least 5 minutes before installing.

CONVERTING TO AN AUTO-CLUTCH (BONUS OPTION)

When the installation of the Rekluse CoreManual clutch is performed, the bike's basket assembly is disassembled and then reassembled using the Rekluse basket instead of the OEM basket. The Rekluse basket converts the clutch from having 12 tabs per friction disk to having 8, which permits the employ of a taller clutch pack than stock. This conversion is a necessary upgrade to improve overall clutch performance and the life of the clutch basket, and includes the required friction disks to complement it.

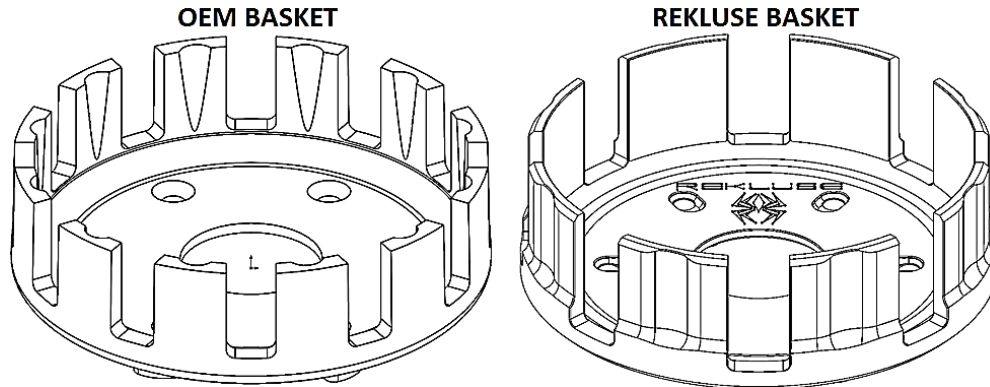

The Rekluse Core components, including the Basket [#24], Center Hub [#27], and Pressure Plate [#5], are compatible with both the CoreManual and CoreEXP (auto) clutches. CoreManual can be converted to a CoreEXP auto-clutch by purchasing the EXP disk and the Adjustable Slave Cylinder assemblies from Rekluse. Follow the directions in the CoreEXP Installation Guide to properly install and check for function.

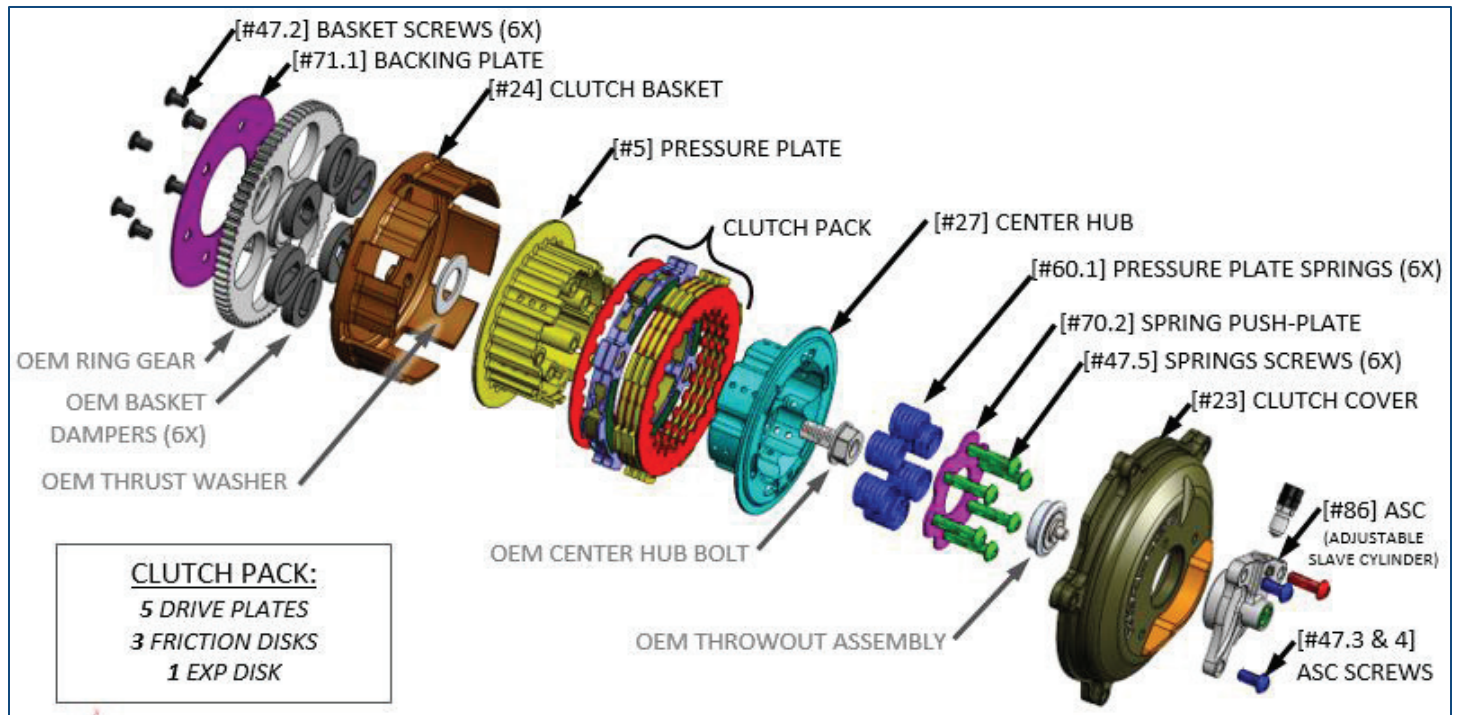

⚠ WARNING

The Rekluse clutch cover [#23] is compatible with CoreEXP & CoreManual clutch products from Rekluse, as well as with the OEM clutch. It is critical that the supplied slave cylinder screws [#47.3 & 47.4] are used if the Rekluse clutch cover [#23] is installed, or internal clutch damage will occur. These screws are shorter than the OEM screws and provide adequate clearance to moving parts. For sufficient clearance, the Rekluse clutch cover [#23] is required when the Rekluse basket [#24] is installed.

Converting to CoreEXP Clutch – Additional Parts Required:

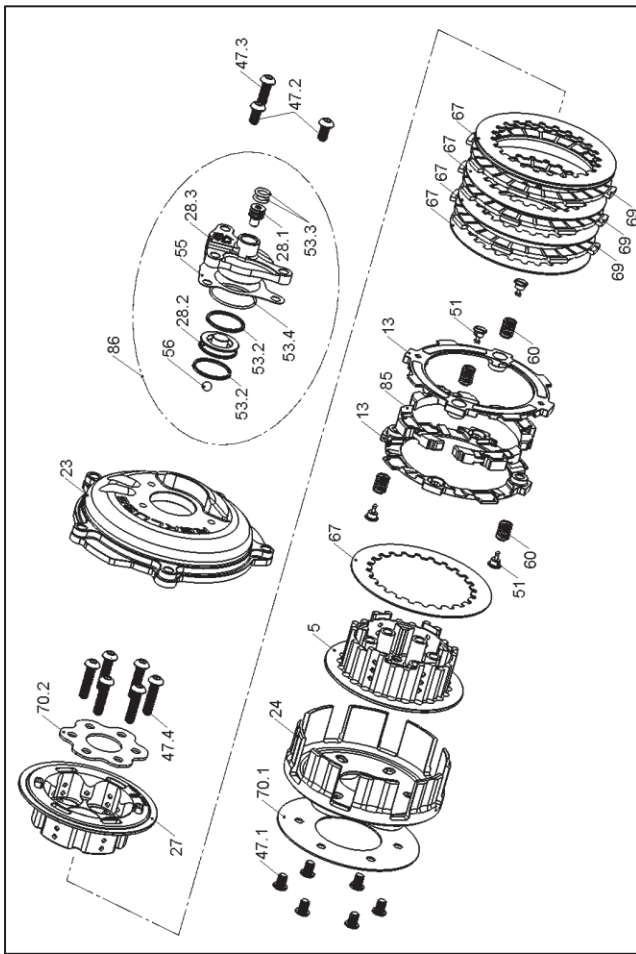

Item #	Item Type	Qty Needed
13	EXP Base	2
51	Fastener - 1/4-Turn Pin	4
60	EXP Adjustment Spring	4
85	Wedge Assembly	4
86	Adjustable Slave Cylinder Assembly	1

Cross-Section Overview: CoreEXP

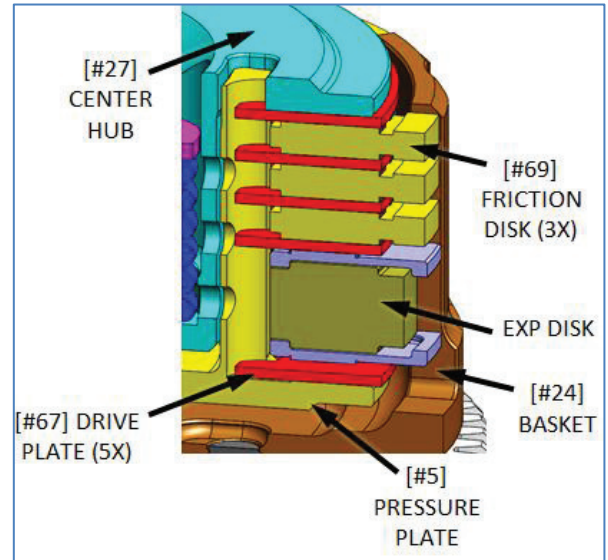

CONVERTING BACK TO STOCK

Once the clutch has been converted to using the Rekluse basket, the clutch **cannot** be returned to a stock configuration without purchasing a new OEM basket assembly.

