

READ ME FIRST

Doc ID: 193-702A
Doc Revision: 022613

The KTM DDS clutch (a.k.a. Belleville spring clutch) employs a 2-piece damped center hub assembly, as shown. Rekluse clutch products employ the same technology and reuse the OEM rubber dampers.

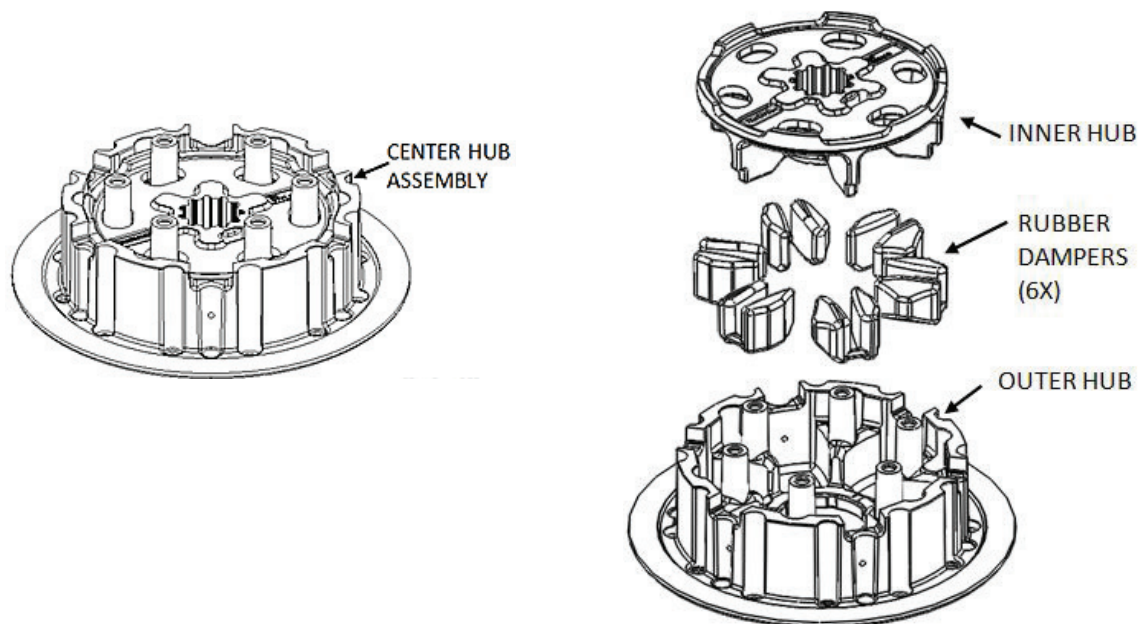

Over time, the rubber dampers will shrink due to heat and use. When this shrinkage occurs, the rotating action between the two hubs becomes loose or sloppy. This can cause hammering between the clutch parts which will reduce the life of the clutch.

KTM recommends inspecting the clutch every 20 bike hours for SX-F models, and every 30 hours for XC, EXC, and XC-W off-road models, and replacing components as necessary. Rekluse has found that these inspection intervals are typically consistent with the expected life of the rubber dampers. For example: the 450 SX-F (including factory edition) engine operates at high temperatures, and its dampers will require servicing at about 20 hour intervals.

Rekluse recommends inspecting the rubber dampers before installing your new Rekluse clutch product. If your bike has reached or exceeded the recommended inspection interval before installation of this product, perform the clutch installation with **new** rubber dampers. After installation of your Rekluse clutch product, continue to inspect the dampers at these regular intervals and replace if necessary.

The rubber dampers = KTM part #: 78132025100 (6 are required)

See the reverse of this page for damper inspection procedure

DAMPER INSPECTION

Lay your bike on its left side, then remove the clutch cover and the following components:

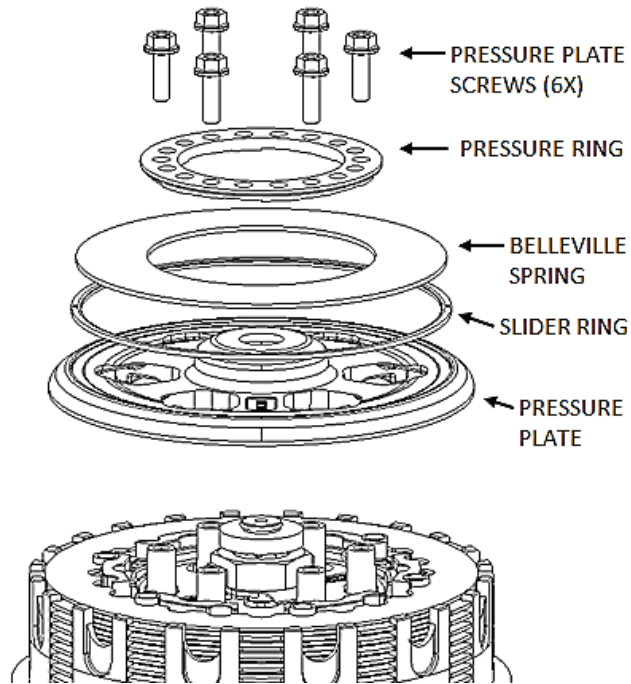

With the bike in neutral, place your thumbs on the inner hub, at the location of the embossed part numbers, and try to spin the inner hub back and forth inside the outer hub. Rekluse recommends replacing the dampers if you feel slop between the two hubs.





REKLUSE[®]

CoreManual[™]

REKLUSE MOTOR SPORTS

The Rekluse Core Manual Clutch Kit

INSTALLATION & USER'S GUIDE

Doc ID: 191-7003A

Doc Rev: 040919

OVERVIEW

- **NOTE:** If this kit is being installed in a 2-stroke bike, be advised that you may need to purchase new friction disks from KTM. See the “Install Clutch Pack” section for details.
- This kit replaces the OEM core clutch components including the center clutch hub and pressure plate with high-quality billet components designed for optimal operation specific to your bike.
- All 8 OEM friction disks will be reused, but all OEM steel drive plates will be replaced with Rekluse TEC drive plates. Also, all 6 of the OEM drive pins will be reinstalled.

NOTE: If you are installing this kit for the end user then you are required to give all documents to the end user for their reference and instruct the end user on the proper use, maintenance, and safety requirements of this product.



INSTALLATION TIPS

- Watch the “CORE EXP Auto-Clutch Installation Video” by following this QR code or visiting rekluse.com/videos.
- Read this entire document before performing any steps, so you will know what to expect.
- Be sure to use proper eye protection.
- Laying the bike on its left side allows for easy clutch access and eliminates the need to drain oil
- An air or electric impact wrench works well to remove the center clutch nut, or you can place the bike in top gear and hold the rear brake while loosening the center clutch nut with a socket
- Channel-lock pliers work best to bend the tabs of the washer up over the center clutch nut
- For optimal clutch performance Rekluse recommends using fresh, clean oil that **meets JASO-MA** oil rating requirements. Rekluse offers Factory Formulated Oil[™] developed specifically for Rekluse products. Rekluse Factory Formulated Oil is a perfect complement to any OEM or aftermarket wet clutch. Visit www.rekluse.com to learn more.

©2014 Rekluse Motor Sports
Rekluse Motor Sports, Inc.
12000 W Franklin Rd
Boise, Idaho 83709
208-426-0659
support@rekluse.com

TOOLS NEEDED

- 8mm socket
- 27mm socket
- 4mm Allen key
- Torque wrench (in-lb & ft-lb, or N-m)
- Channel-lock pliers

INCLUDED PARTS

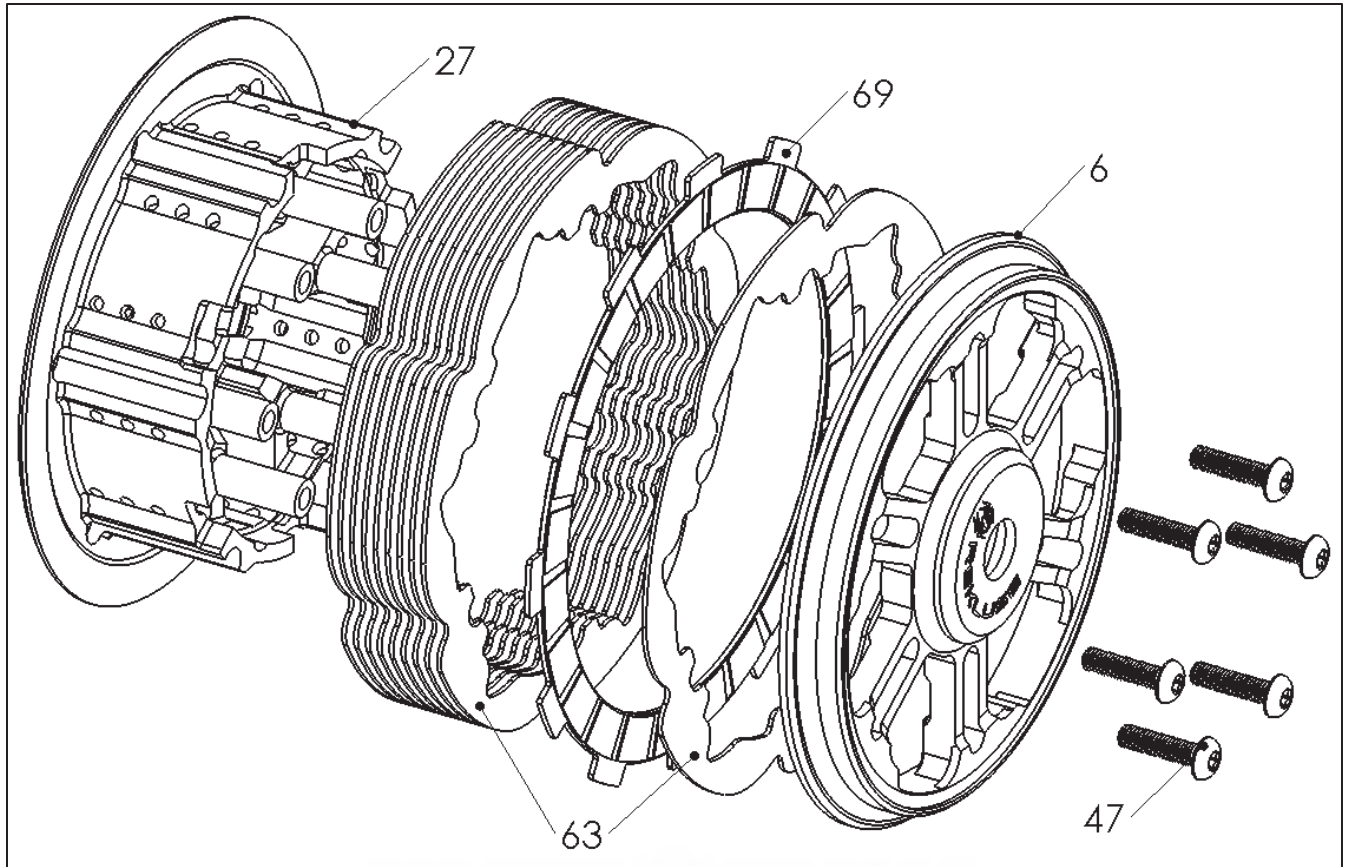

Item	Item Type	Qty
6	Pressure Plate	1
27	Outer Hub	1
47	Fastener - M5 x 20 T-25 Torx Screw (T-25 Torx bit included)	6
63	TEC Steel Drive Plate	10
69	Friction Disk (OEM 4-stroke)	1

Visit Rekluse.com/support for a full parts fiche illustration and part numbers.

BIKE PREP & DISASSEMBLY

1. Lay the bike on its left side. Catch any fuel that might drain in a suitable container. Remove the clutch cover.



NOTE: Take note of each OEM clutch cover bolts specific location as length can vary between them. Failure to replace these bolts in the proper location after clutch installation can result in damage to your motorcycle.

2. Remove the OEM parts named in the following diagram.

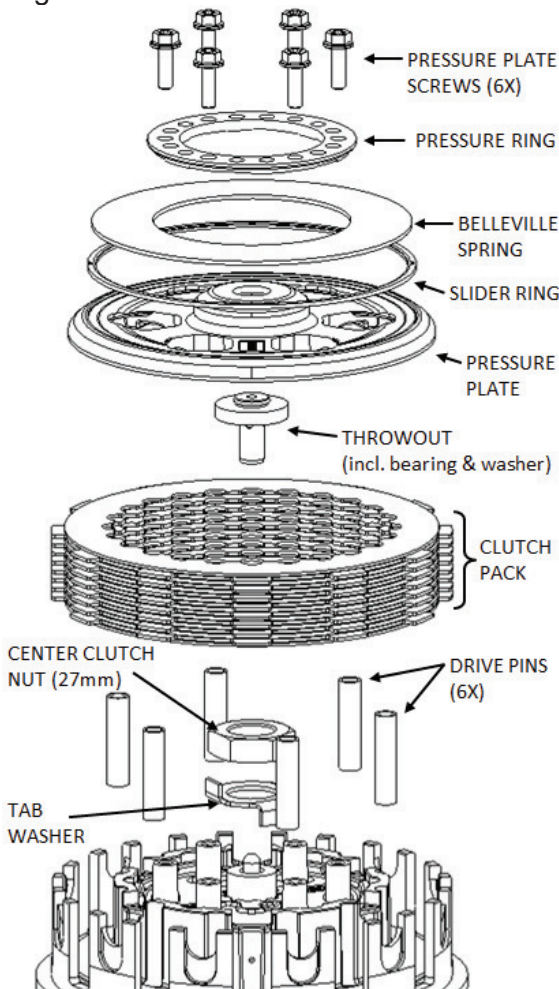

Tips:

- a. Use a hammer and large screw driver to bend down the tabs of the tab washer.

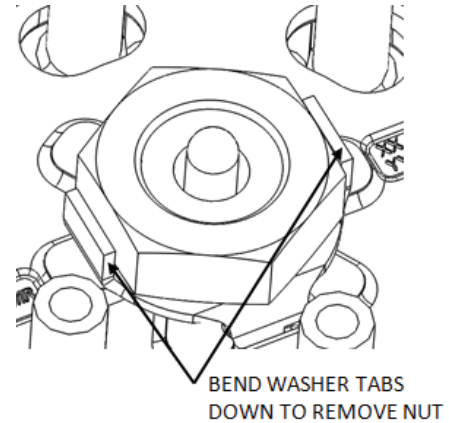

- b. Be careful that the drive pins do not fall into the engine while disassembling.

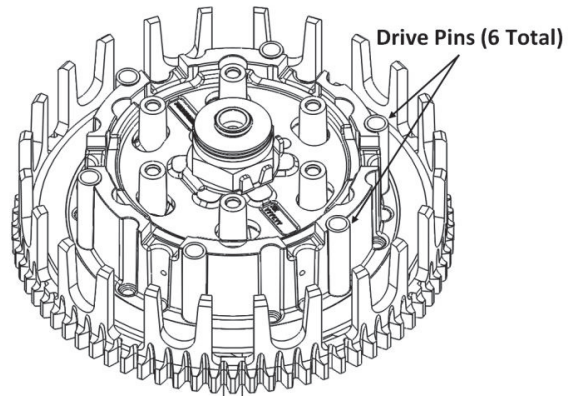

3. Separate the clutch pack.

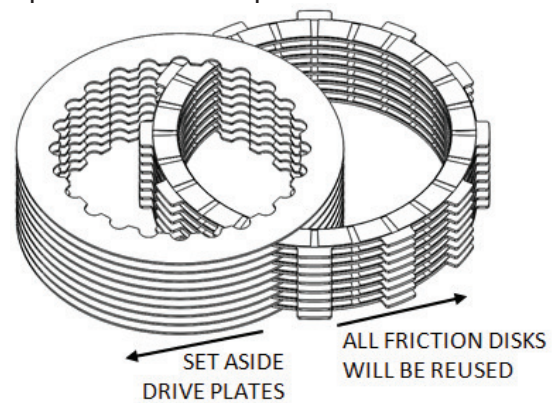

Inspect the friction disks for signs of heat or wear. Replace if they are burnt or worn.

4. Soak the included friction disk in engine oil for 5 minutes.

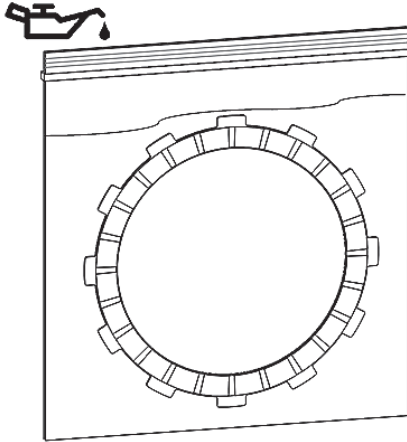

5. Remove the center hub assembly from the bike. Make sure the thrust washer is in place on the mainshaft and not stuck to the bottom of the center hub assembly.

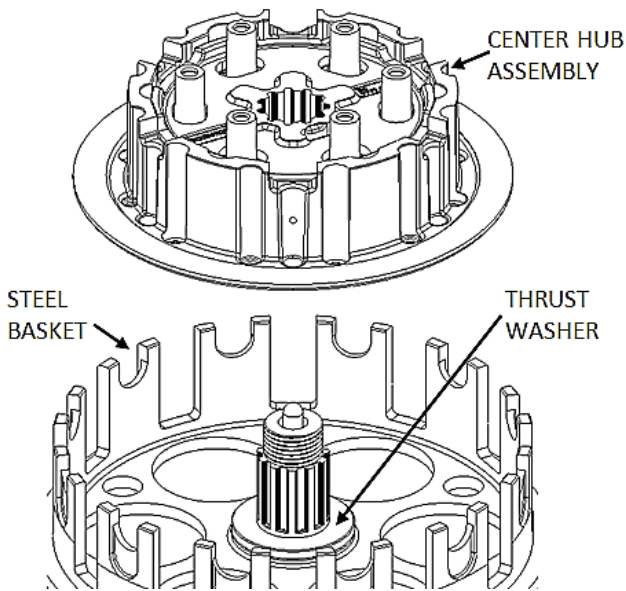

6. **NOTE:** The OEM dampers inside the center hub assembly shrink due to heat and use. Loose or sloppy dampers will shorten the life of your clutch. Inspect the dampers before proceeding and replace if necessary. Inspect the dampers using the procedure described in the “Read Me First” document, or by the following procedure.

Inspecting the dampers by hand:

With the center hub assembly in your hands, place your thumbs on the inner hub at the location of the embossed part numbers and try to spin the inner hub back and forth inside the outer hub. Rekluse recommends replacing the dampers if you feel slop between the two hubs.



7. Remove the 6 rubber dampers from the center hub assembly.

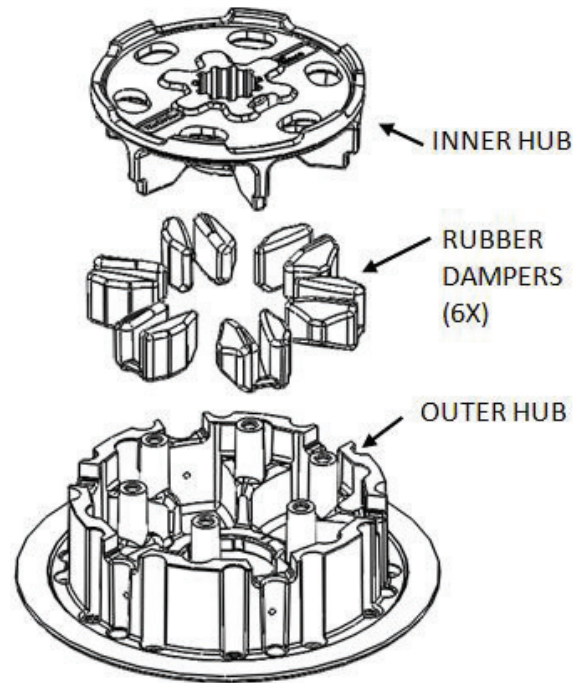

INSTALL HUBS

8. Install the 6 OEM rubber dampers and OEM inner hub onto the Rekluse Outer Hub [#27].

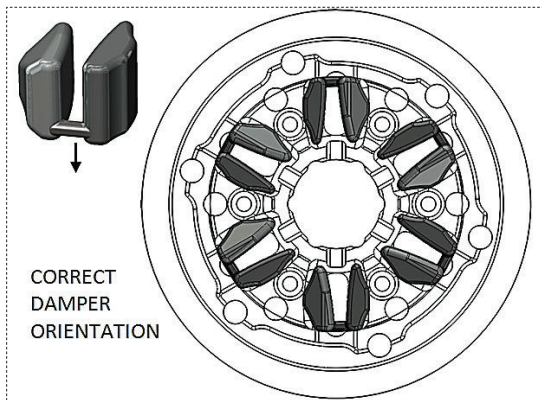
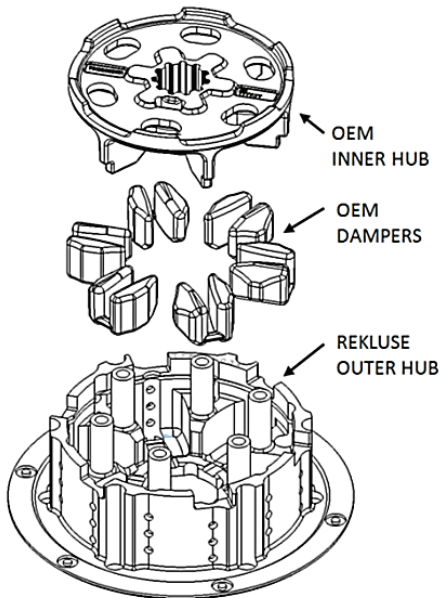

9. Install the new Center Hub Assembly into the motorcycle.

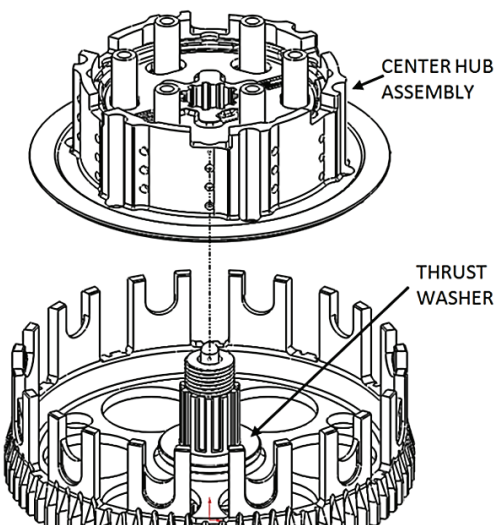

10. Reinstall the OEM tab washer and center clutch nut torquing the nut to OEM specification. Bend up **both** tabs of the tab washer using channel-lock pliers.

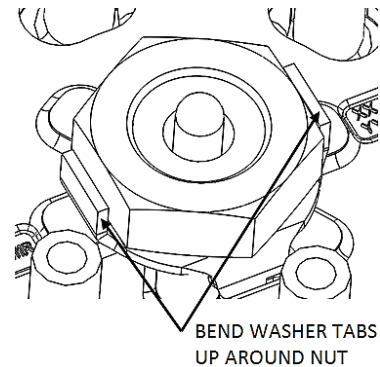

11. Seat the 6 OEM drive pins into the Rekluse outer hub.

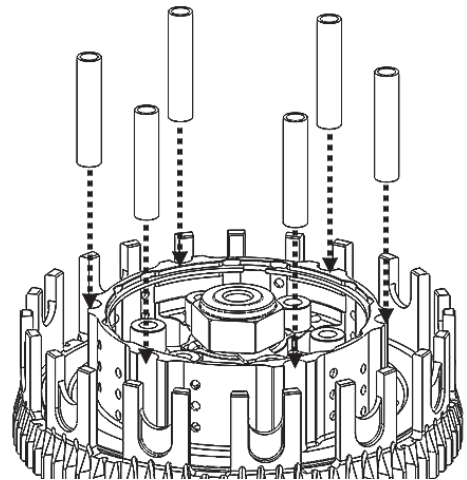

INSTALL CLUTCH PACK

2-STROKES only:

If your engine is a 4-stroke, skip to step 12.

Certain friction disks in some 2-stroke models are thicker than the 4-stroke disks, and these differences can greatly affect the overall performance of your clutch and stiffness of your clutch lever pull. The output force of the Belleville spring in your clutch is very sensitive to the clutch pack thickness. For optimal performance, purchasing 4-stroke frictions may be necessary if your 2-stroke friction disks measure to be too thick.

Using calipers, measure the thickness of **all 8x** OEM friction disks stacked together to meet the following guidelines before installing in the bike:

1. If the measurement is less than .624" (15.86mm), continue to the next step.
2. If the measurement is greater than .624" (15.86mm), you will need to purchase **8x** 4-stroke friction disks which are thinner than your 2-stroke disks.

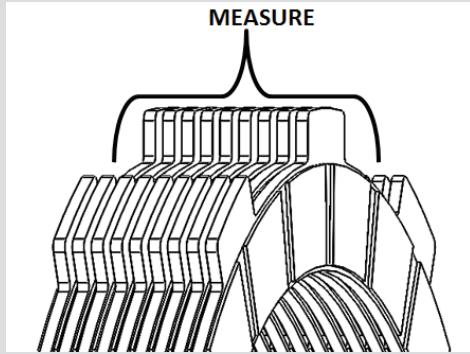

4-stroke friction disk = **KTM Part # 59032011100**

12. Install the first TEC drive plate in the orientation shown (all drive plates will follow this orientation).

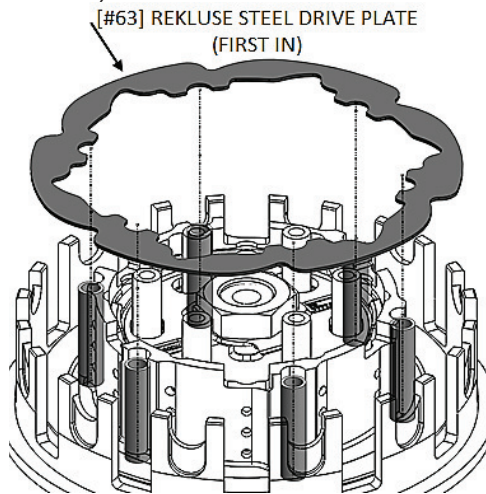

NOTE: Proper orientation of the drive plates is *critical* for optimal clutch performance. If you install them backwards, the clutch will still function but will lack proper modulation performance.

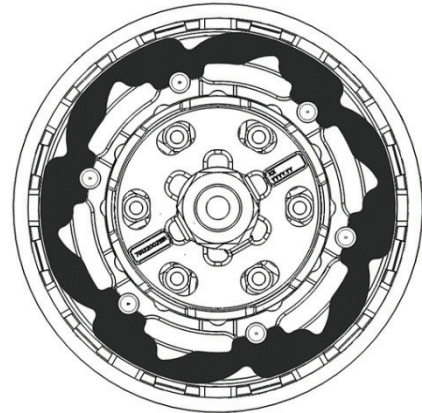
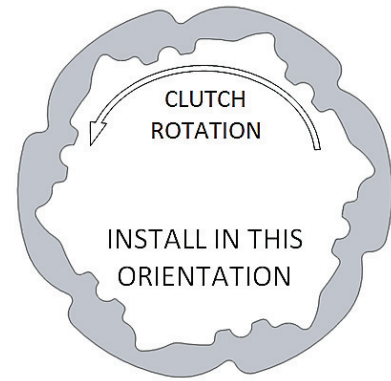

13. Install the rest of the clutch pack, noting the number and order of plates below.

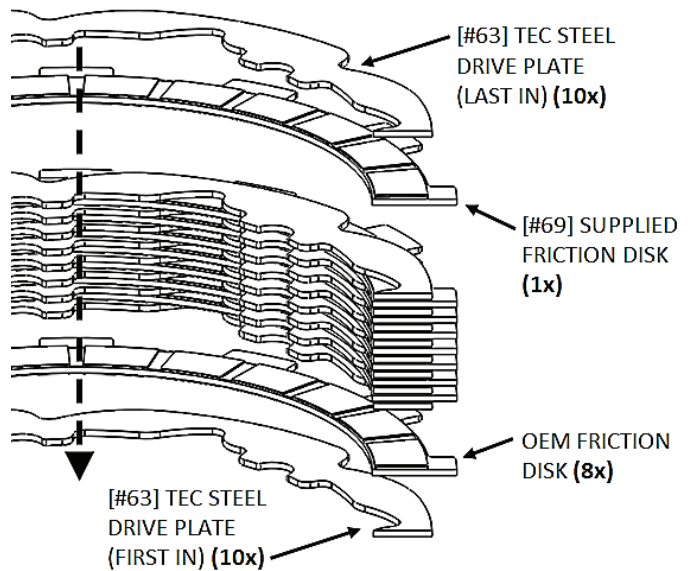

14. Reinstall the OEM throwout.

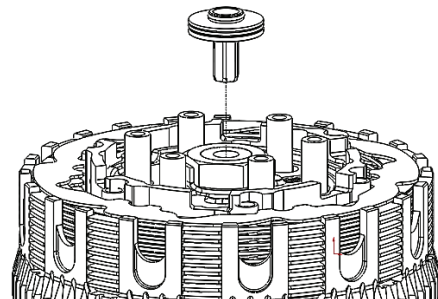

PRESSURE PLATE INSTALLATION

15. Install [#6] Pressure Plate.

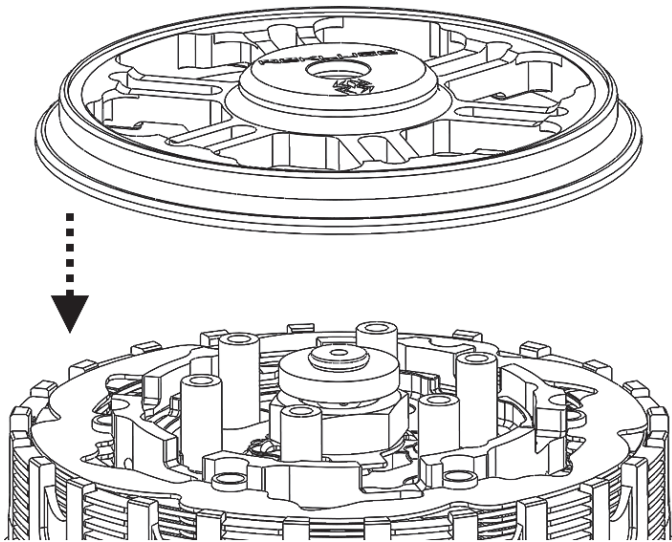

16. Install the OEM slider ring and Belleville spring.

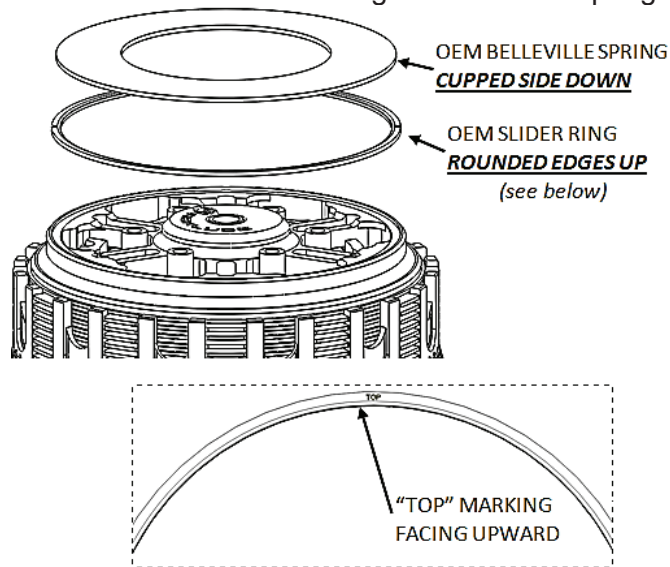

17. Install the OEM pressure ring followed by the Rekluse Pressure Plate Screws [#47].

WARNING:

DO NOT reuse the stock screws, or clutch cover interference will occur!

DO NOT over-torque the screws, or damage to the screw heads will occur!

NOTE: There are 3 possible settings on the OEM Pressure Ring. Rekluse recommends setting II (4-strokes) or Y/II (2-strokes) for optimum clamping force and performance.

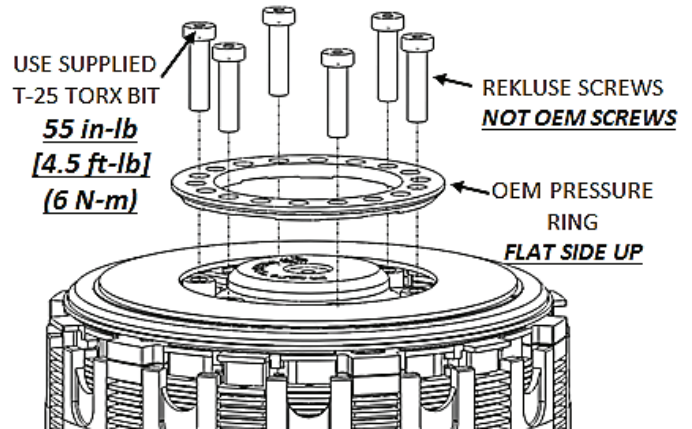

18. Reinstall the OEM clutch cover. Install the clutch cover bolts in their proper OEM location and Torque the cover bolts to OEM specification – 7.4 ft-lb (10 N-m). If you purchased the Rekluse clutch cover, reuse the OEM cover gasket and oil plug when installing.

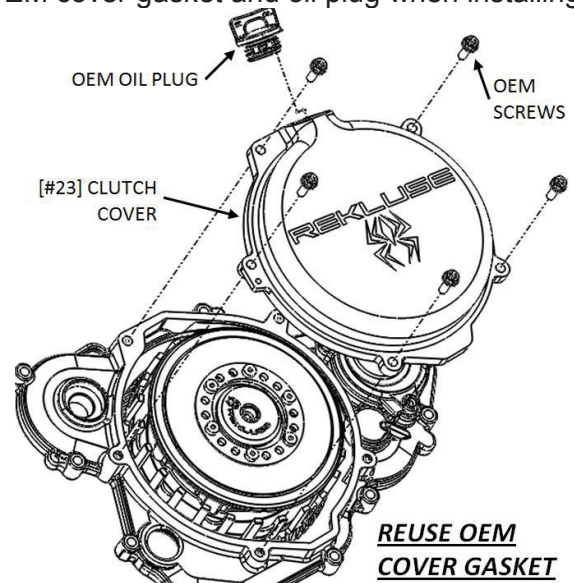

WARNING

Failure to install the OEM clutch cover bolts back in their proper location can result in damage to your motorcycle.

-
19. Optional: If you purchased the Rekluse Slave Guard accessory, install it now using the instructions in the kit.

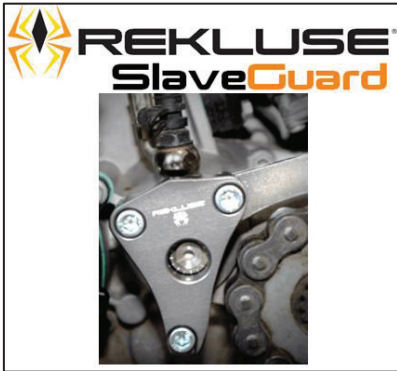

MAINTENANCE

- To prolong the life of the clutch, inspect your rubber hub dampers **every 20 hours**. Replace the dampers if the interaction between the two hubs is loose or sloppy.
See the "Read Me First" page for inspection procedure.
- Keep up with regular oil changes as per the bike manufacturer's recommendations. For optimal clutch performance Rekluse recommends using fresh, clean oil that **meets JASO-MA** oil rating requirements. Clutch function and longevity depends on oil quality.
- Inspect all of your clutch parts **every 40 hours** for signs of wear or excessive heat, and replace components as necessary

APPENDIX: CONVERTING CSS CLUTCH TO DDS CLUTCH

Doc ID: 195-7084A

Doc Rev: 020714

The “CSS” (Coil Spring Steel) clutch is standard in 2013 and newer KTM 250/350 SX-F and XC-F motocross models, as well as the 2014 and newer Husqvarna FC 250.

In contrast, the “DDS” (Diaphragm Damped Steel) comes standard in the enduro models of the same bike sizes: 250/350 XCF-W and FE 250/350.

CSS Clutch



DDS Clutch



Because the CSS clutch is an undamped clutch system, some riders opt to install the DDS clutch instead. The DDS clutch will fit inside the same space and will have adequate clearance under the OEM or Rekluse clutch cover.

To complete the conversion, the following OEM KTM/Husqvarna components will need to be purchased in addition to the Rekluse clutch kit that you will be installing. See reverse of this page for the fiche diagram.

OEM Parts Needed: Convert 250/350 SX-F CSS to DDS Core			
KTM Part #	Part Description	QTY	Retail Price
78132002111	HUB (inner)	1	\$58.39
78132025100	DAMPING RUBBER	6	\$16.14
78132004000	SLEEVE - 7.5 x 33.4mm (a.k.a. Hub Pin)	6	\$16.14
78132013000	WASHER - 112x118x1.5mm (Spring Slider for Belleville)	1	\$7.39
56532018000	LOCK WASHER	1	\$4.49
0936181505	HEXAGON NUT - M18 x 1.5mm (replaces taller nut in SX-F)	1	\$6.29
77232009000	THRUST WASHER - 5.1mm thick (replaces 3mm washer in SX-F)	1	\$7.19
78132006100	SPRING RING (Adjustable Spring Plate)	1	\$33.89
78132005000	BELLEVILLE SPRING 71x115x1.5mm	1	\$27.39

Compatible clutch kits from Rekluse for the DDS clutch in these bikes are:

- RMS-7084 Core Manual *(Performance Manual Clutch Kit)*
- RMS-7785 Core EXP *(Performance Auto Clutch Kit –Includes Clutch Cover)*
- RMS-335 Clutch Cover

OEM Parts Needed for Conversion

C127753210 > CLUTCH			
<input checked="" type="checkbox"/> Show price			
PARTS	REPAIR TIME	SPECIAL PARTS	
1	77232001073	OUTER CLUTCH CPL.	1
2	78132002008	% INNER CLUTCH HUB	1
3	78132003000	PRESSURE PLATE	1
4	78132002111	HUB	1
5	78132025100	DAMPING RUBBER	6
6	78132004000	SLEEVE 7,5X33,4	6
7	78132013000	WASHER 112X118X1,5	1
9	59032010200	INTERMEDIATE DISC 1,4MM 2002	7
10	59032010100	INTERMEDIATE DISC 1MM 2002	2
11	59032011100	LINING DISC 2MM 04	8
13	77232015000	INNER RING	1
16	77230029000	NUT PRIMARY WHEEL	1
18	56532018000	LOCK WASHER	1
19	0936181505	HEXAGON NUT DIN0936-M18X1,5 R.	1
20	77232009000	WASHER 21,8 X 37 X 5,1	1
23	77232023024	PRIMARY GEAR 24T.	1
24	77232062000	GASKET F. OUTPUT CYLINDER	1
25	0770300015	O-RING 30,00X1,50 NBR 70	1
30	78132010110	CLUTCH KIT 350 EXC-F 12-14	1
50	78132006100	SPRING RING	1
53	77232054000	PUSH ROD	1
54	78032057000	PRESSURE PIECE	1
71	0025060166	HH COLLAR SCREW M6X16 TX30	2
72	0025060356	HH COLLAR SCREW M6X35 TX30	1
73	0025050166	HH COLLAR SCREW M5X16 TX30	6
75	50329050000	VENT INJEKTION HYDR. CLUTCH	1
80	78132005000	BELLEVILLE SPRING 71X115X1,5 I	1
81	77232066000	PISTON CPL.	1
82	77232061044	OUTPUT CYLINDER CPL.	1
85	54832067000	O-RING	1
86	54832069000	PRESSURE SPRING	1

