



INSTALLATION & USER'S GUIDE

CoreManual Clutch
for Cobra 65

Doc ID: 191-7013A
Revision: 040919

Table of Contents

OVERVIEW	2
INSTALLATION TIPS	3
TOOLS.....	4
INCLUDED PARTS	5
DISASSEMBLE CLUTCH.....	6
ASSEMBLE THE BASKET	11
CLUTCH INSTALLATION	13
INSTALL THE CLUTCH COVER	19
BLEED THE CLUTCH LINE	22
MAINTENANCE.....	25
Disk inspection examples.....	25
TROUBLESHOOTING	26
Performance issues.....	26
Clutch noise.....	27
NEED ADDITIONAL HELP?.....	28

OVERVIEW

This kit replaces many of the OE (Original Equipment) or “stock” clutch parts with Rekluse high quality billet components designed specifically for your bike model. The following is a summary of what is replaced:







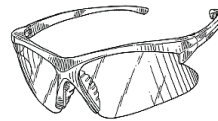

- This kit will replace all the OE drive plates with Rekluse steel drive plates.
- OE center hub and pressure plate components are replaced with Rekluse Core components.
- The bike’s OE basket is replaced using the Rekluse basket. This Rekluse basket is taller than the OE one and is a necessary component to achieve overall clutch performance and improve the life of the clutch.

INSTALLATION TIPS

- Read the separate included Safety Information document before operating the vehicle with the product installed.
- Read this entire document before performing any steps.
- If you install this product for a customer or another person, instruct them to read the **Safety Information** document and the **Installation and User Guide** before operating the bike with the product.
- Protect eyes and skin – wear safety glasses and work gloves.
- Lay the motorcycle on its left side when replacing the clutch. This makes the clutch work easier and eliminates the need to drain the oil. Catch any fuel that may drain from the bike.
- Use the torque values listed in the instructions. Otherwise, use the torque specifications found in your OE service manual.
- For optimal clutch performance Rekluse recommends using fresh, clean oil that **meets JASO-MA** oil rating requirements. Rekluse offers Factory Formulated Oil™ developed specifically for Rekluse products. Rekluse Factory Formulated Oil is a perfect complement to any OEM or aftermarket wet clutch. Visit www.rekluse.com to learn more.
- The Rekluse basket is compatible with the CoreEXP auto clutch, CoreManual manual clutch, and the OE clutch.
- **REPLACEMENT PARTS:**
Rekluse recommends replacing the clutch cover gasket and clutch cap O-ring whenever they are removed from the bike. (The gasket and O-ring can be reused if they are in good condition.)
 - Clutch cover gasket: Cobra part #ECC60016
 - Clutch cap gasket: Cobra part #ZCC60013



TOOLS

 <p>10 mm</p>	 <p>8 mm</p>		
10 mm socket	8 mm socket	Metric Wrench	Torque Wrench
			
Pick	Fluid Catch Container	14 mm socket	Hammer
 <p>5 mm</p>	 <p>4 mm</p>		 <p>3 mm</p>
5 mm Hex key	4 mm Hex key	3 mm Hex bit	3 mm Hex key

INCLUDED PARTS

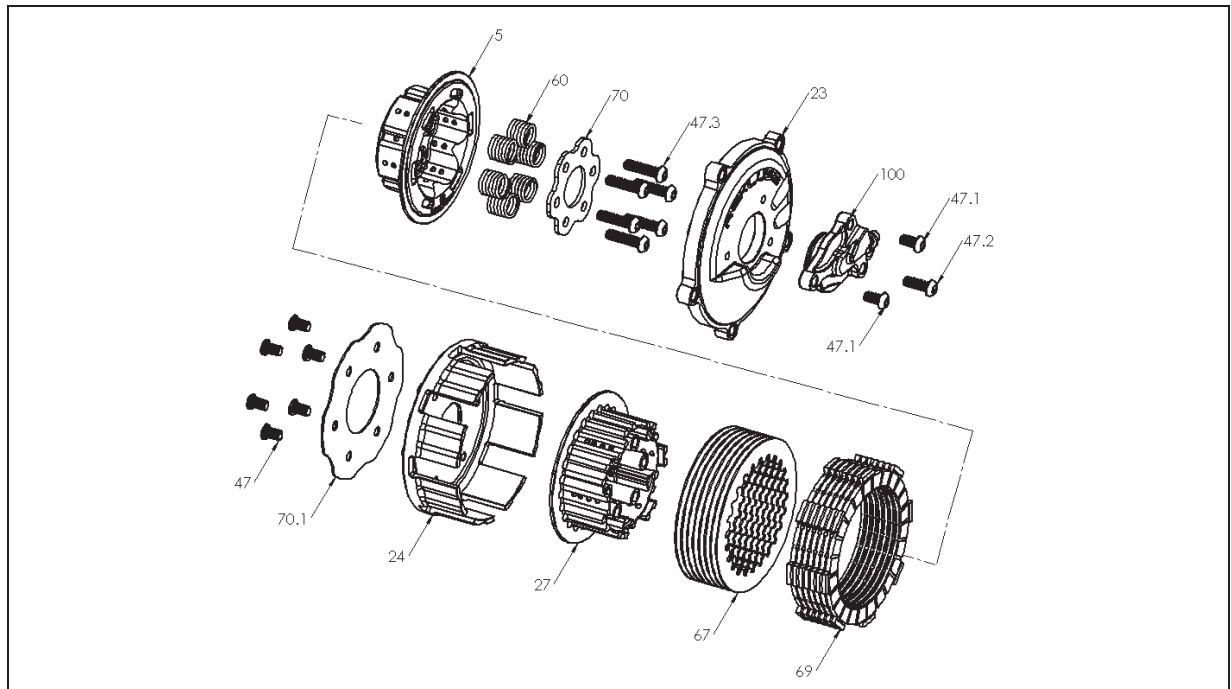

Item	Description	Qty.
5	Center clutch hub	1
23	Clutch cover	1
24	Basket	1
27	Pressure plate	1
47	Low-Head hex screws, Basket	6
47.1	Button-head hex screws, Slave Cylinder	2
47.2	Button-head hex screw, Slave Cylinder	1
47.3	Button-head hex screws, Push Plate	6
60	Pressure plate springs	6
67	Steel drive plates	8
69	Friction disks	7
70	Spring push plate	1
70.1	Basket backing plate	1
100	Slave cylinder assembly, non-adjustable	1
Not shown	Drill Bit – ¼ inch	1
Not shown	Loctite ®	1

Visit www.rekluse.com/support for a full parts fiche illustration and part numbers.

DISASSEMBLE CLUTCH

1. If your bike is carbureted, turn the fuel petcock to “OFF.”
2. Shift the transmission into the highest gear.
3. Lay the bike on its left side. With a suitable container, catch any fuel that might drain from the carburetor tubes.
4. Using an 8 mm hex key, remove the break pedal from the frame of the bike (A).
5. Using a 4 mm hex key, remove the kick-start lever (B).

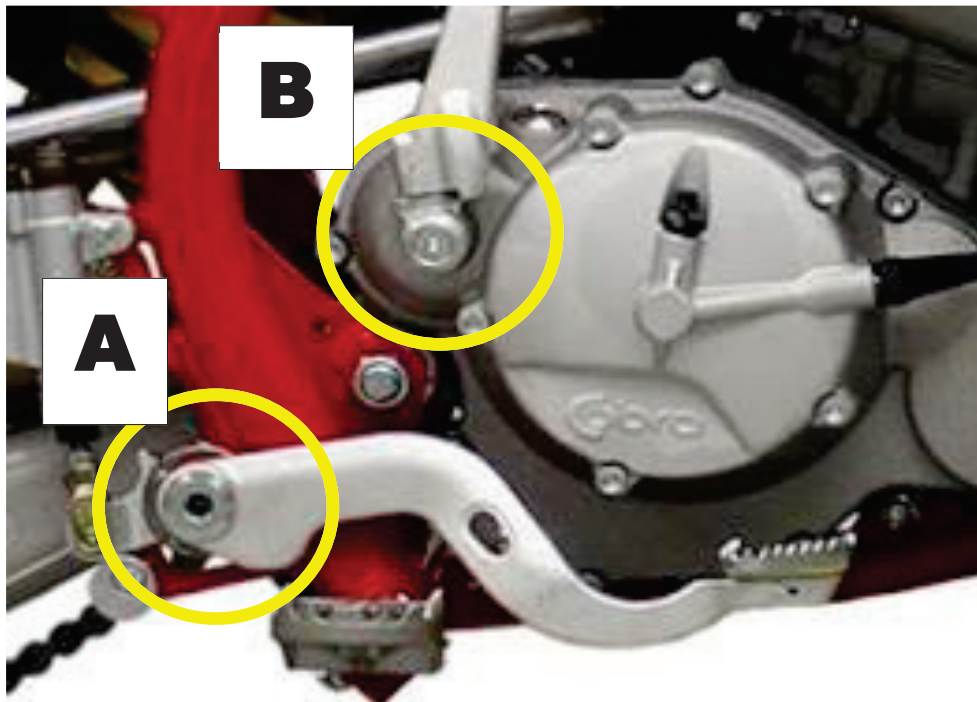
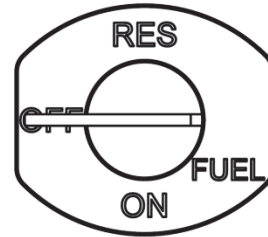

6. Using a 5 mm hex key, remove the bolts on the clutch case cover. Remove the clutch cap and case cover as one unit. **Pay close attention to the length and location of the OE screws when removing them so they can be returned to their same location.**

⚠ CAUTION

The two screws in the oil filter location (toward the front of the bike) are longer than the rest. These **MUST** be replaced in their exact location when the clutch cover case is reinstalled.

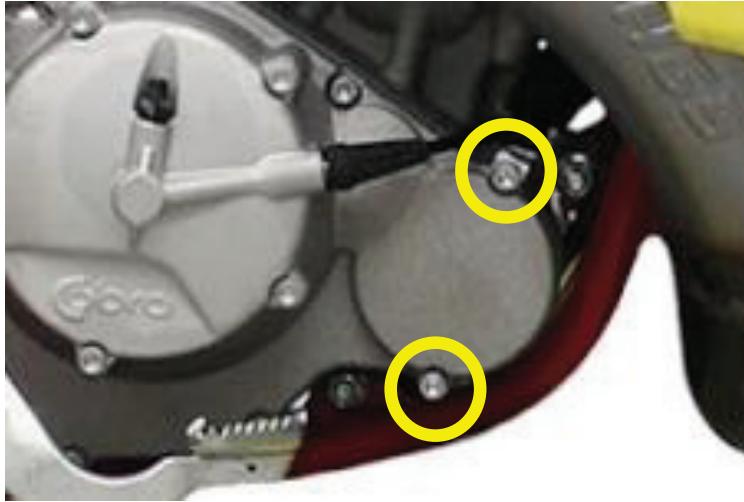

7. Remove the throw-out assembly, then using a 5 mm hex key, remove the OE pressure plate spring screws, spring plate, and springs.

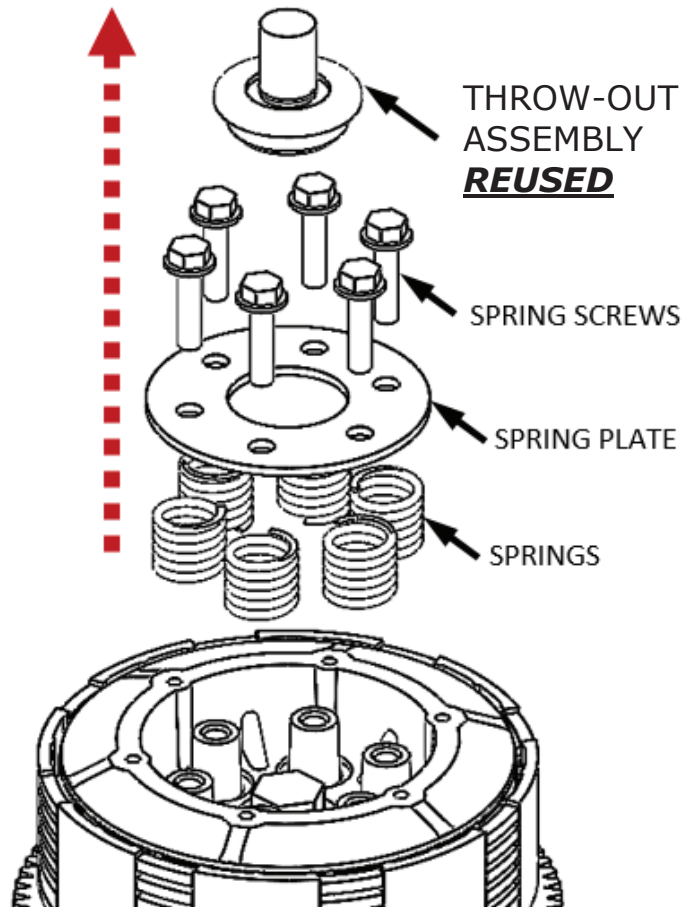

8. Using a 14 mm socket, remove the center hub bolt. Then, lift the core of the clutch out by gripping the spring posts and pulling upward.

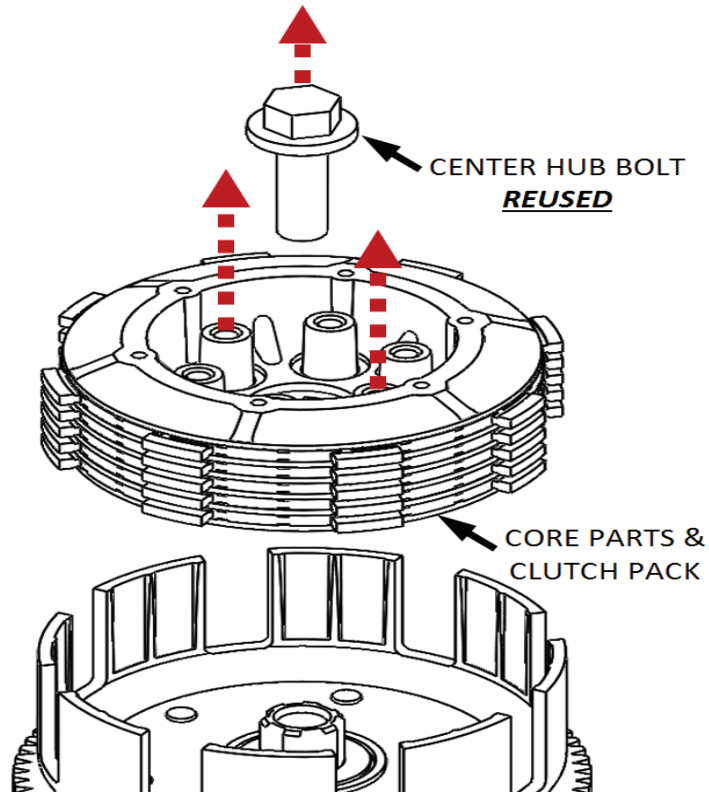

9. Inspect the OE friction disks. Replace if worn out or burnt.
(Replacements can be purchased from Rekluse or your dealer.)

10. Remove the thrust washer followed by the basket assembly.

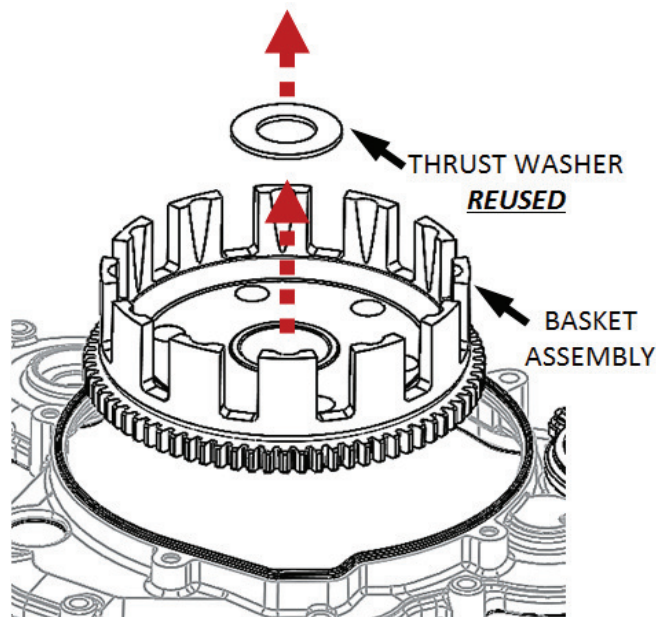

Note: If the thrust washer is not in the basket, it is likely stuck to the backside of the hub that was removed in the previous step.

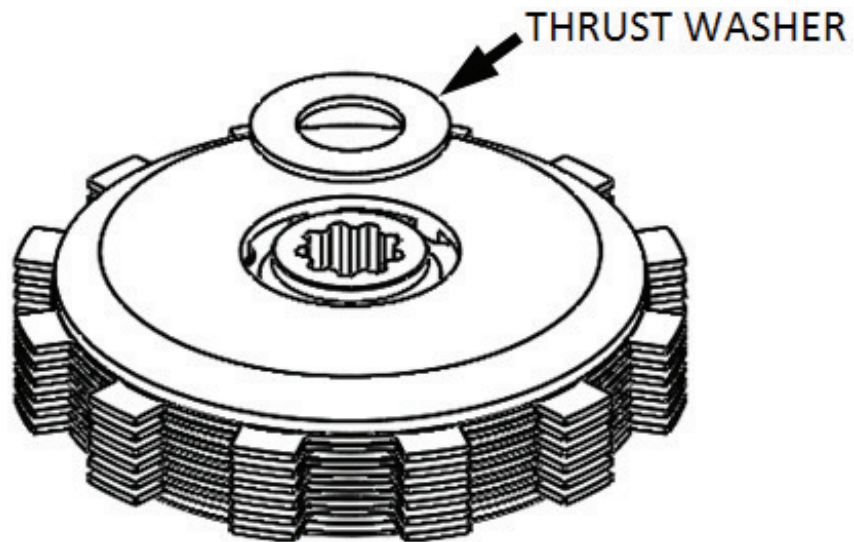

11. Ensure that the mainshaft collar (which the basket rotates on) remains on the mainshaft in the engine.



12. Set the OE basket assembly on a workbench with the ring gear facing upward. Using a center punch and hammer, punch a divot into the center of each of the rivet heads.

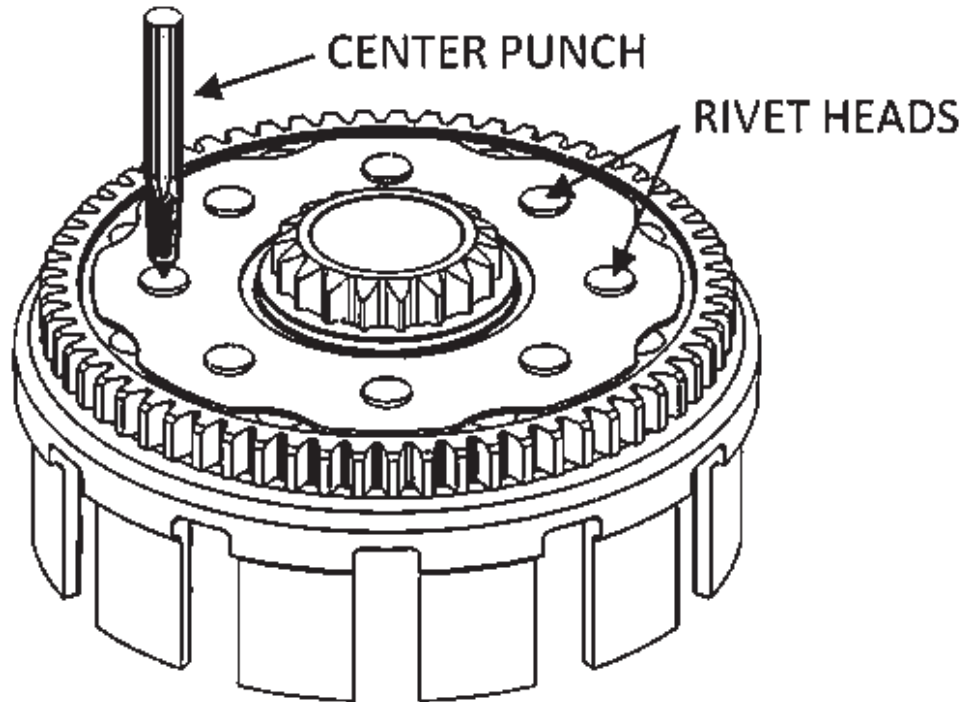

13. Using the provided drill bit, drill the heads off each rivet, so that the backing plate can be removed from the assembly.

Note: Set your drill to 300-400 RPM and use proper cutting fluid or oil for best results.

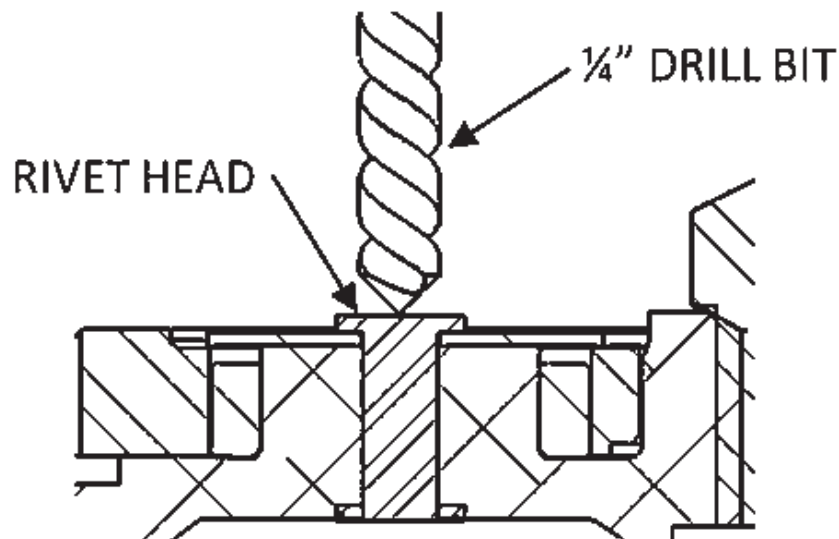

14. Carefully pry off the backing plate and remove the ring gear and rubber dampers from the basket. They will be reused. The OE basket and backing plate will not be reused.

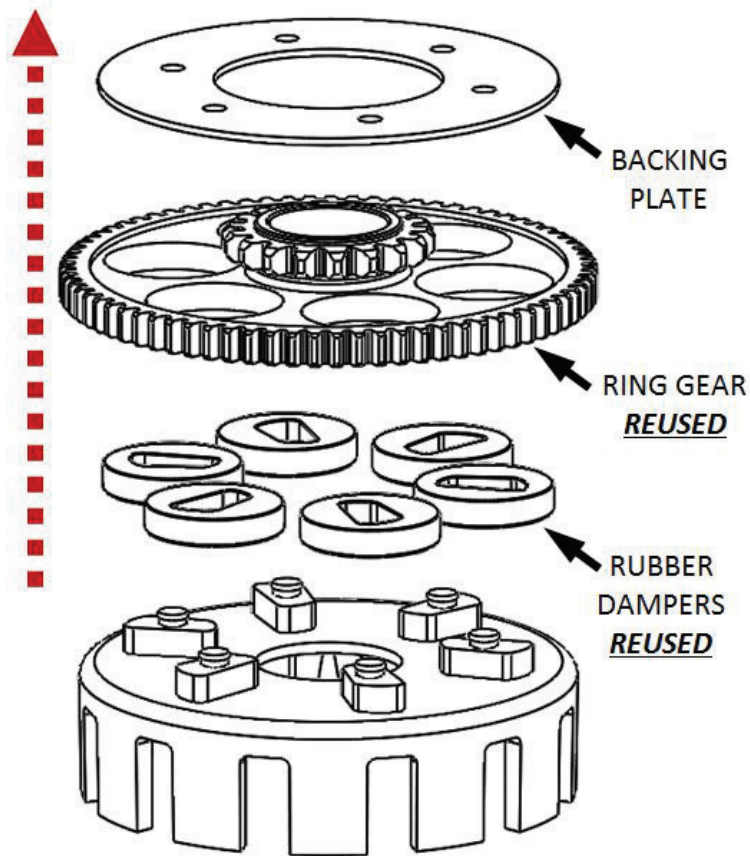

15. Clean the rubber dampers and ring gear of all grit and rivet chips leftover from drilling.

ASSEMBLE THE BASKET

1. Place the new Rekluse clutch basket, tang side down, onto a workbench.
2. Install the rubber dampers onto the clutch basket. Be sure to match the damper shape to the orientation of the posts on the basket.
3. Install the ring gear on top of the dampers, then install the Rekluse basket backing plate.

4. Using the provided Loctite® on the screw threads, screw the clutch basket assembly together.
5. Using a 3 mm hex key, tighten the basket screws in small increments in a star pattern. Torque the basket screws in a star pattern to **80 in-lb (9 N-m)**.

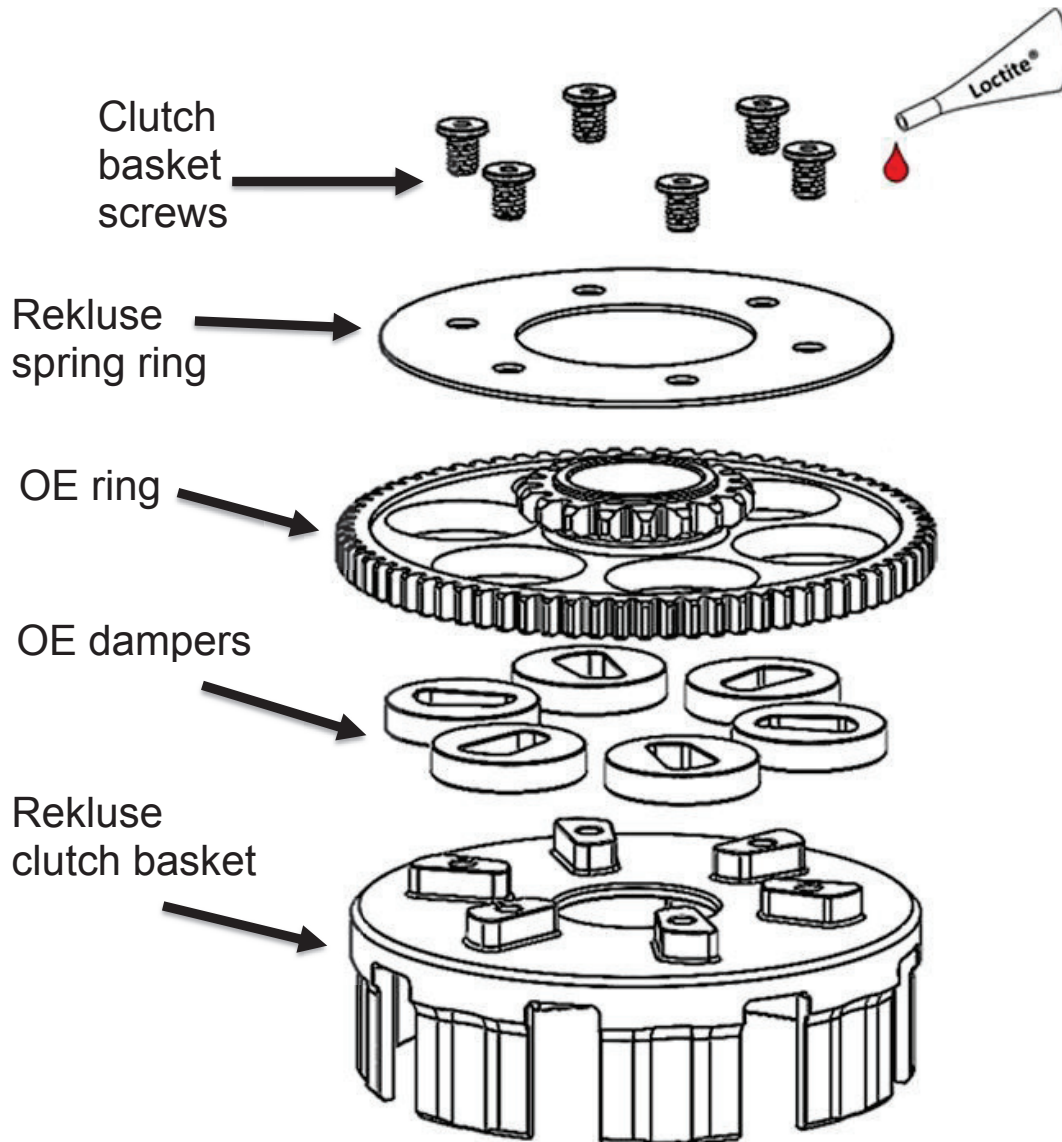

⚠ CAUTION

*It is **critical** that you apply Loctite and stake the ends of the screws or they can back out. Rekluse is not responsible for engine damage that may be caused by screws that back out.*

6. Using the hammer and center punch, stake the ends of the screws where they protrude through the inside of the clutch basket. *Be sure to stake the screws... **DO NOT** stake the aluminum basket.*

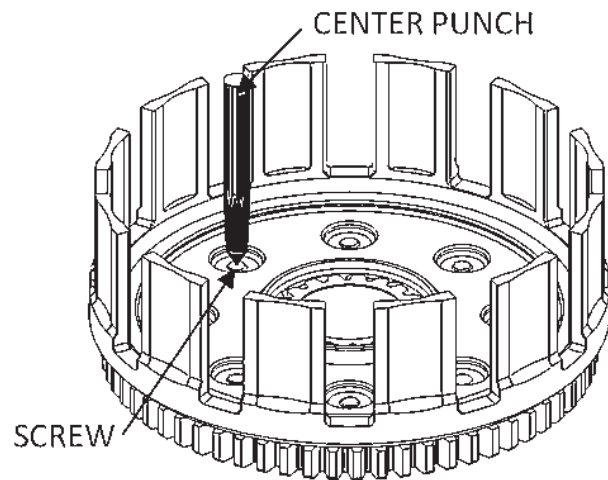

CLUTCH INSTALLATION

Cross-Section of the clutch pack:

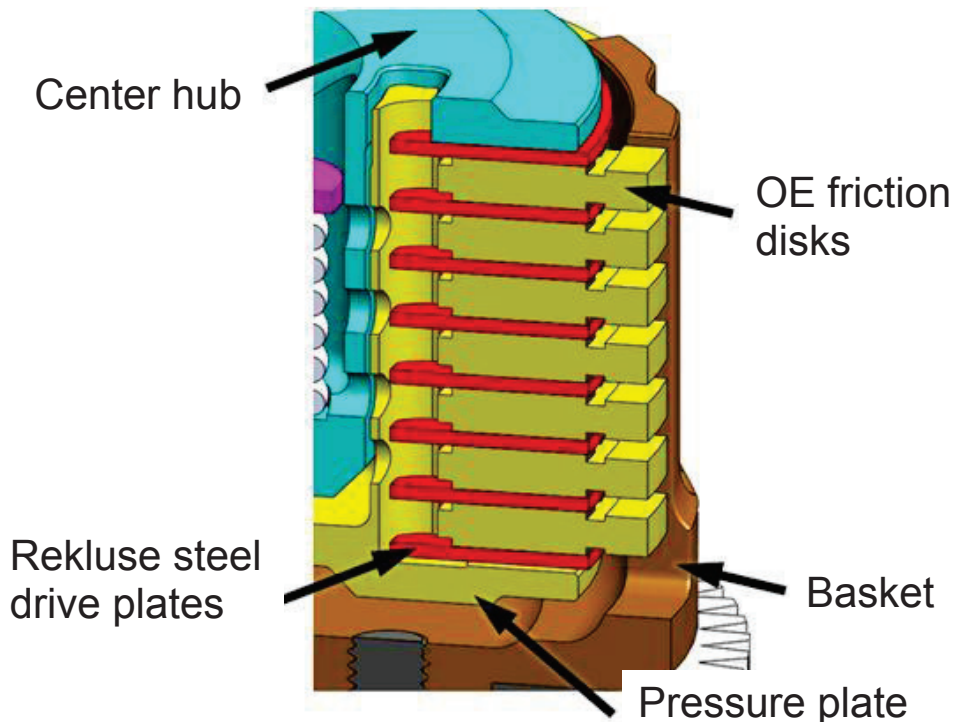

1. Install the Rekluse clutch basket over the mainshaft collar onto the mainshaft in the bike. *Be sure to line up the gear teeth with the crank and kick-starter gears.*

Note: *To get the ring gear teeth to properly mesh with the crank and kick-starter gears, gently rotate the basket until it drops in and the teeth all mesh. **DO NOT** force the basket in or damage may occur.*

2. Install the OE thrust washer.

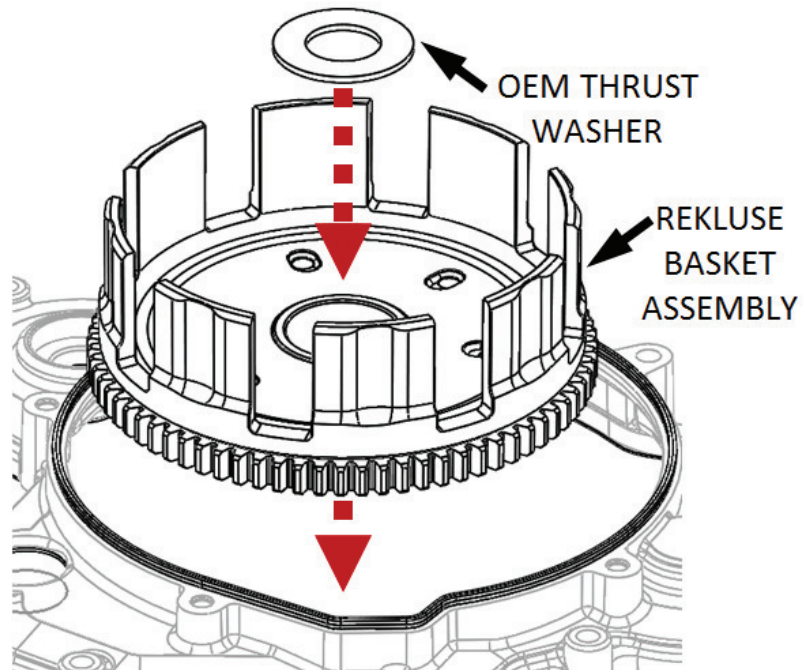

3. Install the Rekluse pressure plate in into the basket. It will fit loosely in the basket until the clutch plates and hub are installed in the following steps.

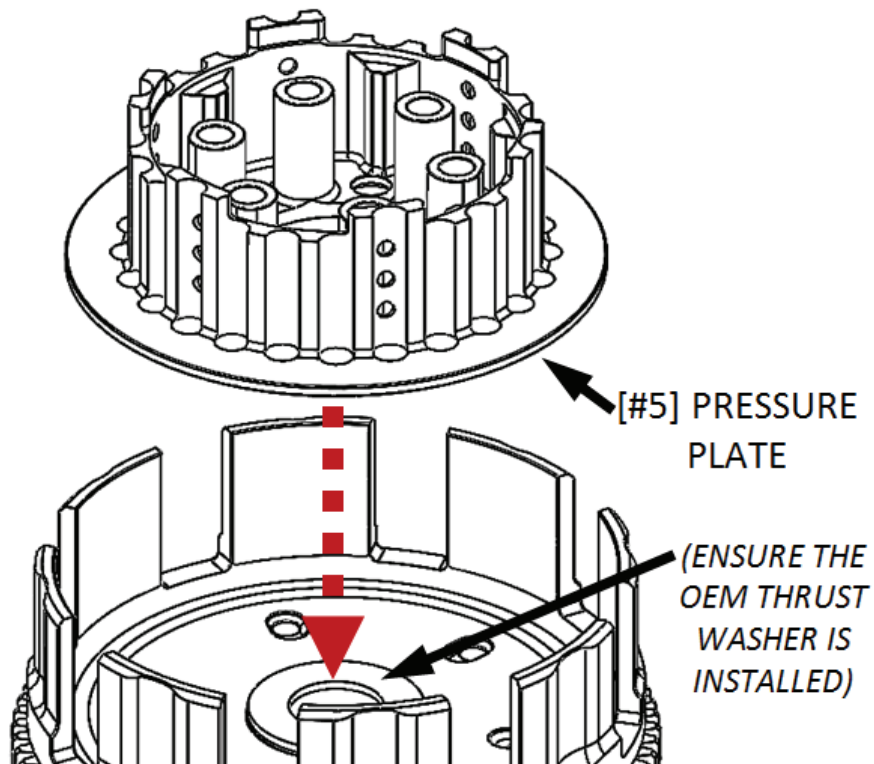

4. Install a Rekluse steel drive plate first. Then alternate the included friction disks with the Rekluse steel drive plates, ending with a steel drive plate.

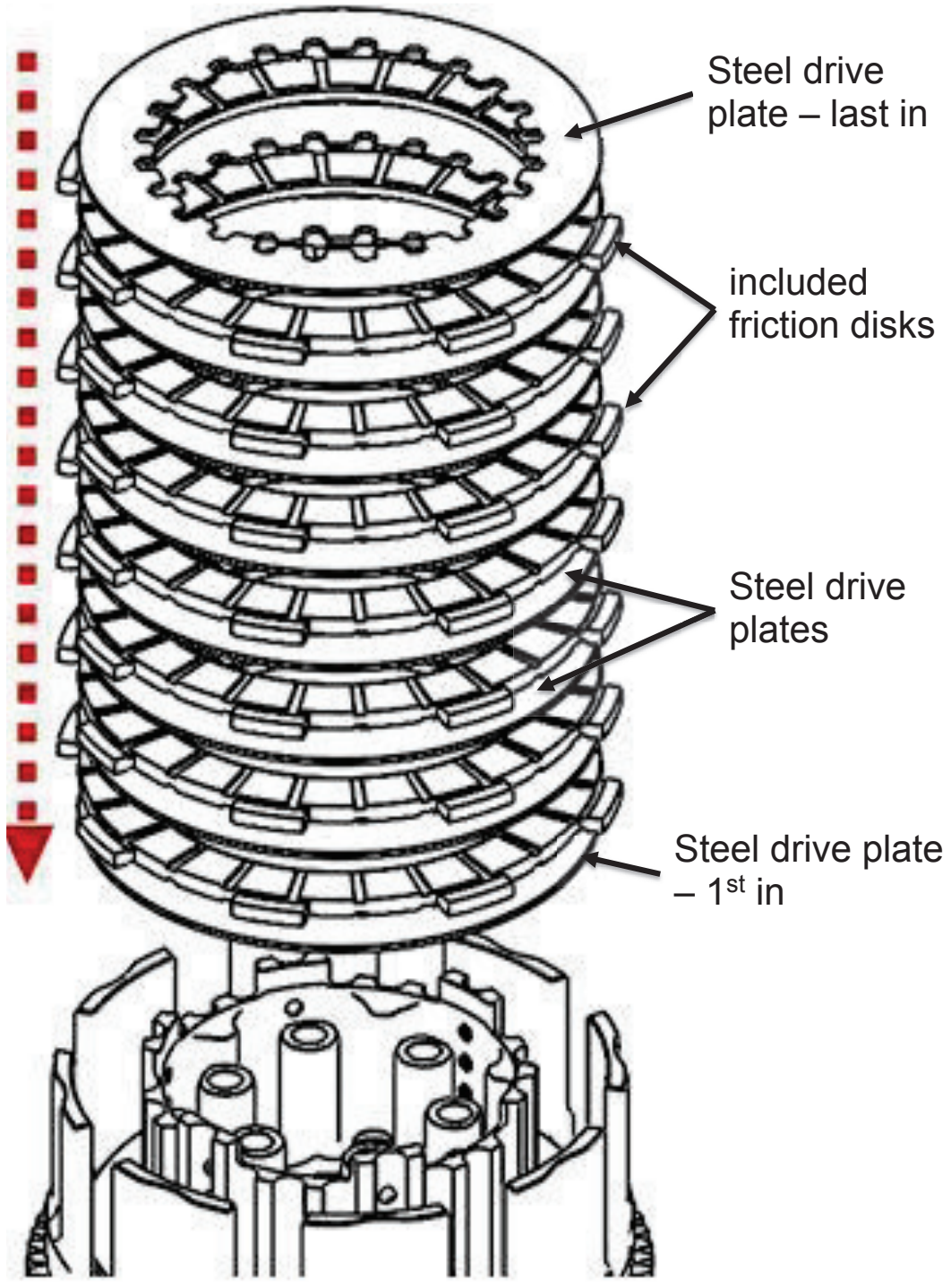

5. Install the Rekluse center clutch hub onto the clutch pack.

Note: To get the spline in the hub to line up with the mainshaft spline, gently rotate the hub back and forth while installing it until the splines mesh and the hub drops into place. **DO NOT** force the hub into place or damage will occur.

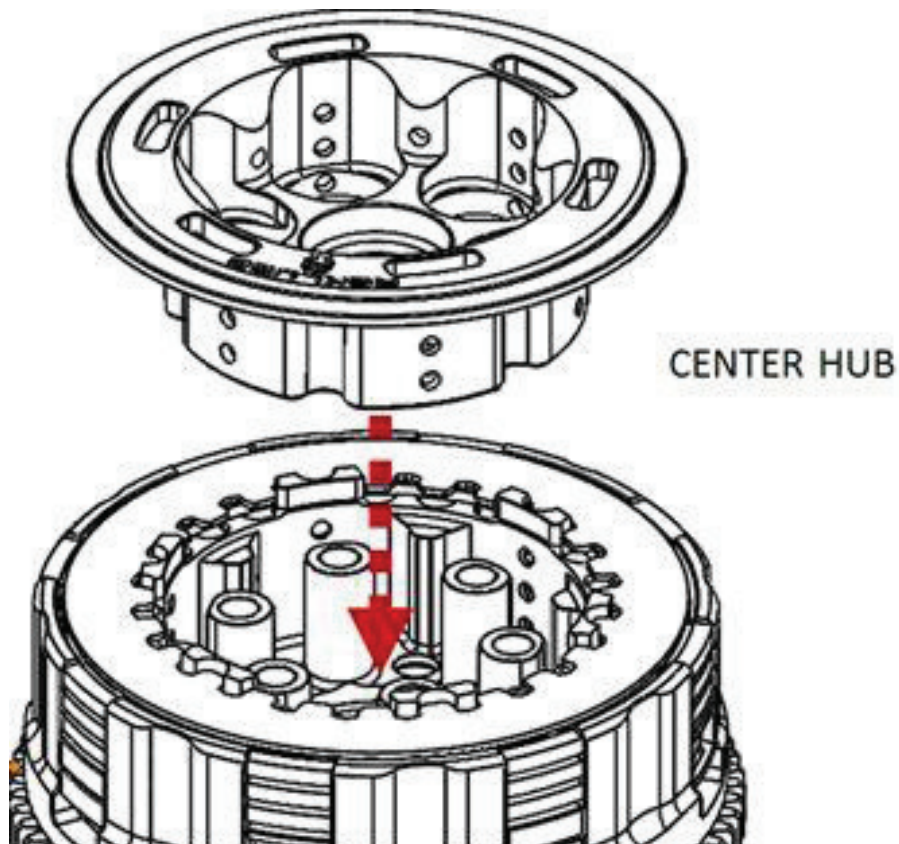

6. Install the new pressure plate springs, followed by the Rekluse spring plate screws.

CAUTION

DO NOT reuse the OE screws. They cause interference with the clutch cover.

7. Use the 3 mm hex bit to carefully tighten the screws in small increments in a star pattern to evenly lift the pressure plate.

8. Torque the screws to **7.5 ft-lb (10 N-m)** in a star pattern.

NOTE: Shifting the transmission into 5th gear and holding the rear wheel or rear brake pedal helps keep the shaft from rotating when tightening the screws and center hub bolt.

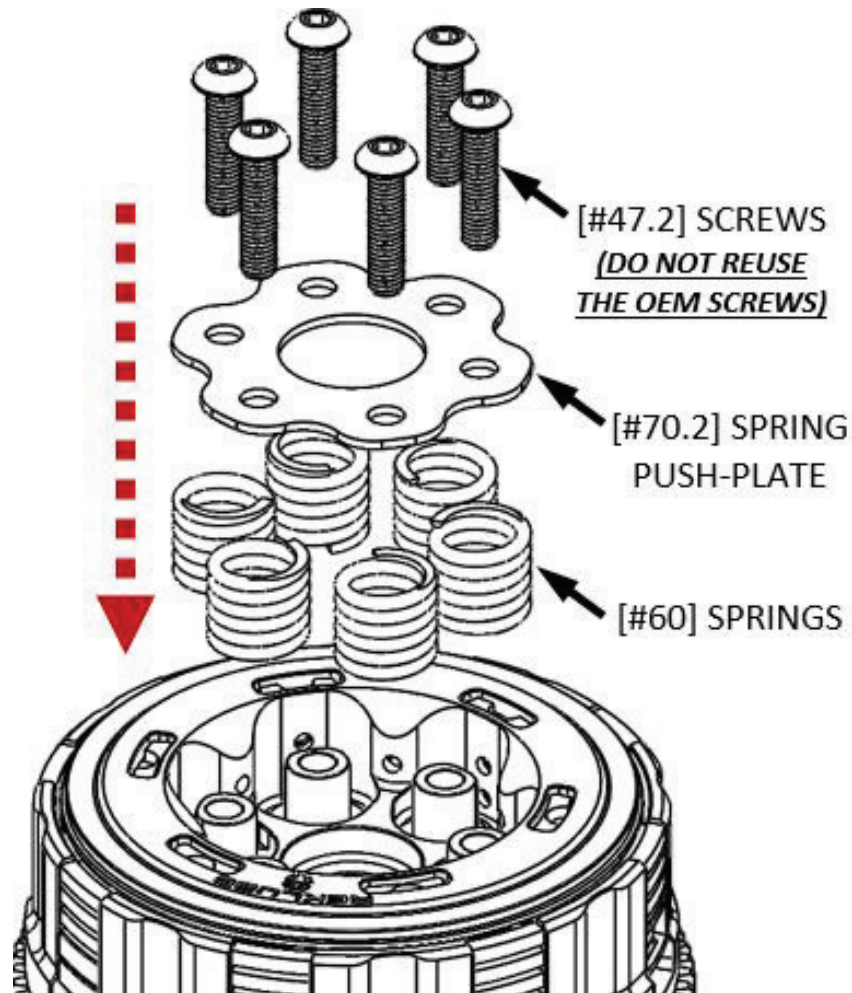

9. Clean and dry any oil or debris from the threads of the OE center hub bolt, then apply the supplied Loctite® to the threads of the bolt.
10. Install the bolt into the mainshaft, and torque to **40 ft-lb (54 N-m)** using a 14 mm socket.

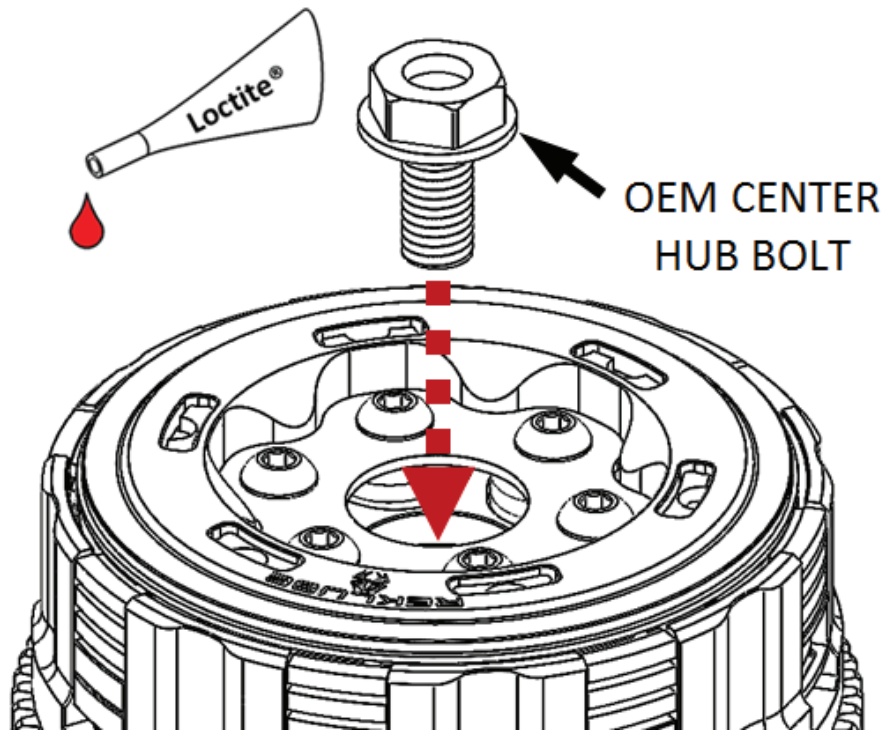

11. Reinstall the OE throw-out assembly into the spring push plate.

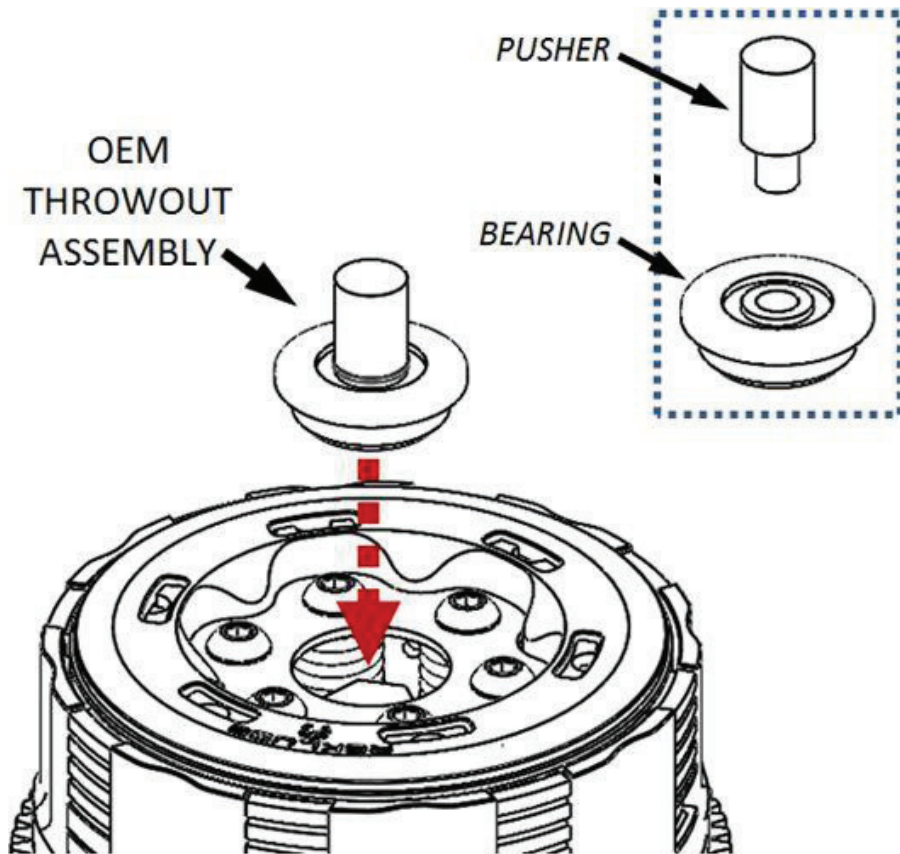

INSTALL THE CLUTCH COVER

1. Reinstall the side case cover gasket or install a new gasket onto to bike.

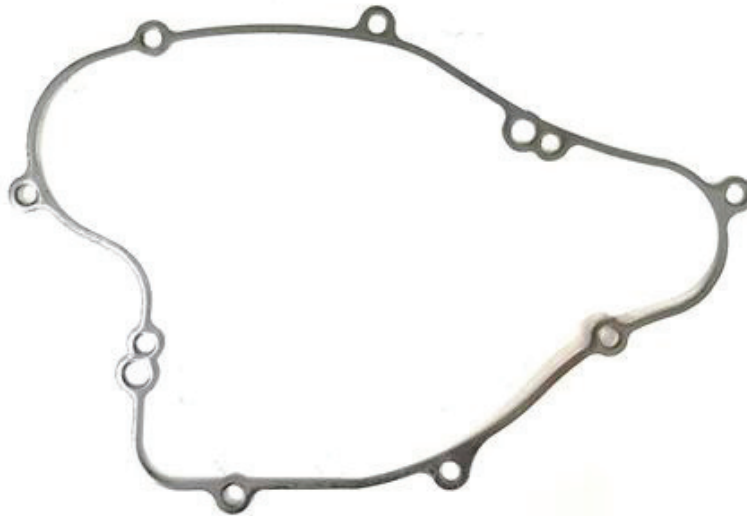

2. Reinstall the side case cover using the OE screws. Be sure to replace the screws in the location they were removed.
3. Install the Rekluse clutch cover by lightly tightening the cover bolts in a star pattern. Tighten bolts in small increments before torqueing the cover bolts to OE specifications.

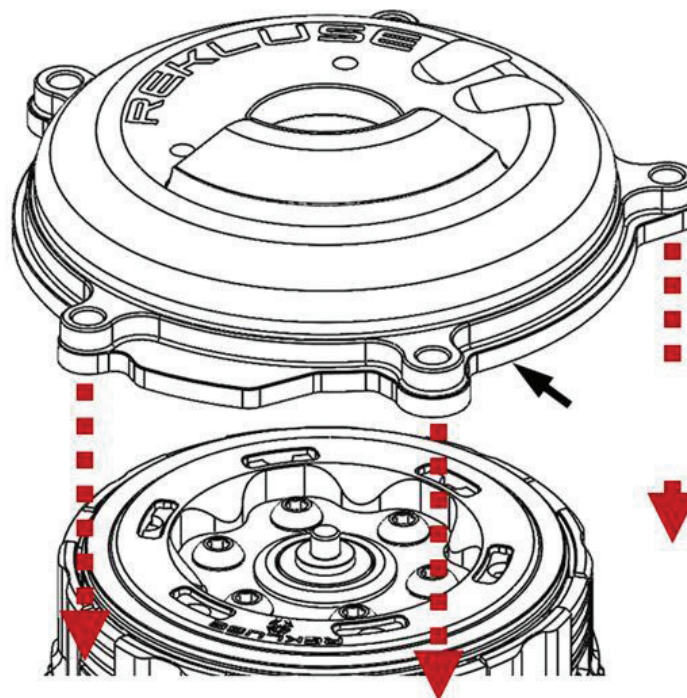

⚠ CAUTION

Failure to install the OE clutch cover bolts back in their proper location can result in damage to your motorcycle.

4. Reinstall the break pedal.
5. Reinstall the kick-start lever.
6. Bleed and install the Rekluse slave cylinder.

Note: *The Rekluse slave cylinder comes preassembled in the kit. If the parts have become separated, assemble them in the following order: Rekluse slave cylinder, O-ring, then the supplied paper gasket.*

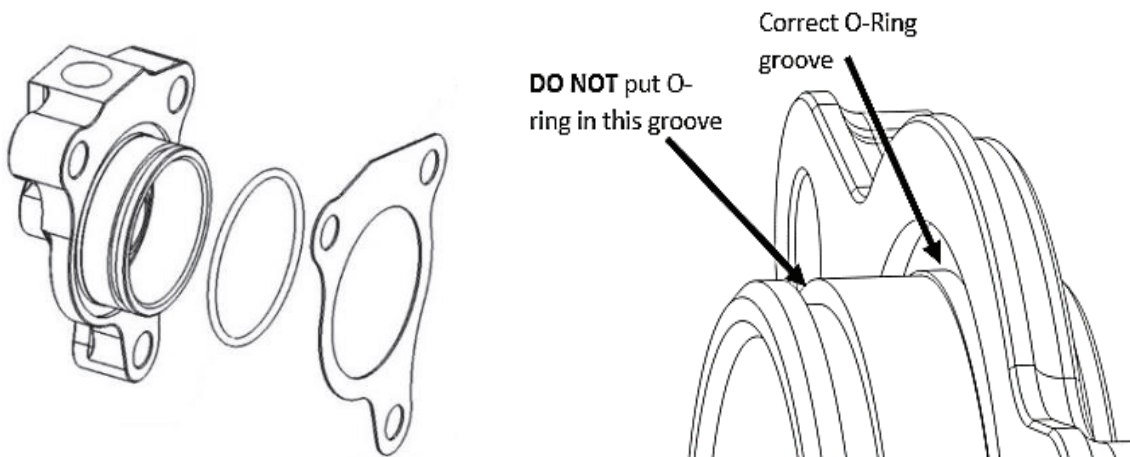

5. Check that the ball bearing is still in place in the center of the piston.
6. Loosely thread the OE clutch fluid line into the port in the Rekluse slave cylinder.

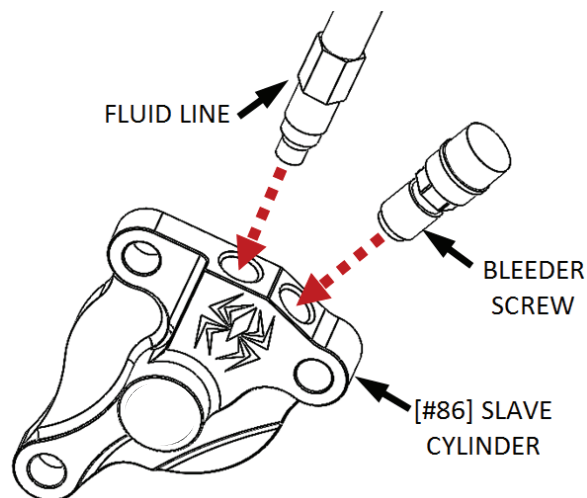

7. Apply Loctite® to the slave cylinder screws.

8. Mount the Rekluse slave cylinder to the cover by lightly threading the two shorter OE bolts on the left side of the spider until finger tight, then thread the longer screw on the right side.

⚠ CAUTION

*The long screw **must** be placed in the location where the slave cylinder housing is thickest (right side of the spider engraving).*

9. Torque the slave cylinder screws evenly to **6 ft-lb (8 N-m)** each.

10. Using a 12 mm open-ended wrench, tighten the clutch line nut.

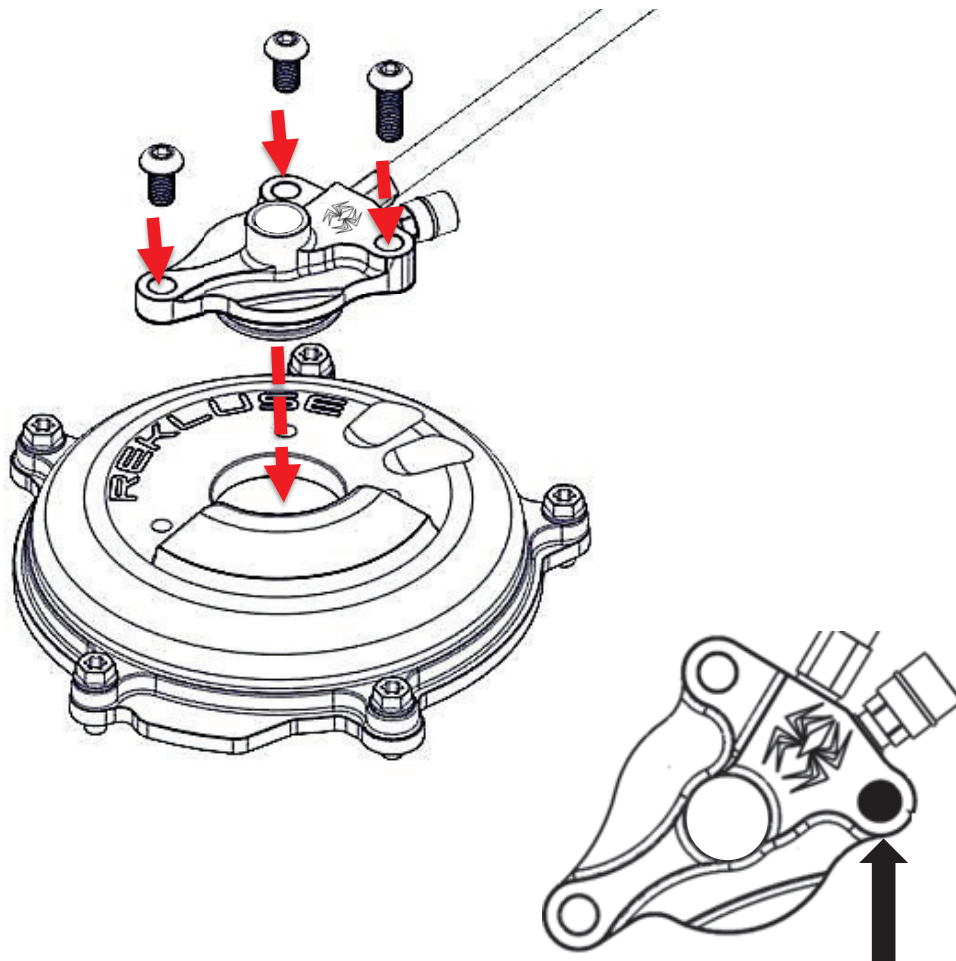

Install long screw to the
right of the spider

BLEED THE CLUTCH LINE

1. Attach one end of the supplied bleed tube to the bleed port on the slave cylinder, then loop the opposite end into a suitable catch bottle.

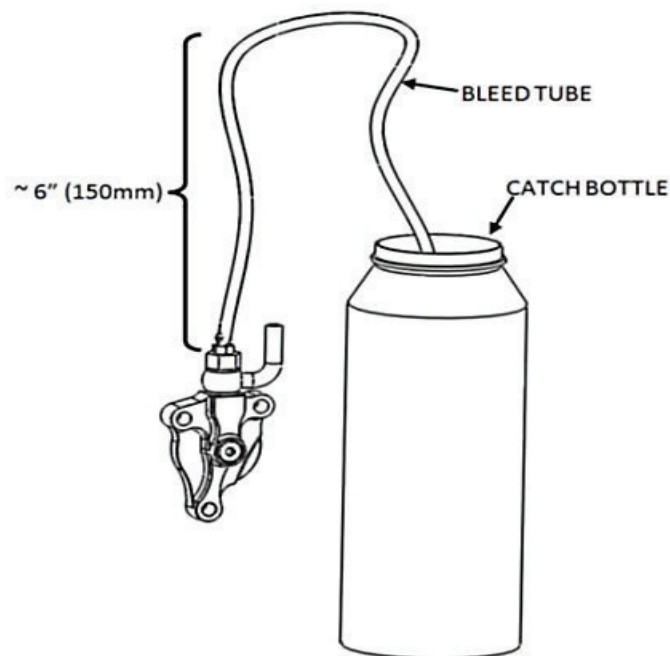

2. On the handlebar, remove the cap and bladder from the clutch master cylinder. Adjust the reservoir so it is level with the ground.

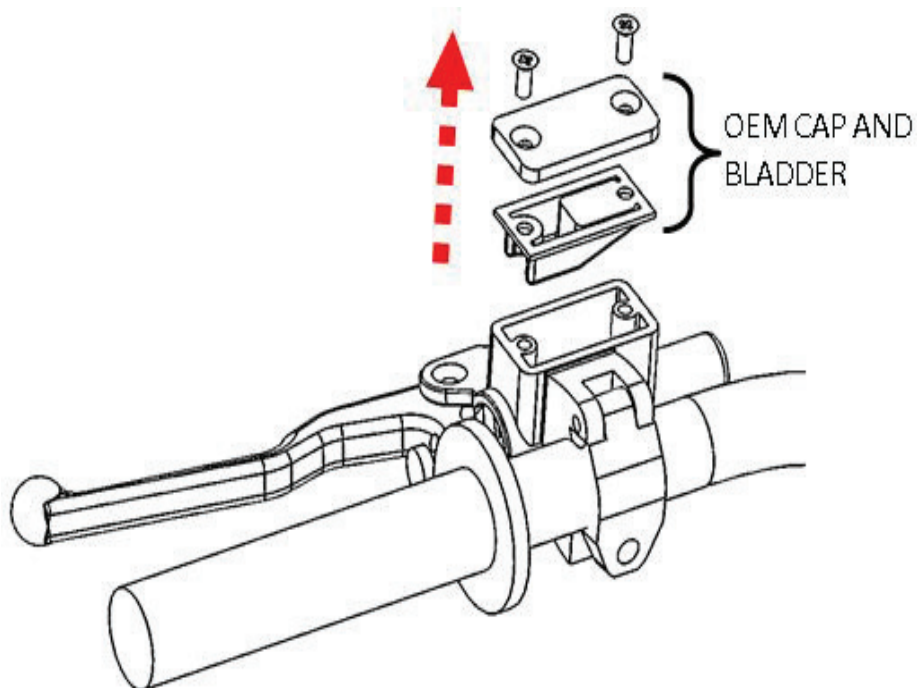

3. Top off the master cylinder with the recommended clutch fluid until it is 75% full.
4. Pump the clutch lever 3 to 5 times, then hold it against the handlebar/grip.

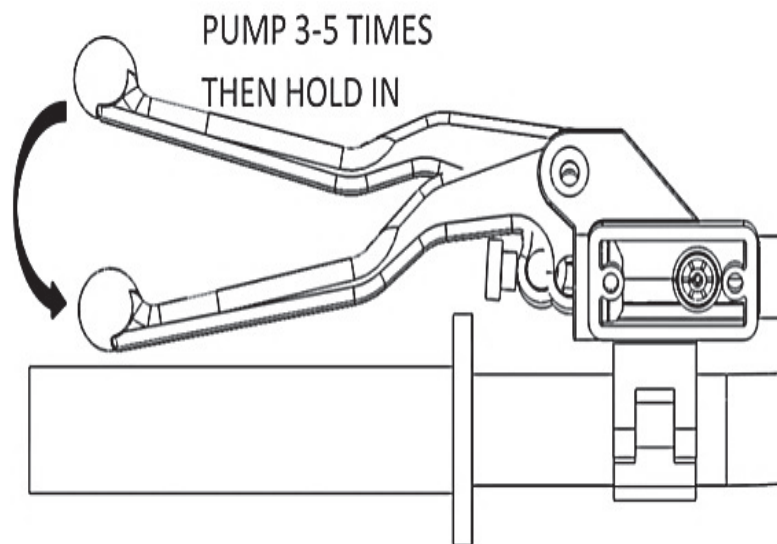

5. While still holding the clutch lever in, use a wrench to open the bleed port. Air and fluid should flow from the bleed tube.

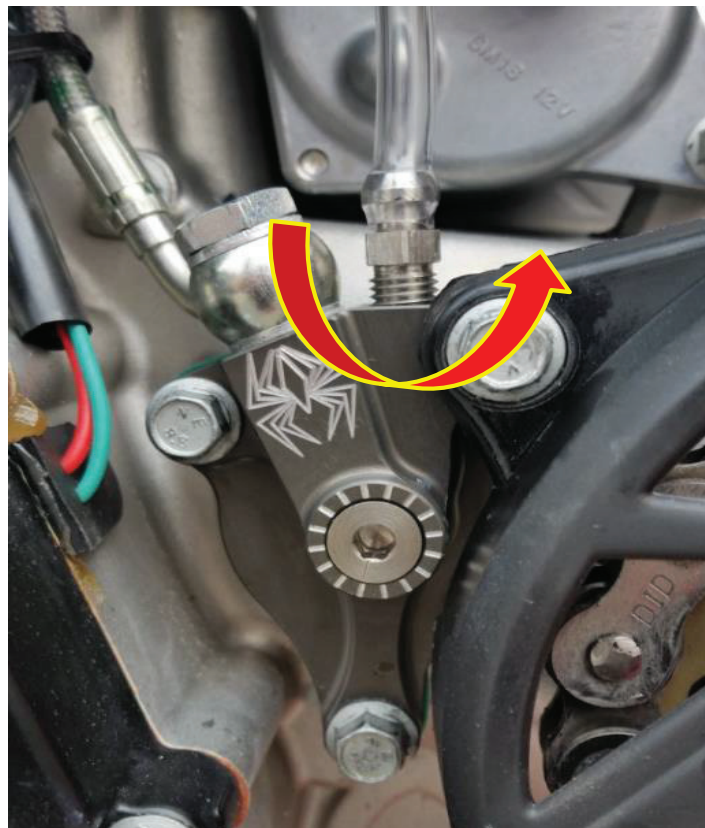

6. Before releasing the clutch lever, tighten the bleed port when the pressure is released from the bleed tube.

7. Slowly release the clutch lever and check the fluid level in the clutch master cylinder. Top off if necessary.

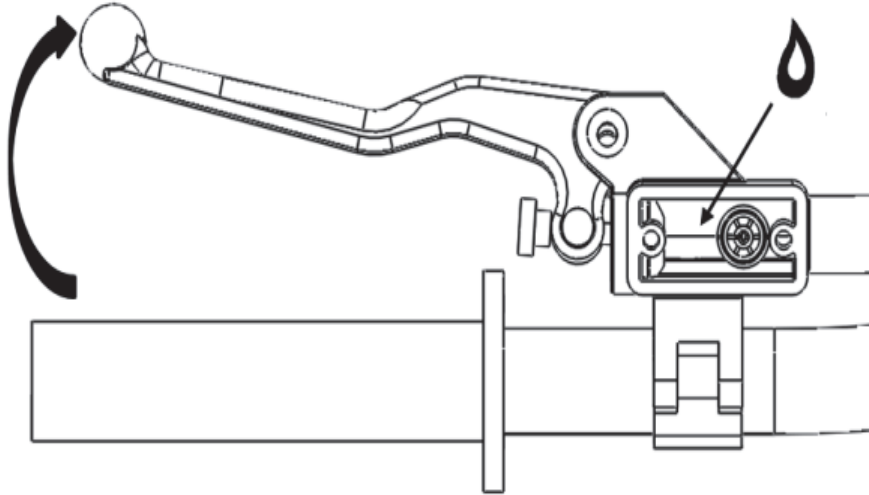

8. Repeat steps 4 - 7 until air no longer comes out of the bleed tube and the clutch feels normal.

9. Check that the clutch master cylinder is 75% full, then replace the cap and bladder.

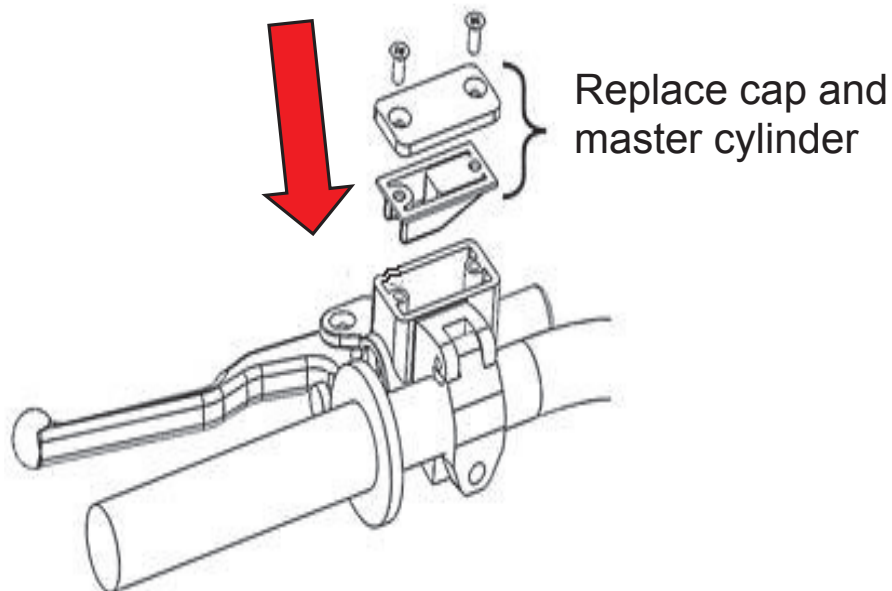

MAINTENANCE

To keep your clutch performing at its best, perform regular maintenance on your bike and clutch.

- Keep up with regular oil changes as per the bike manufacturer's recommendations. Clutch performance and longevity depend on oil quality. Oil recommendations can also be viewed under Tech Tips on our website at www.rekluse.com/support/videos/atv-mc-support-videos.
- Inspect all of your clutch parts for signs of wear or excessive heat, and replace components as necessary. Clutch wear is dependent on the riders use.

Maintenance Protocol	Maintenance Intervals
Inspect all clutch parts for excessive wear or heat. Replace as needed.	Refer to OE service manual
Change oil, inspect and clean oil screen	Refer to OE service manual

- Replace friction disks if the disks are glazed and/or burnt.
- Measuring the clutch pack can help determine if the components need replacing.
- Replace the drive plates if they show signs of excessive heat.

Disk inspection examples

When inspecting the clutch pack, the following pictures can be used as a reference. **These are best viewed in color by viewing this install document on our website at www.rekluse.com/support.**

Drive Plates – If the clutch pack is getting high amounts of heat, purple, blue, or black color can be seen on the drive plate teeth. See pictures below. Not all drive plates look the same and may look different than pictured.



Normal Heat

High Heat
(Blue)

Excessive Heat
(Black)

TROUBLESHOOTING

Performance issues

Excessive heat or clutch slip can cause premature clutch failure. Once extreme temperatures are reached, irreversible damage will occur.

- Inspect all of your clutch parts for signs of wear or excessive heat, and replace components as necessary. Clutch wear is dependent on the riders use.
- Measuring the clutch pack can help determine if the components need replacing. Measure all the frictions and steel drive plates together.

Nominal = **1.195" (30.35 mm)**

Clutch pack Minimum: = **1.170" (29.7 mm)**

Clutch pack Maximum: = **1.220" (31.0 mm)**

Clutch noise

Although it is harmless, some bike models may have “squeal” or “chatter” coming from the clutch at low RPM as it engages. Clutch squeal is caused by the clutch components vibrating as the clutch engages and can become more audible as the clutch gets hot. Adjusting the installed gap will NOT affect clutch squeal or chatter.

For bike models that have clutch squeal or chatter here are some recommendations to reduce or eliminate it:

- Change the oil: For optimal clutch performance Rekluse recommends using fresh, clean oil that **meets JASO-MA** oil rating requirements. Dirty or old oil can make the clutch more likely to squeal or chatter.

NEED ADDITIONAL HELP?

Website

www.rekluse.com/support

Frequently Asked Questions

www.rekluse.com/faq

Support Videos

www.rekluse.com/support/videos

Phone

(208) 426-0659

Technical Support

Contact Technical Support for questions related to product installation, tuning, and performance.

Hours:

Monday thru Friday: 8:00 a.m. - 5:00 p.m.

Mountain Time zone

Email: tech@rekluse.com

Customer Service

Contact Customer Service for additional product information, orders, and returns.

Hours:

Monday thru Friday: 8:00 a.m. - 5:00 p.m.

Mountain Time zone

Email: customerservice@rekluse.com

