



# **INSTALLATION & USER'S GUIDE**

CoreManual  
and  
CoreManual withTorqDrive

for Beta DS Motorcycles

Doc ID: 191-7102122A  
Revision: 120121

# Table of Contents

OVERVIEW .....	2
INSTALLATION TIPS .....	3
TOOLS.....	3
INCLUDED PARTS .....	4
DISASSEMBLE CLUTCH.....	4
INSTALL THE HUB .....	10
INSTALL THE CLUTCH PACK .....	12
Notes for installation.....	12
Pressure Plate Spring Information .....	14
INSTALL THE CLUTCH COVER .....	15
MAINTENANCE.....	16
Disk inspection examples.....	17
TROUBLESHOOTING .....	18
Performance issues.....	18
Clutch noise.....	18
NEED ADDITIONAL HELP?.....	19

## **OVERVIEW**

This install manual is for both CoreManual and CoreManual with TorqDrive clutch kits.

This kit replaces many of the OE (Original Equipment) or “stock” clutch parts.

- The Core Manual kit will replace the OE drive plates with Rekluse steel drive plates.
- The CoreManual with TorqDrive kit will replace all the OE frictions and drive plates with a Rekluse thin friction clutch pack.
- Both kits replace the OE pressure plate springs with high quality Rekluse springs.
- Both kits replace the OE center clutch hub and pressure plate components with Rekluse Core components.

- The OE basket can be re-used if tangs and dampers are in good condition.

## **INSTALLATION TIPS**

- Read the separate included Safety Information document before operating the vehicle with the product installed.
- Read this entire document before performing any steps.
- If you install this product for a customer or another person, instruct them to read the **Safety Information** document and the **Installation and User Guide** before operating the bike with the product.
- Protect eyes and skin – wear safety glasses and work gloves.
- Lay the motorcycle on its left side when replacing the clutch. This makes the clutch work easier and eliminates the need to drain the oil. Catch any fuel that may drain from the bike.
- Use the torque values listed in the instructions. Otherwise, use the torque specifications found in your OE service manual.
- For optimal clutch performance Rekluse recommends using fresh, clean oil that meets JASO-MA oil rating requirements. Rekluse offers Factory Formulated Oil™ developed specifically for Rekluse products. Rekluse Factory Formulated Oil is a perfect complement to any OEM or aftermarket wet clutch. Visit [www.rekluse.com](http://www.rekluse.com) to learn more.

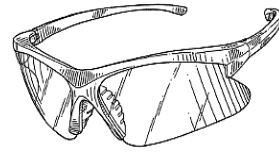

## **TOOLS**

- Fluid Catch Container
- 10 mm socket
- 8 mm socket
- 27mm socket
- Metric Wrench
- Hammer
- Torque Wrench
- Pick
- Channel lock pliers
- 4 mm Hex key
- 5 mm Hex key

# INCLUDED PARTS

The parts included in the kit depend on the bike model. See the **Setup Sheet at the back of this manual** for a list of included parts and illustration.

You can also visit our website at [www.rekluse.com/support](http://www.rekluse.com/support) for a full parts fiche illustration and part numbers.

## DISASSEMBLE CLUTCH

1. If your kit comes with new frictions disks, soak them in new oil for at least 5 minutes. Make sure the friction disks are coated on both sides.
2. If your bike is carbureted, turn the fuel petcock to "OFF."
3. Shift the transmission into 5<sup>th</sup> gear then lay the bike on its left side. Catch any fuel that might drain in a suitable container.

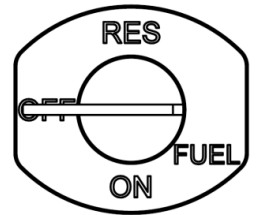
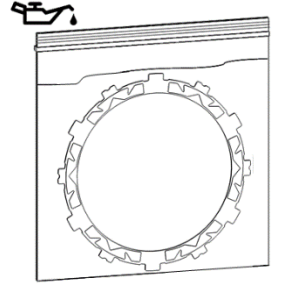

4. Remove the break pedal spring from the clutch cover.



5. Using an 8 mm socket, remove the OE clutch cover. Pay close attention to the length and location of the OE screws so they can be returned to their same location.

**Note:** Clean and set aside the OE cover gasket if OE equipped. The OE cover gasket will be reused.

6. Using an 8mm socket, remove the pressure plate bolts, hold down ring, Belleville Spring and seat, then remove the pressure plate.

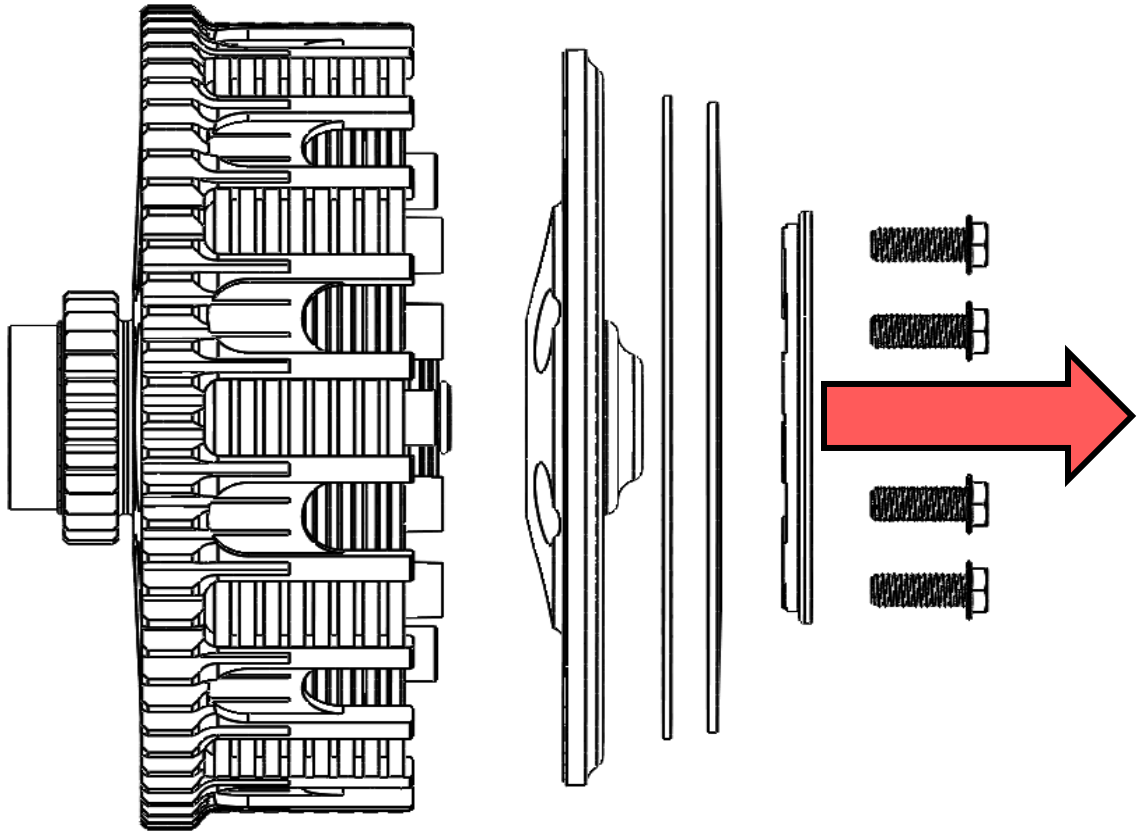

7. Remove the OE clutch pack, then set it aside. Use a pick if necessary to help remove the clutch pack.

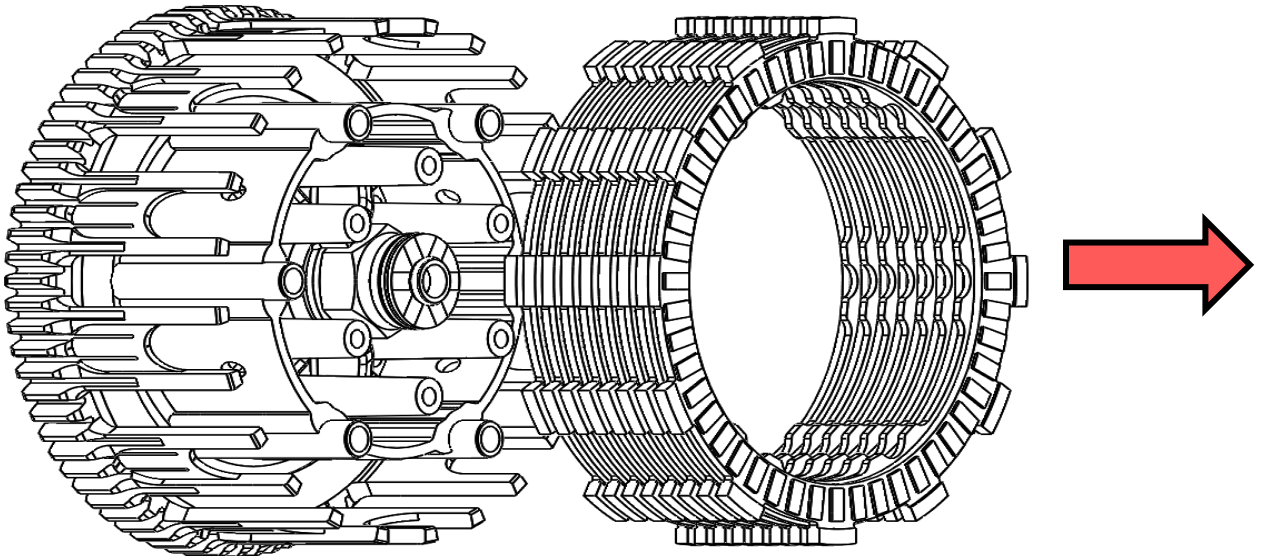

- **CoreManual:**

Separate the friction disks from the drive plates. The friction disks will be reused. Inspect the friction disks per OE specifications and replace if worn.

- **CoreManual TorqDrive:**

Set the clutch pack aside. It will not be reused.



8. Remove the 6 drive pins. Set these aside. The drive pins will be reused.

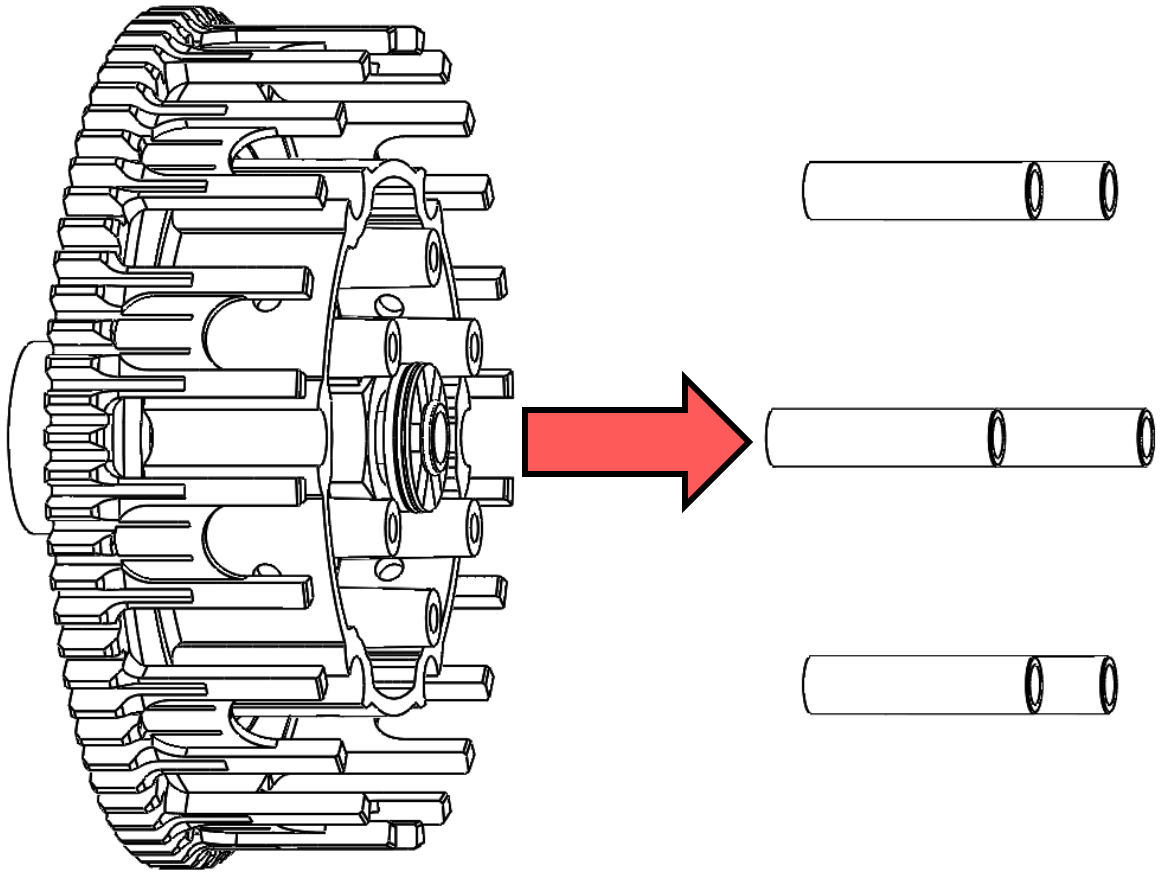

**⚠ CAUTION**

***Be careful the drive pins do not fall into the engine while disassembling.***

9. Inspect the clutch basket for notching or wear. If the basket is notched or worn, replace the basket.

**⚠ WARNING**

**Failure to inspect the basket and replace if necessary could result in death, serious injury, and/or property damage.**

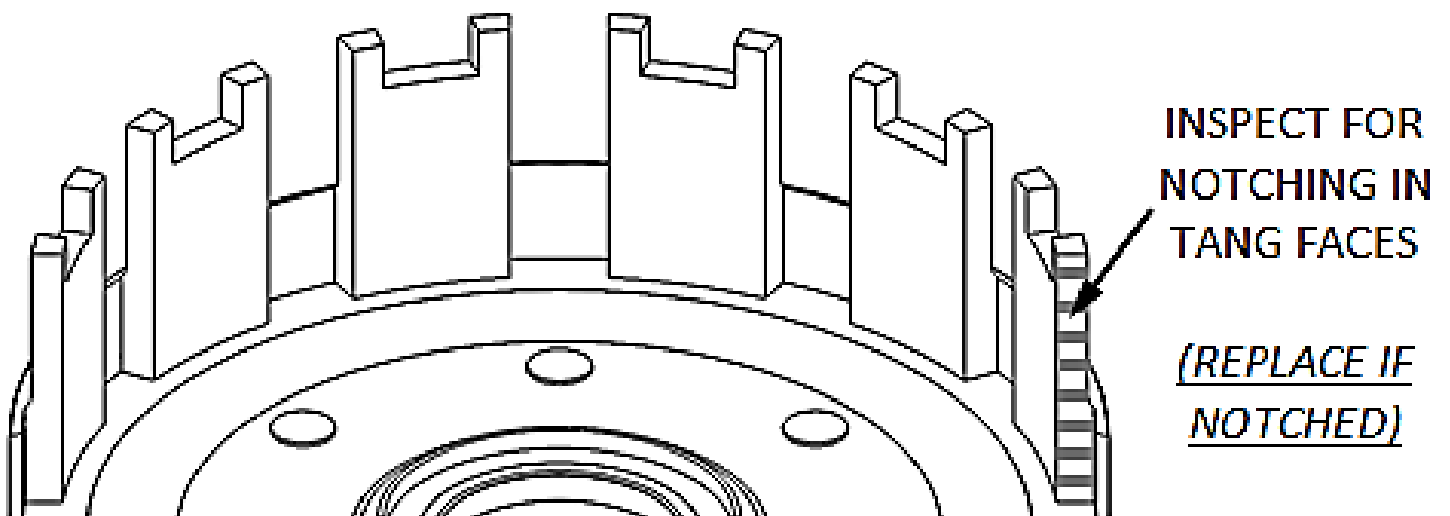

10. Remove the throw-out assembly and set it aside. This assembly will be reused.

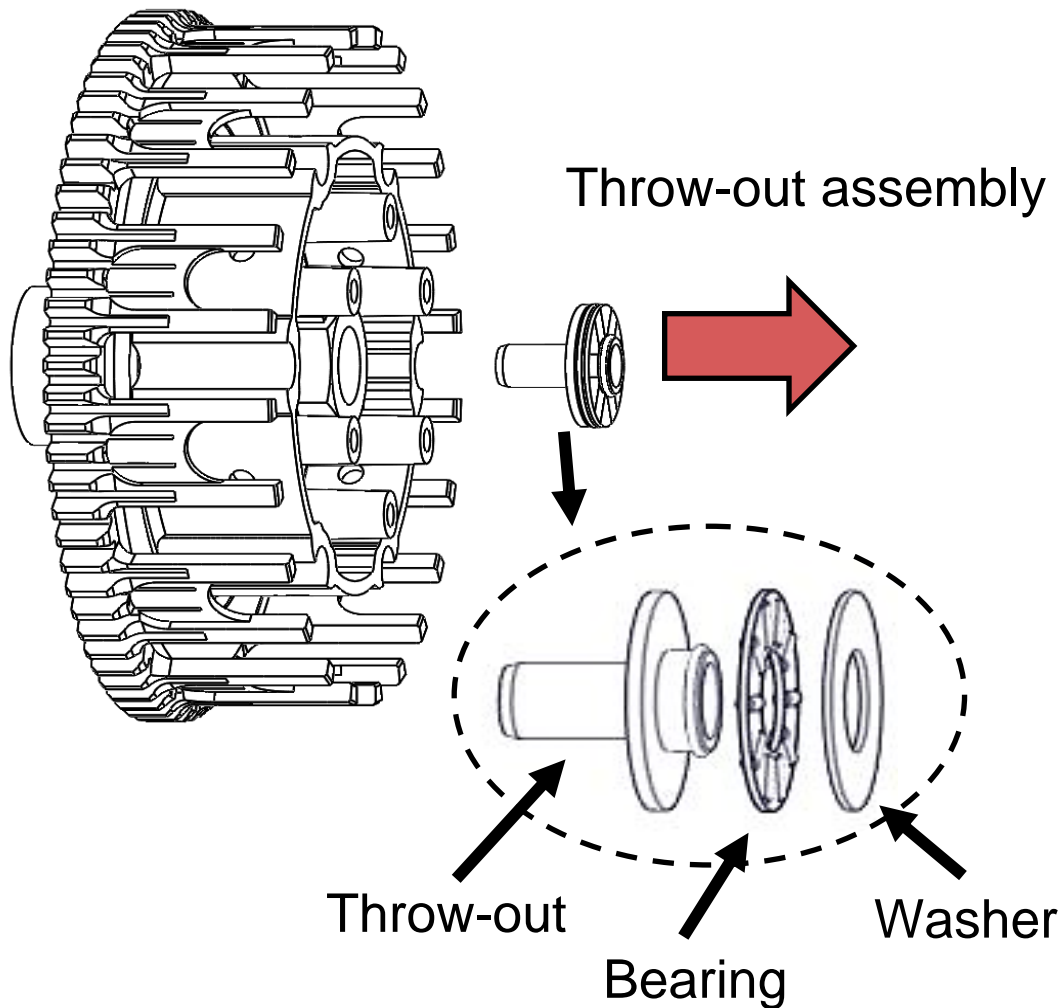

11. Use a hammer and large screwdriver to bend down the edges of the washer tab until it clears the clutch nut.

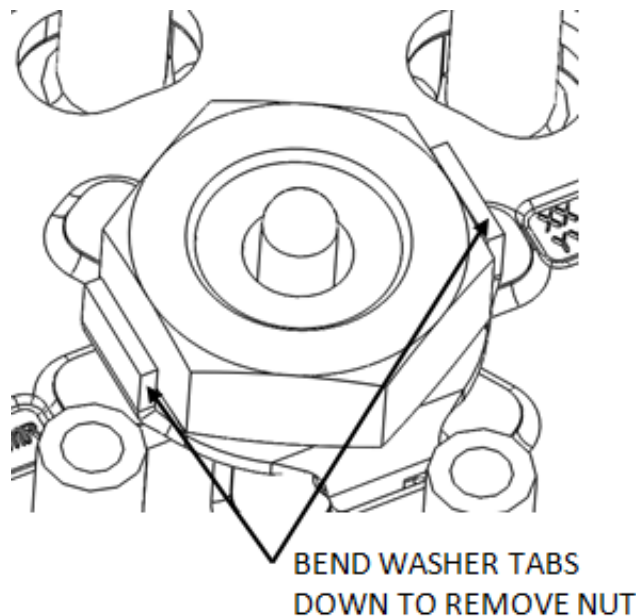

12. Remove the center clutch nut with an impact wrench or breaker bar, and socket. Set aside. The OE clutch nut will be reused.

**Note:** *Placing the bike in the highest gear and holding the rear wheel by applying the rear brake keeps the shaft from rotating when removing the nut.*



13. Remove the washer located under the center clutch nut and the center hub from the clutch basket while leaving the thrust washer underneath on the main shaft. The OE washer will be replaced with a Rekluse tab lock washer.

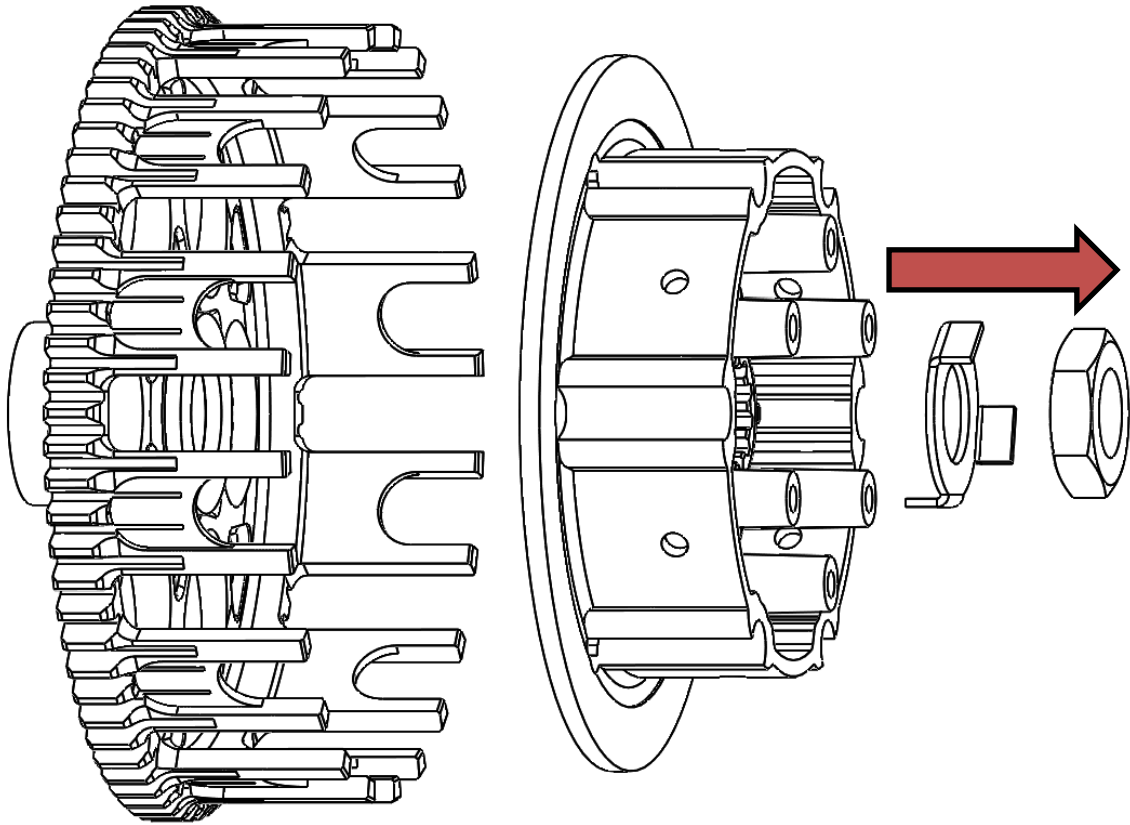

**Note:** Check that the OE thrust washer is still on the main shaft and not stuck to the bottom of the center hub assembly. The thrust washer must be installed or clutch performance issues will result.

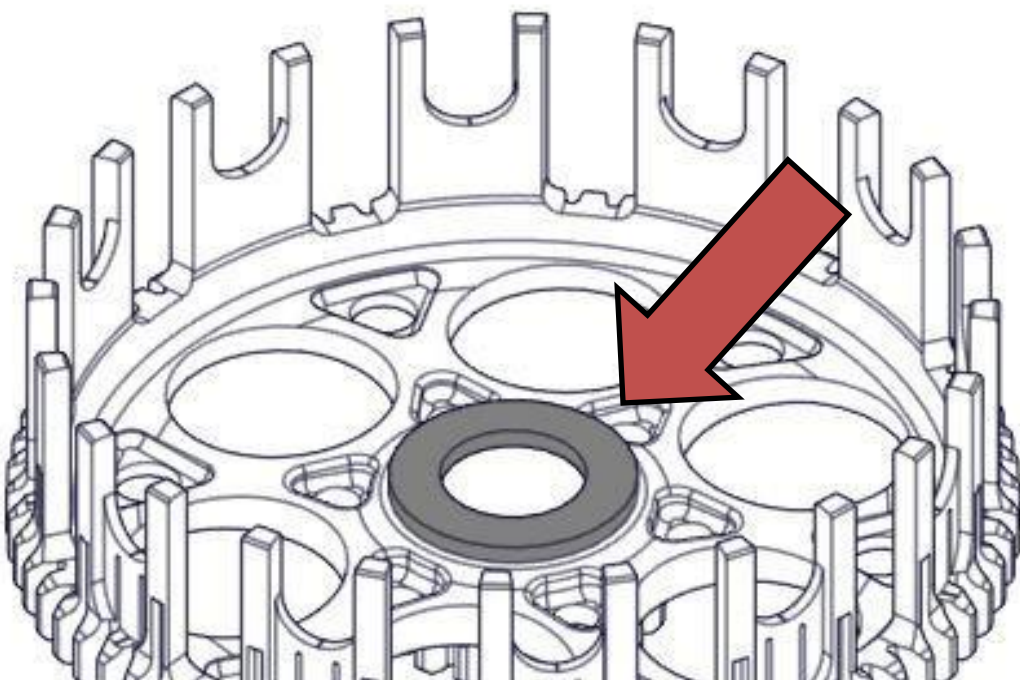

# **INSTALL THE HUB**

1. Install the new Rekluse center hub into the clutch basket.

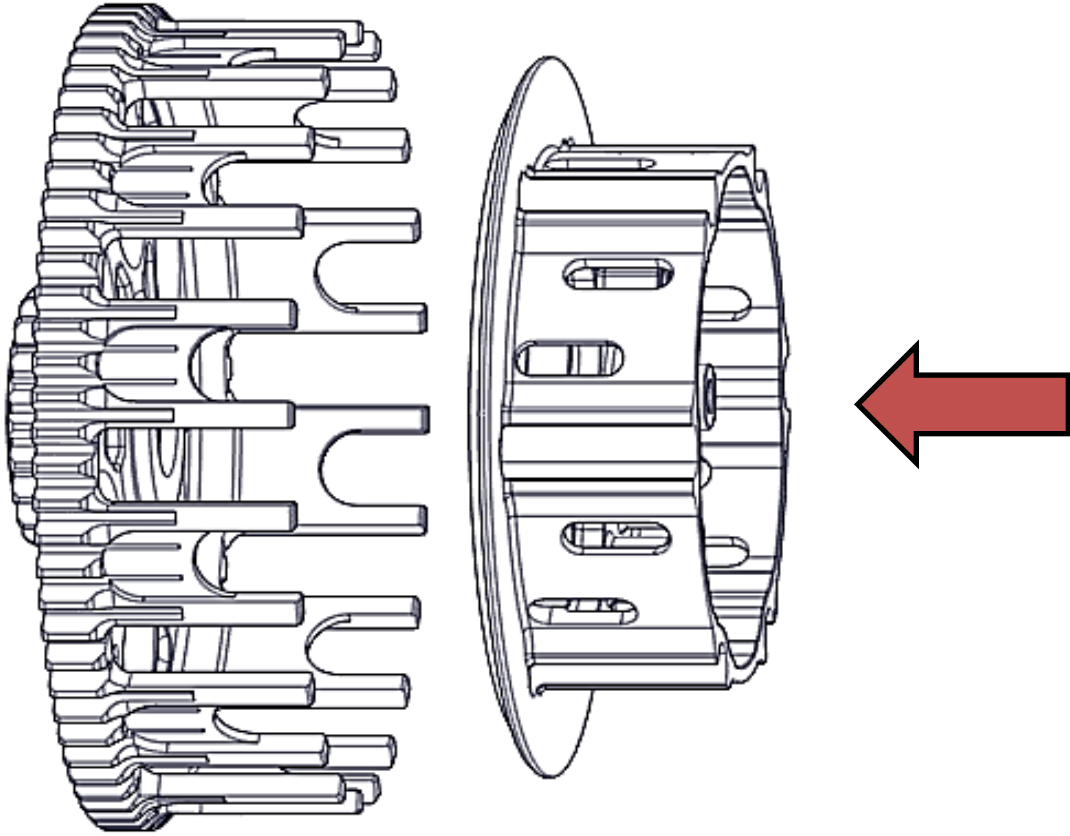

2. Install the new Rekluse tab washer with the bent tabs facing down, aligning with the holes in the hub.



3. Reinstall the OE clutch nut.

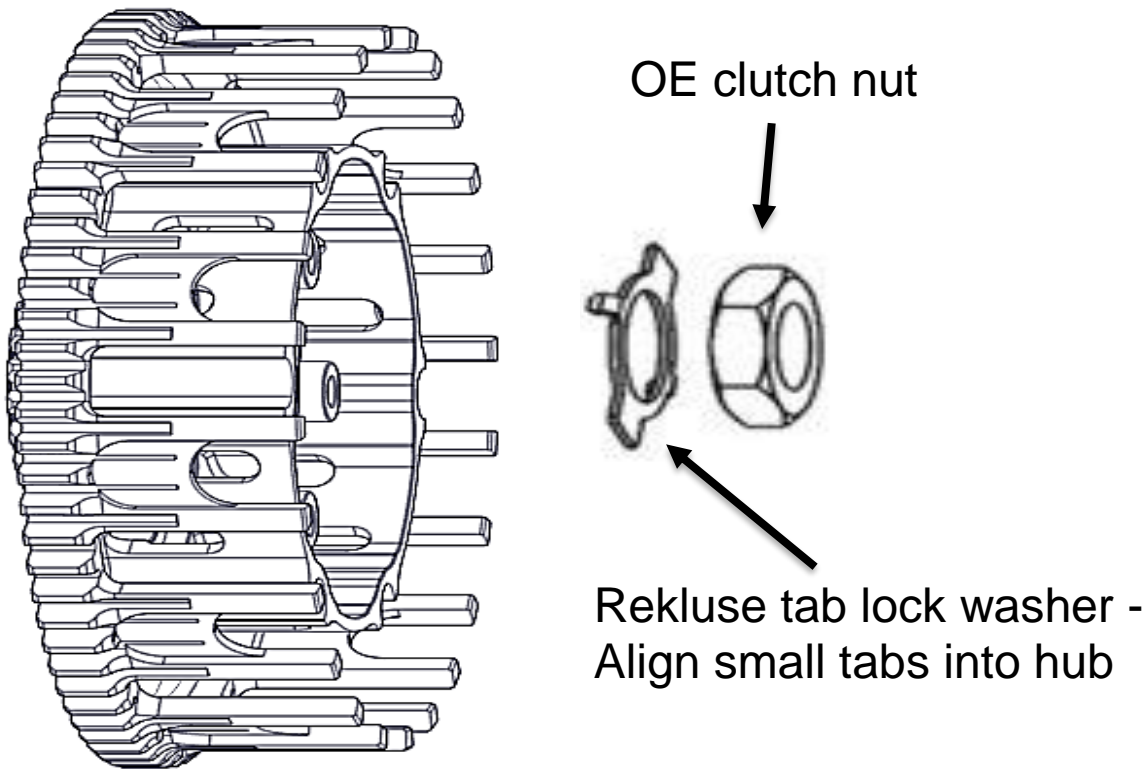

4. Using the socket and torque wrench, torque the center clutch nut to **50 ft-lb (68 N-m)**.

**Note:** *Placing the bike in the highest gear and holding the rear wheel by applying the rear brake keeps the shaft from rotating when tightening the nut.*

5. Using the channel-lock pliers, bend up **both** tabs of the tab washer tightly around the nut. The tabs can be bent on the straight sides or around the corners.

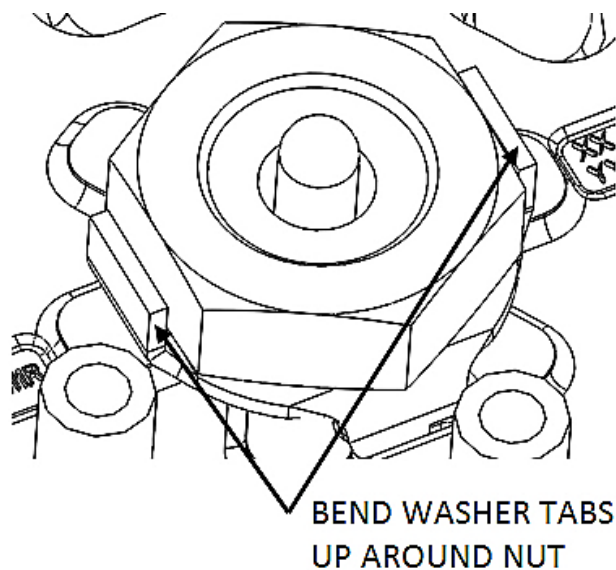

# INSTALL THE CLUTCH PACK

## Notes for installation

- *Some friction disks are marked with a small colored dot. This mark is used for processing and can be ignored.*
- *OE baskets have “half slots” at the top of the basket tangs. Rekluse products require that all friction disks’ tabs are installed into the MAIN (deeper) basket slots. Do not use the “half-slots.”*

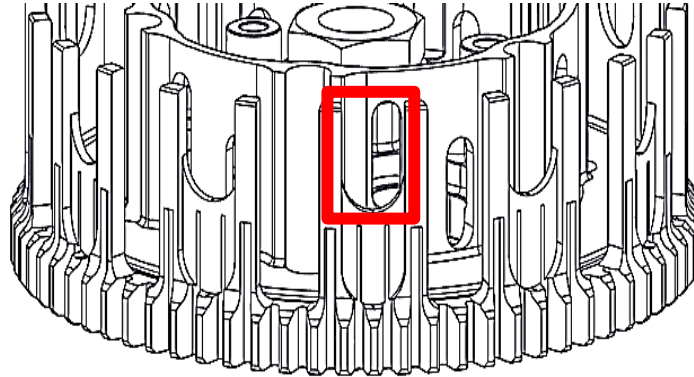

1. Install the 6 OE drive pins onto the Rekluse center hub, in the cut pin channels.

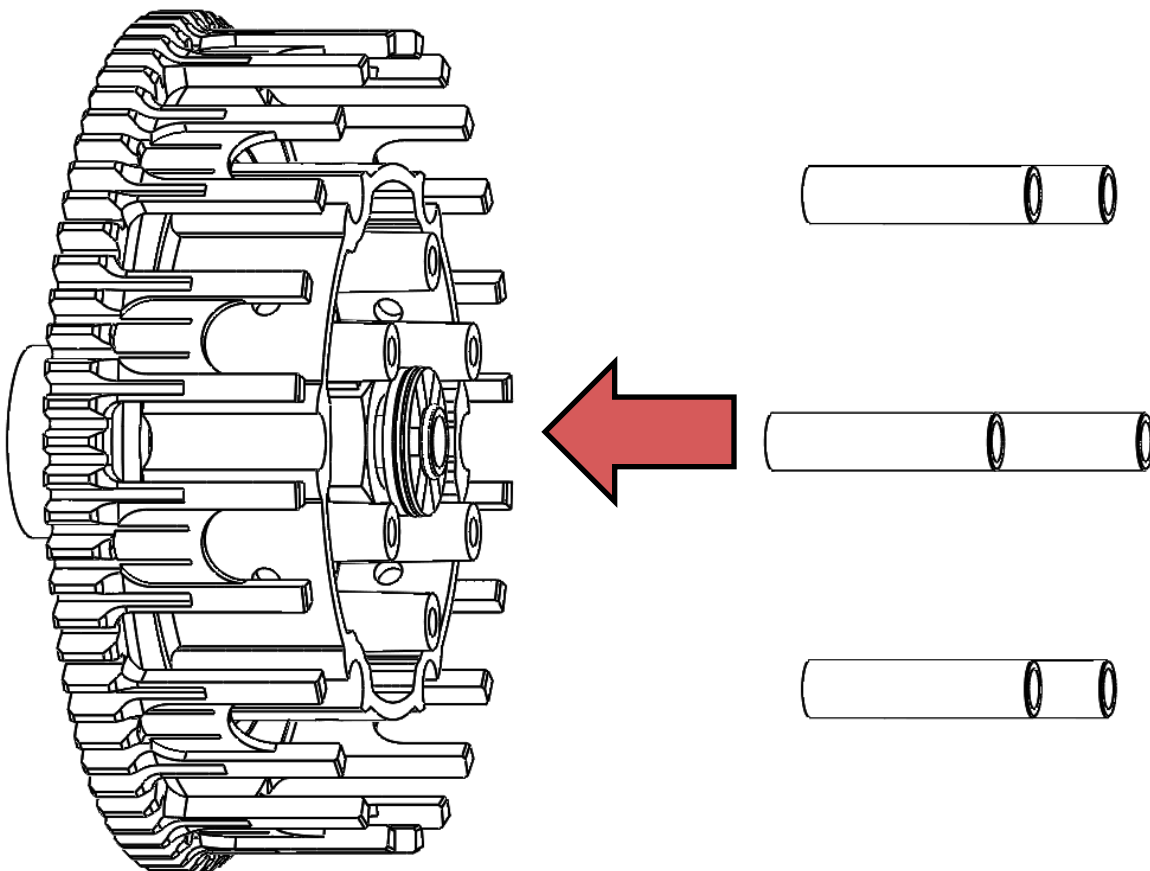

2. The clutch pack is installed based on the type of clutch kit. Install the clutch pack one plate at a time according to the order in **Setup Sheet** at the back of the manual.



3. Reinstall the OE throw-out assembly.

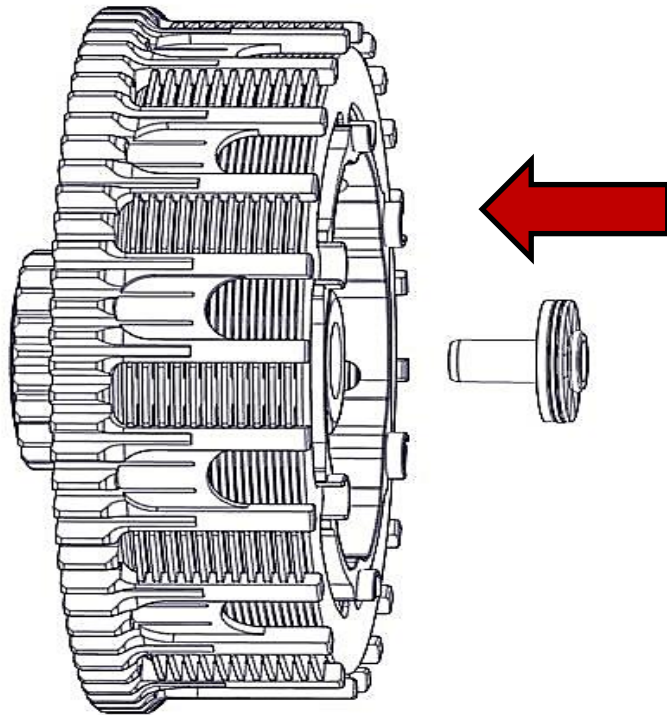

4. Install the pressure plate onto the clutch pack.

5. Install the Rekluse pressure plate, pressure plate springs, screw sleeves, and pressure plate bolts.

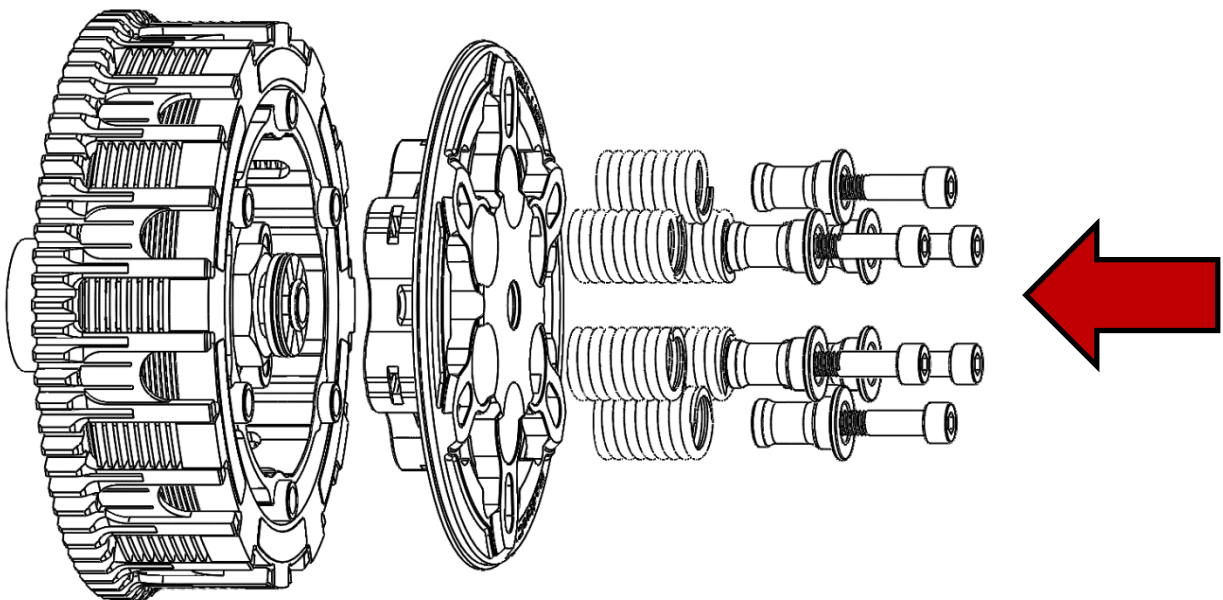

**⚠ CAUTION**

***Do not reuse the OE springs or bolts. They are not compatible with the Rekluse core parts.***

**Note:** *Be sure to alternate springs if you are using two different color springs to keep even pressure on the clutch. See following section for pressure plate spring options.*

6. Using a torque wrench, tighten the pressure plate bolts to 9 ft-lbs (12 N-m).

# Pressure Plate Spring Information

Do not use higher force pressure plate springs than those included in the kit. Charts are representative. Differences in clamping force and torque capacity will vary by model.

**CoreManual:** This kit ships with 6 red springs, which is the recommended setting. Alternative springs can be purchased separately from Rekluse.

**CoreManual TorqDrive:** There are three spring options in your kit.

- Silver springs provide torque transfer similar to the stock clutch, but with a very light clutch lever.
- Gold springs will give the feel of a smoother clutch with a clutch lever pull lighter than stock.
- Red springs will yield a more aggressive clutch with clutch pull similar to stock.
- Using three of each spring (3 silver / 3 red) will result in an in-between setup. Be sure to alternate springs when using a 3 and 3 combo of springs to keep even pressure on the clutch.
- Rekluse recommends installing 3 gold and 3 red springs for best performance and clutch life.

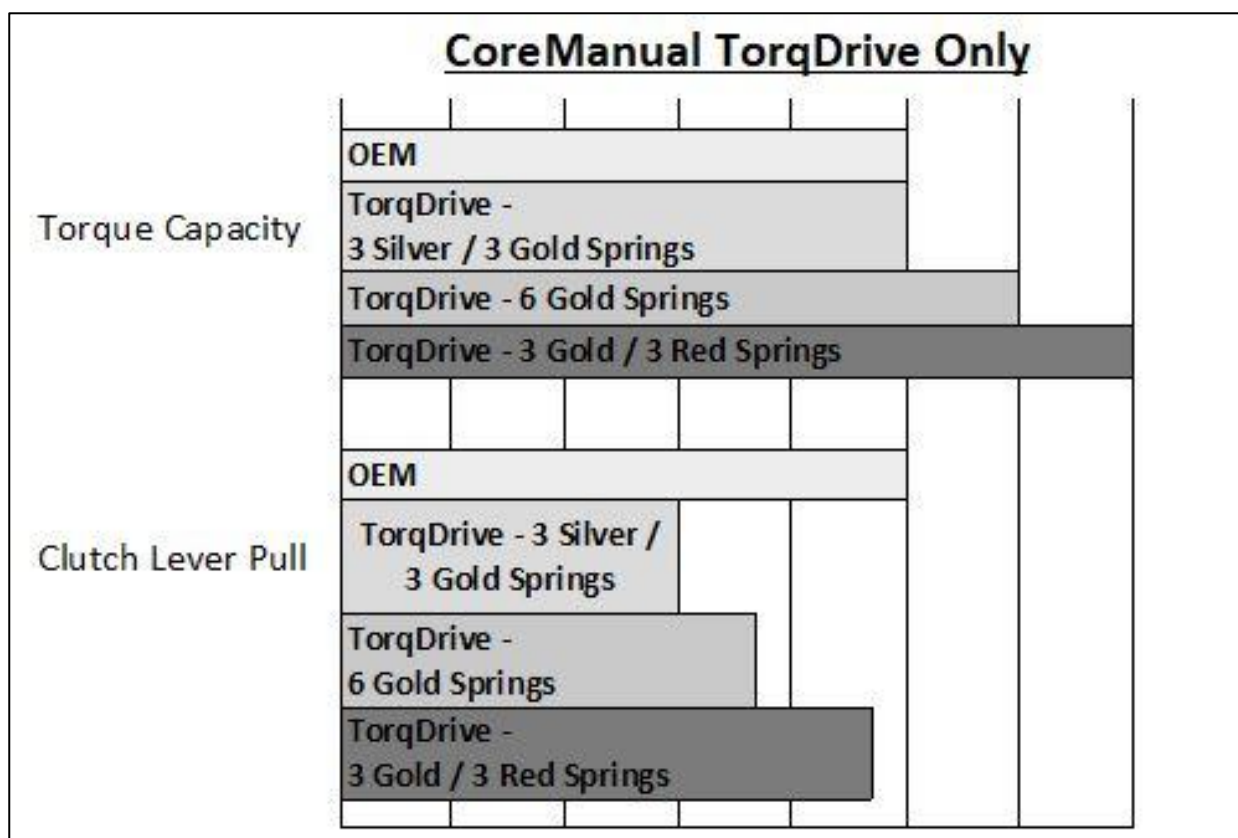



# **INSTALL THE CLUTCH COVER**

Install the clutch cover according to the type of clutch kit.

- **CoreManual kit:**

- a. Check to make sure that the OE gasket is installed on the OE cover.
- b. Reinstall the OE cover onto the bike.

- **CoreManual TorqDrive kit:**

- a. Install the OE cover gasket, if equipped, onto the Rekluse clutch cover.
- b. Install the Rekluse cover onto the bike.

## **Both kits:**

1. Reinstall the OE bolts, then lightly tighten the cover bolts in small increments in a star pattern. Be sure to return the bolts in the same location they were removed.



***Failure to install the OE clutch cover bolts back in their proper location can result in damage to your motorcycle.***

2. Torque the cover bolts to 9 ft-lbs (12 N-m).
3. Reinstall the break pedal spring onto the clutch cover.

# MAINTENANCE

To keep your clutch performing at its best, perform regular maintenance on your bike and clutch.

- Keep up with regular oil changes as per the bike manufacturer's recommendations. Clutch performance and longevity depend on oil quality. Oil recommendations can also be viewed under Tech Tips on our website at [www.rekluse.com/support/videos/atv-mc-support-videos](http://www.rekluse.com/support/videos/atv-mc-support-videos).
- Inspect all of your clutch parts for signs of wear or excessive heat, and replace components as necessary. Clutch wear is dependent on the riders use.

<b>Maintenance Protocol</b>	<b>Maintenance Intervals</b>
Inspect all clutch parts for excessive wear or heat. Replace as needed.	Refer to OE service manual
Change oil, inspect and clean oil screens	Refer to OE service manual

- Inspect the dampers, and replace them if you feel any movement between the two hubs. Refer to the section on inspecting the dampers for more information.
- Replace friction disks if the disks are glazed and/or burnt.
- Measuring the clutch pack can help determine if the components need replacing.
- Repeat the break-in procedure anytime you replace frictions disks. Always soak friction disks in oil for at least 5 minutes before installing.
- Replace the drive plates if they show signs of excessive heat.

# Disk inspection examples

When inspecting the clutch pack, the following pictures can be used as a reference. **These are best viewed in color by viewing this install document on our website at [www.rekluse.com/support](http://www.rekluse.com/support).**

**Drive Plates** – If the clutch pack is getting high amounts of heat, purple, blue, or black color can be seen on the drive plate teeth. See pictures below. Not all drive plates look the same and may look different than pictured.



Normal Heat

High Heat  
(Blue)

Excessive Heat  
(Black)

**Friction Disks** – Due to the dark color of the friction material, the friction disks will appear almost black as soon as they are put in oil. During inspection, look for glazing of the friction material. Glazing will appear shiny and feel like glass, even after oil is cleaned from the friction disk. Not all friction disks look the same and may look different than pictured.



Normal  
Friction



Glazed  
Friction

# **TROUBLESHOOTING**

## **Performance issues**

If the clutch drags, the clutch disks might be worn. Excessive heat or clutch slip can cause premature clutch failure as well. Once extreme temperatures are reached, irreversible damage will occur.

- Inspect all of your clutch parts for signs of wear or excessive heat, and replace components as necessary. Clutch wear is dependent on the riders use.
- Measuring the clutch pack can help determine if the components need replacing.

## **Clutch noise**

Although it is harmless, some bike models may have “squeal” or “chatter” coming from the clutch at low RPM as it engages. Clutch squeal is caused by the clutch components vibrating as the clutch engages and can become more audible as the clutch gets hot. Adjusting the installed gap will NOT affect clutch squeal or chatter.

For bike models that have clutch squeal or chatter here are some recommendations to reduce or eliminate it:

- Change the oil: For optimal clutch performance Rekluse recommends using fresh, clean oil that meets JASO-MA oil rating requirements. Dirty or old oil can make the clutch more likely to squeal or chatter.

# **NEED ADDITIONAL HELP?**

## **Website**

[www.rekluse.com/support](http://www.rekluse.com/support)

## **Frequently asked questions**

[www.rekluse.com/faq](http://www.rekluse.com/faq)

## **Support Videos**

[www.rekluse.com/support/videos](http://www.rekluse.com/support/videos)

## **Phone**

(208) 426-0659

## **Technical Support**

Contact Technical Support for questions related to product installation, tuning, and performance.

### **Hours:**

Monday thru Friday: 8:00 a.m. - 5:00 p.m.

Mountain Time zone

Email: [tech@rekluse.com](mailto:tech@rekluse.com)

## **Customer Service**

Contact Customer Service for additional product information, orders, and returns.

### **Hours:**

Monday thru Friday: 8:00 a.m. - 5:00 p.m.

Mountain Time zone

Email: [customerservice@rekluse.com](mailto:customerservice@rekluse.com)



# SETUP SHEET 198-7002122

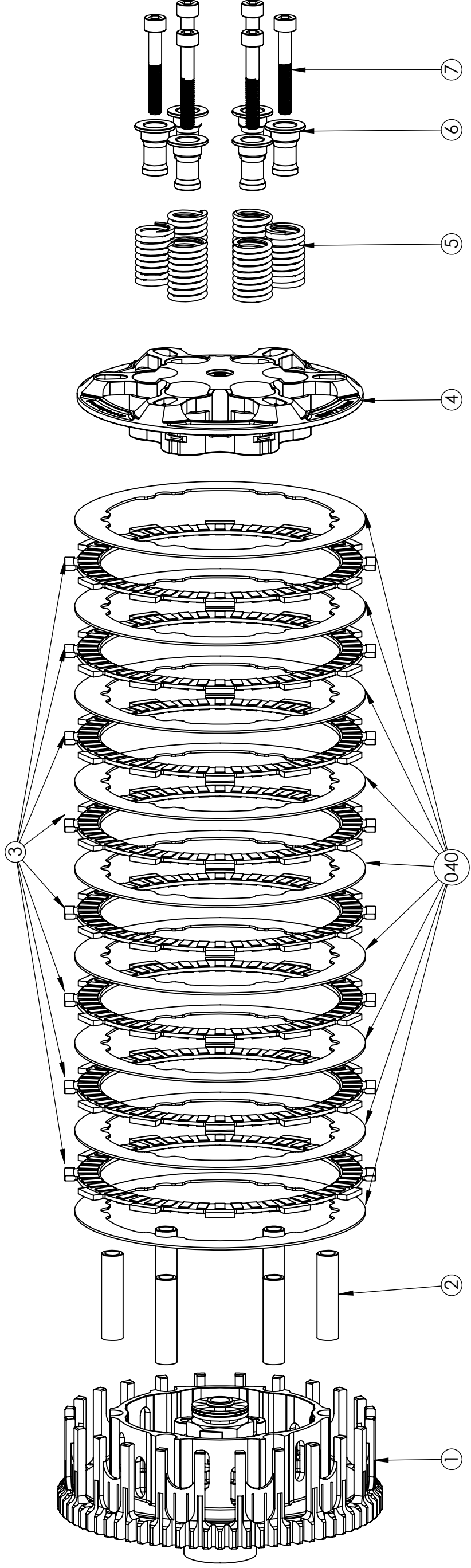

## CLUTCH PACK THICKNESS

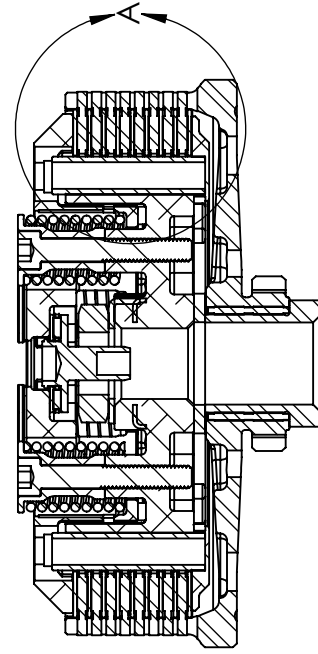
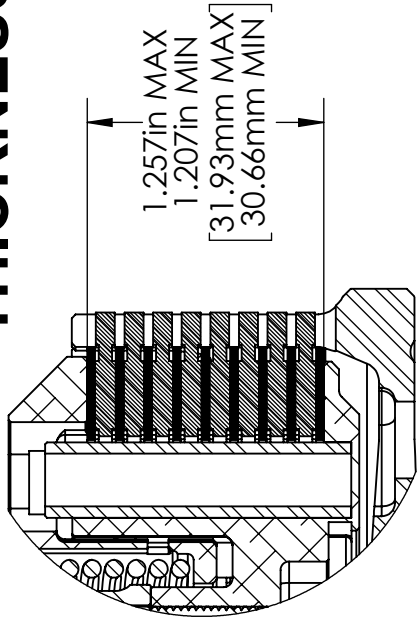

DETAIL A  
SCALE 1 : 1

## COMPONENTS

ITEM NO.	DESCRIPTION	QTY.
1	OE BASKET	1
2	OE DRIVE PIN	6
3	OE FRICTION DISK	8
4	REKLUSE PRESSURE PLATE	1
5	REKLUSE PRESSURE PLATE SPRINGS	6
6	REKLUSE SCREW SLEEVE	6
7	PRESSURE PLATE SCREW	6
040	DRIVE PLATE 0.040" (1mm)	9