



INSTALLATION & USER'S GUIDE

RadiusX Clutch
for Pull-Style, Cable Actuated Street Bikes

Doc ID: 191-6313A
Revision: 080219

TABLE OF CONTENTS

OVERVIEW.....	3
INSTALLATION TIPS.....	3
TOOLS NEEDED	5
INCLUDED PARTS	5
DISASSEMBLE THE CLUTCH.....	5
CLUTCH PACK INSTALLATION	8
Notes for clutch pack installation	8
Install Clutch Pack.....	11
CLUTCH COVER INSTALLATION.....	13
SET THE INSTALLED GAP	16
CHECK FREE PLAY GAIN.....	16
Learn how to check Free Play Gain	16
Two Ways to Check for Free Play Gain.....	17
The Rubber Band Method.....	17
The Hand Method	19
ADJUST THE INSTALLED GAP	19
BREAK-IN THE NEW CLUTCH.....	21
CLUTCH LEVER OPTIMIZATION.....	23
Optimization with Rekluse Adjustable Reach Lever	23
MAINTENANCE	24
Clutch wear.....	24
Clutch parts	24
Basket.....	25
Disk inspection examples.....	25
NEED ADDITIONAL HELP?.....	26

OVERVIEW

This kit replaces many of the OE (Original Equipment) or “stock” clutch parts. These parts are designed specifically for your motorcycle to ensure optimal performance. The following is a summary of what is replaced:

- This kit will replace all the OE friction disks and drive plates with a Rekluse thin friction EXP clutch pack.
- The OE pressure plate springs are replaced with high quality Rekluse springs.

INSTALLATION TIPS

- Read the separate included **Safety Information** document before operating the vehicle with the product installed.
- Read this entire document before performing any steps.
- If you install this product for a customer or another person, instruct them to read the **Safety Information** document and the **Installation and User Guide** before operating the bike with the product.
- Protect eyes and skin – wear safety glasses and work gloves.
- Drain the oil before removing the clutch cover. If possible, you can also lay the bike on its side to avoid draining oil.
- Use the torque specifications found in your OE service manual.
- **Oil:** For optimal clutch performance Rekluse recommends using fresh, clean oil that **meets JASO-MA** oil rating requirements. Rekluse offers Factory Formulated Oil™ developed specifically for Rekluse products.
- **This clutch pack is not legal to race with in the AMA Limited or Stock class.**



TOOLS NEEDED

			
10 mm socket	8 mm socket	Metric Wrench	Torque Wrench
			
Pick	Fluid Catch Container	4 mm Hex key	

INCLUDED PARTS

The parts included in the kit depend on the bike model. See the **Setup Sheet** at the back of this manual for a list of included parts and illustration.

You can also visit our website at www.rekluse.com/support for a full parts fiche illustration and part numbers.

DISASSEMBLE THE CLUTCH

1. Soak the Rekluse friction disks in new oil for at least 5 minutes. Make sure the friction disks are coated on both sides.

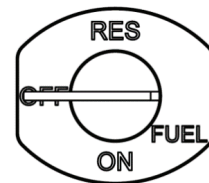
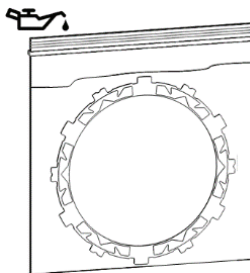

2. If applicable, turn the fuel petcock to “OFF.”
3. Drain the oil or lean the bike on its side.
4. ***Before removing the clutch cover***, be sure to note the position of the clutch actuator arm as shown below. This is critical for adjustment. It may look slightly different than the image shown below; note the position of the actuator arm as it appears on your particular bike.



5. Remove the clutch cable from the actuator arm.
6. Remove the OE clutch cover. Set aside. It will be reused.

7. Remove the OE pressure plate bolts, springs, pressure plate, and throw-out.

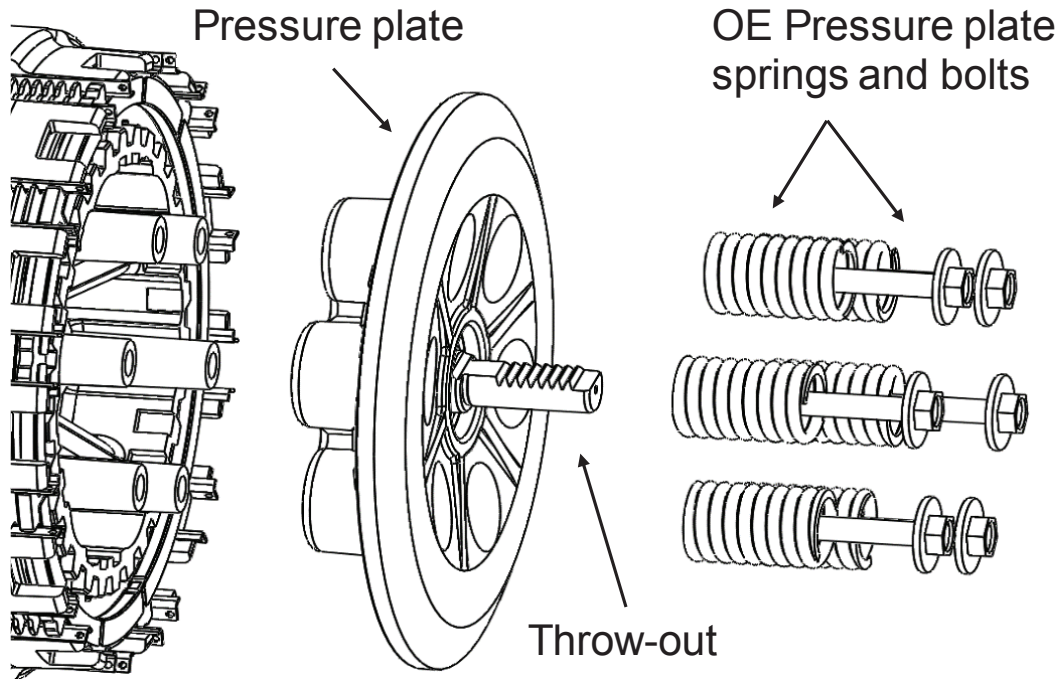

Note: *The throw-out pictured may not represent the throw-out in all models.*

8. Remove the clutch pack.

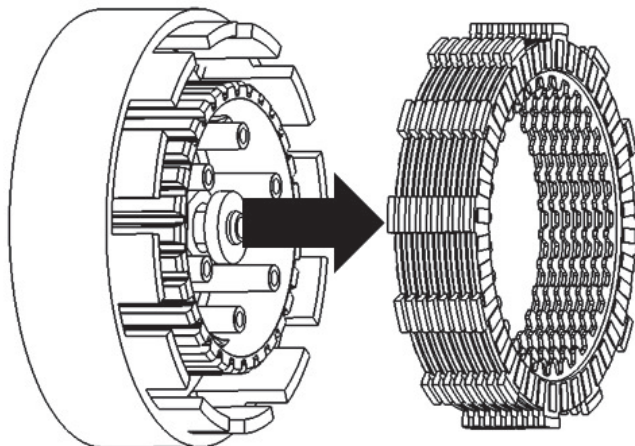

Note: Some models have a clutch boss spring located in the bottom of the OE friction pack. This consists of a spring, seat and narrow friction. If your bike is equipped with these parts, remove them and set the spring aside. Only some bikes will reuse the spring. Refer to the Setup Sheet for installation.

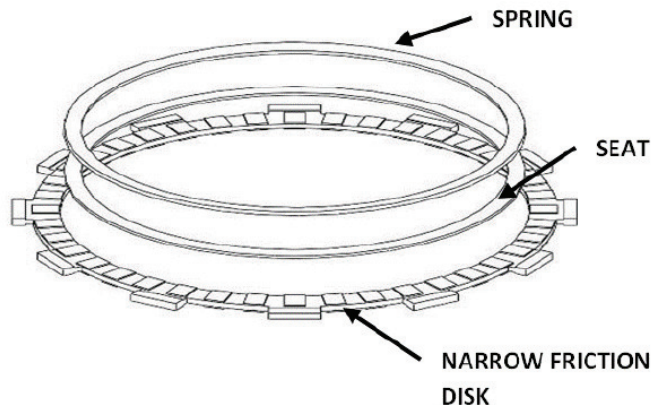

CLUTCH PACK INSTALLATION

Notes for clutch pack installation

- *Some friction disks are marked with a small colored dot. This mark is used for processing and can be ignored.*

- Some OE baskets have “half slots” at the top of the basket tangs. Rekluse products require the entire clutch pack be installed into the MAIN (deeper) basket slots. Do not use the “half slots.” See the following picture for reference.

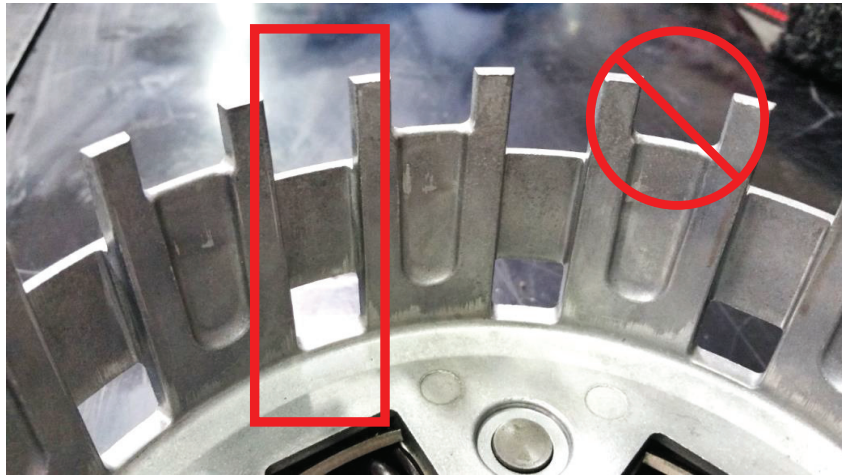

- Inspect the clutch basket for damper and/or spring play. Inspect the clutch basket for notching. Do not install sleeves or use product with a notched basket. Notched basket tang faces can cause the sleeves to break. Do not use baskets that have been filed, machined, or modified on the tangs. Replace basket if necessary.

⚠ WARNING

Failure to inspect the basket and replace if necessary could result in death, serious injury, and/or property damage.

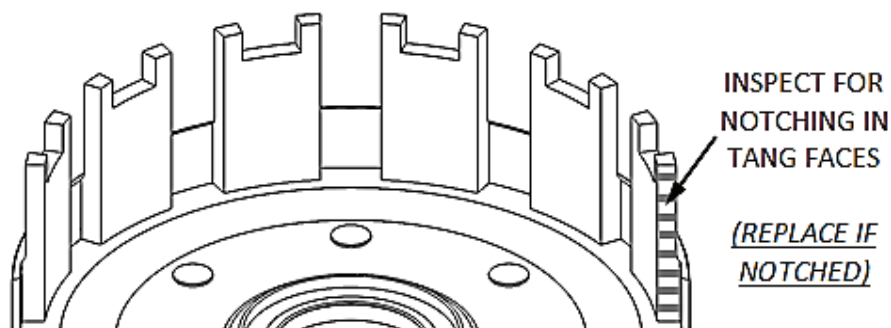

- *Inspect your OE center hub and pressure plate flanges for excess wear. If wear is visible use a drop gauge to verify that the wear across the flange does not exceed .005" (.12mm).*

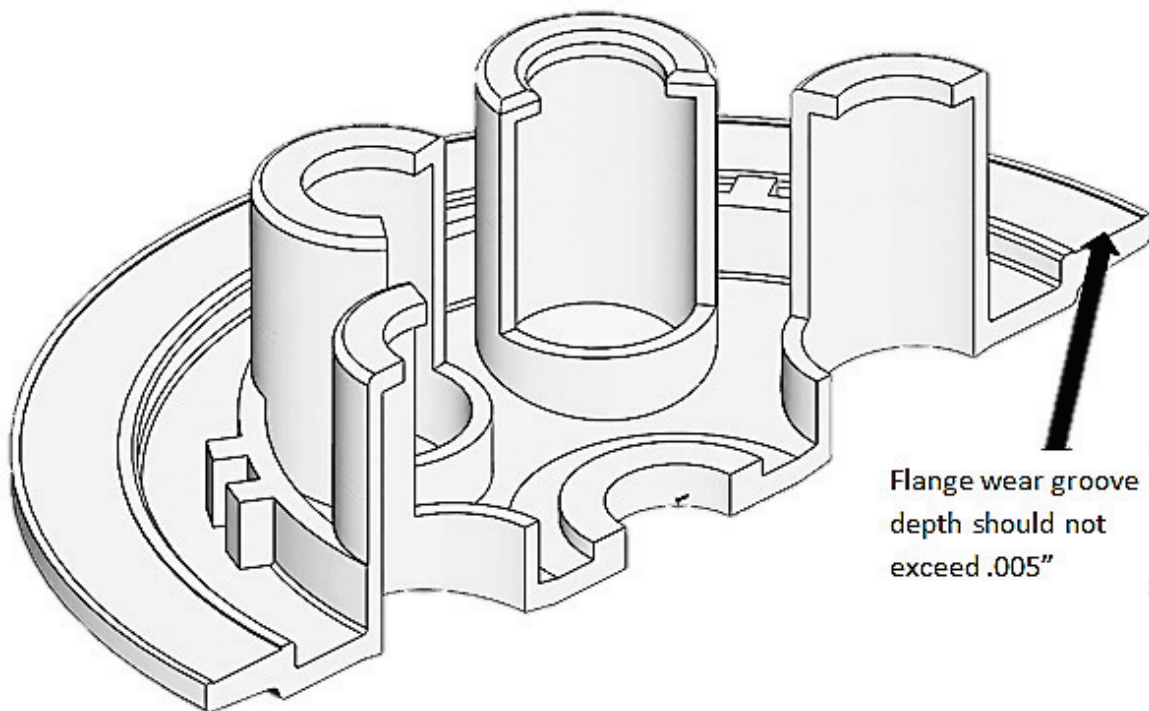
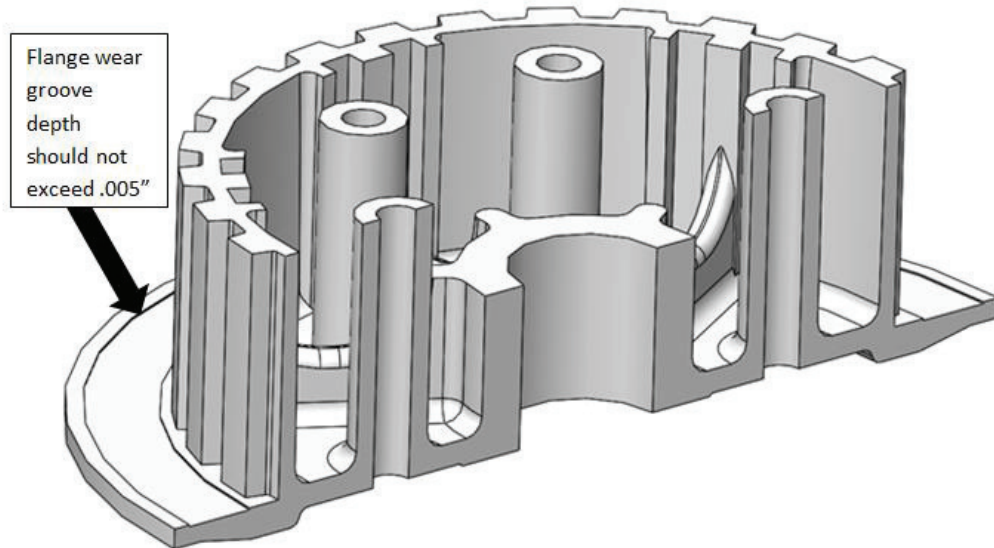

Install Clutch Pack

1. Install all of the Rekluse basket sleeves into the basket slots. Make sure the bottom of the sleeve is facing down, and the sleeve tabs sit against the inside of the basket. See following pictures for reference.

Sleeve tabs sit inside the basket

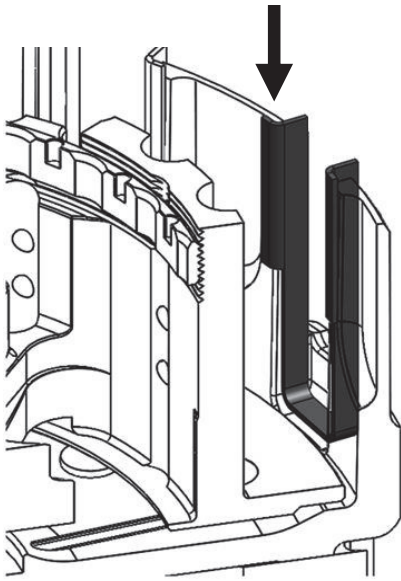

Install all the basket sleeves

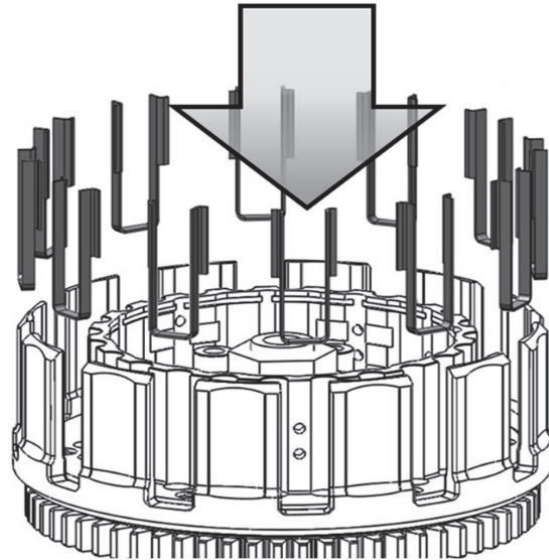

Note: When seated in the basket, the sleeve tops may sit slightly above or below the top of the basket.

2. Install the Rekluse clutch pack. The clutch pack varies depending on the bike model. **See the Setup Sheet located at the back of the manual for the proper clutch pack configuration.**

3. Reinstall the throw-out and pressure plate, then install the Rekluse pressure plate springs and bolts. If your kit includes Rekluse screw sleeves or spring bolts, install them in place of the OE components. If not, reuse the OE components.

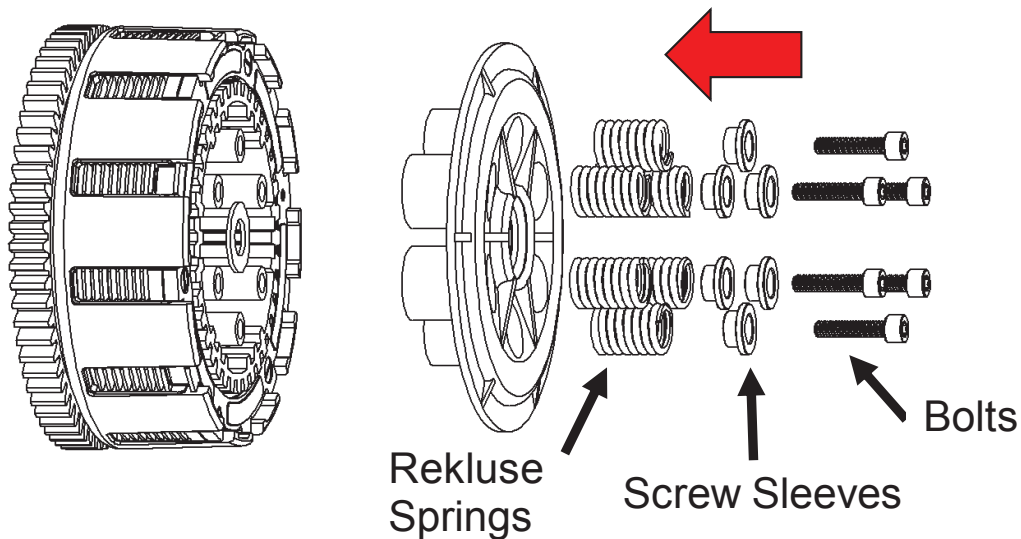

Note: *If the clutch kit includes 2 different colors of springs, be sure to alternate the springs. This will ensure even pressure on the clutch.*

4. Torque the pressure plate bolts in small increments in a star pattern to OE specifications.
5. Install the clutch cover gasket based on your bike model.

CLUTCH COVER INSTALLATION

Before securing the clutch cover in place or reattaching the clutch cable bracket to the engine, follow the next steps to achieve the correct actuator arm orientation to ensure adequate cable travel during use.

Note: *The clutch actuation mechanism is a rack and pinion system. Ensure the pinion gear and rack are oriented correctly when installing the cover. If the clutch actuation mechanism uses a hook throw-out system, then move to step 3.*

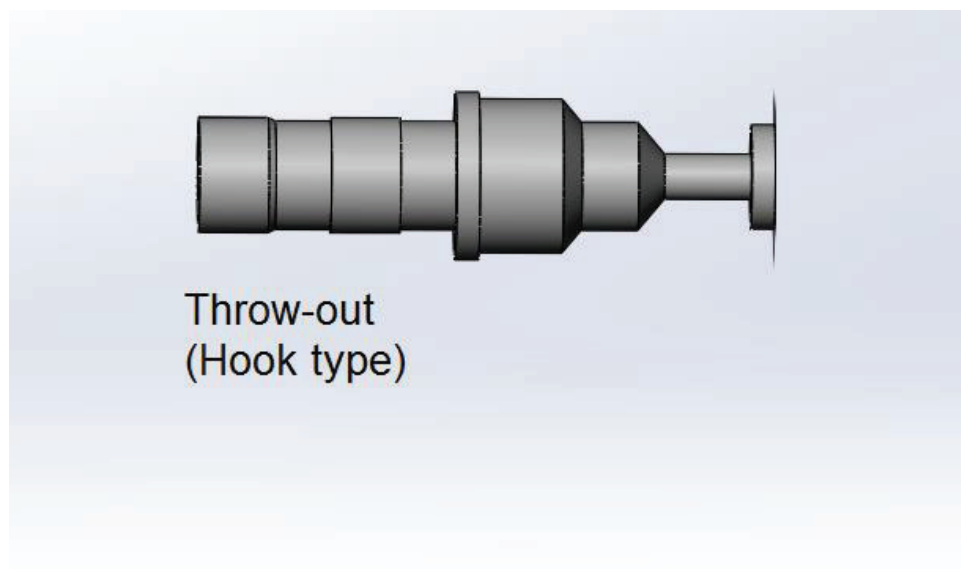
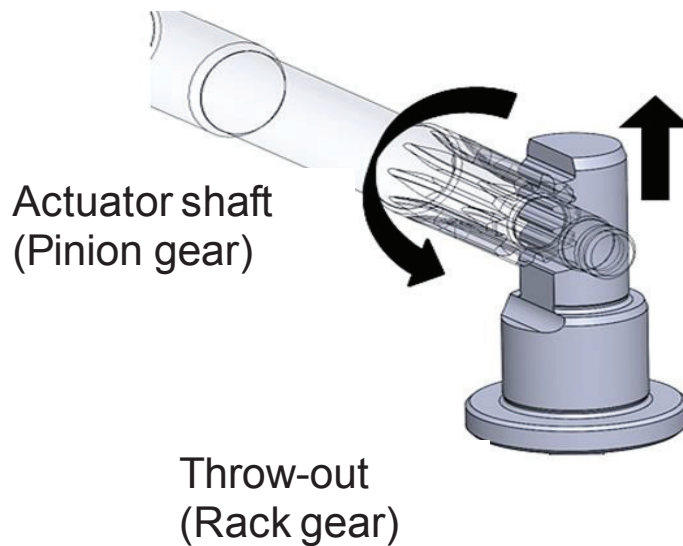

1. Align the teeth on the throw-out with the teeth on the actuator shaft in the clutch cover. Replace the clutch cover carefully, ensuring the throw out rod connects with the actuator shaft.

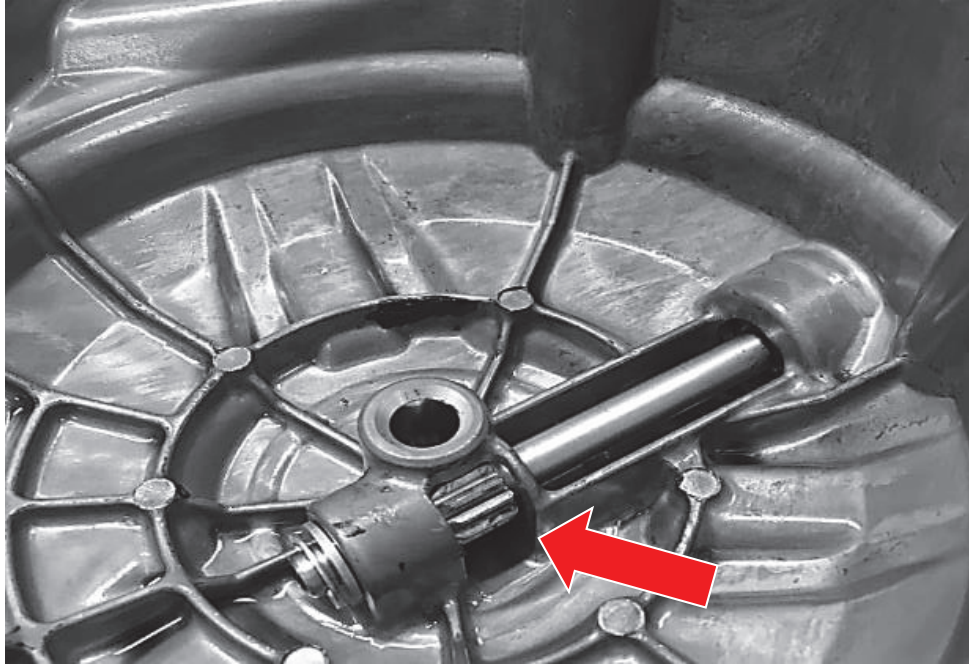

Note: Yamaha R3 models only: An additional adjustment is required for the actuator arm on this bike. Remove the snap ring from the actuator arm and move the arm *one tooth counterclockwise*. Reinstall the actuator arm and then the snap ring.



2. The actuator arm should be aligned so that when the cable is reattached the arm is in the position that was noted before installation.

Note: Ensure it matches the position that was noted on *your bike specifically* as it may differ on other bikes.

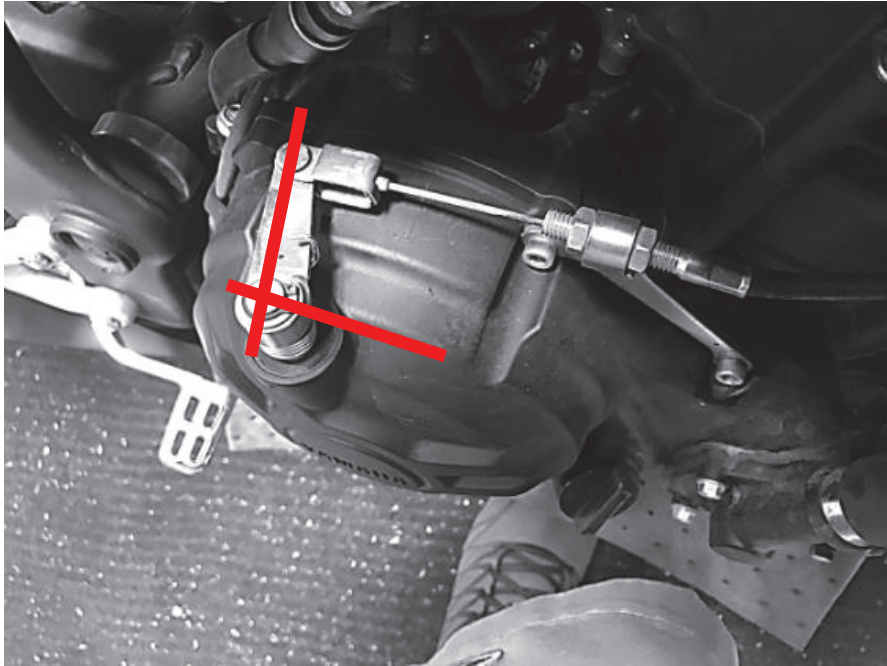

- a. If the actuator arm is in the correct position, continue with the step 3.
 - b. If the actuator arm is not in the correct position, gently pull the cover off and move the actuator shaft one gear tooth on the throw-out. Replace the clutch cover and recheck the actuator arm position.
3. When the actuator arm is in the correct positioned, lightly tighten the cover bolts in a star pattern. Torque the bolts in small increments before tightening all the bolts to OE specifications.
 4. Reattach the clutch cable to the actuator arm.

SET THE INSTALLED GAP

1. The clutch lever should be tight against the perch. If not, adjust the cable so that the lever is tight against the perch.
2. Turn the cable and/or perch adjuster 3-5 turns tighter. Tightening beyond the initial perch adjustment creates the installed gap.
3. Continue the installation by checking for Free Play Gain.

CHECK FREE PLAY GAIN

The proper installed gap is verified by checking Free Play Gain.

Correct Free Play Gain = Correct installed gap

Setup, break-in, and rechecking the installed gap is CRUCIAL. Failure to properly maintain your installed gap can result in premature wear or failure of your clutch.

⚠ WARNING

Failure to check and verify Free Play Gain can cause failure or damage to this product. Setting the correct installed gap is critical for clutch performance.

Learn how to check Free Play Gain

If you are familiar with checking Free Play Gain, check for Free Play Gain then skip to the “Adjust the Installed Gap” section.

If Free Play Gain is new to you, follow the instructions below to help you learn this important step. You can also view the video entitled “How to Check Free Play Gain” on our website at www.rekluse.com/support/videos.

Optimal Free Play Gain yields 1/8” -1/4” (3 mm-6 mm) of clutch lever movement, measured at the ball end of the

lever. This measurement at the lever correlates to achieving the ideal installed gap.

Two Ways to Check for Free Play Gain

There are two ways to check for Free Play Gain. One way uses the rubber band Rekluse includes in the clutch kit, and one uses your hand. You can use either method to check for Free Play Gain.

The Rubber Band Method

Use the rubber band method for the initial set up. It can also be used before each ride until you feel comfortable checking the Free Play Gain using the hand method.

⚠ WARNING

BEFORE YOU BEGIN, verify that the bike is in NEUTRAL before checking Free Play Gain. Failure to do so may result in the bike lurching forward, and loss of control and/or injury may result.

A Rekluse auto-clutch can make your motorcycle appear to be in neutral when in gear, even when the engine is running and clutch lever released.

Motorcycles equipped with a Rekluse auto-clutch can move suddenly and unexpectedly and cause riders to lose control. To avoid death, serious injury, and/or property damage, always sit on the motorcycle to start it.

- a) Before you begin, place the bike in **NEUTRAL**, start the engine and let it warm up for 2-3 minutes to idle down and warm the engine oil.

- b) Stretch the included rubber band between your thumbs, and then place the top end of the rubber band on the outer end of the left handlebar grip.



- c) While holding the top end of the rubber band against the handlebar, stretch the band downward, and then loop it through itself.



- d) Pull the band through the loop, and then attach it to the outside end of the clutch lever.



- e) While still in **NEUTRAL**, quickly rev the engine between 6,000-9,000 RPM (1/2 to 3/4 throttle), then let it return to idle. Notice the movement in the clutch lever when the engine is revved. This is your Free Play Gain.

Note: *It is very important the motor returns to idle before revving the engine again or Free Play Gain will not be correct.*

- f) When the bike returns to idle, rest your hand across the clutch lever. Rev the engine again to 6,000-9,000 RPM so you can observe the movement while feeling for Free Play Gain with your hand.

The Hand Method

- a) Before you begin, place the bike in **NEUTRAL**, start the engine and let it warm up for 2-3 minutes to idle down and warm up the engine oil.
- b) With the bike at idle, use one finger to apply pressure at the end of the clutch lever.
- c) While still in **NEUTRAL**, continue to apply light pressure and quickly rev the engine between 6,000-9,000 RPM (1/2 to 3/4 throttle), then let it return to idle. Notice the

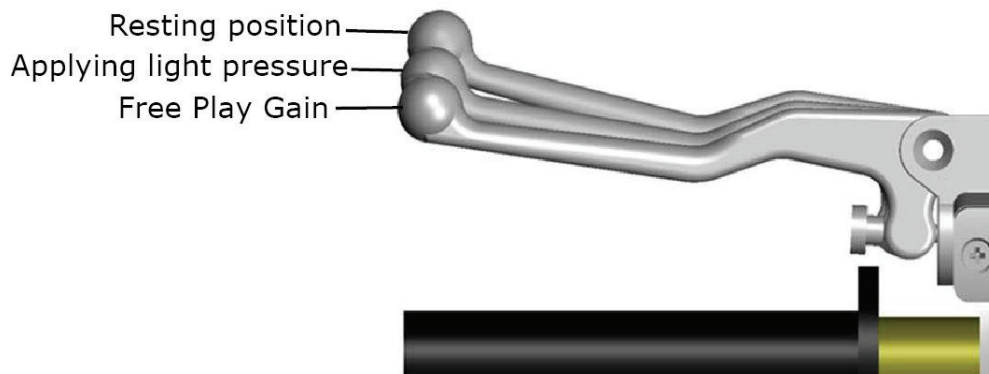

movement in the clutch lever when the engine is revved. This is your Free Play Gain.

- d) When the bike returns to idle, rev the engine between 6,000-9,000 RPM a second time to verify the Free Play Gain again.

ADJUST THE INSTALLED GAP

After checking for Free Play Gain, you may need to adjust the installed gap. If Free Play Gain is optimal, continue to “Break In The New Clutch”. If Free Play Gain is not optimal, the installed gap needs to be adjusted.

The installed gap should be fine-tuned in small increments and then recheck Free Play Gain. Refer to the table below to set the proper installed gap based on your Free Play Gain.

Notes: *If you are unable to obtain the correct Free Play Gain or you are nearly out of cable adjustment after performing the adjustment, your cable may be worn or stretched from wear or use. If this is the case, purchasing a new cable should provide the necessary performance.*

Adjust the Installed Gap

Symptom	Reason	Solution
<ul style="list-style-type: none"> • Clutch lever moves in too far (too much Free Play Gain) • Clutch has excessive drag or stalls • It is difficult to fully override the clutch with the lever 	<p>Installed gap is too small</p>	<p>Tighten the cable: increase the length of the in-line cable adjuster housing until the correct amount of Free Play Gain is achieved.</p> <p>Recheck Free Play Gain.</p>
<ul style="list-style-type: none"> • Clutch lever only moves slightly or does not move at all (too little Free Play Gain) • Clutch slips • Bike seems to lose power 	<p>Installed gap is too large</p>	<p>Loosen the cable: Reduce the length of the cable housing (collapse the adjusters) until the correct amount of Free Play Gain is achieved.</p> <p>Recheck Free Play Gain.</p>



BREAK-IN THE NEW CLUTCH

Once you install your new clutch, it is important to break it in. A series of roll-on starts are used to break in the clutch. Follow these procedures for breaking in your clutch and any time new friction disks, EXP bases, Teflon pads, or wedges are installed.

⚠ WARNING

Failure to follow the break-in procedure and oil screen inspection process could cause motor oil delivery failure, which can result in motor failure, serious injury, or death.

Break-in Procedure	Number of times
<p>Rev Cycles:</p> <ol style="list-style-type: none">1. Place the bike in NEUTRAL.2. With your hand off the clutch lever, rev the engine 10 times, being sure to let it return to idle between each rev cycle.	<p>① N ② ③ ④ ⑤</p> <p>10 rev cycles</p>
<ol style="list-style-type: none">3. With the engine still running, pull in the clutch lever, then click the bike into 1st gear. Slowly release the clutch lever. The bike should stay in place or have a slight amount of forward creep.4. With the bike idling in first gear, slowly apply throttle to begin moving.	<p>Continued on next page </p>

<p>5. Without using the clutch lever, accelerate moderately to approximately 5,000 RPM to fully lock up the clutch and come to a complete stop. Repeat 10 times.</p> <p>Note: <i>If the engine wants to stall or the creep is excessive, the idle may be too high or the installed gap may be too small. Make necessary adjustments before proceeding.</i></p>	 <p>10 roll-on starts</p>
<p>6. Without using the clutch lever, start in 2nd gear, then accelerate moderately to approximately 5,000 RPM and come to a complete stop. Repeat 10 times.</p>	 <p>10 roll-on starts</p>
<p>7. Place the bike in NEUTRAL and recheck Free Play Gain.</p> <p>8. Continue to step 4 to adjust the installed gap until the Free Play Gain of the clutch lever is 1/8" to 1/4" (3 mm-6 mm).</p>	 <p>Recheck Free Play Gain and adjust the installed gap</p>

Note: *Your clutch pack will expand with heat, so final adjustment to Free Play Gain should be made when the bike is warm. Remember not to ride without sufficient Free Play Gain.*

CAUTION

Do not perform 3rd gear starts with this product. Starting in 3rd gear will burn up the clutch and decrease the performance of this product in a short amount of time.

CLUTCH LEVER OPTIMIZATION

If your bike model is not equipped with a perch adjuster bolt, you may purchase, as an option, a Rekluse Adjustable Reach Lever.

Adjust the lever:

- Set the clutch lever to the desired reach point while maintaining clutch lever slack.
 - Turning your adjuster bolt farther in will bring the lever closer to the bar and allow for a closer reach point.
 - Backing your adjuster bolt farther out will push the lever farther from the bar and allow for a further reach point.

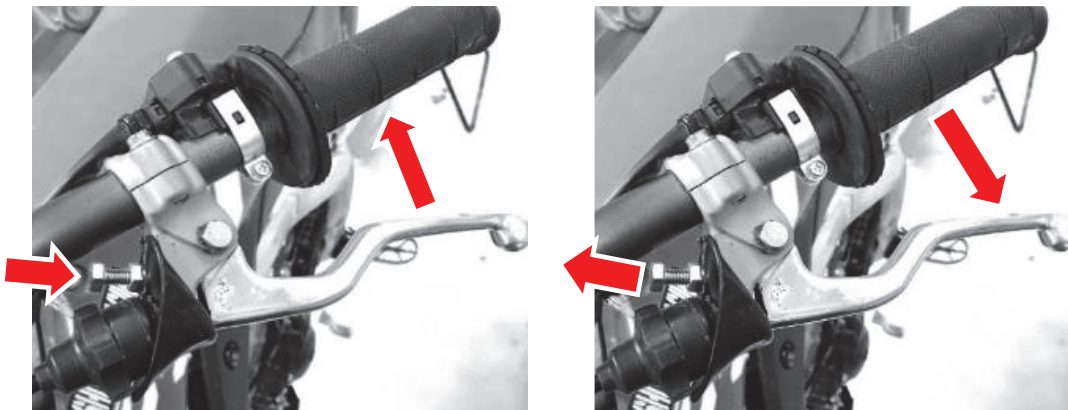

Optimization with Rekluse Adjustable Reach Lever

Set the clutch lever to the desired reach point while maintaining clutch lever slack.

- Turning your adjuster bolt farther in will push the lever farther from the bar and allow for a further reach point.

- Backing your adjuster bolt farther out will bring the lever closer to the bar and allow for a closer reach point.

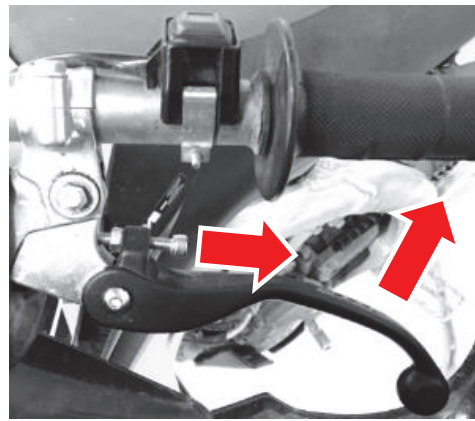
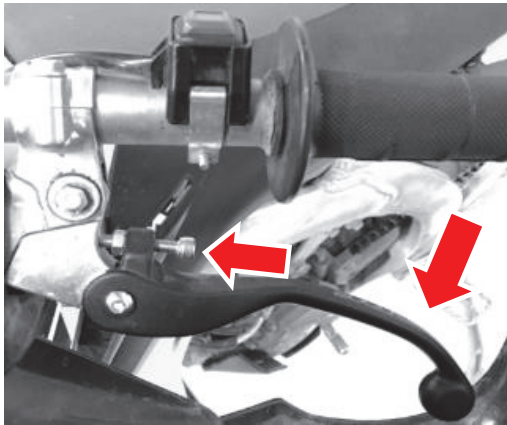

MAINTENANCE

To keep your clutch performing at its best, perform regular maintenance on your bike and clutch.

Clutch wear

Rekluse clutches are built using high quality materials but do wear based on the rider's use, type of terrain, and natural wear and tear. To keep your clutch performing at its best, perform regular maintenance on your bike and clutch based on your riding style.

- Maintain adequate Free Play Gain. Check before every ride and adjust as necessary.
- Repeat the break-in procedure anytime you replace any components of the EXP disk or frictions disks. Always soak new friction disks in fresh oil before installing.

Clutch parts

- Inspect all of your clutch parts at regular intervals for signs of wear or excessive heat, and replace components as necessary. Rekluse recommends inspecting after the first 10 hours of use, then every 20 hours after that.

- Measuring the clutch pack and/or the EXP disk can help determine if the components need replacing.
- Replace friction disks or drive plates if they are glazed and/or burnt. See the following sections for examples.
- Keep up with regular oil changes as per the bike manufacturer's recommendations. Clutch performance and longevity depend on oil quality. Oil recommendations can also be viewed under Tech Tips on our website at www.rekluse.com/support/videos.

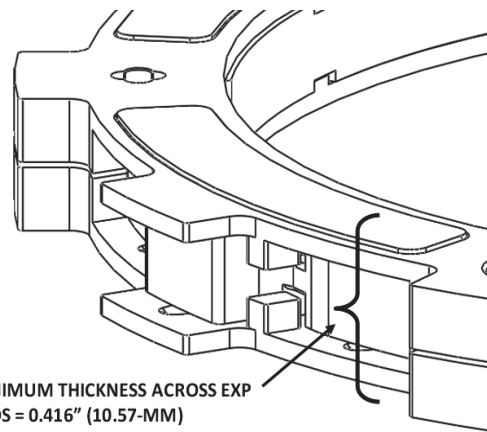

Basket

- Inspect the basket dampers and/or springs by checking the play between the ring gear and the basket. Replace the dampers/springs if you feel any play in the assembly.
- Inspect and replace basket sleeves if they appear to be notched from friction disks. Rekluse recommends replacing them every 25 hours for abusive riding/racing, every 50 hours for moderate riding, or every time friction disks are replaced.

Disk inspection examples

When inspecting the clutch pack, the following pictures can be used as a reference. **These are best viewed in color by viewing this install document at www.rekluse.com/support.**

Drive Plates – If the clutch pack is getting high amounts of heat, purple, blue, or black color can be seen on the drive plate teeth. See pictures below. Not all drive plates look the same and may look different than pictured.

Normal Heat

High Heat

Excessive Heat



(Blue)

(Black)

Friction Disks – Due to the dark color of the friction material, the friction disks will appear almost black as soon as they are put in oil. During inspection, look for glazing of the friction material. Glazing will appear shiny and feel like glass, even after oil is cleaned from the friction disk. Not all friction disks look the same and may look different than pictured.



Normal
Friction



Glazed
Friction

NEED ADDITIONAL HELP?

Website

www.rekluse.com/support

Frequently asked questions

www.rekluse.com/faq

Support Videos

www.rekluse.com/support/videos

Phone

(208) 426-0659

Technical Support

Contact Technical Support for questions related to product installation, tuning, and performance.

Hours:

Monday thru Friday: 8:00 a.m. - 5:00 p.m.

Mountain Time zone

Email: tech@rekluse.com

Customer Service

Contact Customer Service for additional product information, orders, and returns.

Hours:

Monday thru Friday: 8:00 a.m. - 5:00 p.m.

Mountain Time zone

Email: customerservice@rekluse.com



SETUP SHEET 198-6307090

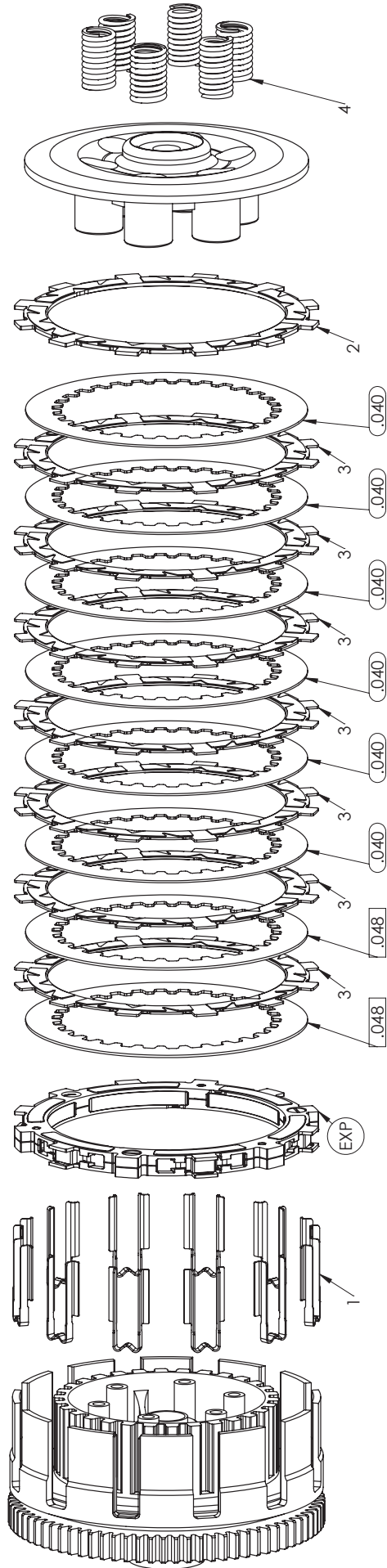

ITEM NO.	DESCRIPTION	QTY
1	BASKET SLEEVE	12
2	THICK FRICTION DISC	1
.040	DRIVE PLATE (.040")	7
.048	DRIVE PLATE (.048")	2
3	TORQDRIVE FRICTION DISC	6
EXP	EXP DISC	1
4	REKLUSE SPRINGS	6

COVER GASKET
No gasket is needed for this product

* Note: The MEDIUM setting is preinstalled into the EXP disc.

ENGAGEMENT RPM SETTING	SPRING CONFIGURATION
LOW	3 SILVER & 3 RED
MEDIUM*	6 RED
HIGH	3 RED & 3 BLUE

