



REKLUSE[®]

EXP[™]

REKLUSE MOTOR SPORTS

The Rekluse EXP Clutch

INSTALLATION GUIDE

Doc ID: 191-6177

Revision: 040519

OVERVIEW

All OEM components will be reused except:

- One stock friction disk will be replaced with the Rekluse EXP disk.
- The stock pressure plate will be replaced with the Rekluse pressure plate and lining plate.
- The throw out will be reconfigured to work with the included needle bearing assembly.



INSIDE THIS DOCUMENT

- INSTALLATION TIPS
- TOOLS NEEDED
- INCLUDED PARTS
- INSTALLATION INSTRUCTIONS
 - PRE-INSTALLATION ADJUSTMENTS
 - PREP AND DISASSEMBLY
 - EXP INSTALLATION
 - SETTING THE INSTALLED GAP
 - CHECKING FREE PLAY GAIN
 - BREAK-IN PROCEDURE
- MAINTENANCE
- TROUBLESHOOTING GUIDE
 - FREE PLAY GAIN TROUBLESHOOTING
 - OPTIMIZING EXP ENGAGEMENT

INSTALLATION TIPS

- Protect eyes and skin – wear safety glasses and thin disposable work gloves.

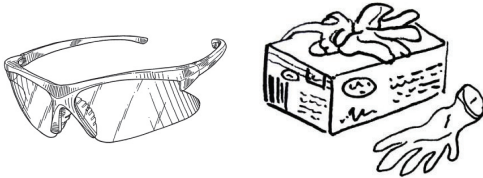

- Work in a ventilated area.
- Turn the fuel petcock to “OFF.”

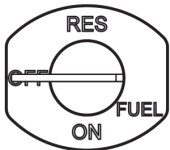



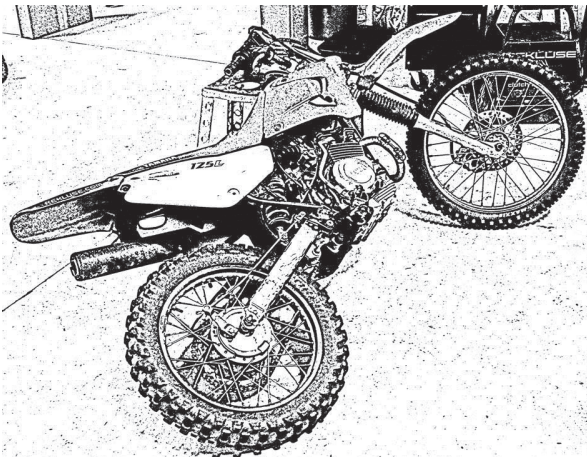



- Lay the bike on its left side to avoid draining the oil. Catch fuel that may drain from vent tubes.



- For optimal clutch performance Rekluse recommends using fresh, clean oil that **meets JASO-MA** oil rating requirements. Rekluse offers Factory Formulated Oil™ developed specifically for Rekluse products. Rekluse Factory Formulated Oil is a perfect complement to any OEM or aftermarket wet clutch. Visit www.rekluse.com to learn more.

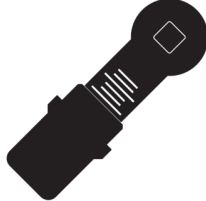

TOOLS NEEDED

 <p>6 mm</p>	 <p>8 mm</p>	 <p>10 mm</p>	 <p>19 mm</p>
<p>6mm Allen key</p>	<p>8mm socket</p>	<p>10mm end wrench (x2)</p>	<p>19mm end wrench</p>
			
<p>Phillips screwdriver</p>	<p>Motor oil</p>	<p>Torque wrench</p>	

INCLUDED PARTS

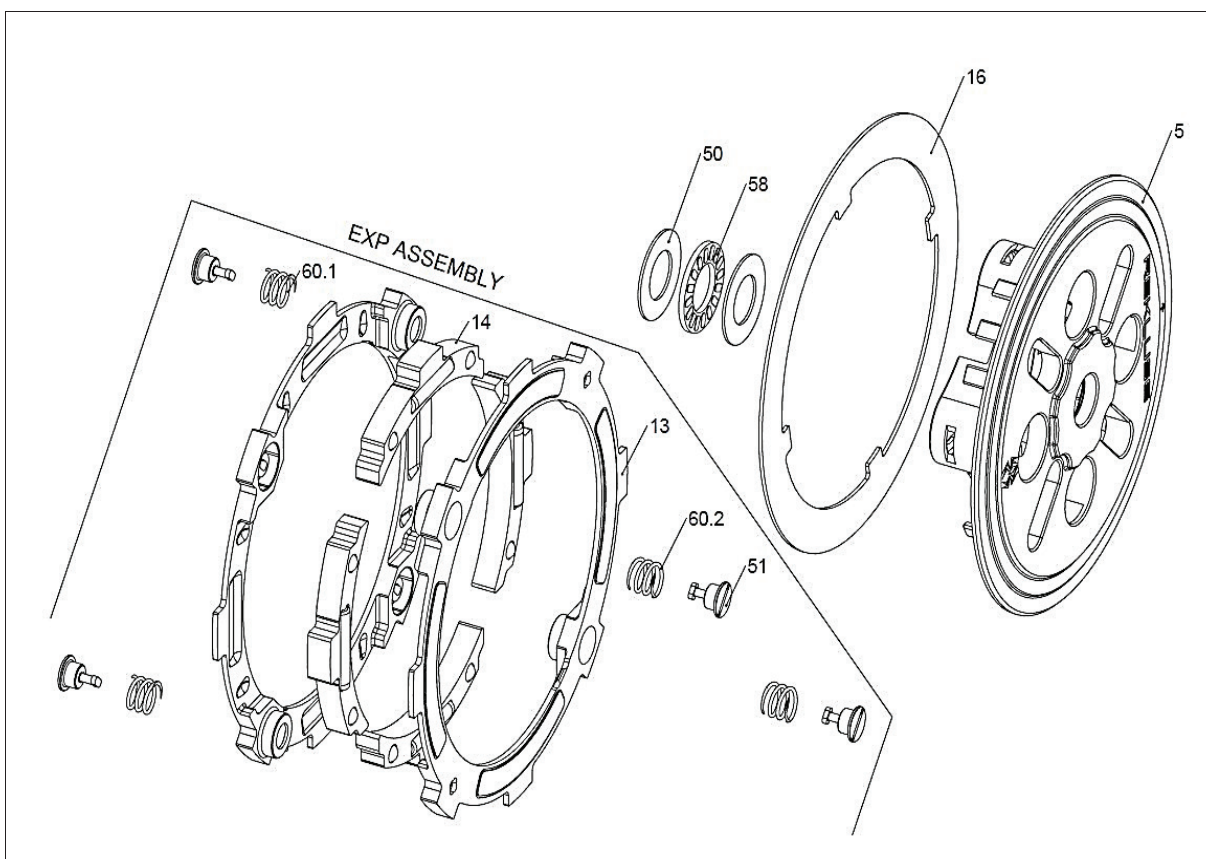

Item	Part Number	Description	Qty.
5	113-013A	Pressure Plate	1
13	140-218B	EXP Base	2
14	741-023B	Wedge Assembly	4
16	143-013B	Lining Plate	1
50	414-130	Hardware – Washer	2
51	415-000	Fastener – ¼-turn Pin	4
58	433-302	Thrust Bearing	1
60.1	442-001	EXP Spring	4
Not Shown	419-121	Black FPG Rubber Band	1

INSTALLATION INSTRUCTIONS

PRE-INSTALLATION ADJUSTMENTS

Adjust the in-line cable adjuster and perch adjuster so it is **midway** through its adjustable range.

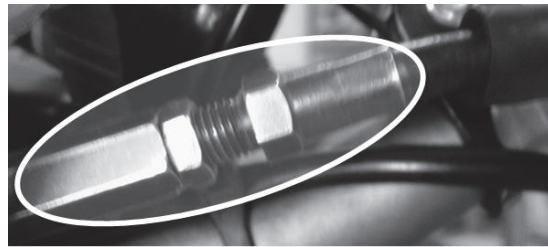
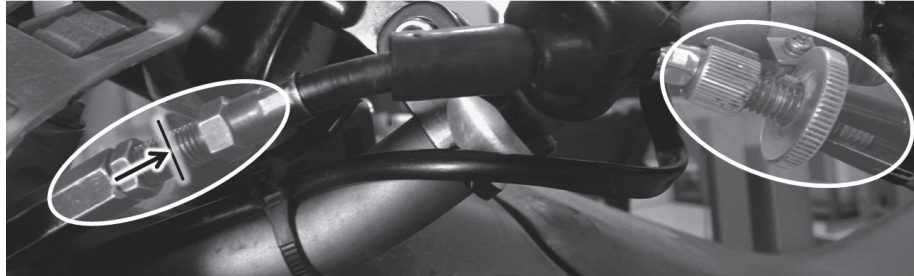

ADJUSTED TO MIDWAY

PREP AND DISASSEMBLY

1. Soak the EXP disk in engine oil for 5 minutes

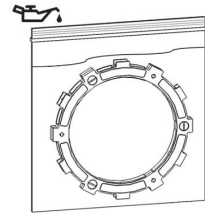

2. Turn the fuel petcock to "OFF" and lay the bike on its left side.

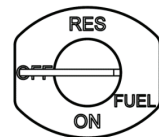

3. Remove the kick starter nut and slide the kick starter off the splined shaft.

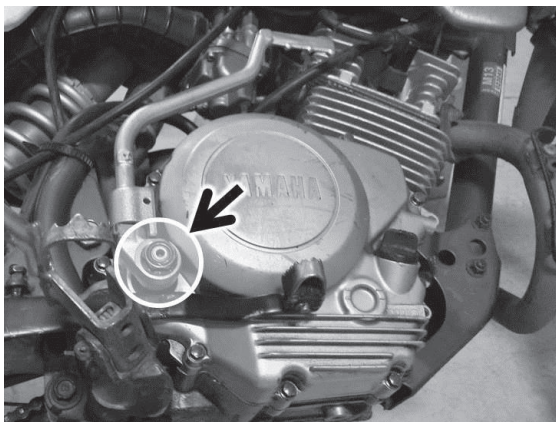

19 mm

4. Remove the brake pedal pivot bolt and swing the pedal out of the way. NOTE: There is a washer on the backside of the bolt between the pedal and the frame.

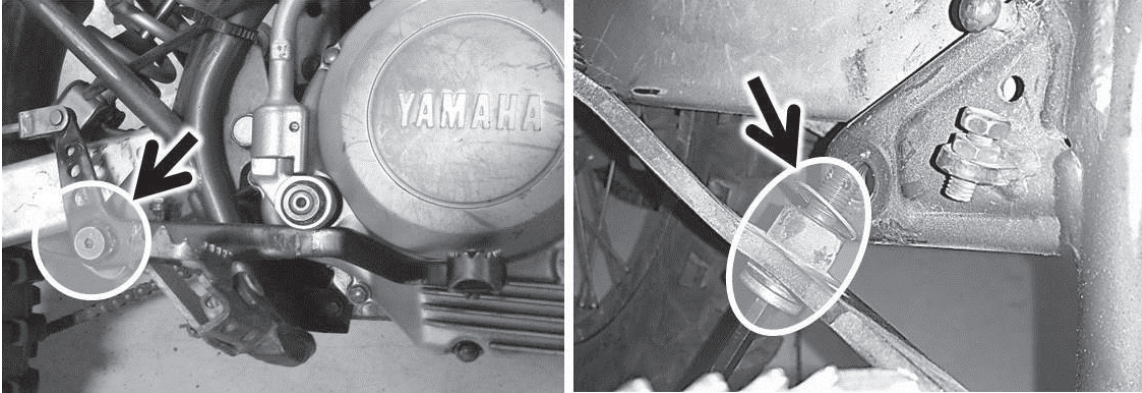

5. Remove the 9 side case bolts and remove the side case.

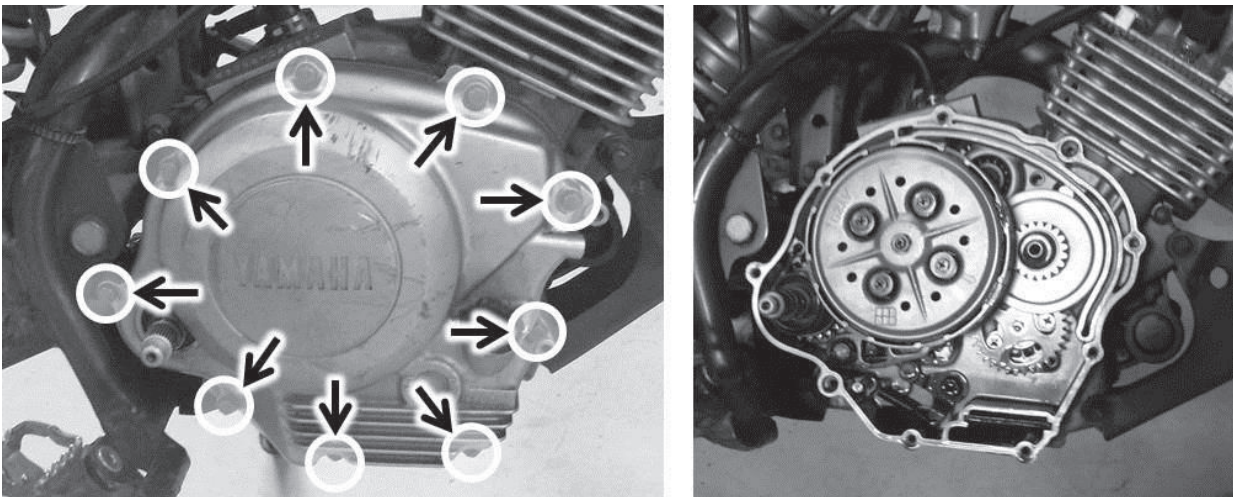

NOTE: Inspect the OEM side case gasket. If the gasket is damaged or torn it will need to be replaced before Final Installation.

6. Remove the pressure plate screws along with the springs and pressure plate assembly. The springs and bolts will be reused.

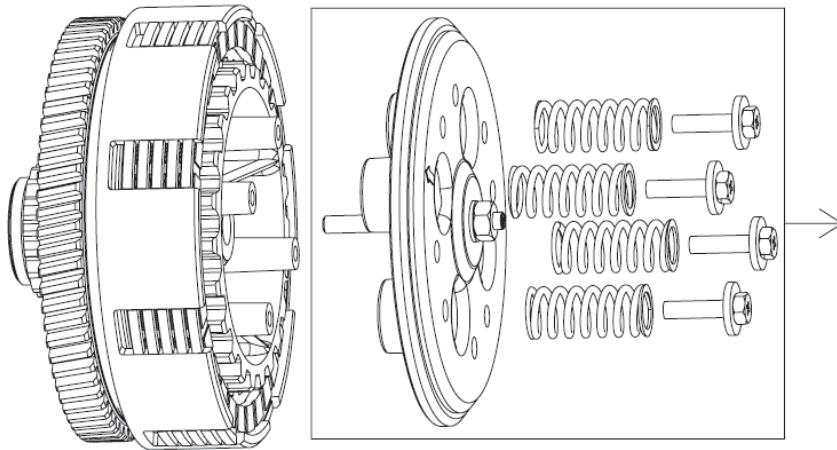

7. Remove the throw out from the stock pressure plate by removing the top nut and washer. Secure the top nut and washer to the underside of the shoulder washer. For a starting point, tighten the underside nut with one thread exposed.

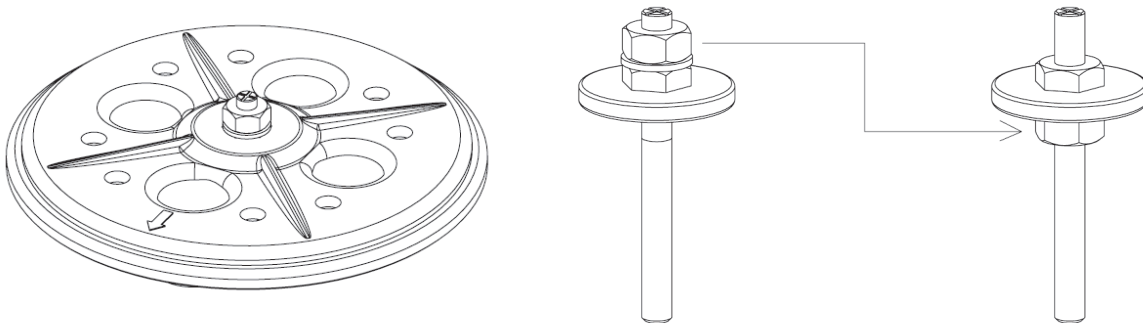

NOTE: Begin with the throw-out in this configuration. If you run out of cable adjustment in the later steps to correctly set the installed gap, the top nut may need to be moved back to its original position. (The top nut and washer above the shoulder washer.)

8. Remove the top friction disk.

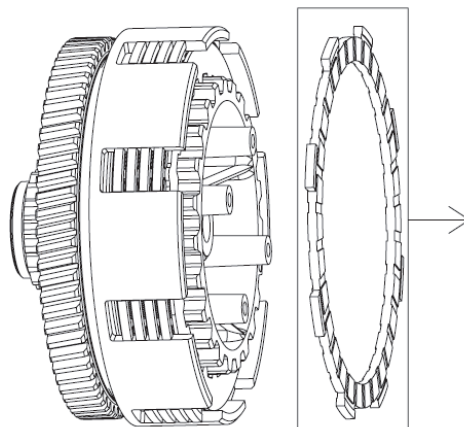

EXP INSTALLATION

9. Insert the EXP disk in place of the removed OEM friction.

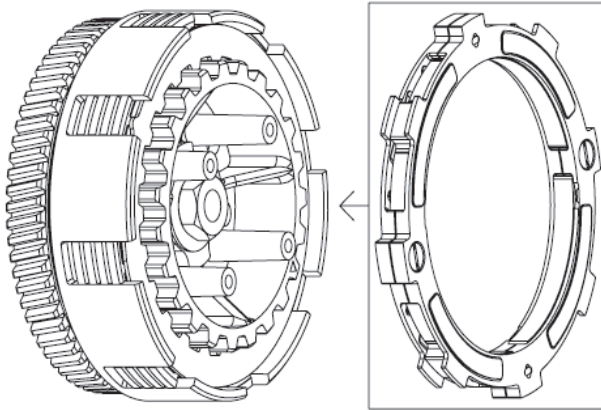

10. Install the reconfigured throw out (step 7) followed by the needle bearing assembly.

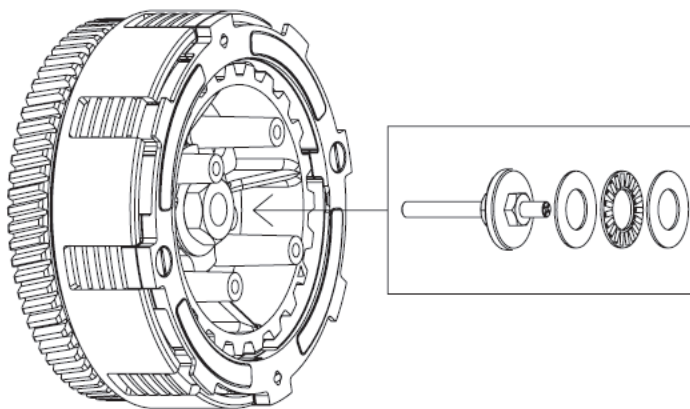

11. Couple the lining plate and pressure plate, using a thin film of oil between the surfaces to keep the lining plate in place. Make sure the arrow on the pressure plate is aligned with the triangle on the center hub, and set it down on the clutch pack.

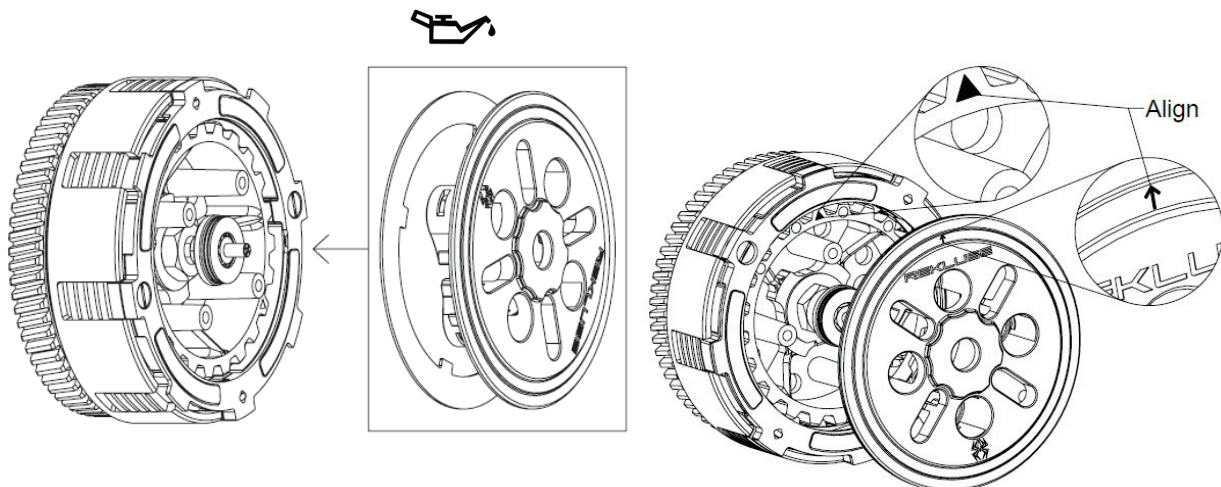

Proceed to SETTING THE INSTALLED GAP.

SETTING THE INSTALLED GAP

The installed gap is critical for this product to function correctly. Follow these instructions carefully. The gap is first set roughly using the adjustable throw out and then fine-tuned with the cable after the side case is attached.

12. Make sure the arrow on the pressure plate is aligned with the triangle on the center hub. Set the pressure plate (with lining plate) down on the clutch pack. It should rest on the needle bearing assembly without contacting the EXP disk.
13. Install the OEM pressure plate springs and screws. Tighten two opposing screws in 3-turn increments so the pressure plate will go down evenly. Then tighten the two remaining screws. **Torque to 50 in-lb (5.7 N-m).**
14. Check the installed gap – the distance between the pressure plate and the lining plate – with feeler gages. Checking with 2 sets of gages at 180° apart works best. This measurement should be between **0.023-0.028” (0.58-0.71mm)**. If the gap is not in range, undo the screws, adjust the throw out and repeat steps 12-14 until the correct gap is achieved.
 - a. To adjust the throw out, remove the pressure plate and the needle bearing assembly. Remove the throw out and unthread the shoulder bolt a few turns. Use a 10mm end wrench to hold the shoulder position while tightening the bottom nut with another 10mm end wrench. Reinstall the throw out with needle bearing assembly.
 - b. Throw out thread = M4 x 0.7. One full turn = 0.7mm (0.027 in.). If the pressure plate is flush on the clutch pack and there is no slop in the throw out, the shoulder nut should be turned out 1 full turn to achieve a .027” gap.
15. After setting the installed gap:
 - a. Remount the side case (torque to 78 in-lb (8.8 N-m))
 - b. Remount kick starter
 - c. Remount brake pedal

CHECKING FREE PLAY GAIN

16. Turn fuel petcock to "ON" and start the bike. Let it warm up.

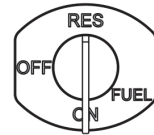

17. There are 2 methods to check free play gain: rubber band method or hand method. First, use the rubber band method to understand the concept of free play gain. Then, become comfortable with the hand method so you can use it as the primary method to check free play gain in the future.

Make sure the transmission is in neutral when checking free play gain.



• RUBBER BAND METHOD

Wrap the included rubber band around the outer end of the handlebar grip and attach it to the ball end of the clutch lever. With the transmission in neutral, rev the engine to 5000 rpm and observe the lever movement. The lever should move in about **1/4"-3/8" (6-9mm)**.

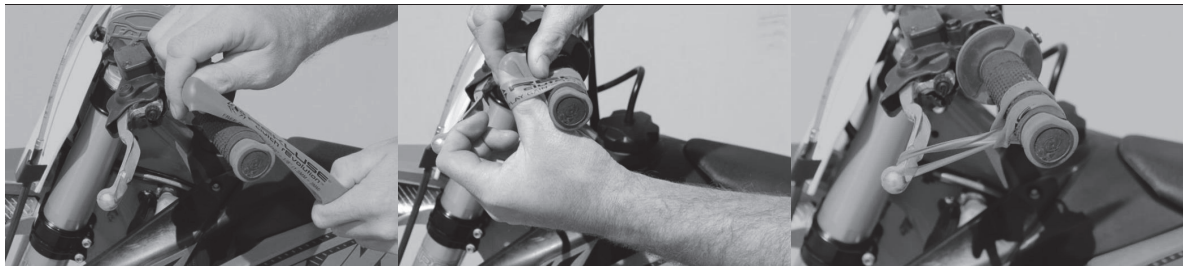

• HAND METHOD

Use your finger instead of the rubber band. Place light pressure on the clutch lever and rev the engine to 5000 rpm. The lever should move in about 1/4" (6.35mm).

18. If free play gain is optimal, proceed to the BREAK-IN PROCEDURE. If free play gain is not optimal, use the in-line cable adjuster or perch adjuster to achieve the correct amount.

- **TOO MUCH FREE PLAY GAIN?** The installed gap is too small. Increase the length of the cable housing (extend the adjusters) until the correct amount of free play gain is achieved.
- **NOT ENOUGH FREE PLAY GAIN?** The installed gap is too large. Reduce the length of the cable housing (collapse the adjusters) until the correct amount of free play gain is achieved.
- **STILL HAVING TROUBLE?** Refer to the TROUBLESHOOTING GUIDE for more information.

BREAK-IN PROCEDURE

After desired free play gain is achieved, it is time to break in the EXP disk.

-
19. REV CYCLES: With the transmission in neutral and no pressure on the clutch lever, rev the engine to about 5000 rpm and let it return to idle. Perform 10 rev cycles.



-
20. ROLL-ON STARTS: Pull in the clutch lever and click the transmission into first gear. Slowly release the clutch lever. The engine should stay running and the bike should have minimal forward creep. If the engine wants to stall or the creep is excessive, the idle may be too high or the installed gap may be too small. Make necessary adjustments before proceeding.

- a. FIRST GEAR: Slowly roll on the throttle to begin moving. Accelerate to around 5000 rpm and come to a stop. Perform 5 first gear roll-on starts.



- b. SECOND GEAR: Click the transmission into second gear and perform 5 roll-on starts.



-
21. Re-check free play gain and adjust if necessary.

IMPORTANT: Check Free Play Gain before every ride.

NOTE: Do not perform 3rd gear starts with this product. 3rd gear starts over time will burn up the clutch and decrease the performance of this product in a short amount of time.

MAINTENANCE

Maintenance Protocol	Maintenance Interval
Check and verify free play gain	Every ride
Inspect all clutch parts for excessive wear or heat. Replace as needed.	40 hours

TROUBLESHOOTING GUIDE

FREE PLAY GAIN TROUBLESHOOTING

Free play gain is the visual representation of the installed gap in the clutch pack. As the EXP disk expands, it fills the installed gap and then pushes on the pressure plate to engage the clutch. This pressure plate movement is seen and felt at the lever when light finger pressure is applied during a rev cycle.

Free play gain should be fine-tuned in small increments using the clutch cable in-line adjuster and perch adjuster. After each cable adjustment, perform a few rev cycles in neutral with light pressure on the lever to re-check free play gain.

- **COLLAPSE THE CABLE HOUSING** to reduce cable tension, thus relaxing the throw out and decreasing the installed gap in the clutch – this will **INCREASE FREE PLAY GAIN**.
- **EXPAND THE CABLE HOUSING** to increase cable tension, thus pushing the throw out into the pressure plate and increasing the installed gap in the clutch – this will **REDUCE FREE PLAY GAIN**.

If the cable housing reaches the fully collapsed or fully expanded state and free play gain is still not optimal, the side case may need removed to make coarse adjustments with the throw out.

OPTIMIZING EXP ENGAGEMENT

For best performance, engine idle speed should be adjusted to match the EXP engagement setting.

NOTE: Make sure Free Play Gain is optimal before adjusting idle speed.

With correct Free Play Gain and the bike in gear, the bike should move forward under slight opening of the throttle. If not, one of the following symptoms is likely:

- **HIGH IDLE** – the bike moves forward with the throttle fully closed. Solution: reduce idle RPM.
- **LOW IDLE** – the bike moves forward after engine RPM becomes noticeably higher than idle RPM. Solution: increase idle RPM.