



REKLUSE[®]

EXP[™]

REKLUSE MOTOR SPORTS

The Rekluse EXP Clutch

INSTALLATION GUIDE

Doc ID 191-6142
Revision 060120

OVERVIEW

All OEM components will be reused except:

- The stock friction disk with judder spring and seat will be replaced with the Rekluse EXP disk.
- The stock drive plates will be replaced with Rekluse drive plates.
- The stock center hub will be replaced with the Rekluse center hub.
- The stock clutch springs will be replaced with Rekluse springs.



©2019 Rekluse Motor Sports
Rekluse Motor Sports, Inc.
12000 W Franklin Rd.
Boise, ID 83709
208-426-0659
support@rekluse.com

INSIDE THIS DOCUMENT

- INSTALLATION TIPS
- TOOLS NEEDED
- INCLUDED PARTS
- INSTALLATION INSTRUCTIONS
 - PREP AND DISASSEMBLY
 - CLUTCH PACK ASSEMBLY
 - FINAL INSTALLATION
 - SETTING THE INSTALLED GAP
 - CHECKING FREE PLAY GAIN
 - BREAK-IN PROCEDURE
- MAINTENANCE
- TROUBLESHOOTING GUIDE
 - FREE PLAY GAIN TROUBLESHOOTING
 - OPTIMIZING EXP ENGAGEMENT

INSTALLATION TIPS

- Protect eyes and skin – wear safety glasses and thin disposable work gloves.

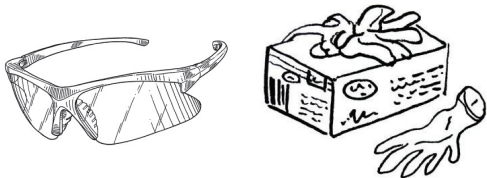

- Work in a ventilated area.
- Turn the fuel petcock to “OFF.”

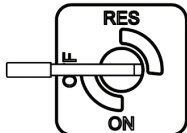



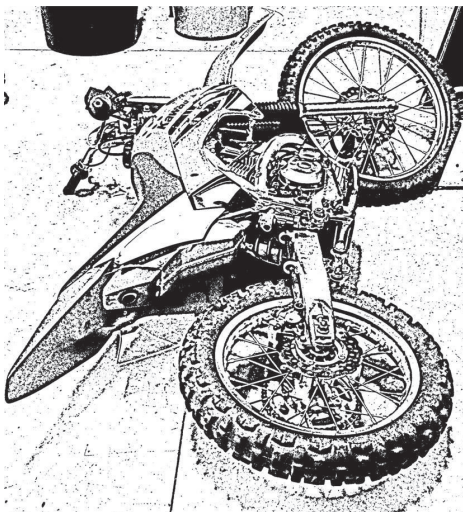







- Lay the bike on its left side to avoid draining the oil. Catch fuel that may drain from vent tubes.



- For optimal clutch performance Rekluse recommends using fresh, clean oil that **meets JASO-MA** oil rating requirements. Rekluse offers Factory Formulated Oil™ developed specifically for Rekluse products. Rekluse Factory Formulated Oil is a perfect complement to any OEM or aftermarket wet clutch. Visit www.rekluse.com to learn more.

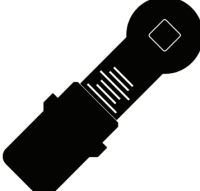

TOOLS NEEDED

 4 mm	 8 mm	 8 mm	 10 mm
4mm Allen key	8mm Allen key	8mm socket	10mm socket
 14 mm		 8 mm	 12 mm
14mm socket	Impact gun	8mm end wrench	12mm end wrench (x2)
			
Torque wrench	Motor oil		

INCLUDED PARTS

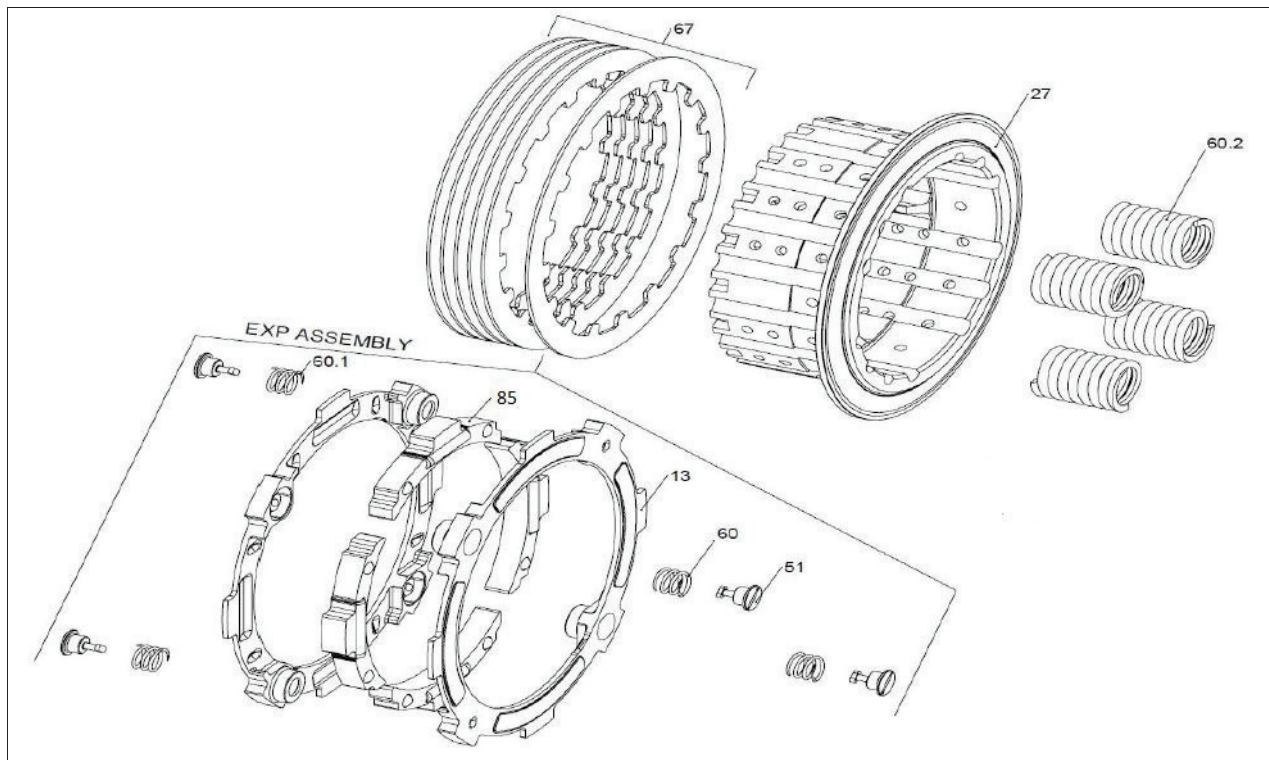

Item	Part Number	Description	Qty.
13	140-219B	EXP Base	2
27	178-040A	Center Clutch	1
51	415-000	Fastener – ¼-turn Pin	4
60	442-001	EXP Spring - Silver	2
60.1	442-007	EXP Spring - Steel	2
60.2	442-112	Clutch Spring	4
67	465-410A	Drive Plate	5
85	741-050B	Wedge Assembly	4
Not Shown	419-121	Black FPG Rubber Band	1

INSTALLATION INSTRUCTIONS

PREP AND DISASSEMBLY

Read through these instructions to understand the procedure before beginning. Follow these instructions carefully to ensure proper installation and function of the product.

1. Soak the EXP disk in engine oil for 5 minutes.

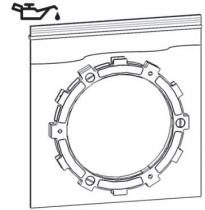

2. Turn the fuel petcock to "OFF" and lay the bike on its left side.

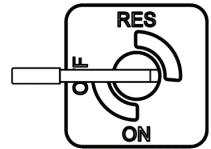

3. Remove the brake pedal bolt and swing the pedal out of the way.

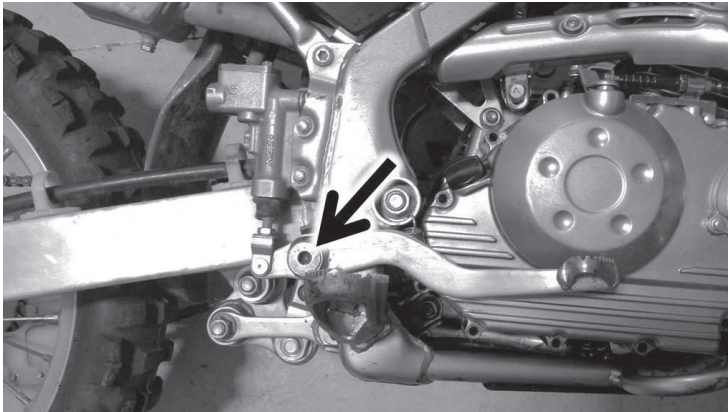

4. Remove the heat shield from the exhaust pipe. This allows the clutch cable to be adjusted more easily.

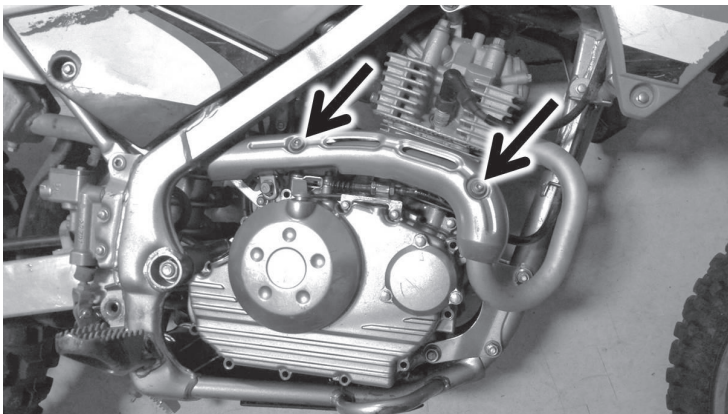

5. Loosen the in-line cable adjuster all the way. First loosen the 12mm Jam Nut (closest to actuator arm) and thread it away from the bracket, then hold the cable housing with an 8mm wrench and turn the 12mm Adjuster Nut away from the bracket until the cable is completely slack.

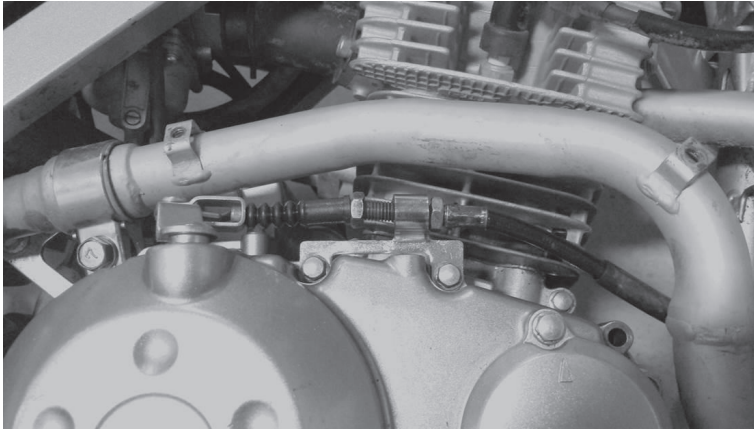

6. Remove the two bolts from the cable bracket.



7. Detach the clutch cable from the actuator arm and swing the cable out of the way.

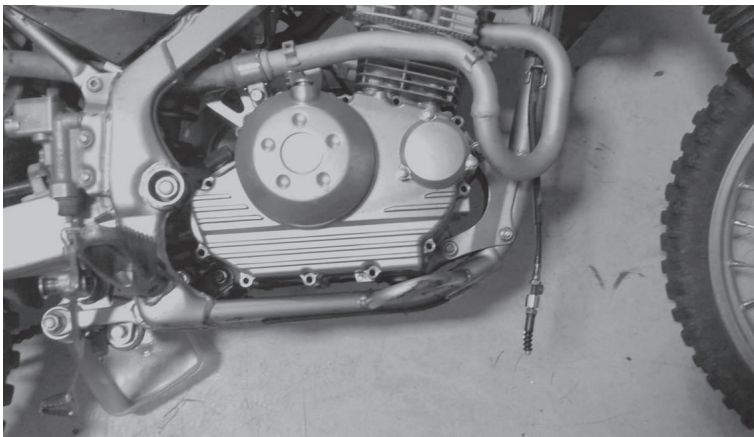

8. Remove the remaining side case bolts and pull off the side case. NOTE: Make sure the throw out stays inside the case.



NOTE: Inspect the OEM side case gasket. If the gasket is damaged or torn it will need to be replaced before Final Installation.

9. Remove the bearing from the center of the push plate.



10. Remove the center clutch bolt which can be accessed through the center of the push plate after the bearing is removed.

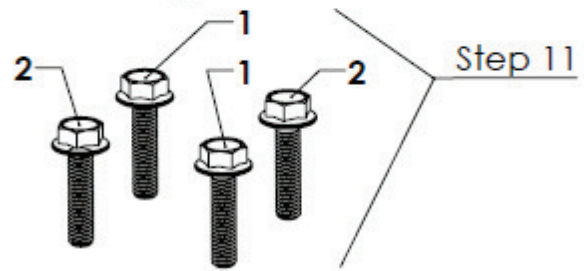
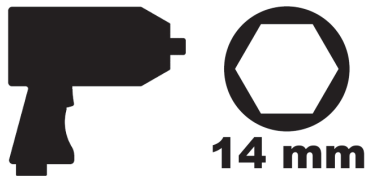

11. Carefully remove the 4 bolts from the push plate. Use an alternating pattern between opposing bolts (1-1, 2-2, 1-1, 2-2, etc.) turning each bolt 3 turns before switching to the next, until the springs are relaxed.

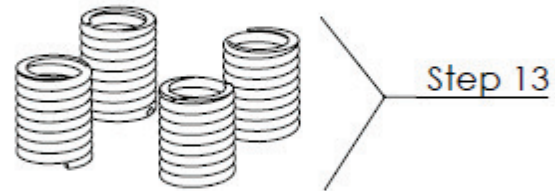
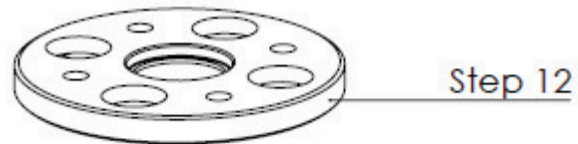

12. Remove the push plate.

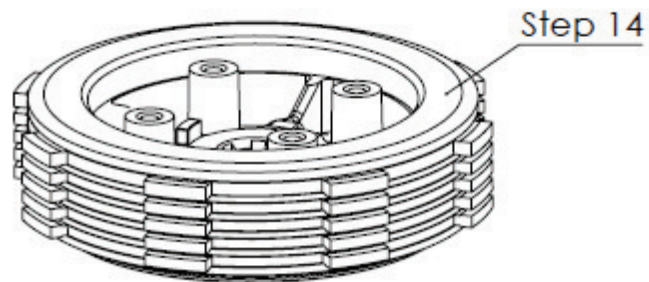

13. Remove the 4 clutch springs. These will NOT be re-used.

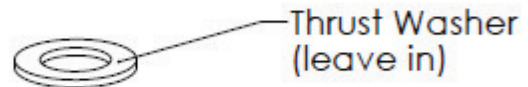

14. Pull up on the pressure plate posts to remove the internals of the clutch. Leave the basket and thrust washer on the main shaft.

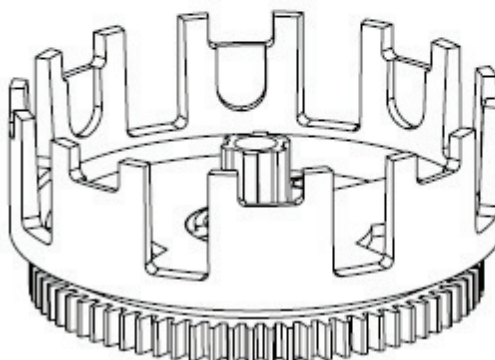

15. Place the clutch upside down on a workbench.

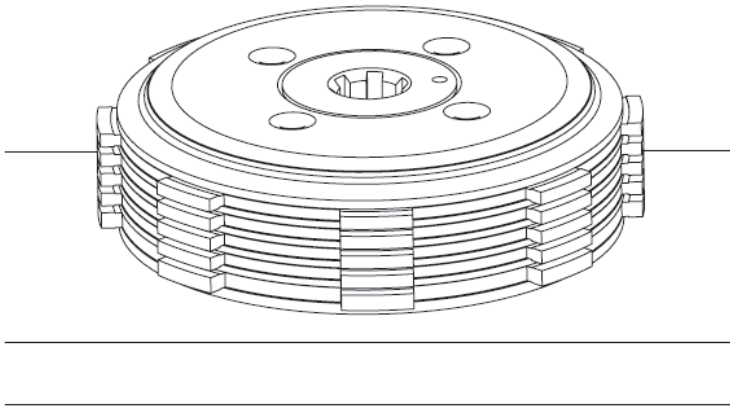

16. Pull the pressure plate off the clutch pack.

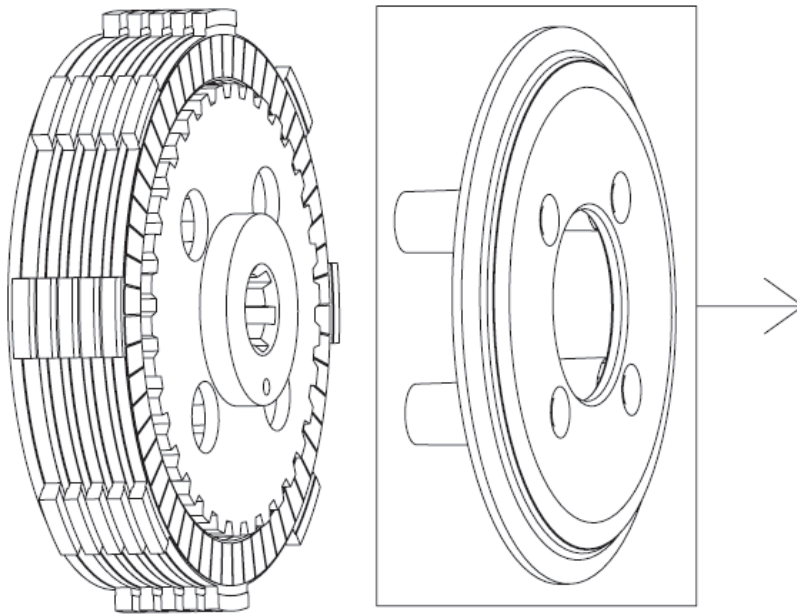

17. Pull off the clutch pack, including the judder spring and seat on the center hub flange. Separate the frictions and drive plates – all OEM frictions will be re-used except the judder spring disk.

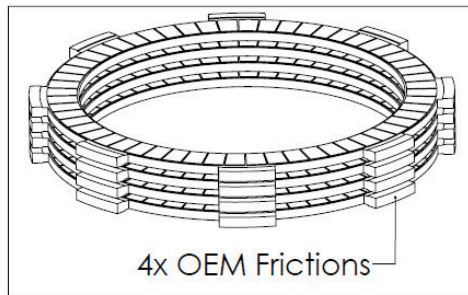
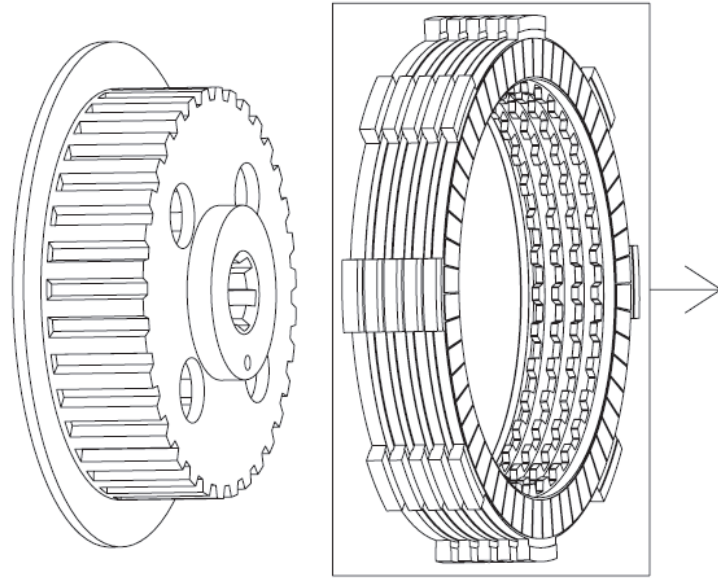

RE-USE

SET ASIDE

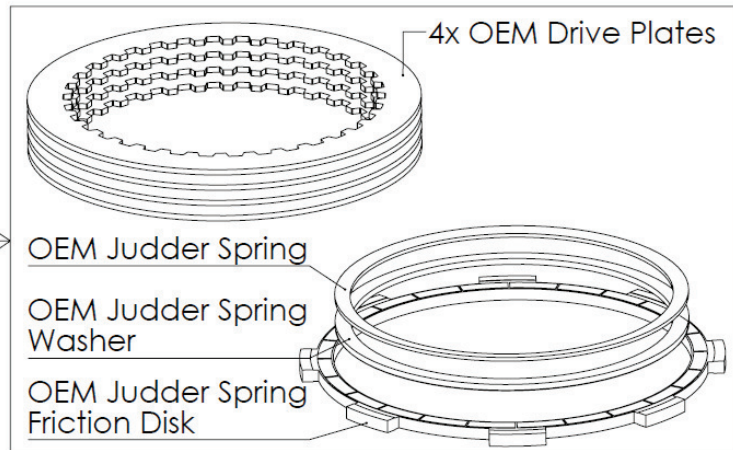

CLUTCH PACK ASSEMBLY

18. Place one Rekluse drive plate onto the Rekluse center hub.

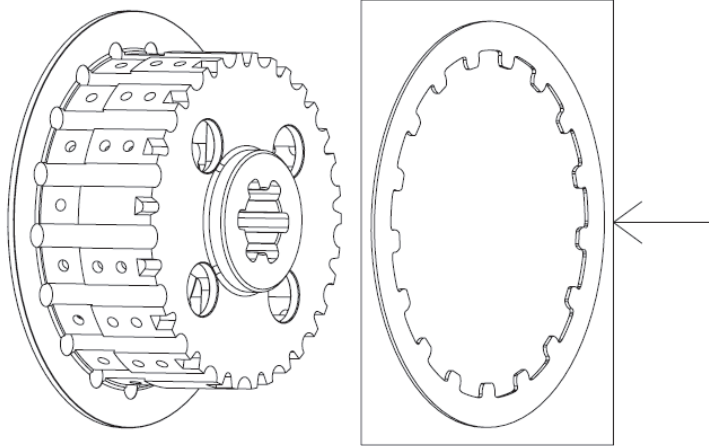

19. Place the EXP disk on next, followed by another Rekluse drive plate. NOTE: The EXP may fit tightly at first, but it will be looser at the bottom where it sits during operation.

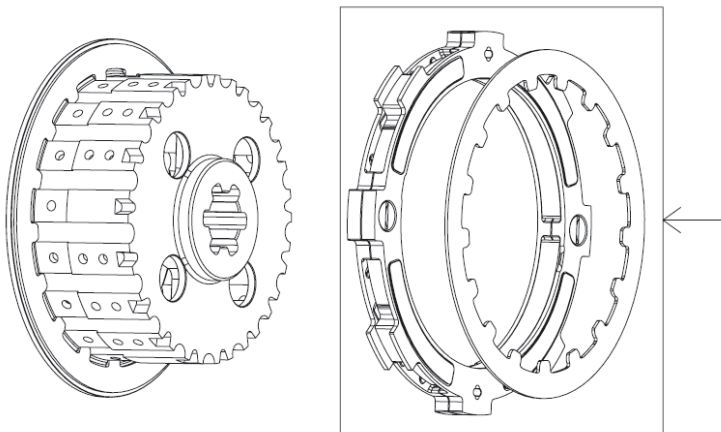

20. Now add one OEM friction, followed by a Rekluse drive plate. Continue this pattern until you have used all the Rekluse drive plates and have 4 OEM friction disks in the clutch pack. Align the friction tabs.

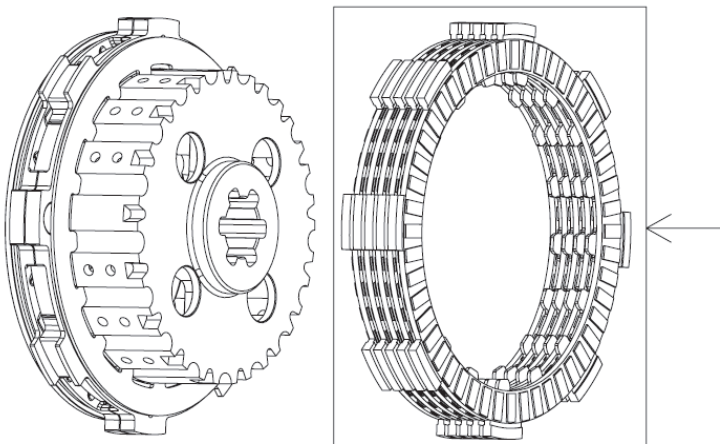

CLUTCH PACK TOTAL

1x EXP Disk

4x OEM Frictions

5x Rekluse Drive Plates

21. Index the pressure plate onto the center hub. Make sure the pressure plate teeth align with the center hub teeth.

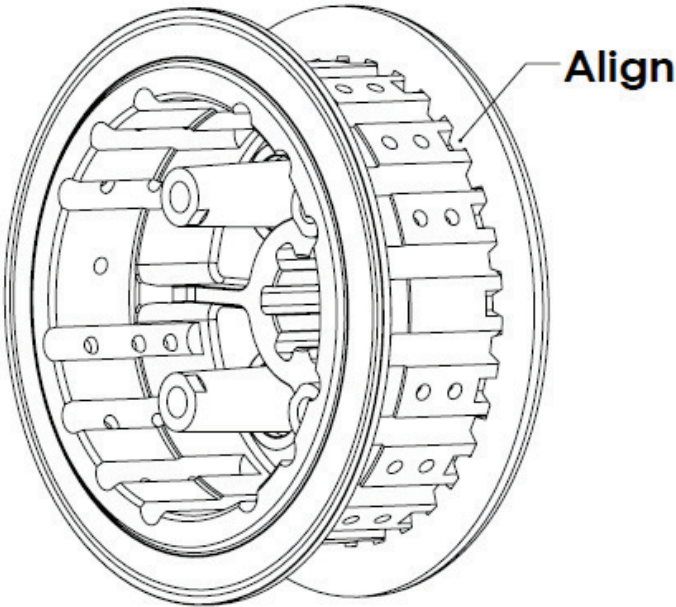
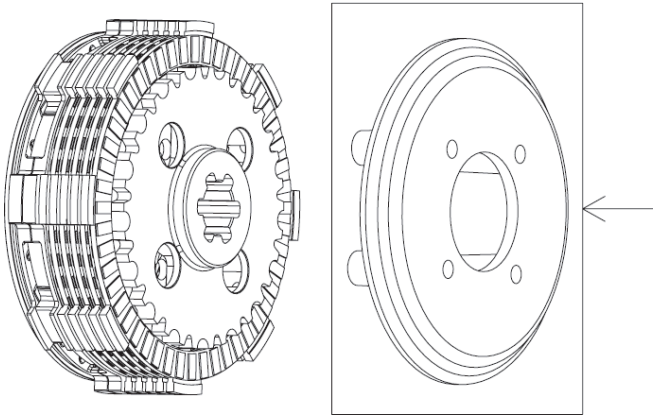

22. Install the Rekluse clutch springs, alternating colors, followed by the push plate. Install 2 opposing bolts and tighten them evenly in 3-turn increments to secure the push plate by hand. Install the other 2 bolts and tighten by hand. This will keep the clutch together when it is installed into the basket.

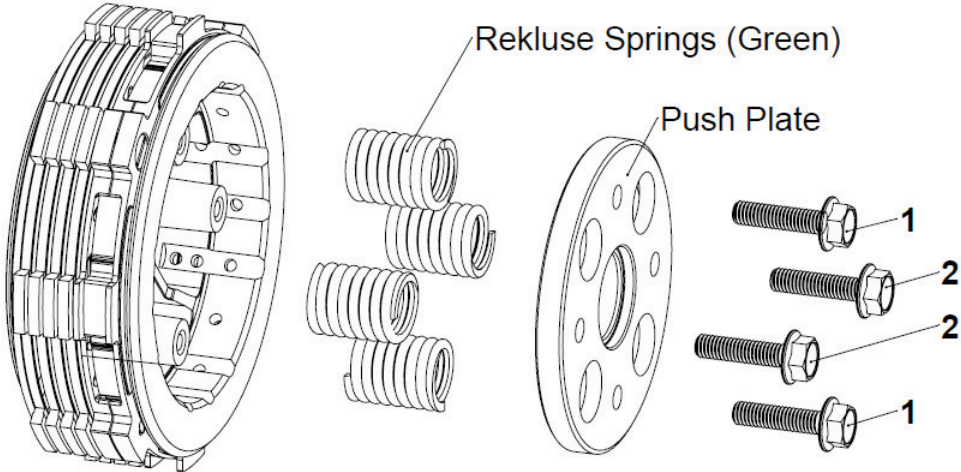

FINAL INSTALLATION

23. Install the clutch into the basket. Align the center clutch splines with the main shaft and the friction tabs with the basket slots. The push plate can be rotated to turn the center clutch so the center clutch and frictions can be aligned independently.



24. Install the center clutch bolt. Torque to 48 ft-lb (65 N-m).
25. Finish tightening the 4 bolts in the push plate evenly in 3-turn increments. Torque all 4 bolts to 78 in-lb (8.8 N-m).
26. Install the bearing into the center of the push plate.
27. **Check that the clutch is properly clamped.** If the clutch pack is still able to move, or is not currently clamped, return to clutch pack installation to ensure proper clutch pack installation.
28. Remount the side case and all side case bolts except the 2 used for the clutch cable bracket. Torque to 78 in-lb (8.8 N-m).
29. Remount the cable bracket. With the cable bracket bolts in place, push the cable bracket towards the actuator arm as much as possible and torque the bolts to 78 in-lb (8.8 N-m).

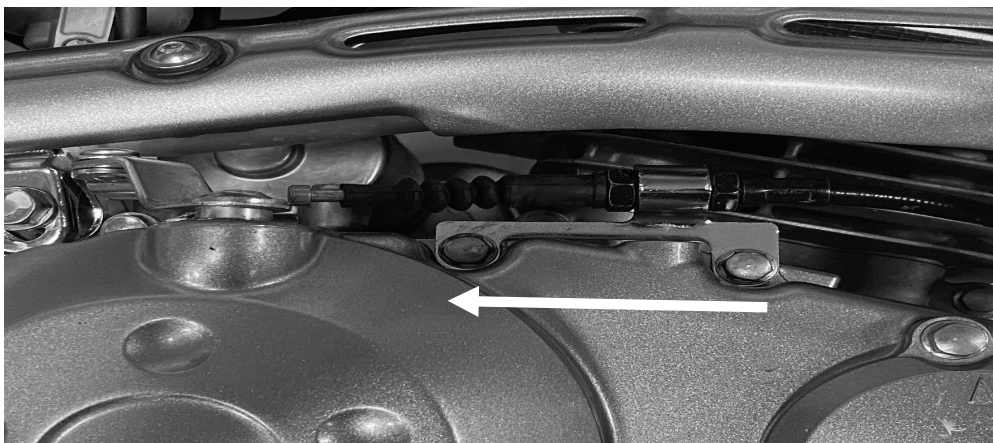

30. Attach the clutch cable to the actuator arm. Using a crescent wrench to move the actuator arm towards the cable makes attaching the cable easier.

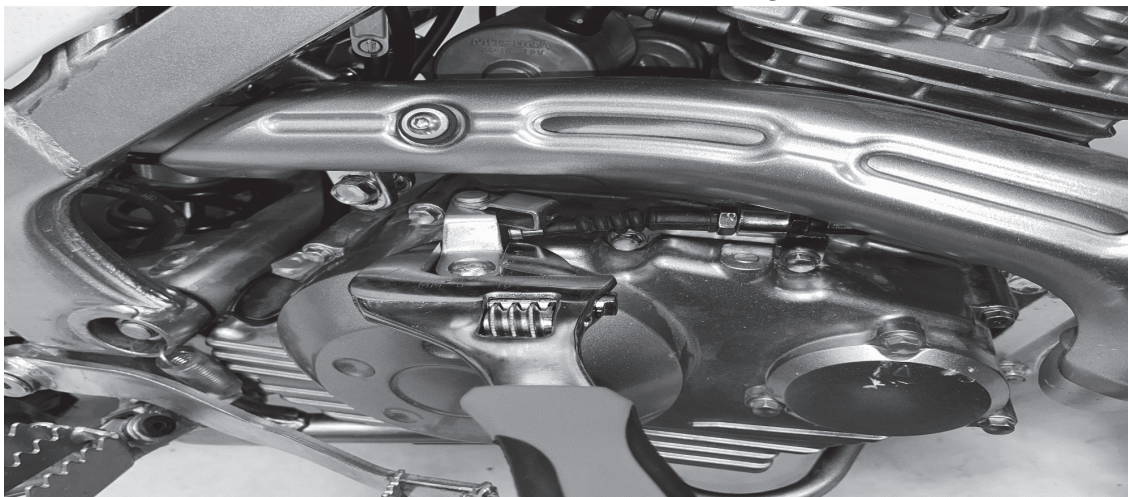

Proceed to SETTING THE INSTALLED GAP.

SETTING THE INSTALLED GAP

NOTE: Using a crescent wrench to move the actuator arm towards the cable makes adjusting the clutch cable easier.

Follow these instructions carefully. The installed gap is critical for this product to function correctly.

The gap is set using the in line cable adjuster to rotate the actuator arm, which will lift the pressure plate off the clutch pack to create the necessary gap for the auto clutch to function properly.

Refer to the diagram below to understand the terminology used in this procedure.

31. Turn the 12mm Jam Nut CW to leave room for adjusting. This will be re-tightened later.
32. Using a wrench, and *being careful not to damage the actuator arm*, turn the actuator arm towards the cable and attach the cable to the arm.
33. If the cable is already tight, proceed to next step. If there is slack in the cable, take up all the slack by turning the adjuster nut to find the point where the cable starts to become tight.
34. Set the gap – the installed gap that allows the auto clutch to function – by turning the 12mm Adjuster Nut CW 6-8 turns past the starting point. This is the initial gap setting. This adjustment will be optimized while checking free play gain in the next section.
35. Turn the 12mm Jam Nut CCW to tighten it against the cable bracket.

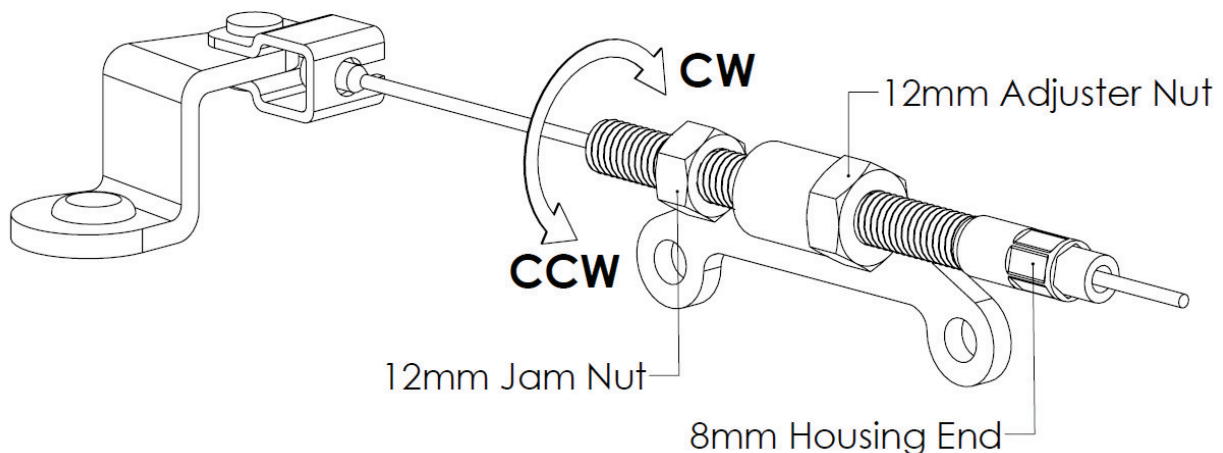

Proceed to CHECKING FREE PLAY GAIN and BREAK-IN PROCEDURE.

CHECKING FREE PLAY GAIN

36. Turn fuel petcock to “ON” and start the bike. Let it warm up.

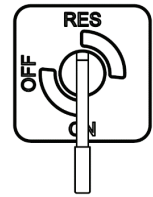

37. There are 2 methods to check free play gain: rubber band method or hand method. First, use the rubber band method to understand the concept of free play gain. Then, become comfortable with the hand method so you can use it as the primary method to check free play gain in the future.

Make sure the transmission is in neutral when checking free play gain.



• RUBBER BAND METHOD

Wrap the included rubber band around the outer end of the handlebar grip and attach it to the ball end of the clutch lever. With the transmission in neutral, rev the engine to 5000 rpm and observe the lever movement. The lever should move in about 1/8" (3mm).



• HAND METHOD

Use your finger instead of the rubber band. Place light pressure on the clutch lever and rev the engine quickly to 5000 rpm. The lever should move in about 1/8" (3mm).

38. If free play gain is optimal, proceed to the BREAK-IN PROCEDURE. If free play gain is not optimal, use the in-line cable adjuster to achieve the correct amount. See SETTING THE INSTALLED GAP for instructions.

- **TOO MUCH FREE PLAY GAIN?** The installed gap is too small. Turn the 12mm Adjuster Nut CW 1-2 turns and recheck Free Play Gain. Repeat until Free Play Gain is optimal.
- **NOT ENOUGH FREE PLAY GAIN?** The installed gap is too large. Turn the 12mm Adjuster Nut CCW 1-2 turns and recheck Free Play Gain. Repeat until Free Play Gain is optimal.
- **STILL HAVING TROUBLE?** Refer to the TROUBLESHOOTING GUIDE for more information.

BREAK-IN PROCEDURE

After desired free play gain is achieved, it is time to break in the EXP disk.

39. REV CYCLES: With the transmission in neutral and no pressure on the clutch lever, rev the engine to about 5000 rpm and let it return to idle. Perform 10 rev cycles.



40. ROLL-ON STARTS: Pull in the clutch lever and click the transmission into first gear. Slowly release the clutch lever. The engine should stay running and the bike should have minimal forward creep. If the engine wants to stall or the creep is excessive, the idle may be too high or the installed gap may be too small. Make necessary adjustments before proceeding.

a. FIRST GEAR: Slowly roll on the throttle to begin moving. Accelerate to around 5000 rpm and come to a stop. Perform 5 first gear roll-on starts.



b. SECOND GEAR: Click the transmission into second gear and perform 5 roll-on starts.



41. Re-check free play gain and adjust if necessary.

42. Reattach the exhaust shield before taking the bike on a full ride.

IMPORTANT: Check Free Play Gain before every ride.

NOTE: Do not perform starts in 3rd gear with this product. 3rd gear starts over time will burn up the clutch and decrease the performance of this product in a short amount of time.

MAINTENANCE

Maintenance Protocol	Maintenance Interval
Check and verify free play gain	Every ride
Inspect all clutch parts for excessive wear or heat. Replace as needed.	40 hours
Rekluse EXP minimum thickness	0.416"
Rekluse drive plate thickness	0.040+/-0.001"
Total clutch pack thickness	1.108+/-0.018"

TROUBLESHOOTING GUIDE

FREE PLAY GAIN TROUBLESHOOTING

Free play gain is the visual representation of the installed gap in the clutch pack. As the EXP disk expands, it fills the installed gap and then pushes on the pressure plate to engage the clutch. This pressure plate movement is seen and felt at the lever when light finger pressure is applied during a rev cycle.

Free play gain should be tuned using the clutch cable in-line adjuster and perch adjuster. After each cable adjustment, perform a few rev cycles in neutral with light pressure on the lever to re-check free play gain.

- **TURN THE 12MM ADJUSTER NUT CW** to reduce cable tension, which will relax the throw out and decrease the installed gap in the clutch – this will **INCREASE FREE PLAY GAIN**.
- **TURN THE 12MM ADJUSTER NUT CCW** to increase cable tension, which will push the throw out into the pressure plate and increase the installed gap in the clutch – this will **REDUCE FREE PLAY GAIN**.

OPTIMIZING EXP ENGAGEMENT

For best performance, engine idle speed should be adjusted to match the EXP engagement setting.

NOTE: Make sure Free Play Gain is optimal before adjusting idle speed.

With a correctly set installed gap and the bike in gear, the bike should move forward under slight opening of the throttle. If not, one of the following symptoms is likely:

- **HIGH IDLE** – the bike moves forward with the throttle fully closed. Solution: reduce idle RPM.
- **LOW IDLE** – the bike moves forward after engine RPM becomes noticeably higher than idle RPM. Solution: increase idle RPM.

NEED ADDITIONAL HELP?

Website

www.rekluse.com/support

Frequently asked questions

www.rekluse.com/faq

Support Videos

www.rekluse.com/support/videos

Phone

(208) 426-0659

Technical Support

Contact Technical Support for questions related to product installation, tuning, and performance.

Hours:

Monday thru Friday: 8:00 a.m. - 5:00 p.m.

Mountain Time zone

Email: tech@rekluse.com

Customer Service

Contact Customer Service for additional product information, orders, and returns.

Hours:

Monday thru Friday: 8:00 a.m. - 5:00 p.m.

Mountain Time zone

Email: customerservice@rekluse.com

