



# **INSTALLATION GUIDE**

Clutch Basket Kit  
For 2006+ KX450

Doc ID: 195-4145A  
Doc Rev: 121322

©2022 Rekluse Motor Sports Inc.  
Rekluse Motor Sports, Inc.  
[customerservice@rekluse.com](mailto:customerservice@rekluse.com)

# **TABLE OF CONTENTS**

|                                  |    |
|----------------------------------|----|
| INSTALLATION NOTES .....         | 2  |
| TOOLS NEEDED .....               | 3  |
| INCLUDED PARTS .....             | 3  |
| DISASSEMBLY .....                | 4  |
| ASSEMBLY OVERVIEW .....          | 6  |
| ASSEMBLE THE BASKET .....        | 6  |
| INSPECTION AND MAINTENANCE ..... | 12 |
| NEED ADDITIONAL HELP? .....      | 14 |

## **INSTALLATION NOTES**

- The machined teeth in the center of your Rekluse billet clutch basket accepts the OEM starter gear.

Your Rekluse basket may have a different tooth profile than your OEM basket, which is part of the intended design for function and manufacturability. They may look different, but your starter gear will fit into the new basket in the same manner that it fit in the OEM basket.

- It is imperative to follow the heating and cooling methods described in the “Starter Gear Installation” section of this document. This ensures a secure press-fit that will prevent the starter gear from backing out of the basket during use.

**Before attempting to install the starter gear**, read through the entire process and be prepared to perform the procedure as quickly as possible at favorable temperatures.

- Always wear gloves and proper eye protection when working on your bike.

## **TOOLS NEEDED**

- Kitchen oven (or toaster oven) & freezer
- Center punch
- Hammer
- Soft mallet or dead blow
- Drill press or power drill
- Shop press or vice
- ¼” bit driver
- Torque wrench (in-lb or N-m)

## **INCLUDED PARTS**

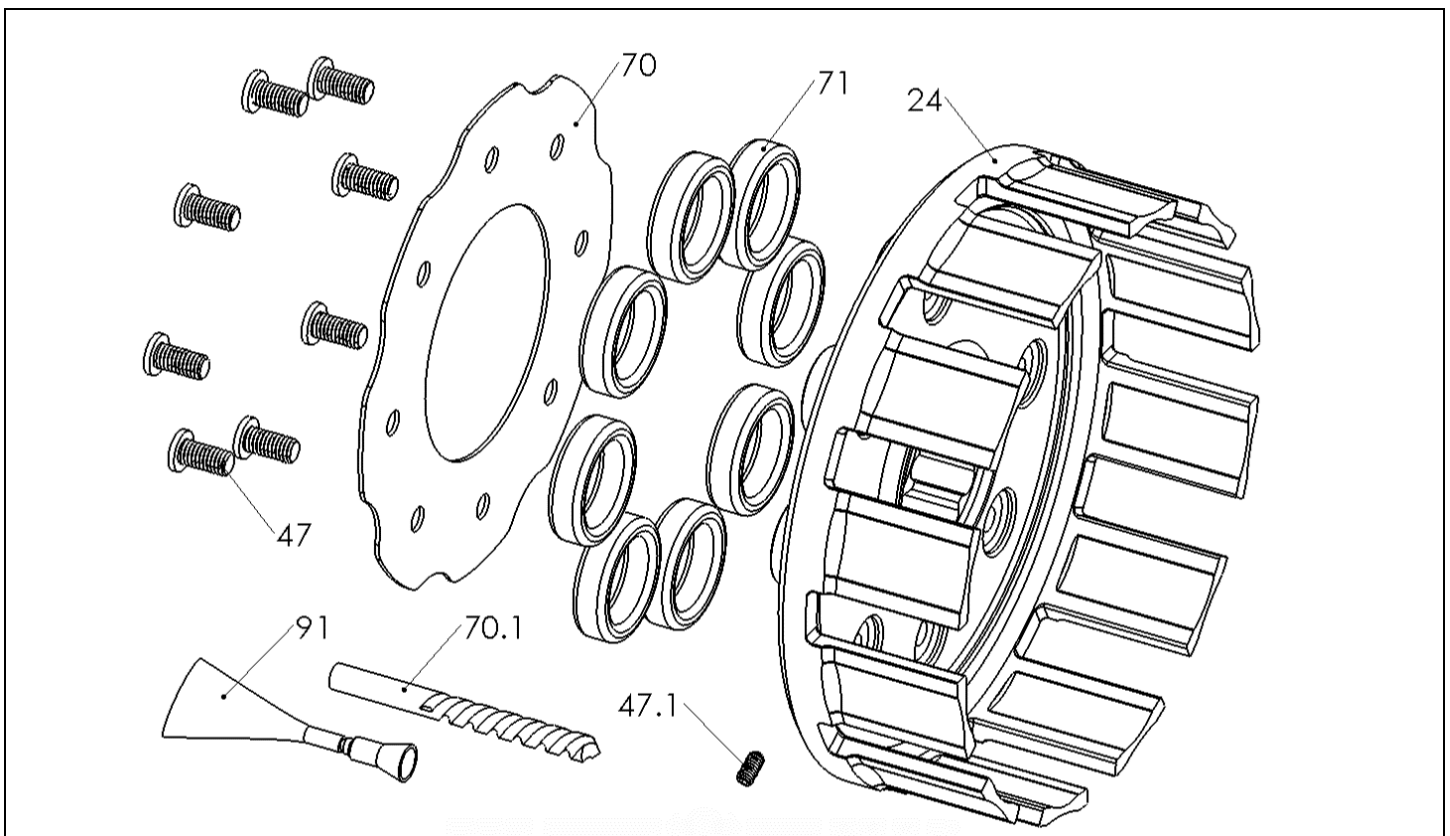

| Item # | Item Type           | Qty |
|--------|---------------------|-----|
| 24     | Clutch basket       | 1   |
| 47     | M6 Flat-head screws | 8   |
| 47.1   | Set screw           | 1   |
| 70     | Backing plate       | 1   |
| 70.1   | ¼” drill bit        | 1   |
| 71     | Basket dampers      | 8   |
| 91     | Loctite 262 (Red)   | 1   |

# **DISASSEMBLY**

1. Lay the bike on its left side. Catch any fuel that might drain with a suitable container. Remove the clutch cover.



2. Remove the existing clutch basket from the engine according to your OE service manual.
3. Set the OE basket on a hard surface with the ring gear facing up. Using a center punch and hammer, punch a divot into the center of each top rivet head.

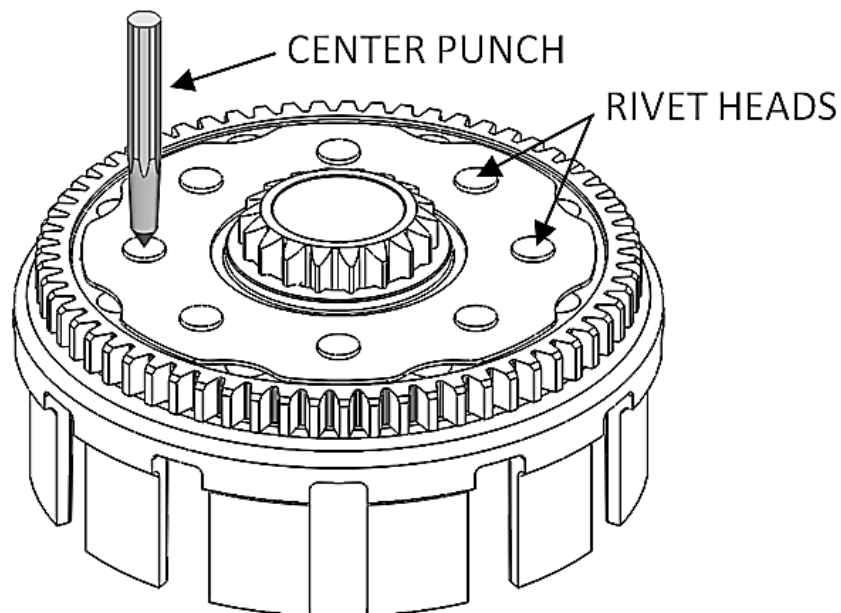

4. Using the supplied drill bit, drill out the heads of all the rivets. Set your drill to 300-400 RPM and use proper cutting fluid or oil for best results.

## **⚠ CAUTION**

**Drill only deep enough to pop the rivet head off. Do not damage the steel ring gear; it will be reused.**

5. Carefully pry the OE steel backing plate from the basket.  
*A hammer and chisel may be used to carefully remove the rivet head if there is some remaining.*

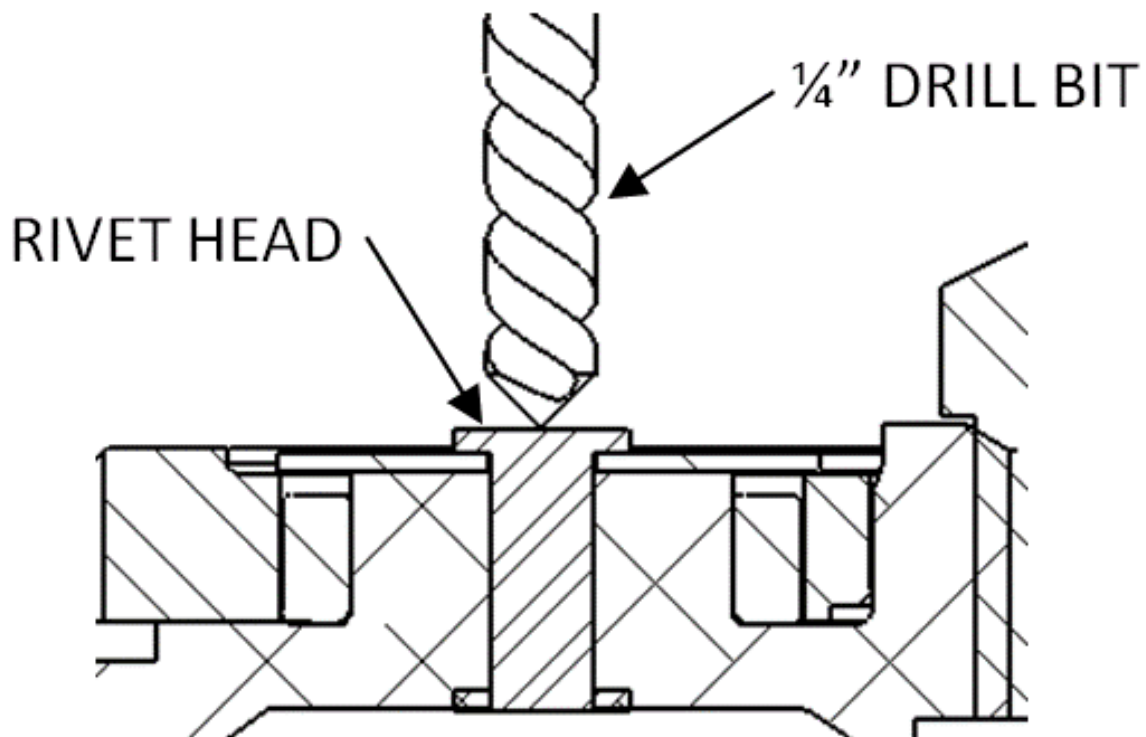

6. Mark the topside of the ring gear, then remove the ring gear.

**Note:** *It is important that the ring gear be reinstalled with the same side facing up. Marking the top side of the ring gear will help ensure that the correct side is facing up during reinstallation.*

7. Press the starter gear out of the OE basket without damaging it.

# ASSEMBLY OVERVIEW

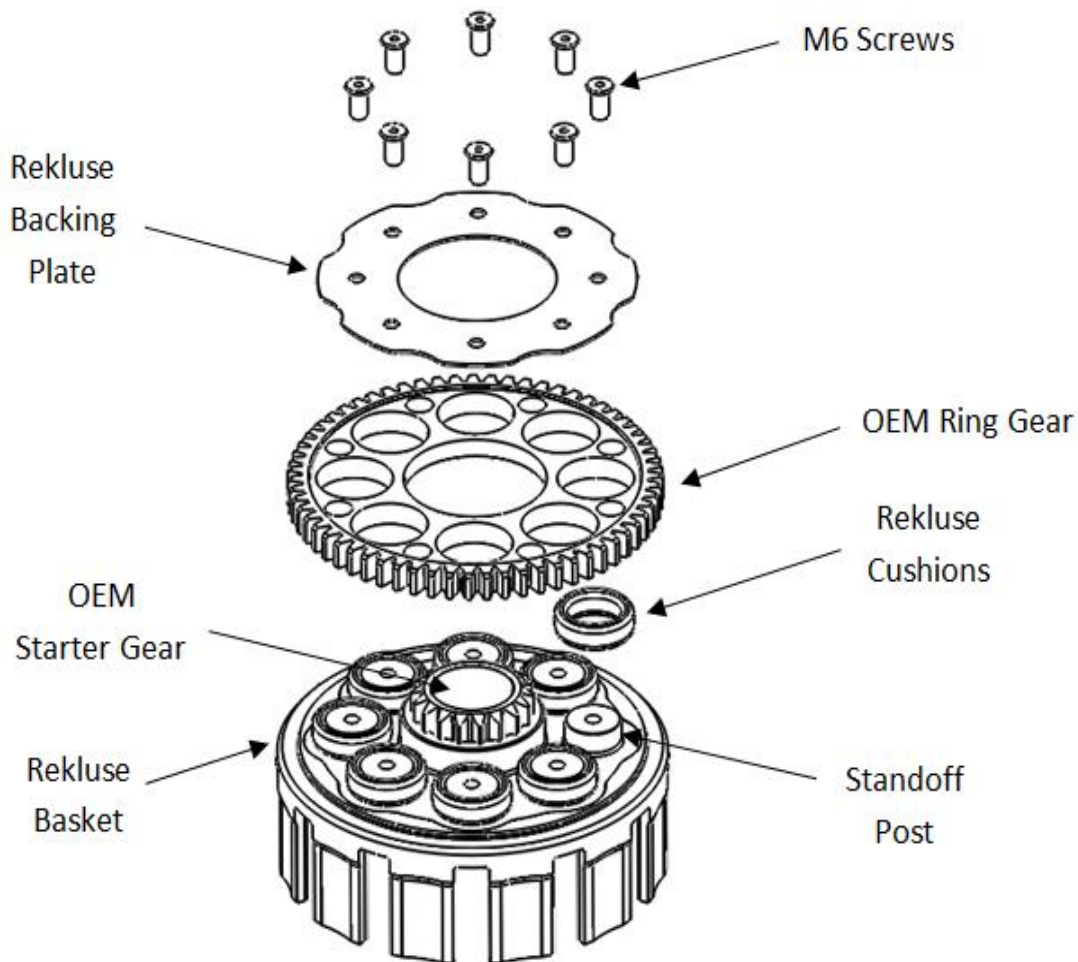

## ASSEMBLE THE BASKET

**Note:** Read through this entire process and prepare your tools so the procedure can be performed as quickly as possible while temperatures are favorable.

1. Place the Rekluse basket in a preheated oven at 400°F (200°C) for 15 minutes, making sure there is no oil on the basket. Place the starter gear in the freezer for the same duration.

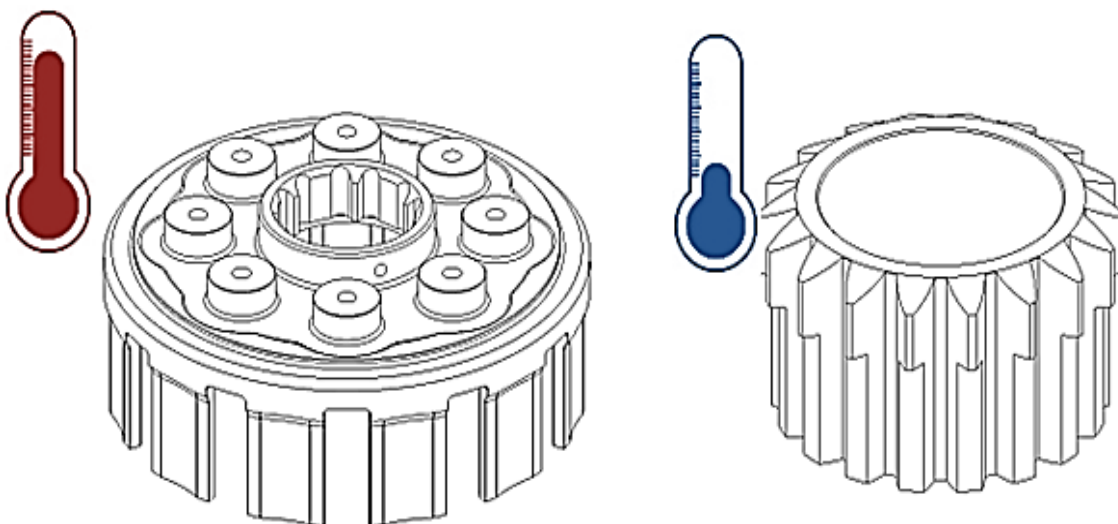

2. After 15 minutes, use oven mitts to remove the basket from the oven, then remove the starter gear from the freezer.

**⚠ CAUTION**

**The basket will be HOT! Be sure to wear protective covering on your hands when removing the basket from the oven.**

3. Set the basket on a flat surface. Quickly align and press the frozen starter gear by hand into the center hole in the basket being careful not to touch the hot basket.

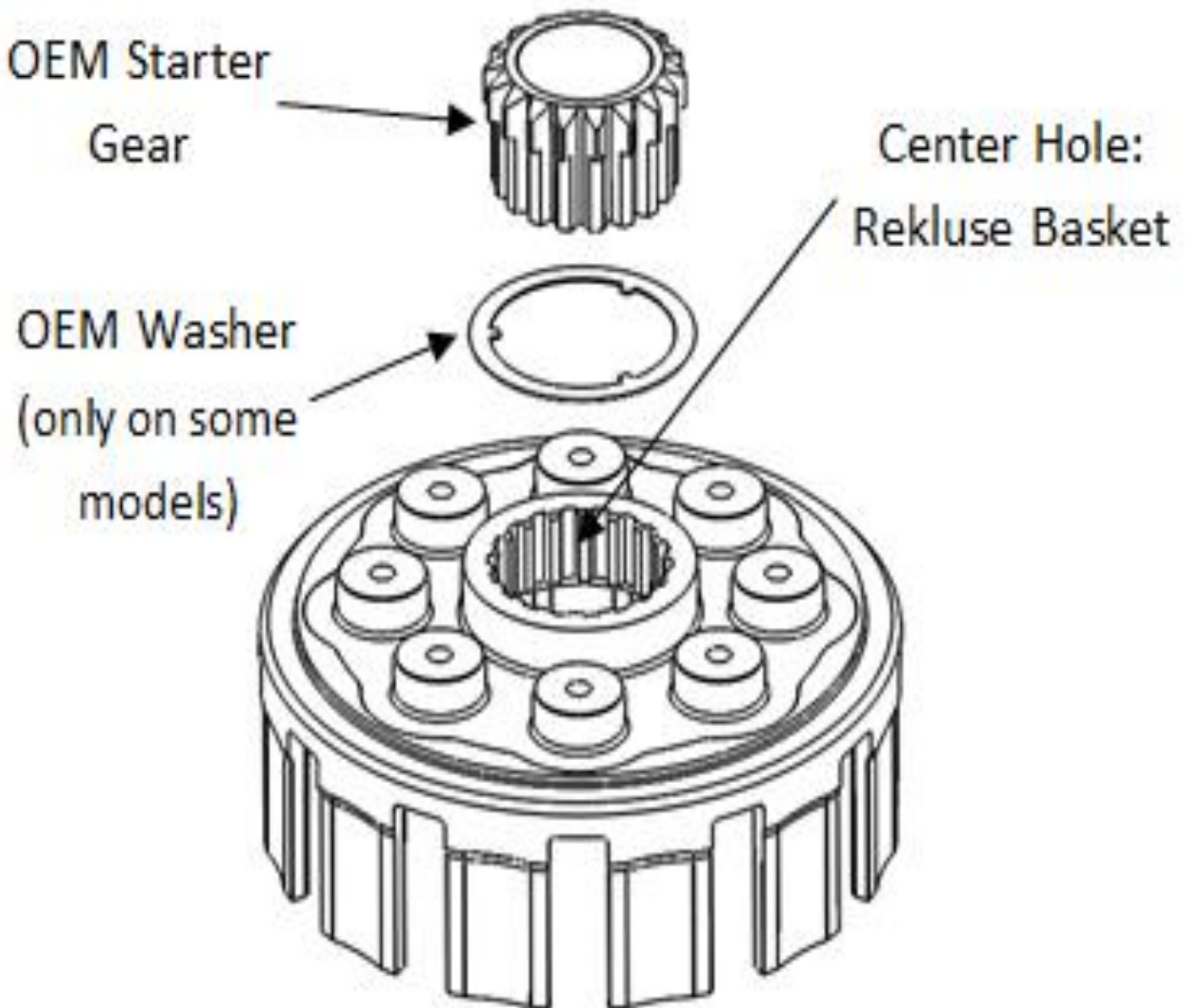

4. If the fit seems too tight, a rubber mallet may be used to tap the gear in while supporting it (such as supporting the basket using a block of wood) or use a shop press or vice. **Tapping the gear in while the tangs are resting on a hard surface may damage the basket.**

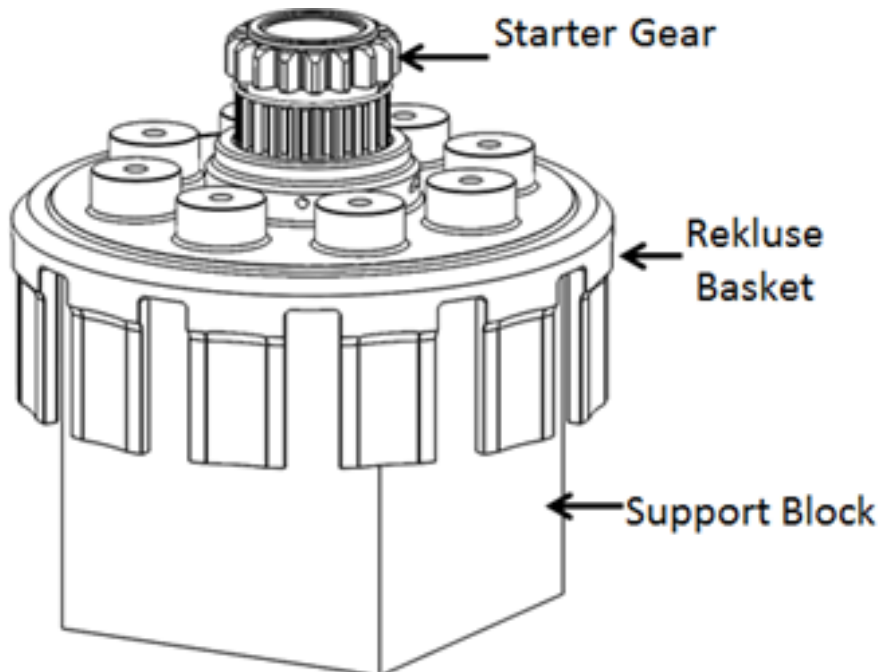

5. Once the basket has cooled, add some of the included red Loctite® 262 on the threads of the set screw, then install the set screw. Torque to **18 in-lb (2 N-m)**.

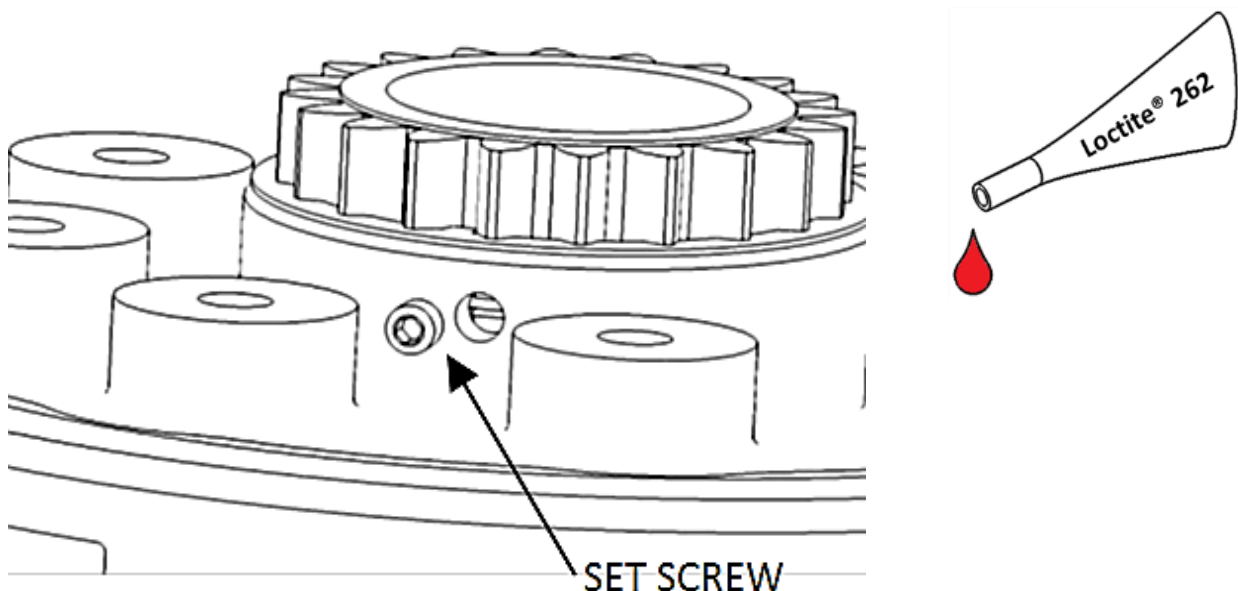



6. Once the basket has cooled, add some engine oil to the damper cushions and install one per standoff post.

**⚠ CAUTION**

Failure to install D-shaped dampers in the correct orientation can result in excessive clutch and transmission wear. Dampers should be oriented as shown in the image below.

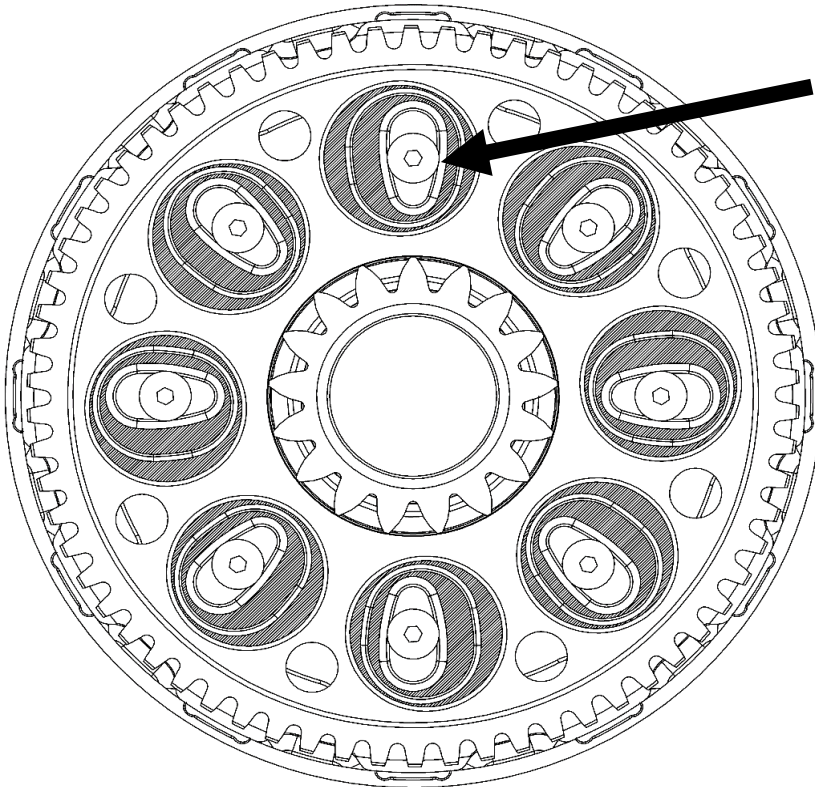

Starting from the top install dampers with the thick side of the damper to left of the standoff

**NOTE:** If the included basket dampers are circular on the inside and not a D shape, orientation does not matter, install and proceed.

7. Reinstall the OE ring gear with the marked side facing up. The ring gear may fit snugly and will likely require using a soft mallet to tap it on until it seats down against the basket.

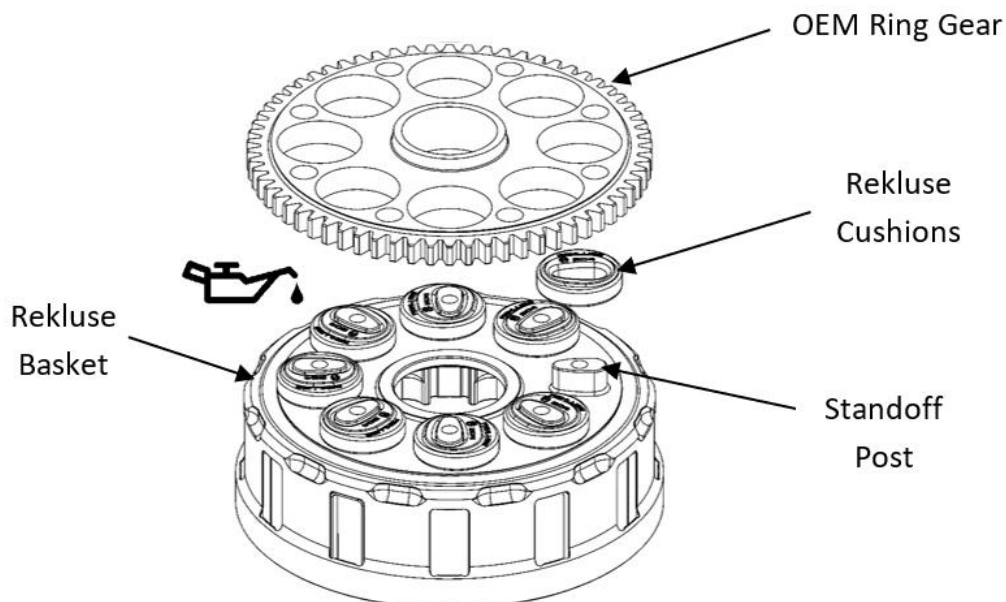

8. Install the Rekluse backing plate and **apply the supplied Loctite® 262 to each of the M6 screws**, threading them into the clutch basket assembly.

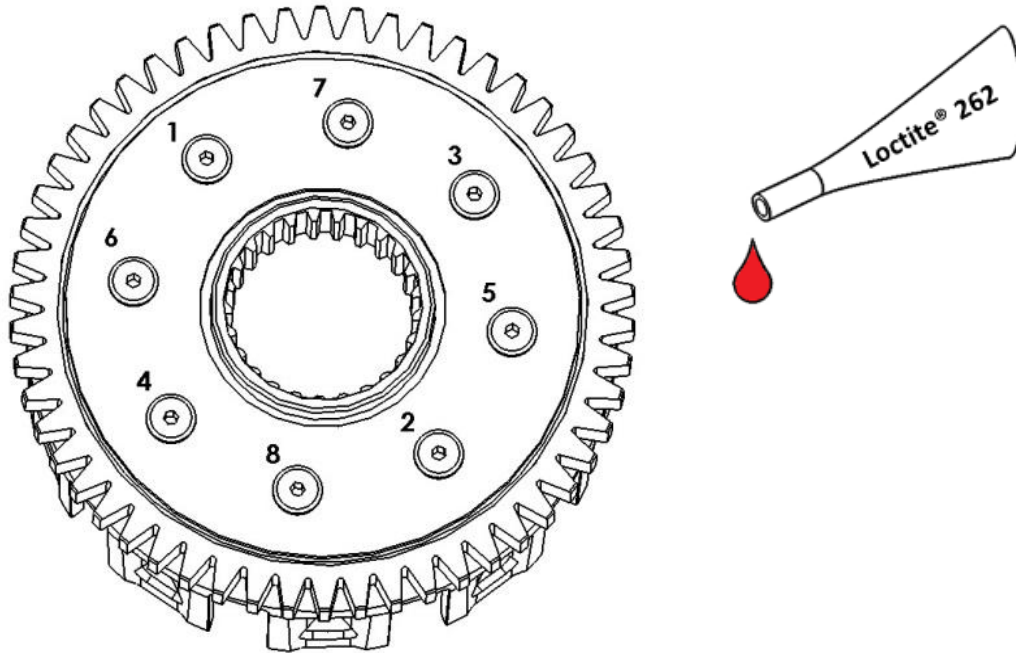

**⚠ WARNING**

**It is critical that you apply Loctite and torque the screws or they can back out during use. Rekluse is not responsible for engine damage caused by screws that back out.**

9. Torque the screw in small increments in a star pattern to **80 in-lbs (9 N-m)** to compress the assembly evenly.

10. Using a hammer and center punch, peen the ends of the screws where they come through the bottom-inside of the clutch basket. Be sure to peen only the screws. **DO NOT peen the aluminum basket.**

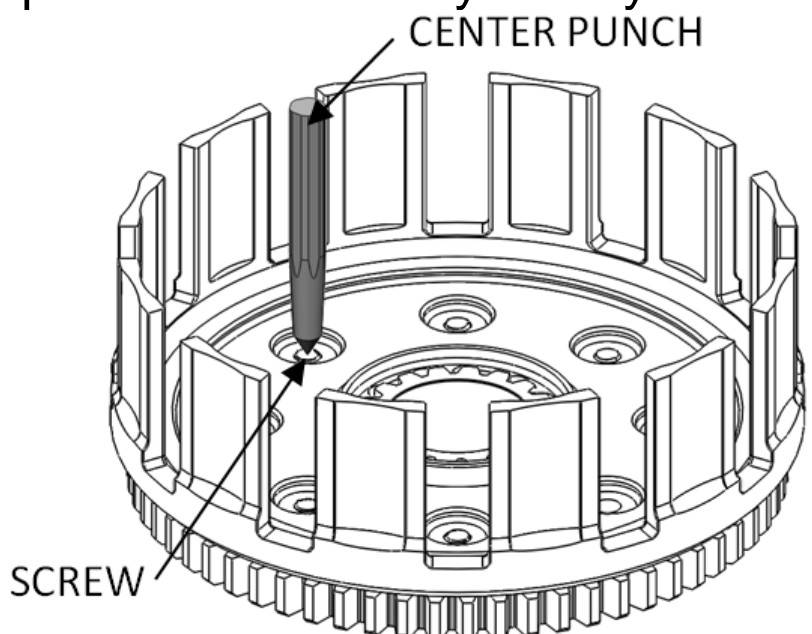

11. Install the new Rekluse clutch basket assembly into the bike by indexing it onto the first engine gear, then rotate the basket to seat the second gear. *The basket will “drop” into place when the basket seats on the second gear.*

**⚠ CAUTION**

The basket must be correctly index on BOTH gears. When the basket is indexed correctly:

A) The basket bushing sits flush with the starter gear.

AND

B) The splined thrust washer will rotate freely below the splines on the main shaft.

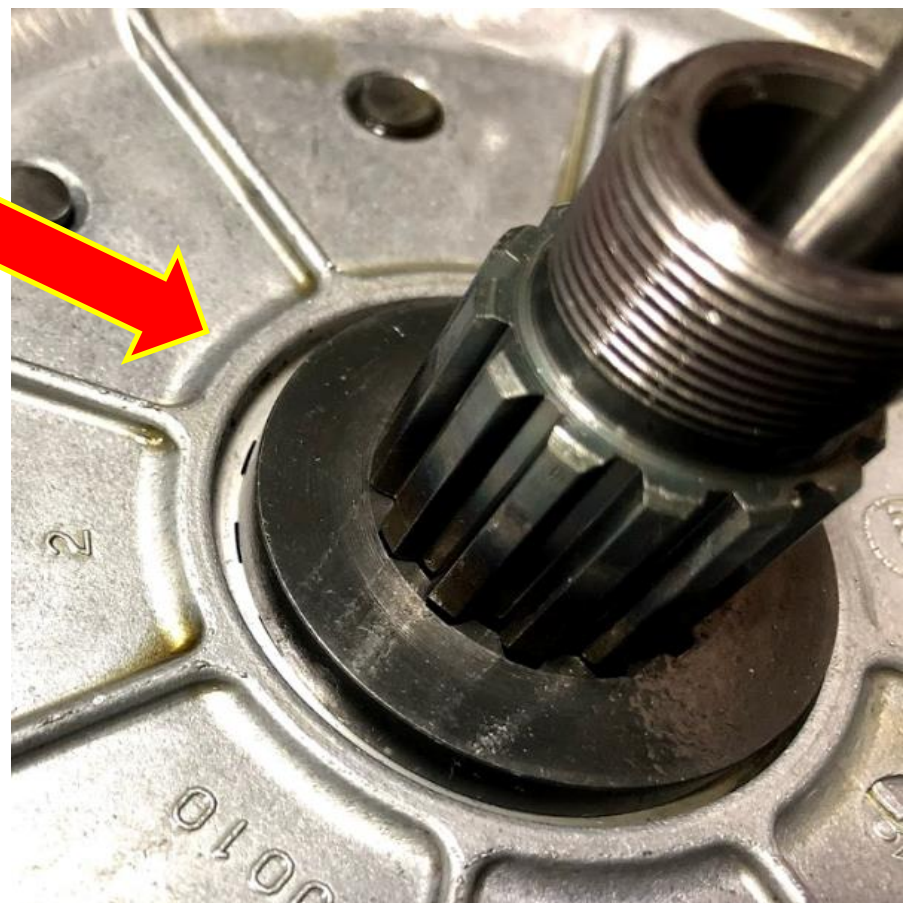

12. Once the basket is indexed correctly, continue to reinstall the clutch following the procedures in your OE service manual.

## **INSPECTION AND MAINTENANCE**

### **Dampers**

The dampers inside the basket assembly shrink due to heat and use. This is a normal wear item and should be **inspected every 10 hours**. Any movement of the dampers will shorten the life of your inner hub and accelerate basket wear.

- Inspect the basket dampers and/or springs by checking the play between the ring gear and the basket. Replace the dampers/springs if you feel any play in the assembly.
- Inspect the dampers if your inner hub is notched. This is usually a sign that the dampers need to be replaced.

### **To inspect the dampers:**

Remove the basket from the engine, hold the ring gear in one hand and the basket in the other, then twist in opposite directions. *The rotational play is sometimes accompanied by an audible “click” sound when rotating back and forth.*

1. If any rotational play can be felt between the basket and the ring gear, the dampers are worn and either the dampers and/or basket assembly need to be replaced.

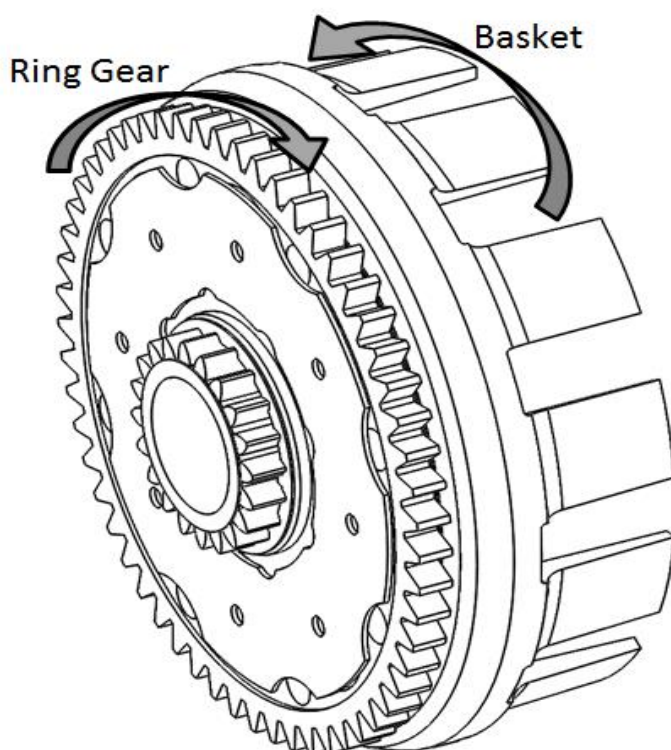

## Basket

Rekluse baskets are built using high quality materials but do wear based on the rider's use, type of terrain, and natural wear and tear.

- To keep your clutch basket performing at its best, perform regular maintenance on your bike and inspect your components regularly.
- Inspect the clutch basket for notching. Notched basket tang faces can cause performance issues. The basket should also be inspected for any fatigue cracking at the tang bases. Replace basket if necessary.
- Do not use baskets that have been filed, machined, or modified on the tangs.

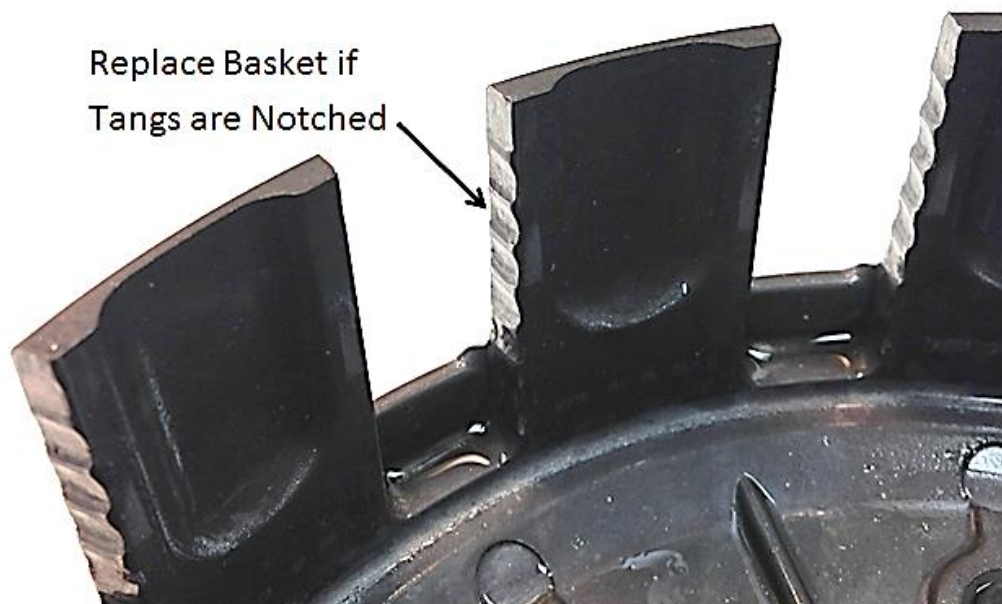

## Starter Gear

The starter gear fitment can wear and should be inspected at regular intervals. A loose starter gear can cause performance issues in the clutch.

### To inspect the starter gear:

1. Press on one side of the clutch basket, then press on the opposite side trying to see if the basket moves when pressure is applied to each side.
2. If the basket moves or tilts significantly, the basket needs to be replaced.

# **NEED ADDITIONAL HELP?**

## **Website**

[www.rekluse.com/support](http://www.rekluse.com/support)

## **Frequently Asked Questions**

[www.rekluse.com/faq](http://www.rekluse.com/faq)

## **Support Videos**

[www.rekluse.com/support/videos](http://www.rekluse.com/support/videos)

## **Phone**

(208) 426-0659

## **Technical Support**

Contact Technical Support for questions related to product installation, tuning, and performance.

### **Hours:**

Monday thru Friday: 8:00 a.m. - 5:00 p.m.

Mountain Time zone

Email: [tech@rekluse.com](mailto:tech@rekluse.com)

## **Customer Service**

Contact Customer Service for additional product information, orders, and returns.

### **Hours:**

Monday thru Friday: 8:00 a.m. - 5:00 p.m.

Mountain Time zone

Email: [customerservice@rekluse.com](mailto:customerservice@rekluse.com)

