



**REKLUSE**<sup>®</sup>  
**clutchbasket**

## **REKLUSE MOTOR SPORTS**

---

The Rekluse Clutch Basket Kit

# **INSTALLATION GUIDE**

Doc ID: 195-4130A  
Doc Rev: 121322

## **TOOLS NEEDED**

- Center punch
- Hammer
- Drill dress or drill
- 1/4" driver
- Torque wrench (in-lb or N-m)

©2012 Rekluse Motor Sports  
Rekluse Motor Sports, Inc.  
[customerservice@rekluse.com](mailto:customerservice@rekluse.com)

# INCLUDED PARTS

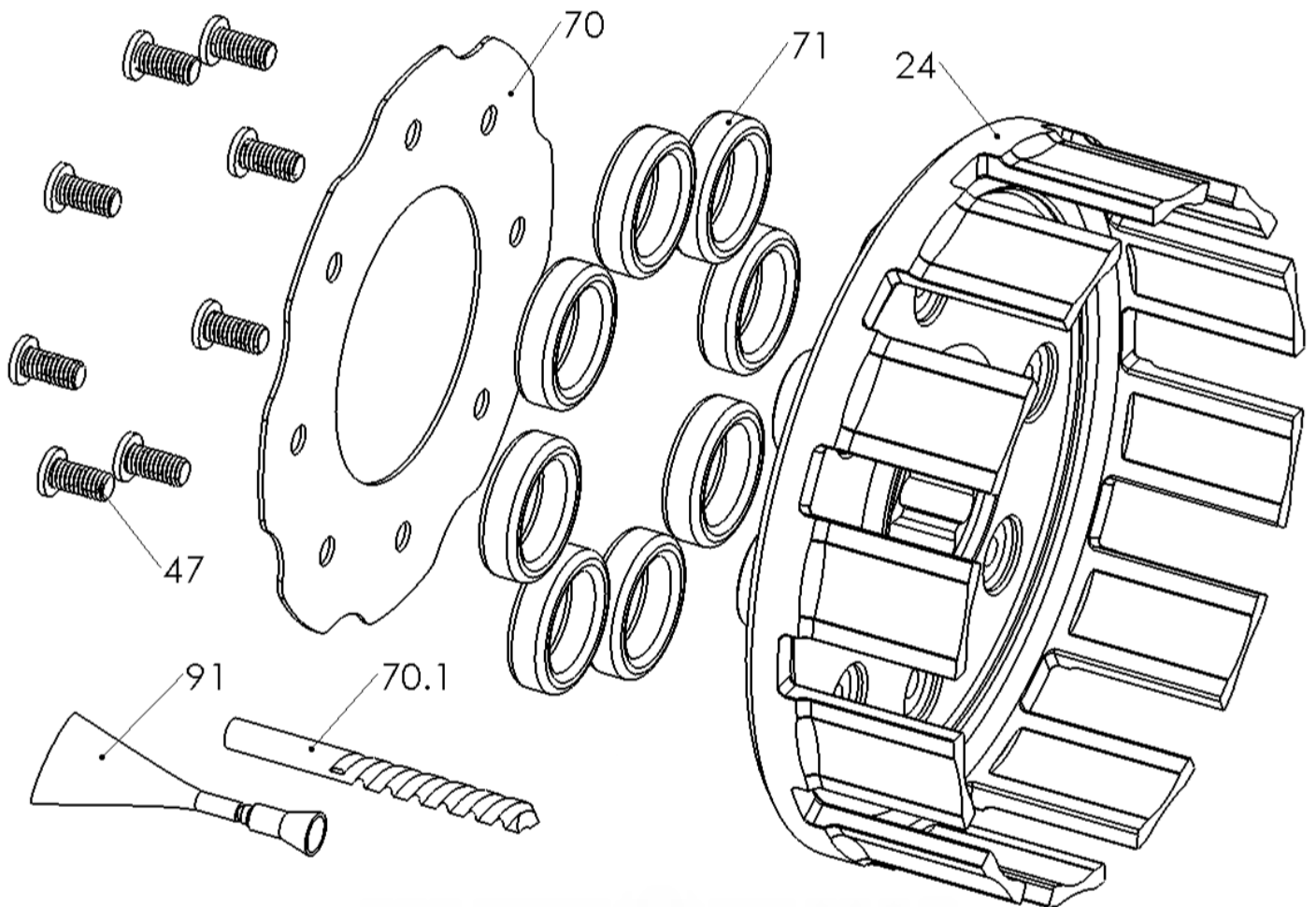

Item	Item Type	Qty
24	Clutch Basket	1
47	M6 Flat-Head Screws	8*
70	Backing Plate	1
70.1	¼" Drill Bit	1
71	Basket Damper (cushions)	8*
91	Loctite 262 (Red)	1

\*Husqvarna 250F baskets (RMS-4155) uses only 6 dampers and screws.

Visit [Rekluse.com/support](https://Rekluse.com/support) for a full parts fiche illustration and part numbers.

# BASKET OVERVIEW

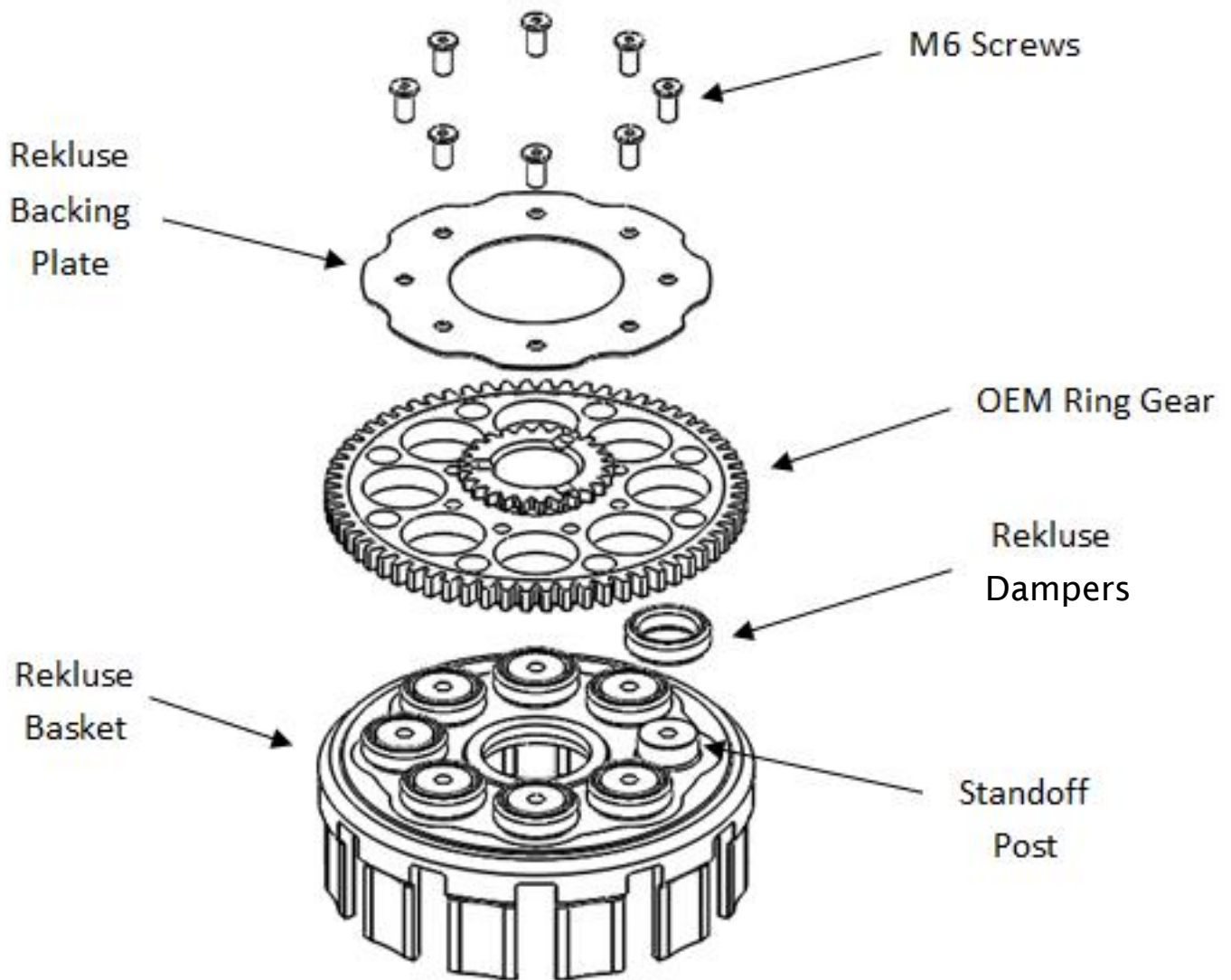

## BIKE PREP & DISASSEMBLY

1. Lay the bike on its left side. Catch any fuel that might drain in a suitable container.
2. Remove the clutch cover.

**NOTE:** Rekluse recommends replacing the case cover gasket after reinstalling the clutch.



3. Following the procedures in your OE service manual, remove the existing clutch basket from the engine.
4. Set the OE basket on a hard surface with the ring gear facing upward. Using a center punch and hammer, punch a divot into the top of each rivet head, taking care to be on center.

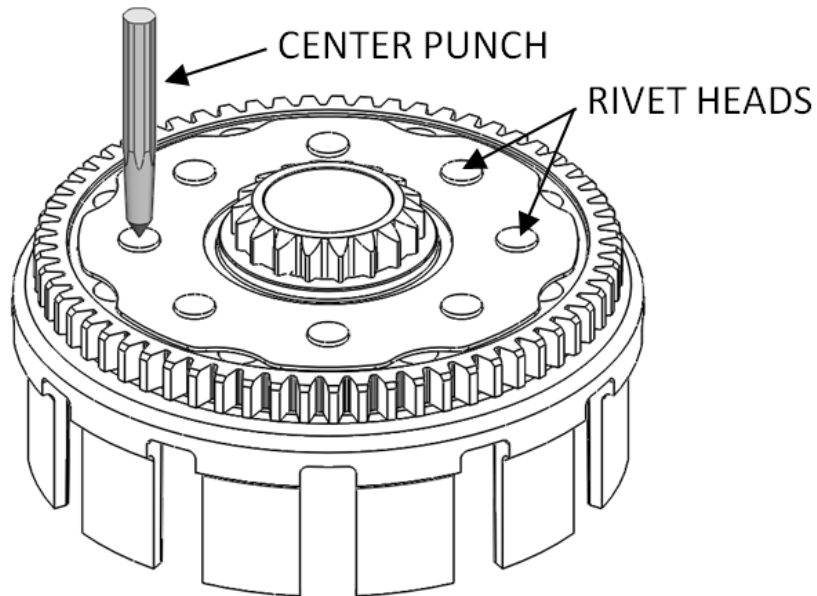

5. Use the supplied drill bit to drill out the heads of all the rivets. Set your drill to 300-400 RPM and use proper cutting fluid or oil for best results.

**CAUTION**

**Drill only deep enough to pop the rivet head off. Do not damage the steel ring gear; it will be reused.**

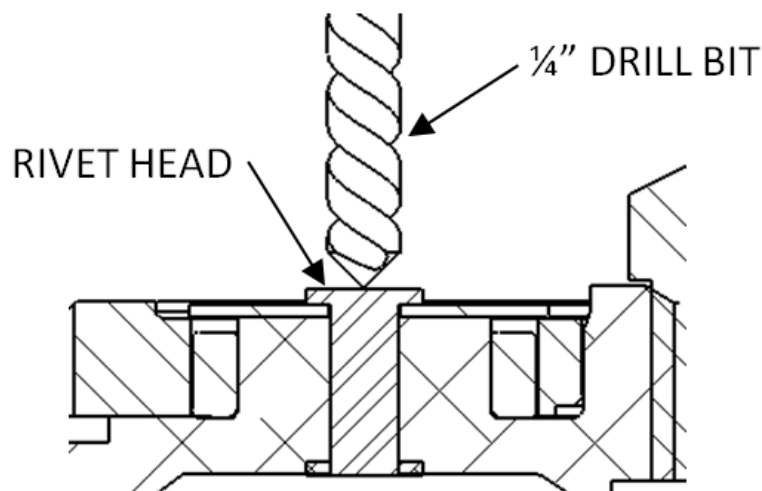

6. Carefully pry the OE backing plate off the basket and remove the OE ring gear.

7. Add some engine oil to the new Rekluse dampers, and install one per standoff post.

**NOTE:** If the included basket dampers are circular on the inside such as the image below, orientation does not matter, install and proceed.

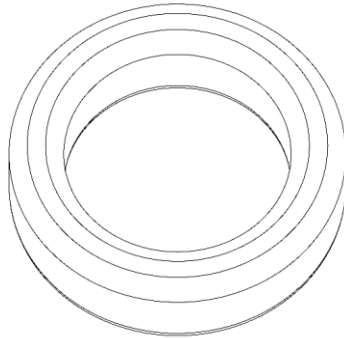

**⚠ CAUTION**

Failure to install dampers in the correct orientation can result in excessive clutch and transmission wear. Dampers should be oriented as shown in the image below.

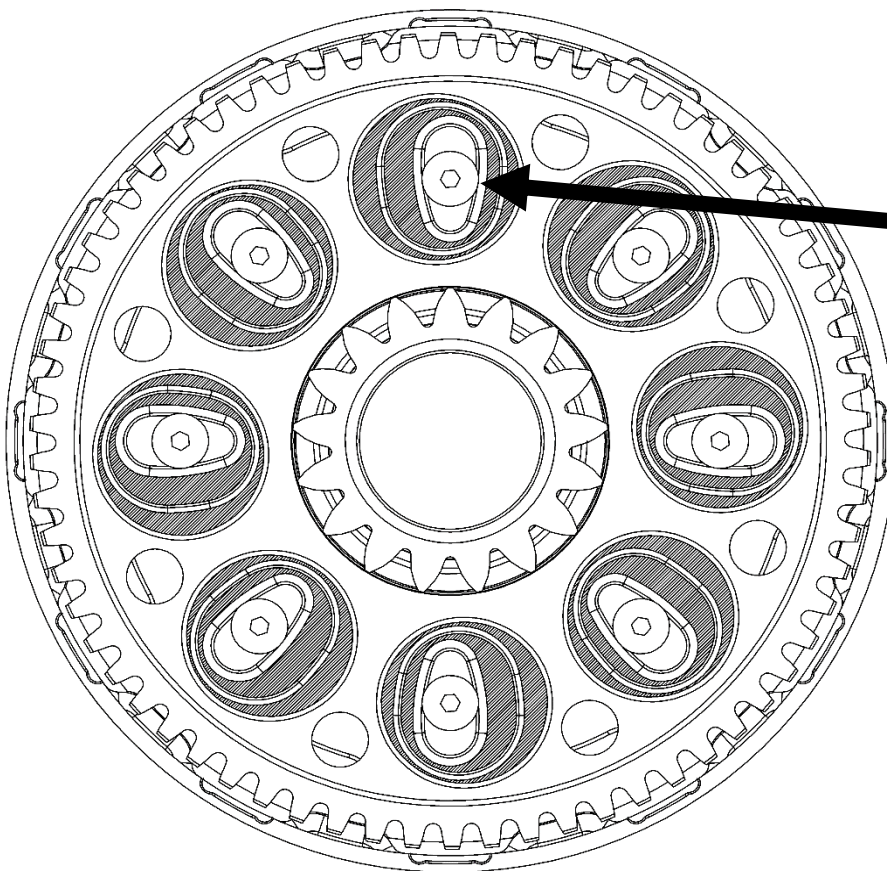

Starting from the top install dampers with the thick side of the damper to left of the standoff

**For RMZ250 '10+ model owners only:**

- Reinstall the OE judder seat followed by the judder spring, cupped side up, after installing the dampers.

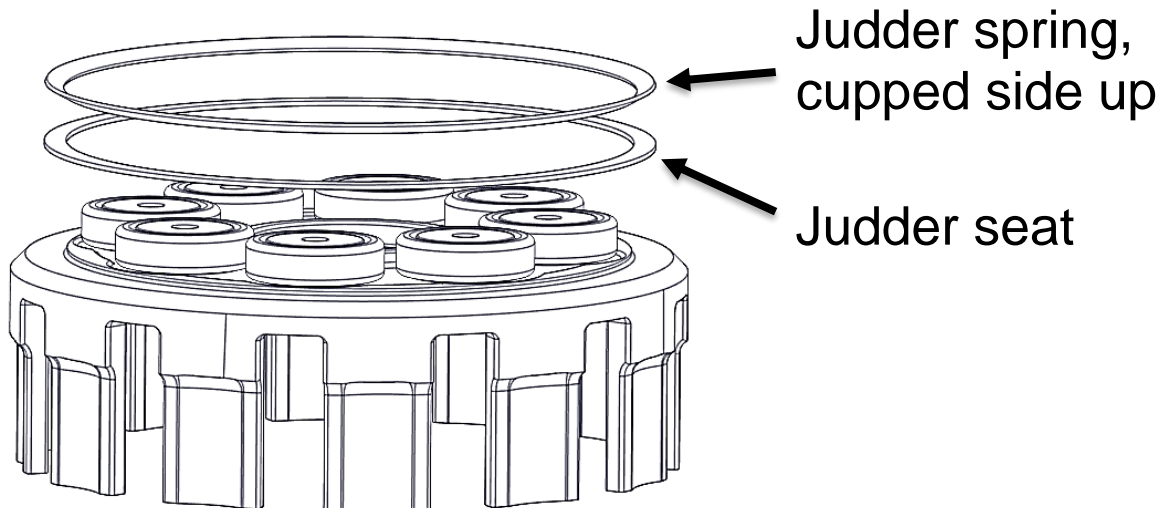

1. Reinstall the OE ring gear. The ring gear may fit snugly and will likely require using a soft mallet to tap it on until it seats all the way against the basket.

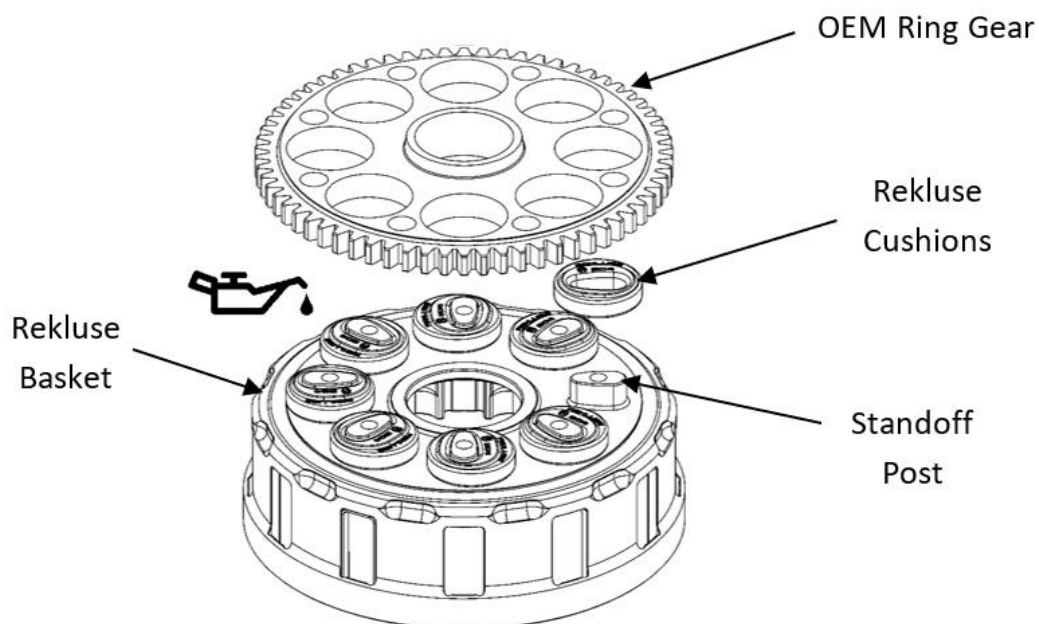

2. Install the Rekluse backing plate, then apply the supplied Loctite 262 to each of the M6 screws before threading them into the clutch basket assembly.

**For RMZ250 '10+ model owners only:**

- Install the backing plate with the rounded collar facing up.

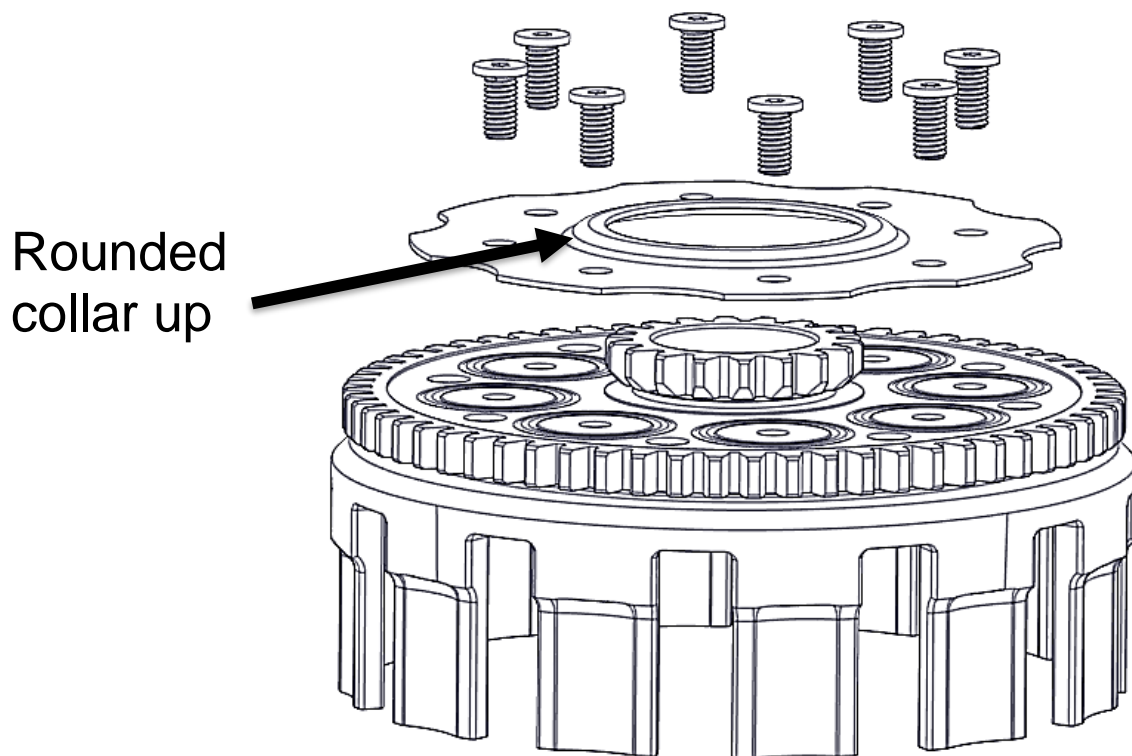

3. Tighten to **80 in-lb (9 N-m)** in a crisscross pattern to compress the assembly evenly.

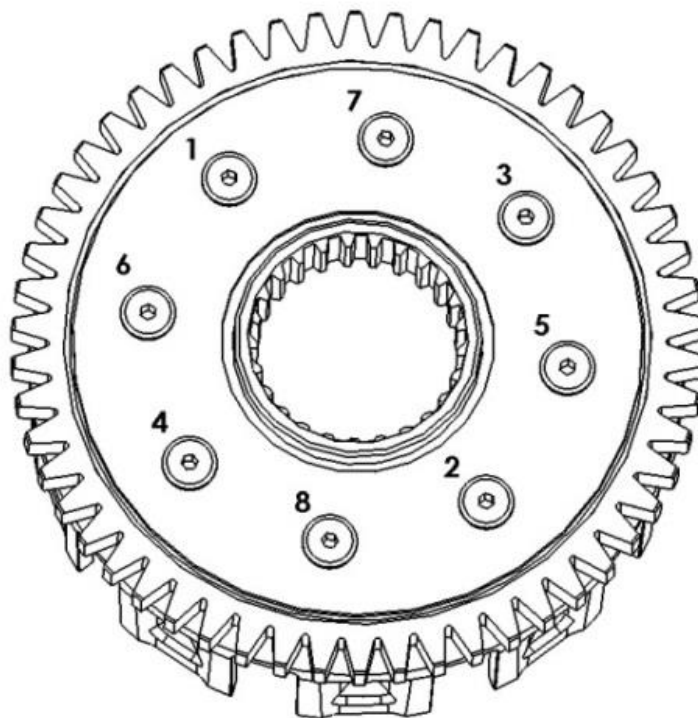

4. Turn the basket over on the workbench.

- Using a hammer and center punch, peen the ends of the screws where they come through the bottom-inside of the clutch basket.

**CAUTION**

Be sure to peen only the screws. **DO NOT** peen the aluminum basket.

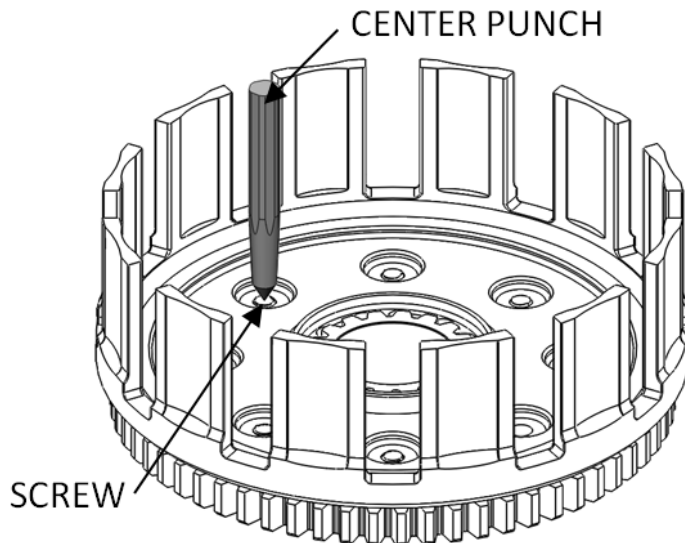

**WARNING**

It is **critical** that you apply Loctite and peen the ends of the screws or they can back out. Rekluse is not responsible for engine damage caused by screws that back out.

- Install the new clutch basket assembly into the engine following the procedures in your OE service manual.



# **INSPECTION AND MAINTENANCE**

## **Basket**

Rekluse baskets are built using high quality materials but do wear based on the rider's use, type of terrain, and natural wear and tear.

- To keep your clutch basket performing at its best, perform regular maintenance on your bike and inspect your components regularly.
- Inspect the clutch basket for notching. Notched basket tang faces can cause performance issues. The basket should also be inspected for any fatigue cracking at the tang bases. Replace basket if necessary.
- Do not use baskets that have been filed, machined, or modified on the tangs.

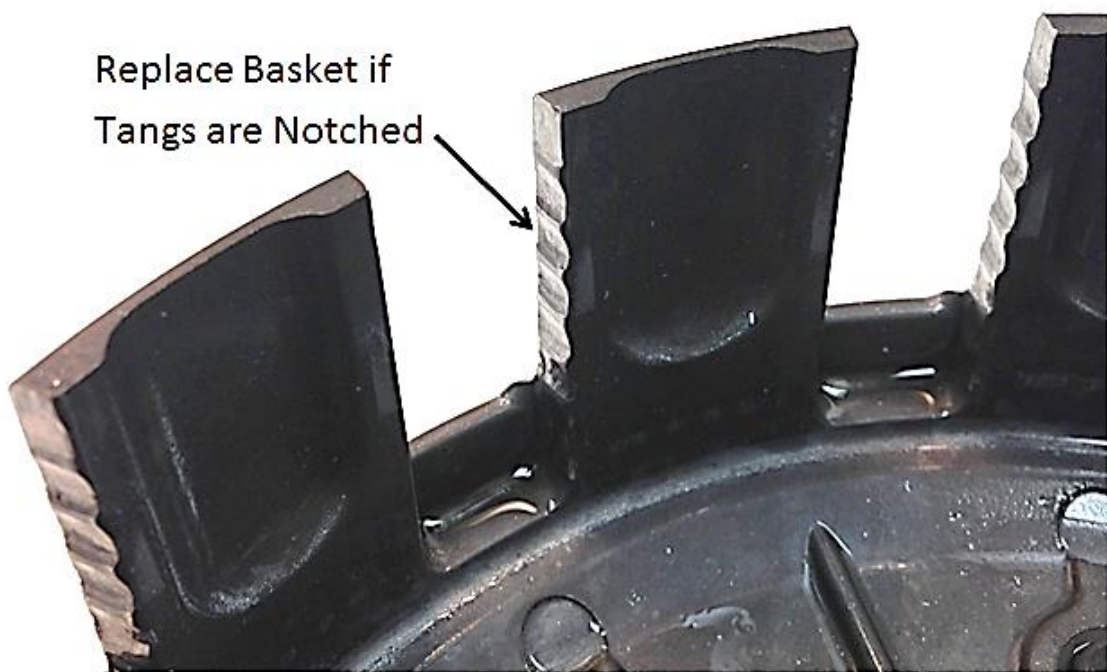

## **Dampers**

The OE dampers inside the center hub assembly shrink due to heat and use. This is a normal wear item and should be inspected periodically. Any movement between the dampers will shorten the life of your inner hub and accelerate basket wear.

- Inspect the basket dampers and/or springs by checking the play between the ring gear and the basket. Replace the dampers/springs if you feel any play in the assembly.
- Inspect the dampers if your inner hub is notched. This is usually a sign that the dampers need to be replaced.

To inspect the dampers:

1. Remove the basket from the engine, hold the ring gear in one hand and the basket in the other, then twist in opposite directions. The rotational play is sometimes accompanied by an audible “click” sound when rotating back and forth.
2. If any rotational play can be felt between the basket and the ring gear, the dampers are worn and either the dampers and/or basket assembly need to be replaced.

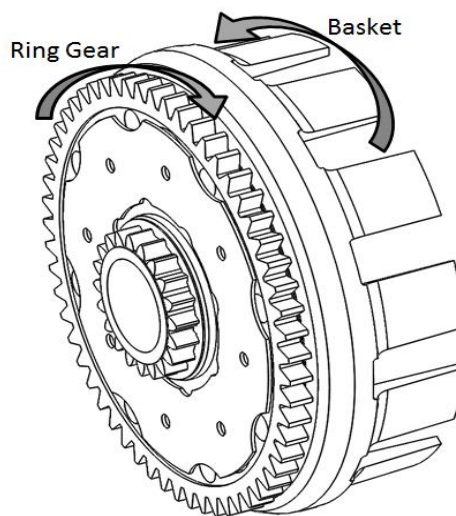

## **Starter Gear**

The starter gear fitment can wear and should be inspected at regular intervals. A loose starter gear can cause performance issues in the clutch.

To inspect the starter gear:

1. Press on one side of the clutch basket, then press on the opposite side trying to see if the basket moves when pressure is applied to each side.
2. If the basket moves or tilts significantly, the basket needs to be replaced.

## **NEED ADDITIONAL HELP?**

Contact Technical Support for questions related to product installation.

Technical Support hours:

Monday thru Friday: 8:00 a.m. - 5:00 p.m.

Mountain Time zone

Phone: (208) 426-0659

Email: [tech@rekluse.com](mailto:tech@rekluse.com)