



INSTALLATION & USER'S GUIDE

Indian Scout
TorqDrive® Clutch

Doc ID: 191-2831A
Revision: 040819

Table of Contents

OVERVIEW	2
INSTALLATION TIPS	3
TOOLS.....	3
INCLUDED PARTS	4
BEFORE YOU BEGIN.....	5
PREPARE BIKE FOR INSTALLATION.....	5
DISASSEMBLE CLUTCH.....	6
INSTALL THE CLUTCH PACK	9
Notes for Clutch Pack Installation:	10
PRESSURE PLATE INSTALLATION.....	13
CLUTCH COVER INSTALLATION.....	14
FINISH INSTALLATION	17
BREAK-IN.....	18
MAINTENANCE.....	18
Disk inspection examples.....	19
TROUBLESHOOTING	21
Performance issues.....	21
Clutch Drag	21
Clutch Slip	21
NEED ADDITIONAL HELP?.....	22

OVERVIEW

This kit replaces many of the OE (Original Equipment) or “stock” clutch parts with your new Rekluse TorqDrive® clutch parts. The following parts are replaced:





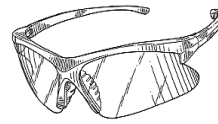

- This kit will replace all the OE frictions and drive plates with a Rekluse TorqDrive® clutch pack.

INSTALLATION TIPS

- Read the separate included Safety Information document before operating the vehicle with the product installed.
- Read this entire document before performing any steps.
- If you install this product for a customer or another person, instruct them to read the **Safety Information** document and the **Installation and User Guide** before operating the bike with the product.
- Protect eyes and skin – wear safety glasses and work gloves.
- Use the torque values listed in the instructions. Otherwise, use the torque specifications found in your OE service manual.
- For optimal clutch performance Rekluse recommends using fresh, clean oil that **meets JASO-MA** oil rating requirements. Rekluse offers Factory Formulated Oil™ developed specifically for Rekluse products. Rekluse Factory Formulated Oil is a perfect complement to any OEM or aftermarket wet clutch. Visit www.rekluse.com to learn more.
- Inspect your OE cable for fraying and replace if needed.



TOOLS

 10 mm			
10 mm socket	Magnet Stick	Metric Wrench	Torque Wrench
			
Pick	Hex key set		

INCLUDED PARTS

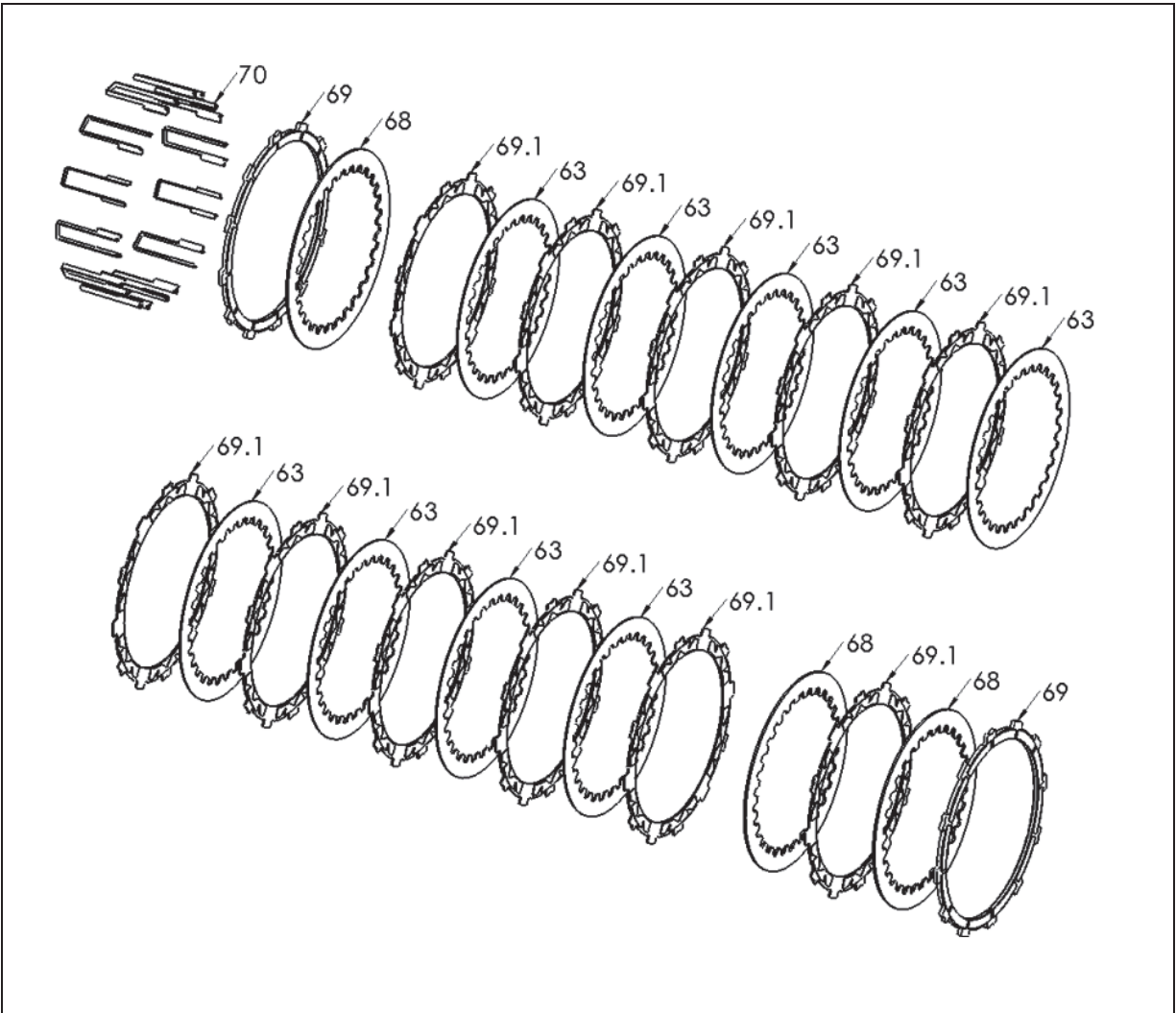

Item	Description	Qty.
63	Steel drive plates - .040 in	9
68	Steel drive plate - .065 in	3
69	TorqDrive® friction disk – Thick .150 in	2
69.1	TorqDrive® friction disks	11
70	Basket sleeves	12

Visit www.rekluse.com/support for a full parts fiche illustration and part numbers.

BEFORE YOU BEGIN

It is necessary to drain the oil from the bike before you can install the Rekluse clutch pack. You can purchase an oil filter and new drain crush washers from an authorized Polaris/Indian dealer.

Part numbers:

- Oil filter #2520799
- Crush washer (2) #5812232

PREPARE BIKE FOR INSTALLATION

1. Stand the bike up on a suitable bike stand.



2. On the underside of the bike, use a hex key to remove the two drain screws and crush washers, then drain the oil into a suitable container.

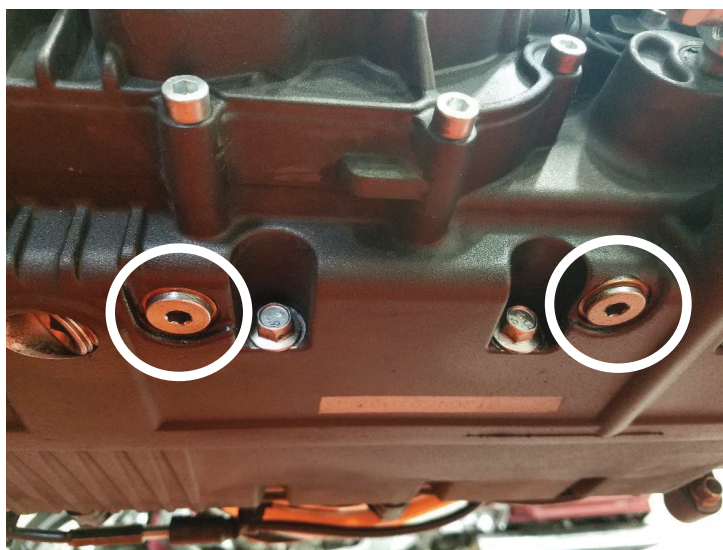

DISASSEMBLE CLUTCH

1. Remove the 2 bolts that hold the clutch cable bracket in place on the side of the engine.

Note: *These are located behind the lower exhaust header pipe. Make note of the position of the clutch actuator arm. It needs to be in this position when reinstalling the clutch cover.*



2. With the bracket loose, remove the cable end from the clevis of the clutch actuator arm.



3. Remove the 13 clutch cover bolts followed by the clutch cover.

Note: This may require loosening bolts (at the cylinder head and rear clamp) that hold the lower exhaust header pipe in place.



4. Remove the OE bolts and springs, then remove the pressure plate with the throw-out. Set them aside. They will be reused.

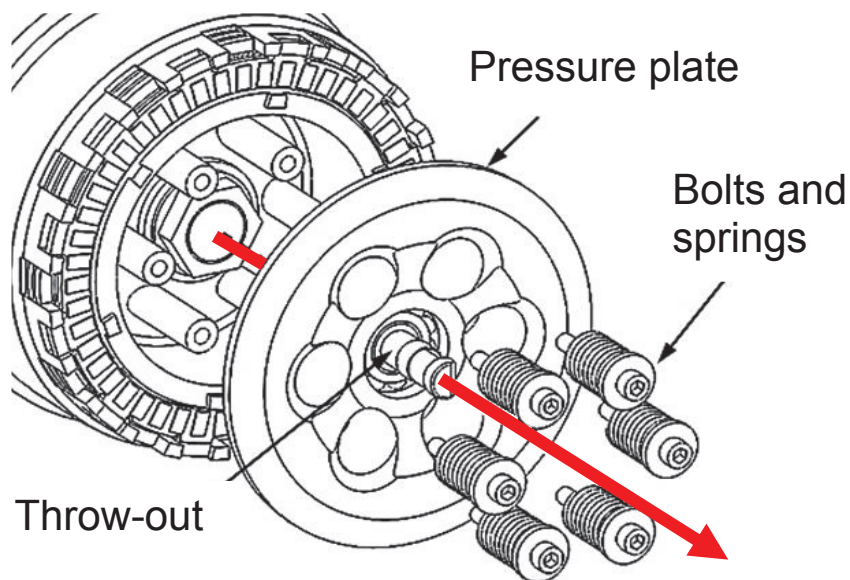

5. Remove the entire OE clutch pack (all the friction and drive plates). They will not be reused.

Note: *It may be necessary to use picks to reach and remove the bottom of the clutch pack. The judder spring and seat can remain in the clutch basket. They will be reused.*

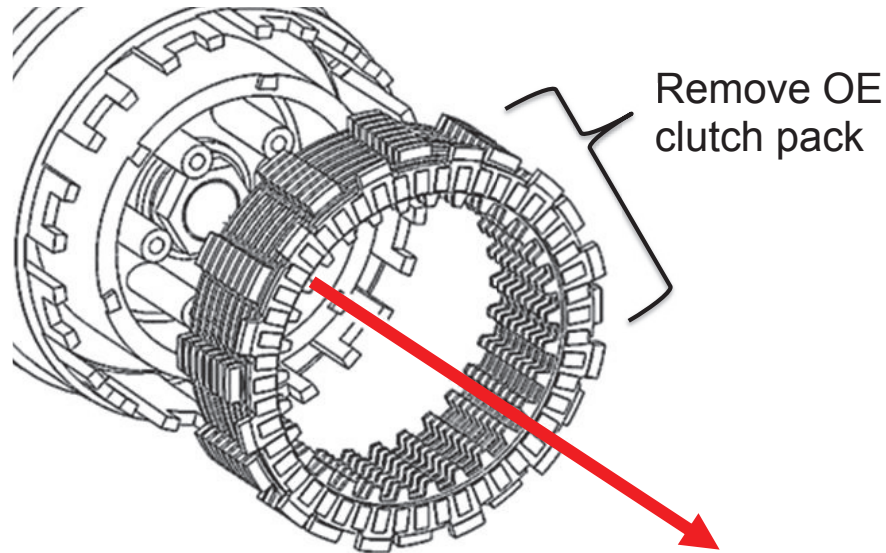

6. Inspect the clutch basket for notching. Do not install sleeves or use product with a notched basket. Notched basket tang faces can cause the sleeves to break. Do not use baskets that have been filed, machined, or modified on the tangs. Replace basket if necessary.

⚠ WARNING

Failure to inspect the basket and replace if necessary could result in death, serious injury, and/or property damage.

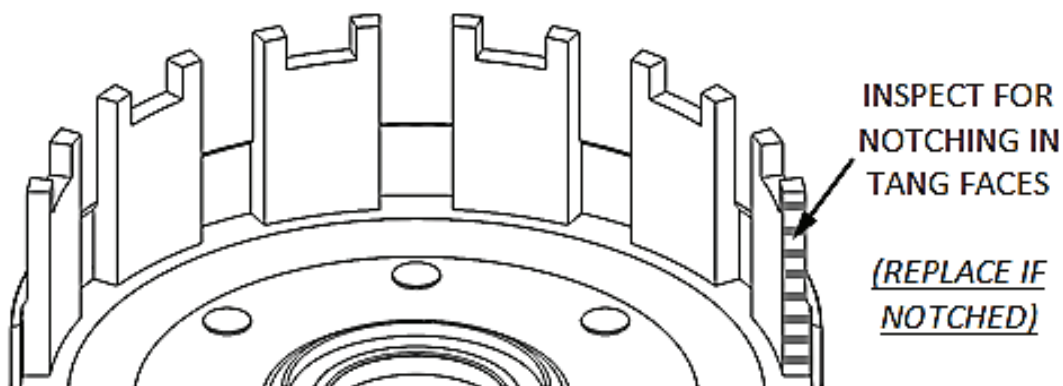

INSTALL THE CLUTCH PACK

1. Soak the friction disks in engine oil for 5 minutes. Make sure the friction disks are coated in oil on both sides.

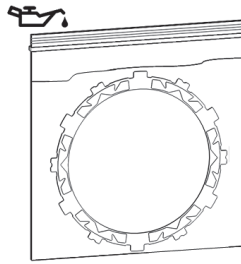

2. Install **ALL** the Rekluse basket sleeves into the basket slots. Make sure the sleeve tabs sit against the inside of the basket, then push the sleeves down until they contact the bottom of the tang slot. See pictures for reference.

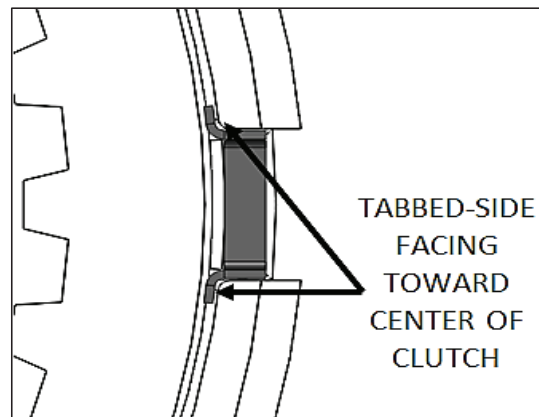
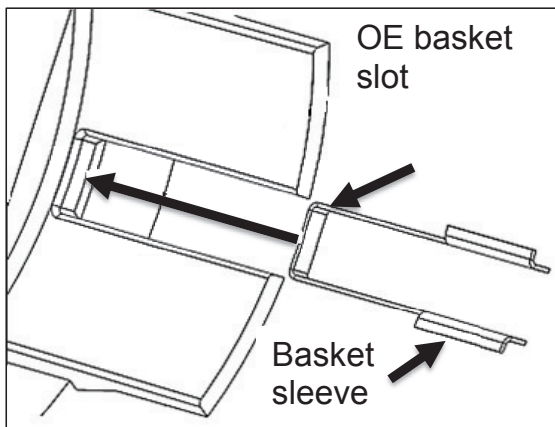

Note: When seated in the basket, the sleeves will stick slightly above flush with the top of the basket. This is normal.

Install all the basket sleeves

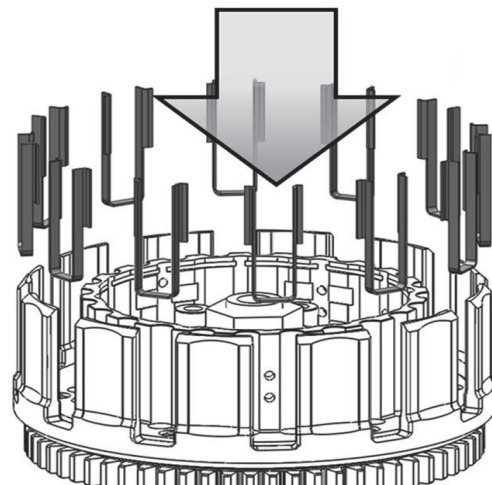

Notes for Clutch Pack Installation:

- *When assembling the clutch pack, it is important to line up the alignment notches on the friction disk tabs. Correct alignment is critical for optimal performance.*
- *Some friction disks are marked with a small colored dot. This mark is used for processing and can be ignored.*

Align notches of
friction disks

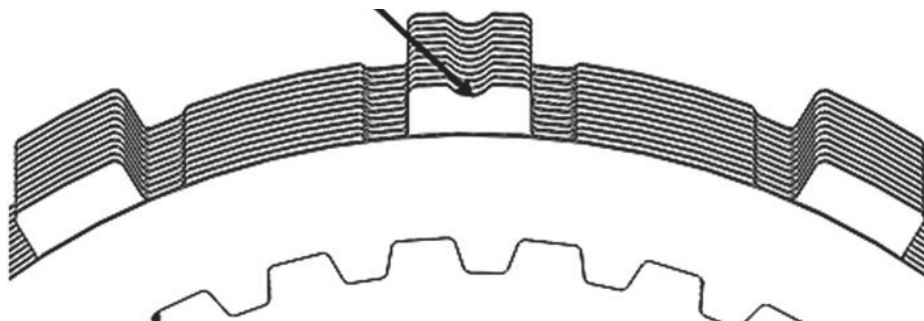

- *Some OE basket have “half slots” at the top of the basket tangs. Rekluse products require the entire clutch pack be installed into the MAIN (deeper) basket slots. See the following picture for reference.*

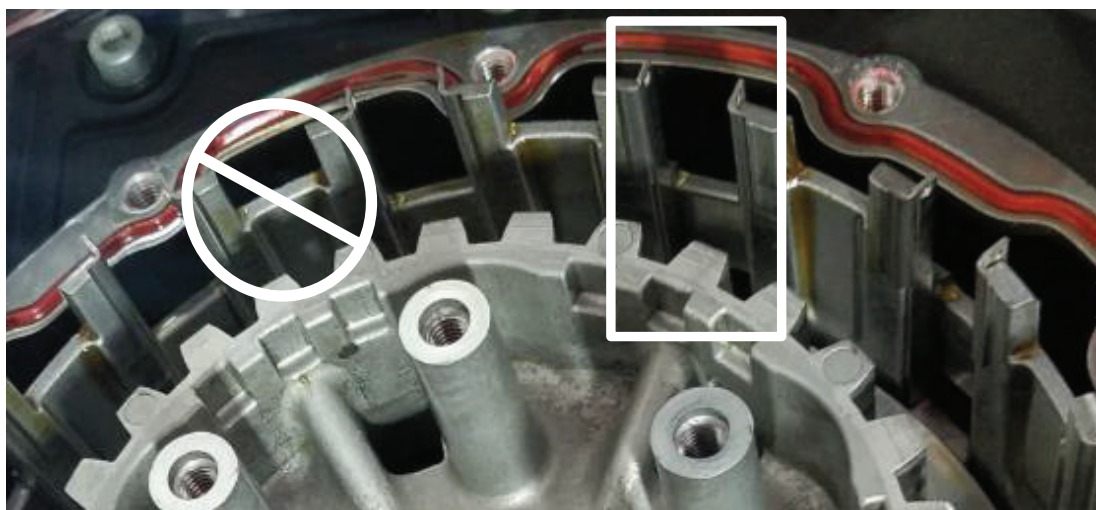

3. Before you begin, verify that the judder seat and spring are still installed in the basket. If they were removed, install the judder seat, then install the judder spring (cupped side up).

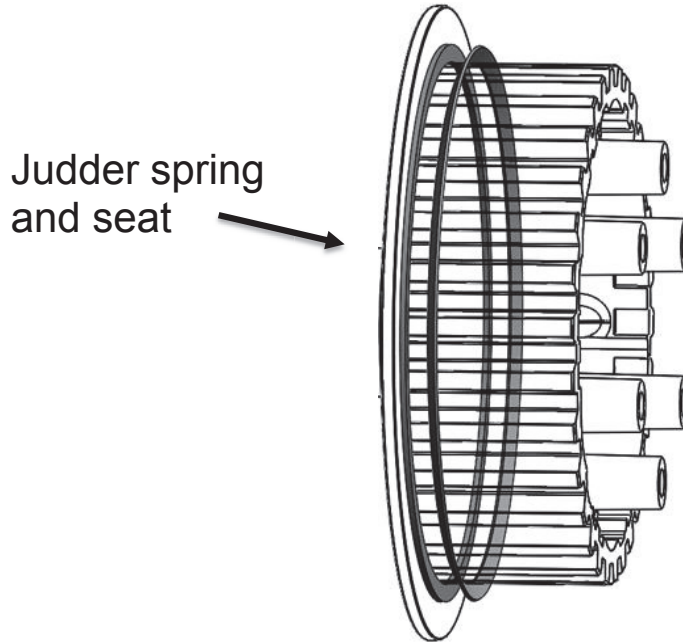

4. Install one of the thick TorqDrive® friction disks (.150 in), then install a thick steel drive plate (.065 in).

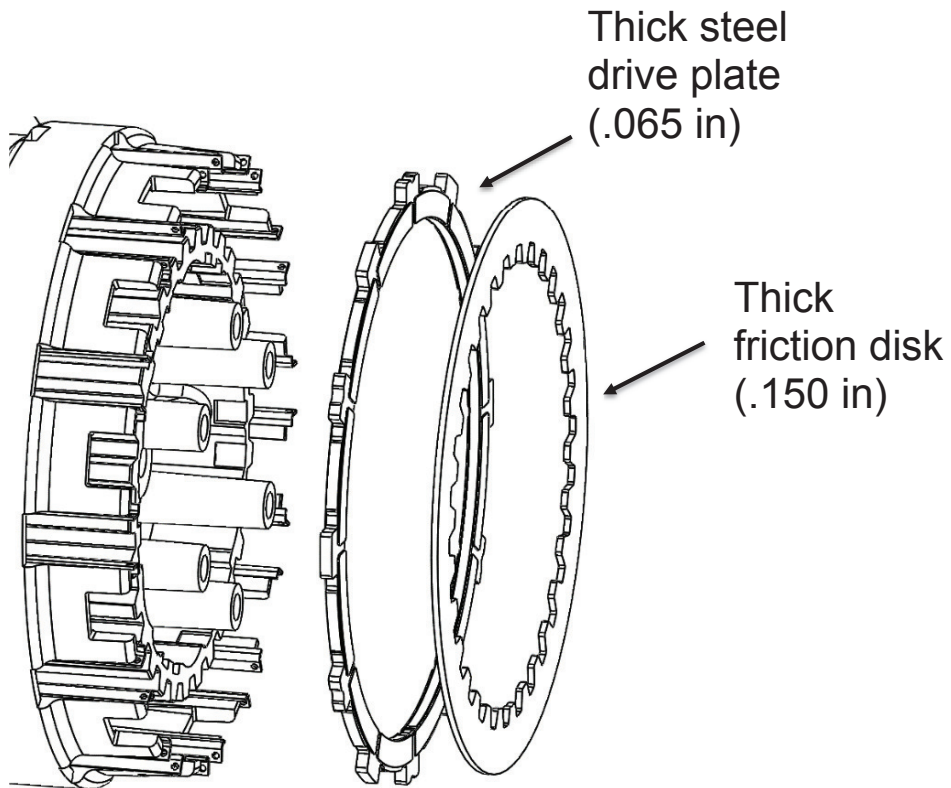

5. Alternate 10 friction disks with 9 steel drive plates.

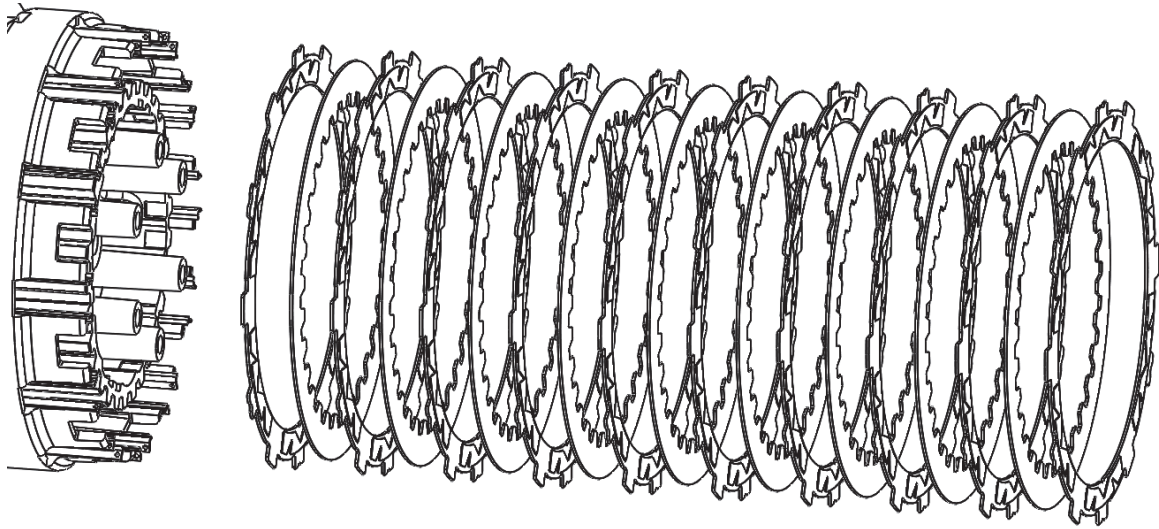

6. Next, add a thick steel drive plate, then add a thin friction disk.

7. Add the last thick steel drive plate, then add the last thick friction disk.

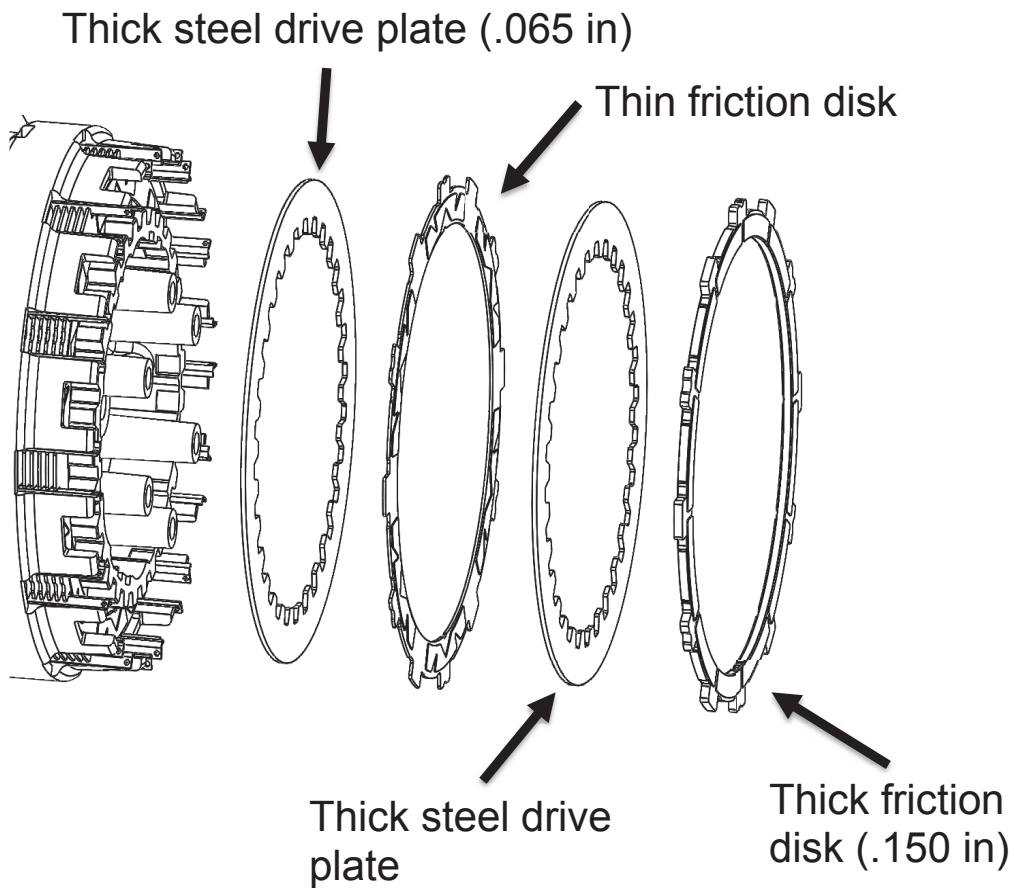

CLUTCH PACK CROSS-SECTION OVERVIEW:

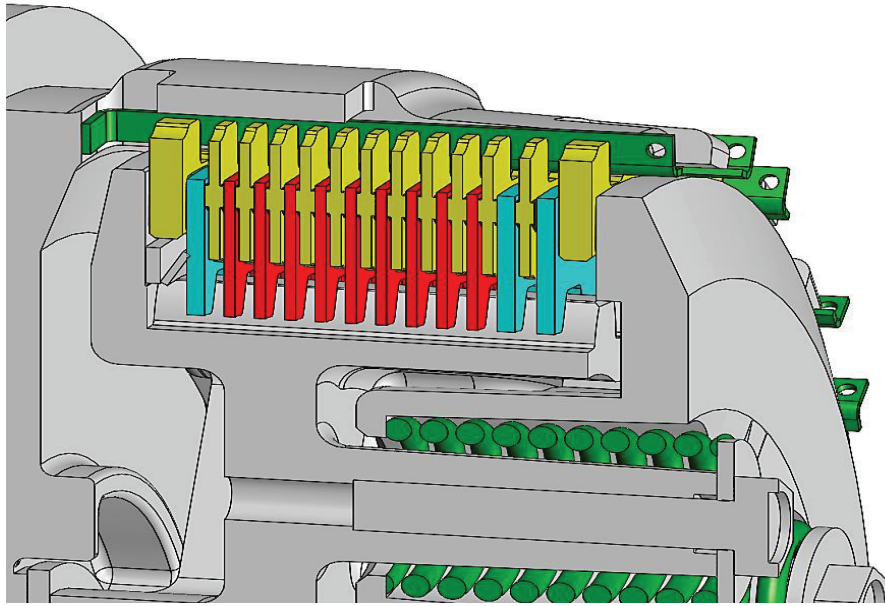

PRESSURE PLATE INSTALLATION

1. Reinstall the throw-out followed by the pressure plate.
2. Reinstall the OE springs and bolts. Torque to OE specifications.

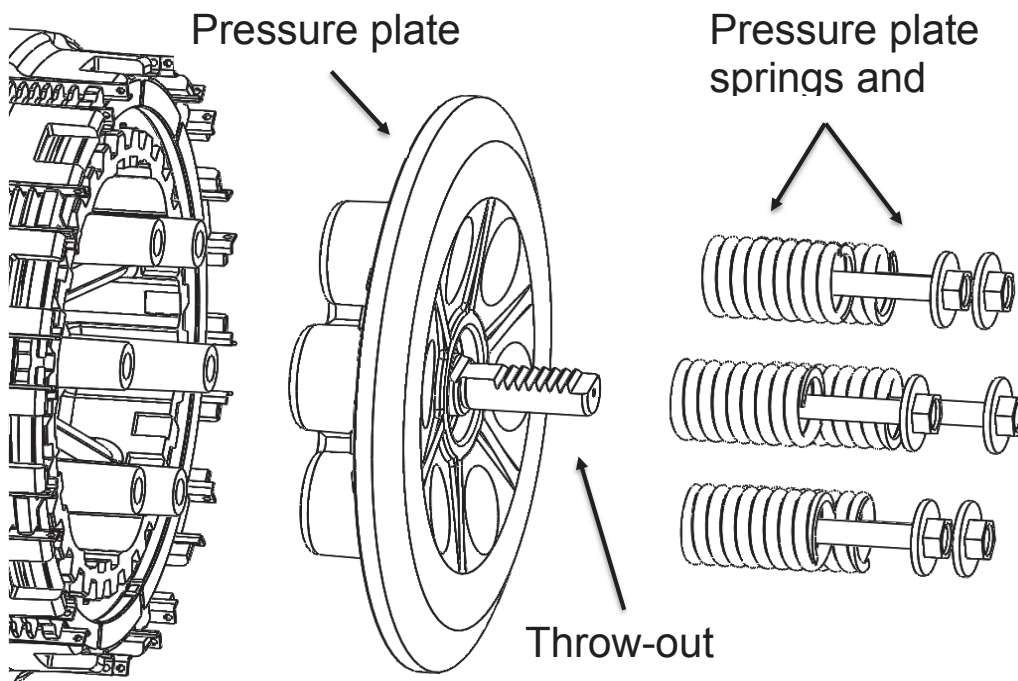

CLUTCH COVER INSTALLATION

Before securing the clutch cover in place or reattaching the clutch cable bracket to the engine, follow the next steps to achieve the correct actuator arm orientation to ensure adequate cable travel during use.

Note: *The clutch actuation mechanism is a rack and pinion system. Because there is limited cable adjustment at the in-line cable adjuster, you will be performing the major adjustment at the actuator shaft (pinion gear).*

1. Align the teeth on the throw-out with the actuator shaft in the clutch cover, then hold the clutch cover in place on the clutch.

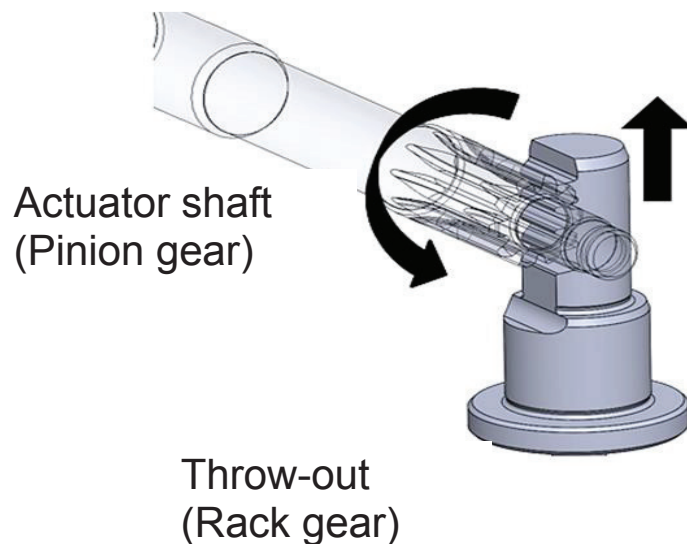

2.

3. Check that the actuator arm position is almost aligned as shown.

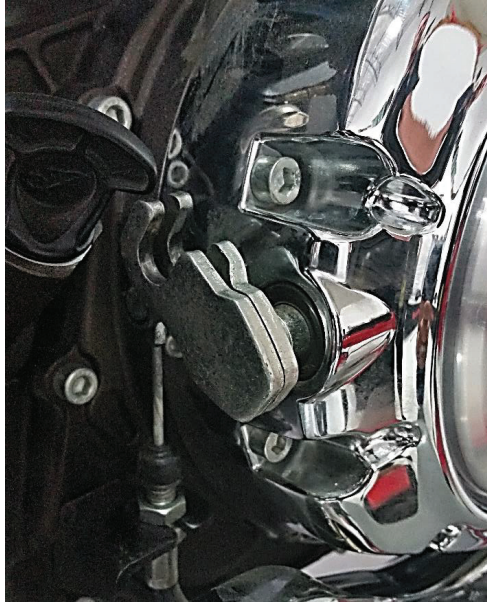

- a. If the actuator arm is in the correct position, continue with the step 3.
- b. If the actuator arm is not in the correct position, gently pull the cover off and move the actuator shaft a gear tooth on the throw-out. Replace the clutch cover and recheck the actuator arm position.

4. When the actuator arm is in the correct position, lightly tighten the cover bolts in a star pattern. Torque the bolts in small increments before tightening all the bolts to OE specifications.

5. Replace the clutch cable end into the actuator arm clevis.



6. Reinstall the cable bracket to the side of the engine and tighten the 2 engine bracket bolts.

7. Retighten the exhaust header pipe or clamps if they were loosened in the clutch removal step.

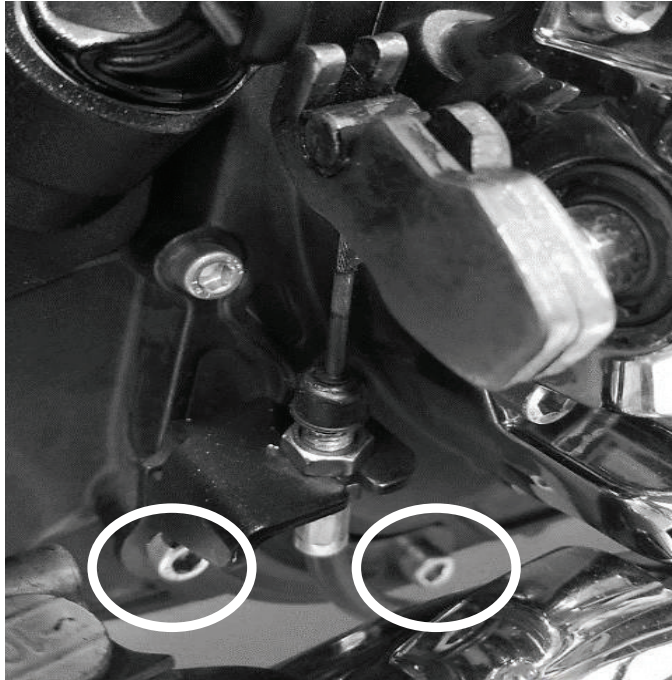

Note: An optional derby cover is available for the Indian Scout. If you purchased the Rekluse derby cover, install the cover now using the OE bolts.



FINISH INSTALLATION

1. On the underside of the bike, use a hex key to replace the two new crush washers and two drain screws, then add oil according to the OE instructions.

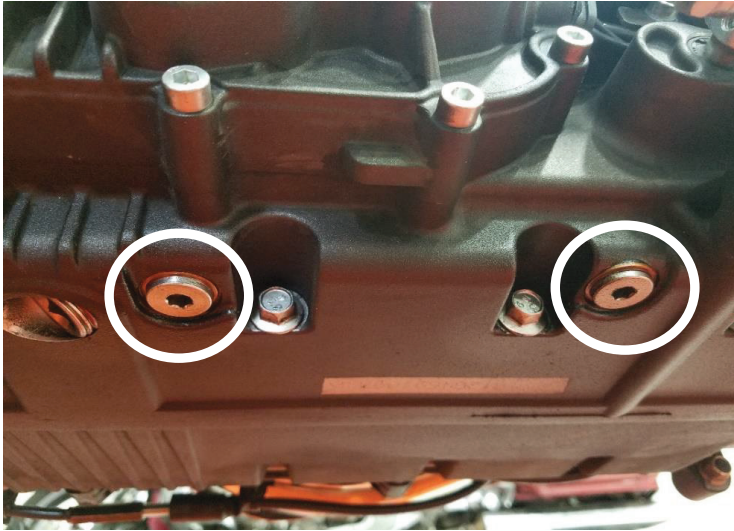

2. Check the clutch lever for free play. The clutch lever should move smoothly when it is pulled toward the handlebar and return quickly when it is released.

Note: Stock free play is the amount of lever movement from the perch to clutch lever engagement.

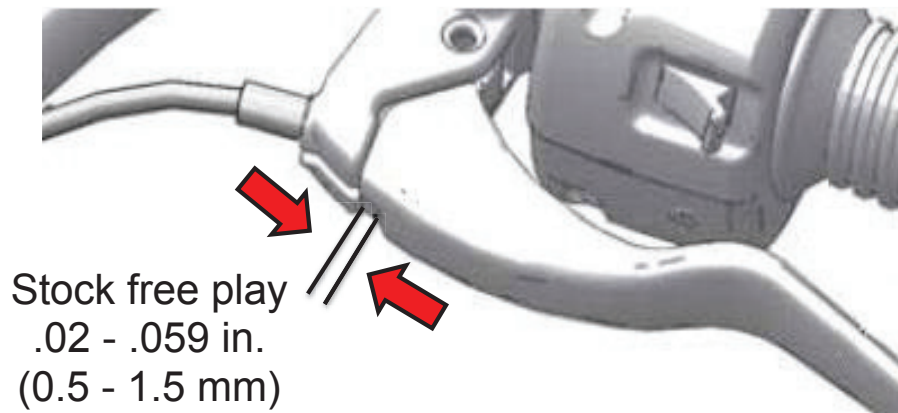

Stock free play
.02 - .059 in.
(0.5 - 1.5 mm)

3. Use the threaded cable tension adjuster along the right side frame (behind the lower exhaust header pipe) to adjust the free play.

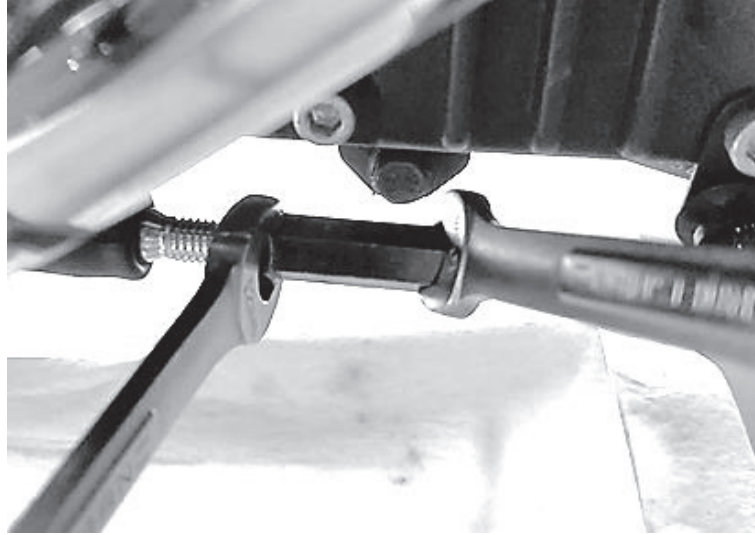

BREAK-IN

- The clutch will break in within 100-200 miles of normal riding. Until break-in is complete, you may experience more clutch drag than normal.
- It is recommended to do an oil change after the first 1,000 miles to drain any excess clutch debris that occurred from break-in.

MAINTENANCE

To keep your clutch performing at its best, perform regular maintenance on your bike and clutch.

- Keep up with regular oil changes according to the bike manufacturer's recommendations. Clutch performance and longevity depend on oil quality.
- For optimal clutch performance Rekluse recommends using fresh, clean oil that **meets JASO-MA** oil rating requirements.
- Inspect all of your clutch parts for signs of wear or excessive heat, and replace components as necessary. This includes

your basket sleeves and dampers. Clutch wear is dependent on the riders use.

Maintenance Protocol	Maintenance Intervals
Inspect all clutch parts for excessive wear or heat. Replace as needed.	Refer to OE service manual
Change oil, inspect and clean oil screen	Refer to OE service manual

- Measuring the clutch pack can help determine if the components need replacing. See the Setup Sheet for the specific clutch pack measurements.
- Repeat the break-in procedure anytime you replace the frictions disks. Always soak friction disks in oil for at least 5 minutes before installing.
- Replace friction disks if they measure below specifications or if the disks are glazed and/or burnt.
- Replace the drive plates if they show signs of excessive heat.

Disk inspection examples

When inspecting the clutch pack, the following pictures can be used as a reference. **These are best viewed in color by viewing this install document on www.rekluse.com/support.**

Drive Plates – If the clutch pack is getting high amounts of heat, purple, blue, or black color can be seen on the drive plate teeth. See pictures below. Not all drive plates look the same and may look different than pictured.

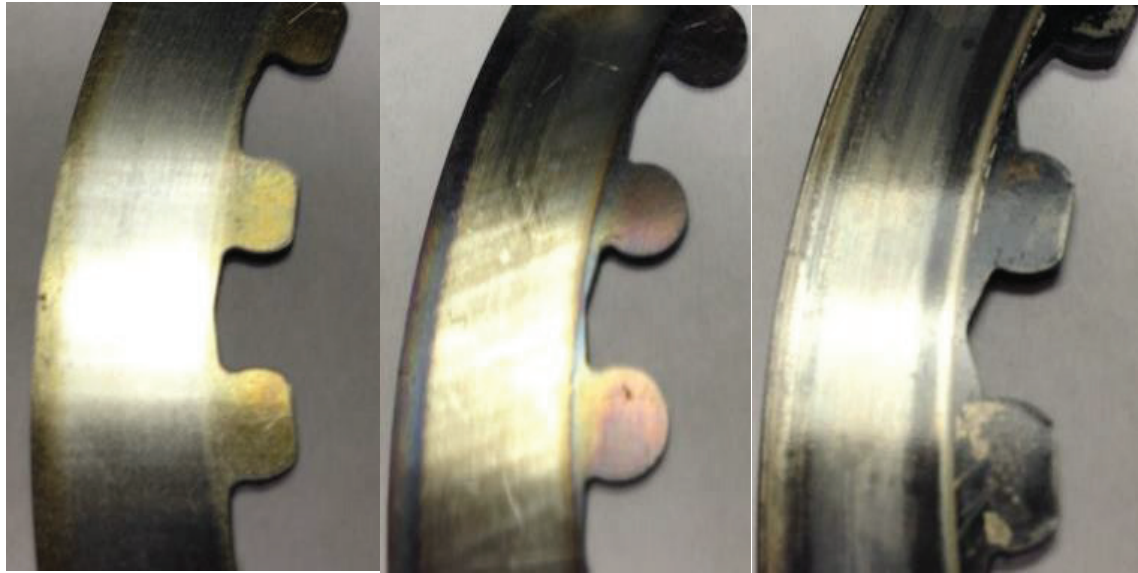

Normal Heat

High Heat
(Blue)

Excessive Heat
(Black)

Friction Disks – Due to the dark color of the friction material, the friction disks will appear almost black as soon as they are put in oil. During inspection, look for glazing of the friction material. Glazing will appear shiny and feel like glass, even after oil is cleaned from the friction disk. Not all friction disks look the same and may look different than pictured.



Normal Friction



Glazed Friction

TROUBLESHOOTING

Performance issues

- Inspect all of your clutch parts for signs of wear or excessive heat, and replace components as necessary. Clutch wear is dependent on the riders use.
- Measuring the clutch pack can help determine if the components need replacing.

Clutch Drag:

If drag occurs only while the bike is cold, oil is the most likely cause. Be sure to warm up the bike before riding and/or racing. Use of lighter weight oil can help to minimize cold drag.

Clutch Slip:

If clutch slip occurs, inspect the clutch for signs of wear or heat.

NEED ADDITIONAL HELP?

Website

www.rekluse.com/support

Frequently Asked Questions

www.rekluse.com/faq

Support Videos

www.rekluse.com/support/videos

Phone

(208) 426-0659

Technical Support

Contact Technical Support for questions related to product installation, tuning, and performance.

Hours:

Monday thru Friday: 8:00 a.m. - 5:00 p.m.

Mountain Time zone

Email: tech@rekluse.com

Customer Service

Contact Customer Service for additional product information, orders, and returns.

Hours:

Monday thru Friday: 8:00 a.m. - 5:00 p.m.

Mountain Time zone

Email: customerservice@rekluse.com