



# **INSTALLATION & USER'S GUIDE**

TorqDrive® Clutch Pack  
For cable-actuated bikes

Doc ID: 191-2813001A  
Revision: 090722

# **TABLE OF CONTENTS**

|   |    |
|---|----|
| OVERVIEW .....                            | 2  |
| INSTALLATION TIPS .....                   | 2  |
| TOOLS NEEDED.....                         | 3  |
| INCLUDED PARTS .....                      | 4  |
| DISASSEMBLE THE CLUTCH .....              | 5  |
| INSTALL THE CLUTCH PACK .....             | 7  |
| Notes for clutch pack installation: ..... | 7  |
| REINSTALL CLUTCH COVER.....               | 11 |
| BREAK-IN.....                             | 12 |
| TROUBLESHOOTING.....                      | 13 |
| Clutch Drag .....                         | 13 |
| Clutch Slip .....                         | 13 |
| MAINTENANCE.....                          | 13 |
| Disk inspection examples .....            | 14 |
| NEED ADDITIONAL HELP?.....                | 15 |

## **OVERVIEW**

This guide shows you how to replace your OE (Original Equipment) or “stock” clutch parts with your new Rekluse TorqDrive® clutch parts. The following parts are replaced:

- OE Drive Plates
- OE Friction Disks





## **INSTALLATION TIPS**

- Read the separate included Safety Information document before operating the vehicle with the product installed.
- Read this entire document before performing any steps.



- If you install this product for a customer or another person, instruct them to read the **Safety Information** document and the **Installation and User Guide** before operating the bike with the product.
- Protect eyes and skin – wear safety glasses and work gloves.
- Use the torque values listed in the instructions. Otherwise, use the torque specifications found in your OE service manual.
- For optimal clutch performance Rekluse recommends using fresh, clean oil that **meets JASO-MA** oil rating requirements. Rekluse offers Factory Formulated Oil™ developed specifically for Rekluse products. Rekluse Factory Formulated Oil is a perfect complement to any OEM or aftermarket wet clutch. Visit [www.rekluse.com](http://www.rekluse.com) to learn more.
- Inspect your OE cable for fraying and replace if needed.

## **TOOLS NEEDED**

|   |   |   |   |
|---|---|---|---|
|  | <br>8 mm | <br>10 mm |  |
| Fluid Catch Container   | 8 mm Socket   | 10 mm Socket  | Torque Wrench   |

# **INCLUDED PARTS**

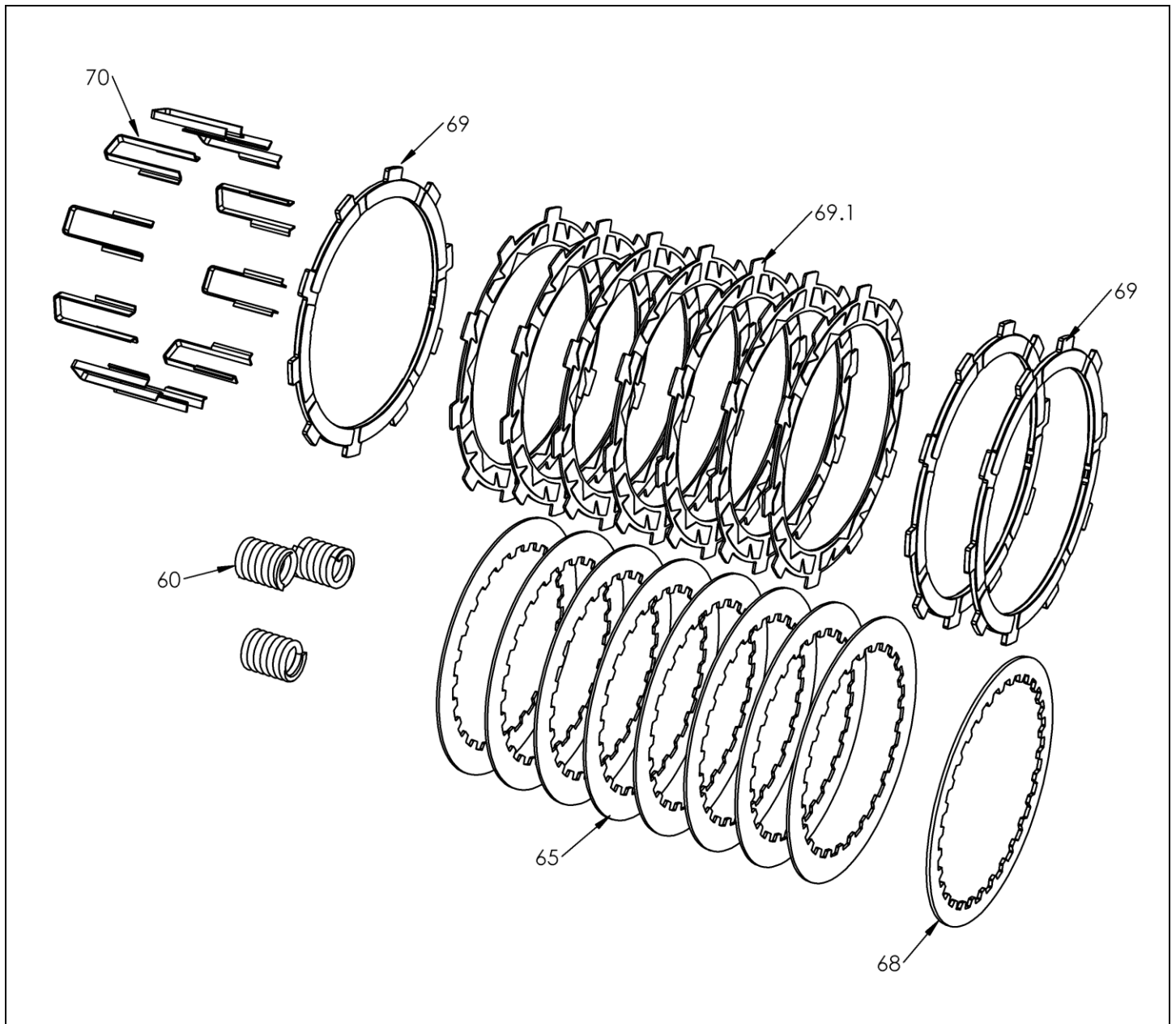

| <b>Item</b> | <b>Description</b>   | <b>Qty.</b> |
|-------------|--|-------------|
| 60          | Pressure plate springs   | 3           |
| 65          | Steel drive plates - .048 in (1.2 mm)  | 8           |
| 68          | Thick steel drive plate - .065 in (1.6 mm)   | 1           |
| 69          | Thick TorqDrive <sup>®</sup> friction disks with larger internal diameter - .118 in (3 mm) | 3           |
| 69.1        | Thin TorqDrive <sup>®</sup> friction disks   | 7           |
| 70          | Basket sleeves   | 10          |

Visit [www.rekluse.com/support](http://www.rekluse.com/support) for a full parts fiche illustration and part numbers.

# **DISASSEMBLE THE CLUTCH**

1. Soak the Rekluse friction disks in new oil for at least 5 minutes. Coat the friction disks on both sides.

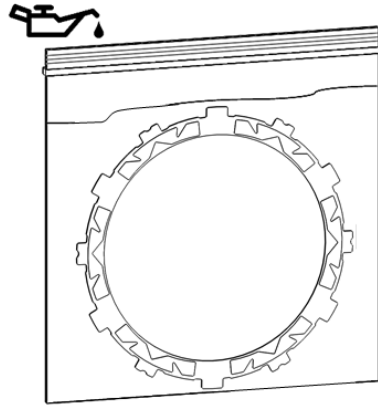

2. Prepare the bike for the installation. Lay the bike on its left side to eliminate draining the oil.
  - If you prefer, you can stand the bike on its center stand and drain the oil.
3. On the actuator arm, use a screwdriver to bend up the lock tab that secures the clutch cable, then unhook the clutch cable from the clutch actuator arm.

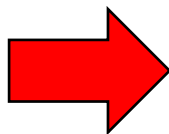

4. Remove any bracket(s) or parts block the removal of the clutch cover.

5. Remove the clutch cover bolts, then remove the cover. Set the cover and cover gasket aside. They will be reused.
6. Use a 10 mm socket to remove the 3 pressure plate bolts, then remove the spring ring and pressure plate springs. The bolts and spring ring will be reused.
7. Remove the pressure plate, then remove the OE clutch pack. The pressure plate, judder seat, and judder spring will be reused.

**NOTE:** *The judder spring and seat can remain in the clutch basket.*

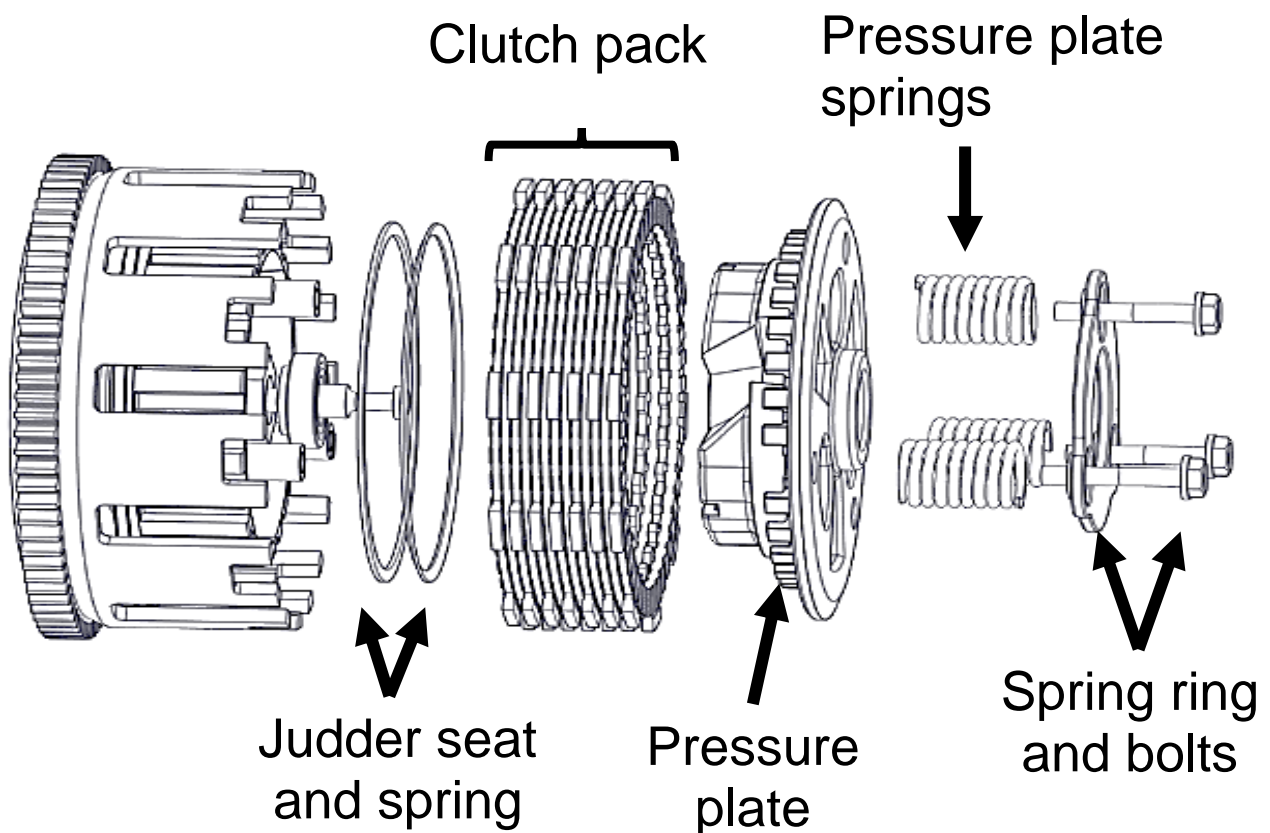



# **INSTALL THE CLUTCH PACK**

## **Notes for clutch pack installation:**

- *Some friction disks are marked with a small colored dot. This mark is used for processing and can be ignored.*
- *Some OE basket have “half slots” at the top of the basket tangs. Rekluse products require the entire clutch pack be installed into the MAIN (deeper) basket slots.*

Use main (deeper)  
basket slots

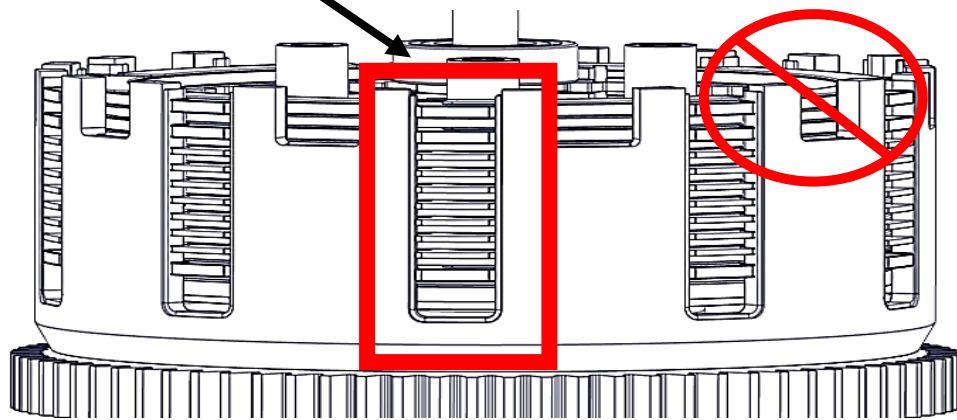

1. Inspect the clutch basket for spring damper play or notching. Do not install sleeves or use product with a notched basket. Notched basket tang faces or worn spring dampers can cause the sleeves to break.

### **⚠ WARNING**

**Failure to inspect the basket and replace if necessary could result in death, serious injury, and/or property damage.**

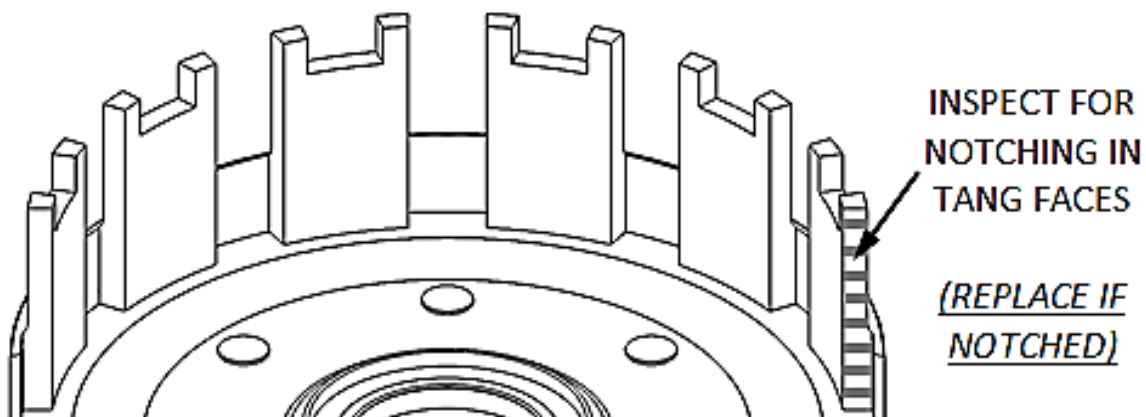

2. Install all the Rekluse basket sleeves into the basket slots. Make sure the bottom of the sleeve is facing down, and the sleeve tabs sit against the inside of the basket.

**NOTE:** When seated in the basket, the sleeves will sit flush with the top of the basket. This is normal.

Sleeve tabs  
sit inside the  
basket

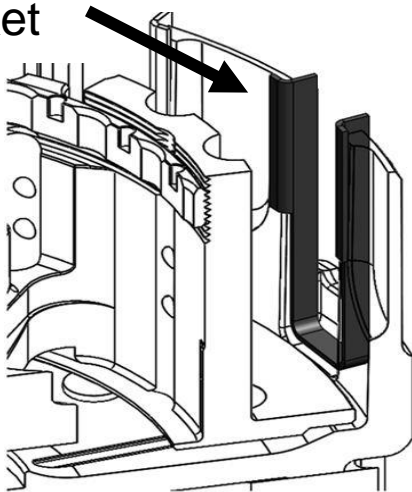

Install all the basket sleeves

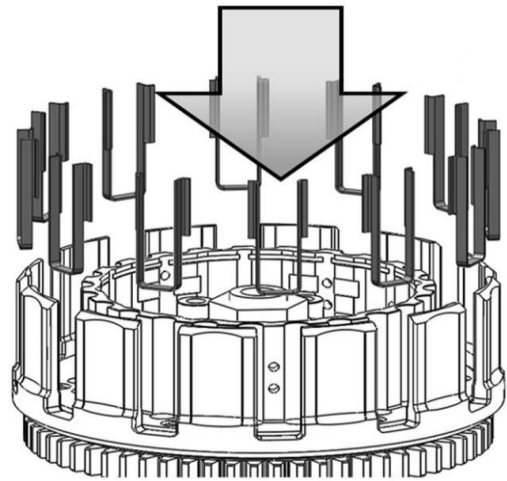

3. Double-check that the OE judder seat and spring are installed in the bottom of the basket.
4. Install a thick friction disk - .118 in (3 mm) into the clutch basket. *The friction disk will sit around the judder spring.*

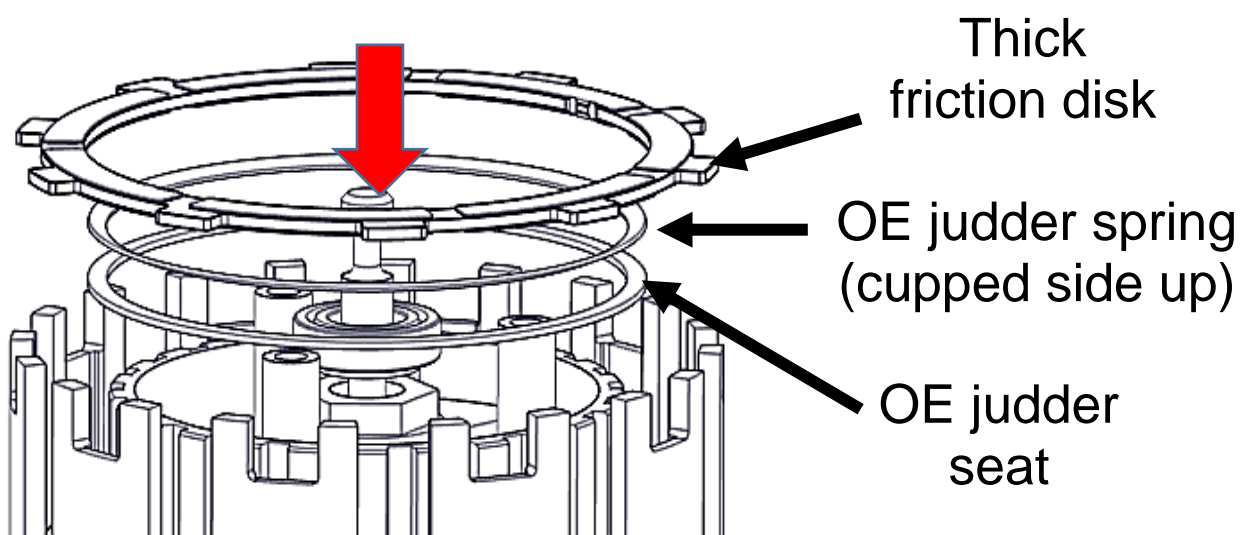

5. Install a thin steel drive plate - .048 in (1.2 mm) on top of the friction disk and the judder spring, then alternate thin friction disk with thin steel drive plates.



6. Install a thick friction disk on top of the last thin steel drive plate. *You will have 1 thick friction and 1 thick steel drive plate left over. These are installed on the pressure plate.*
7. Set the pressure plate upside down on a workbench. Install the last **thick** friction disk - .118" (3 mm) on top of the pressure plate.
8. Install the **thick** steel drive plate - .065" (1.6 mm) on top of the thick friction. Make sure the drive plate's teeth index to the pressure plate.

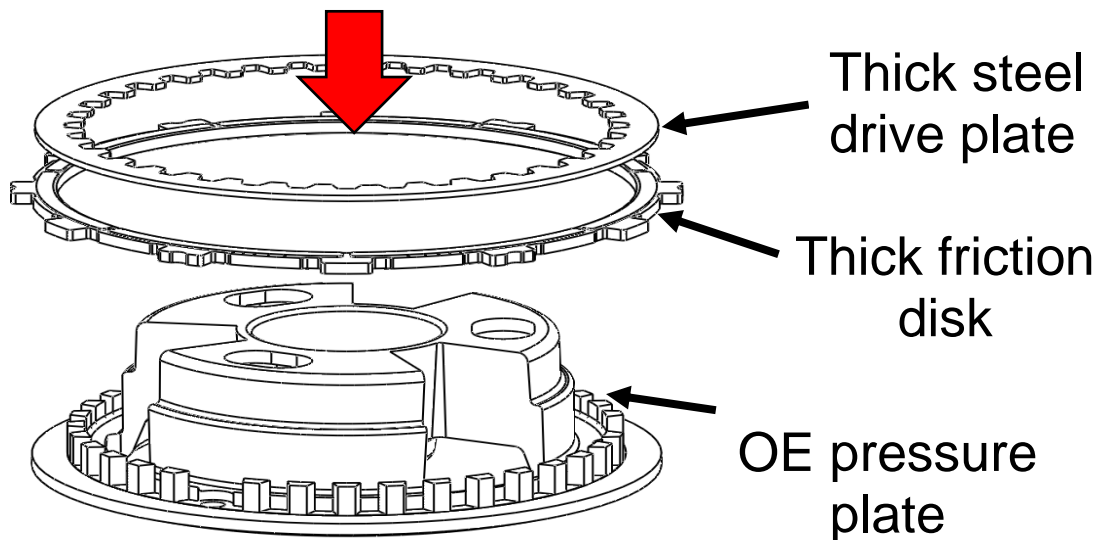

9. Turn the pressure plate assembly over and set it on top of the clutch pack. *Make sure all of the friction disk tabs are aligned in the correct basket slot.*

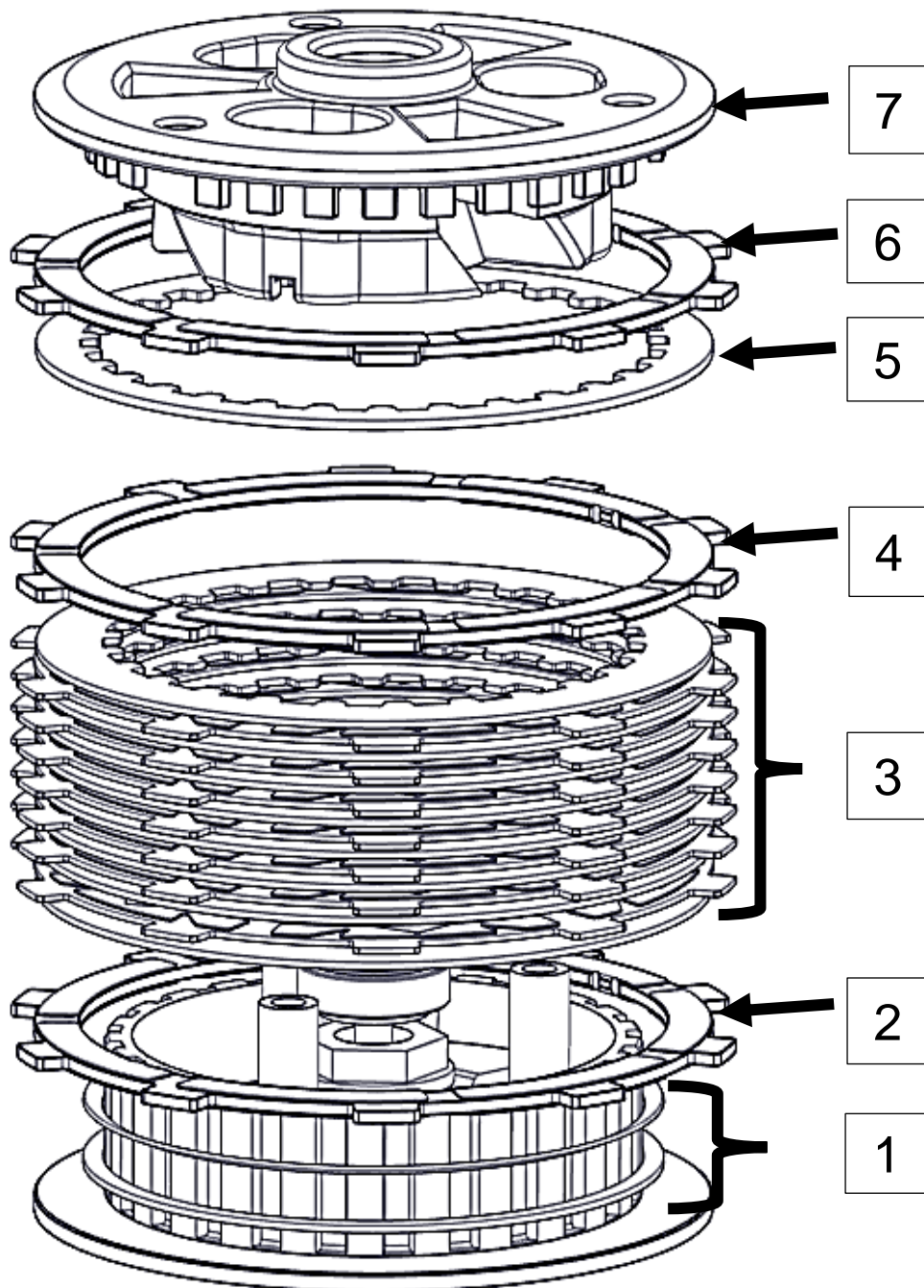

|   |  |
|---|--|
| 1 | Judder seat, then judder spring                            |
| 2 | Thick friction disk  |
| 3 | Alternate thin steel drive plates with thin friction disks |
| 4 | Thick friction disk  |
| 5 | Thick steel drive plate                                    |
| 6 | Thick friction disk  |
| 7 | Pressure plate   |

10. Install the new Rekluse springs, then reinstall the OE spring ring and OE bolts.
11. Torque pressure plate bolts in small increments to 7.4 ft-lb (10 N-m) as per OE specifications.

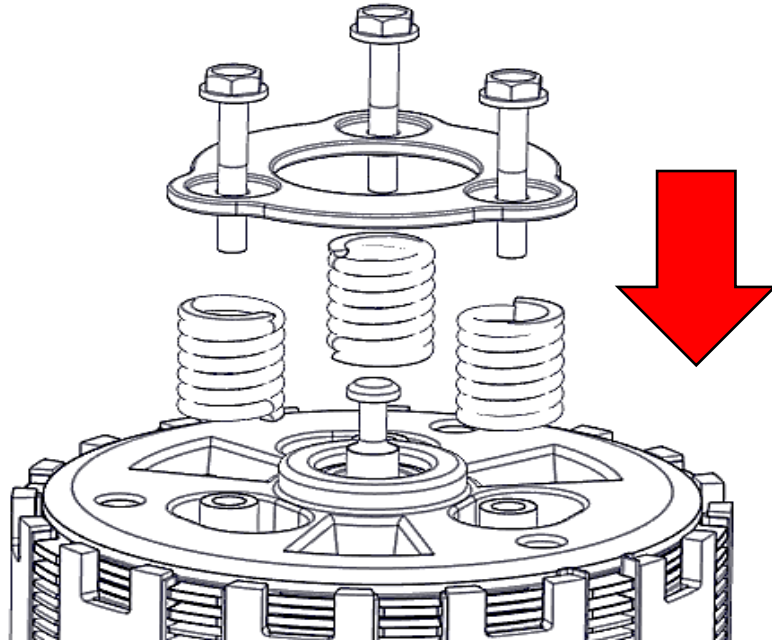

## **REINSTALL CLUTCH COVER**

1. Reinstall the clutch cover gasket onto the clutch cover.  
*Replace the gasket if it shows signs of damage or wear to prevent leaks.*
2. Pull the actuator arm toward the front of the cover so that it is parallel with the side of the cover.



3. Hold the actuator arm in this position while reinstalling the clutch cover, making sure the throw-out rod seats into the cover.
4. Reinstall the clutch cover bolts.
5. Lightly tighten the cover bolts in a star pattern.
6. Torque all the cover bolts in small increments in a star pattern to **8.9 ft-lb (12 N-m)** as per OE specifications.
7. Reattach the clutch cable to the actuator arm, then use a screwdriver to fold down the tab lock.
8. Reinstall any bracket(s) or parts that were removed in the disassembly.
9. Check the clutch lever for free play. The clutch lever should move smoothly when it is pulled toward the handlebar and return quickly when it is released.

**NOTE:** Stock free play is the amount of lever movement from the perch to clutch lever engagement. Clutch lever free play should measure .04-1.2" (1-3 mm).

## **BREAK-IN**

- The clutch will break in within 100-200 miles of normal riding. Until break-in is complete, you may experience more clutch drag than normal.
- It is recommended to do an oil change after the first 1,000 miles to drain any excess clutch debris that occurred from break-in.

# TROUBLESHOOTING

## **Clutch Drag:**

If drag occurs only while the bike is cold, oil is the most likely cause. Be sure to warm up the bike before riding and/or racing. Use of lighter weight oil can help to minimize cold drag.

## **Clutch Slip:**

If clutch slip occurs, inspect the clutch for signs of wear or heat.

# MAINTENANCE

To keep your clutch performing at its best, perform regular maintenance on your bike and clutch. Clutch longevity and performance is greatly increased with oil quality and other bike factors that reduce engine heat.

- Inspect all of your clutch parts at regular maintenance intervals for signs wear or excessive heat and replace components as necessary. Clutch wear is dependent on the riders use.
- Measuring the clutch pack can help determine if the components need replacing.
  - Minimum clutch pack height: 1.210 inches
  - Maximum clutch pack height: 1.330 inches
- Inspect and replace basket sleeves if they appear to be notched from friction disks.
- Replace friction disks if they are glazed and/or burnt.
- Keep up with regular oil changes as per the bike manufacturer's recommendations. Clutch performance and longevity depend on oil quality.
- For optimal clutch performance Rekluse recommends using fresh, clean oil that **meets JASO-MA** oil rating requirements.



## Disk inspection examples

When inspecting the clutch pack, the following pictures can be used as a reference. **These are best viewed in color by viewing this install document at [www.rekluse.com/support](http://www.rekluse.com/support).**

**Drive Plates** – If the clutch pack is getting high amounts of heat, purple, blue, or black color can be seen on the drive plate teeth. See pictures below. Not all drive plates look the same and may look different than pictured.



Normal Heat

High Heat  
(Blue)

Excessive Heat  
(Black)

**Friction Disks** – Due to the dark color of the friction material, the friction disks will appear almost black as soon as they are put in oil. During inspection, look for glazing of the friction material. Glazing will appear shiny and feel like glass, even after oil is cleaned from the friction disk. Not all friction disks look the same and may look different than pictured.



Normal  
Friction



Glazed  
Friction



# **NEED ADDITIONAL HELP?**

## **Website**

[www.rekluse.com/support](http://www.rekluse.com/support)

## **Frequently asked questions**

[www.rekluse.com/faq](http://www.rekluse.com/faq)

## **Support Videos**

[www.rekluse.com/support/videos](http://www.rekluse.com/support/videos)

## **Phone**

(208) 426-0659

## **Technical Support**

Contact Technical Support for questions related to product installation, tuning, and performance.

### **Hours:**

Monday thru Friday: 8:00 a.m. - 5:00 p.m.

Mountain Time zone

Email: [tech@rekluse.com](mailto:tech@rekluse.com)

## **Customer Service**

Contact Customer Service for additional product information, orders, and returns.

### **Hours:**

Monday thru Friday: 8:00 a.m. - 5:00 p.m.

Mountain Time zone

Email: [customerservice@rekluse.com](mailto:customerservice@rekluse.com)

