



INSTALLATION & USER'S GUIDE

Adventure TorqDrive® Clutch
For BMW F650, F700 and F800 Parallel Twin

Doc ID: 191-2805A
Revision: 040919

TABLE OF CONTENTS

OVERVIEW	2
INSTALLATION TIPS	2
TOOLS NEEDED.....	4
INCLUDED PARTS	5
DISASSEMBLE THE CLUTCH	6
CLUTCH PACK INSTALLATION.....	9
Notes for installation.....	9
BREAK-IN.....	14
TROUBLESHOOTING.....	14
Clutch Drag	14
Clutch Slip	15
MAINTENANCE.....	15
Disk inspection examples	16
NEED ADDITIONAL HELP?.....	17

OVERVIEW

This guide shows you how to replace your OE (Original Equipment) or “stock” clutch parts with your new Rekluse TorqDrive® clutch parts. The following parts are replaced:

- OE Drive Plates
- OE Friction Disks





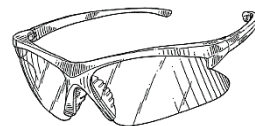



INSTALLATION TIPS

- Read the separate included Safety Information document before operating the vehicle with the product installed.
- Read this entire document before performing any steps.



- If you install this product for a customer or another person, instruct them to read the **Safety Information** document and the **Installation and User Guide** before operating the bike with the product.
- Protect eyes and skin – wear safety glasses and work gloves.
- Lay the motorcycle on its left side when replacing the clutch. This makes working on the clutch easier and eliminates the need to drain the oil. Catch any fuel that may drain from the bike.
- Use the torque values listed in the instructions. Otherwise, use the torque specifications found in your OE service manual.
- For optimal clutch performance Rekluse recommends using fresh, clean oil that **meets JASO-MA** oil rating requirements. Rekluse offers Factory Formulated Oil™ developed specifically for Rekluse products. Rekluse Factory Formulated Oil is a perfect complement to any OEM or aftermarket wet clutch. Visit www.rekluse.com to learn more.

TOOLS NEEDED

	 6 mm	 T-45 Torx Bit	
Fluid Catch Container	6 mm Socket	T45 Torx Bit	Torque Wrench
		 8 mm	
Metric Hex Key Set	Channel-lock Pliers	8 mm Socket	Pick

INCLUDED PARTS

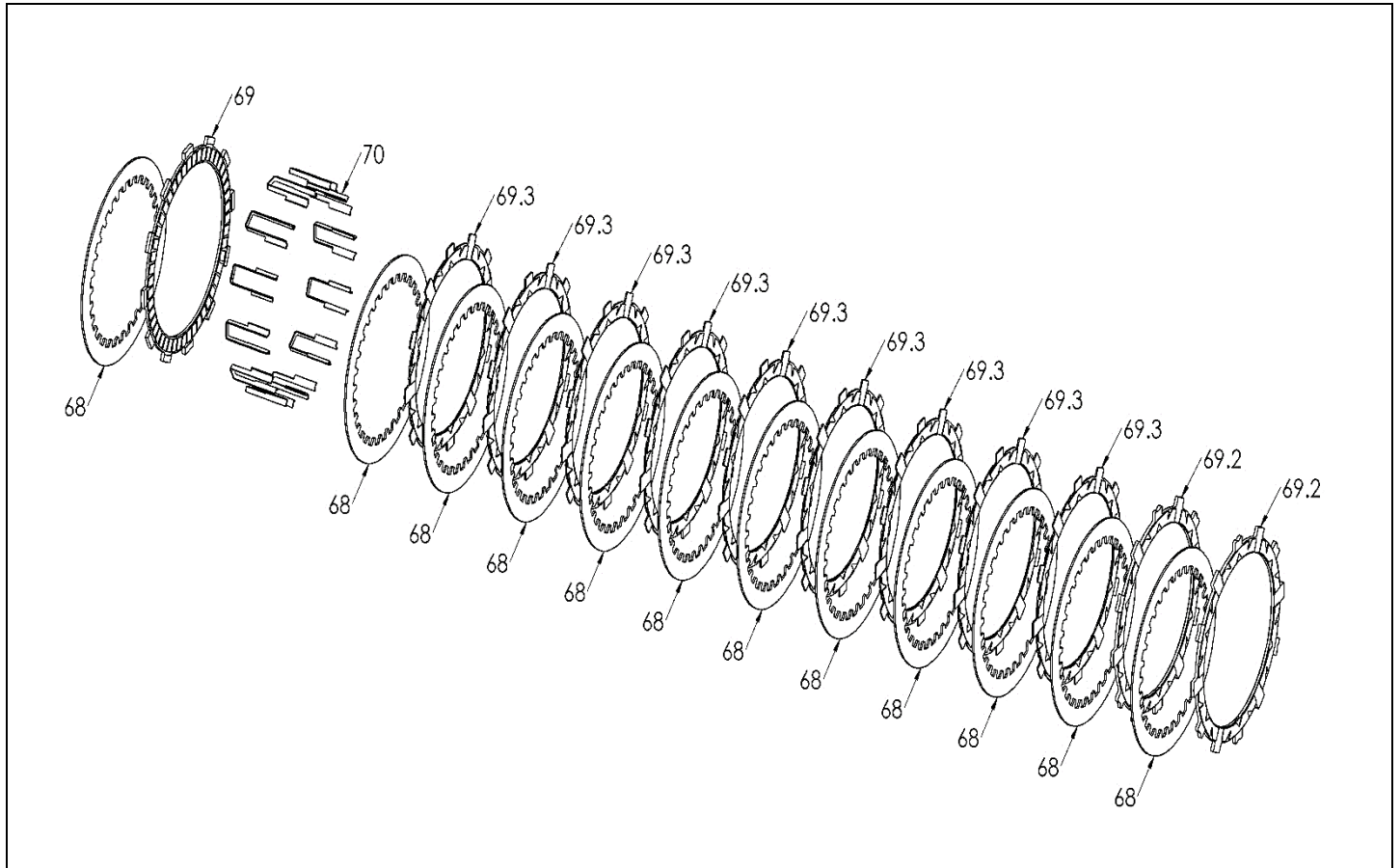

Item	Description	Qty.
68	Steel drive plates	12
69	Thick friction disks - .124" (3.15 mm)	1
69.2	Notched friction disks - .137" (3.48 mm)	2
69.3	Thin friction disk	9
70	Basket sleeves	12

Visit www.rekluse.com/support for a full parts fiche illustration and part numbers.

DISASSEMBLE THE CLUTCH

1. Soak the Rekluse friction disks in new oil for at least 5 minutes. Make sure the friction disks are coated on both sides.

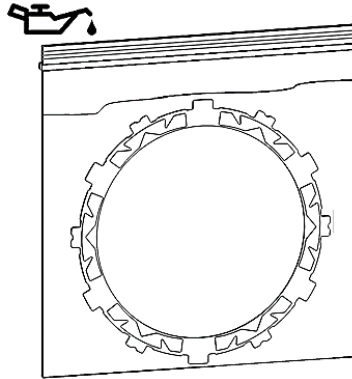

2. Stand the bike on a suitable bike stand, then drain the oil into a suitable container.
3. Use a T45 Torx bit to remove the left side kickstand bracket, being careful not to damage the electronics or wires that protrude from the bracket.
4. Use a 6 mm socket to remove the shift lever.
5. Using channel-lock style pliers, turn the actuator arm and detach the clutch cable from the actuator arm.
6. Loosen the jam nut and unthread the nut from the cable adjuster.

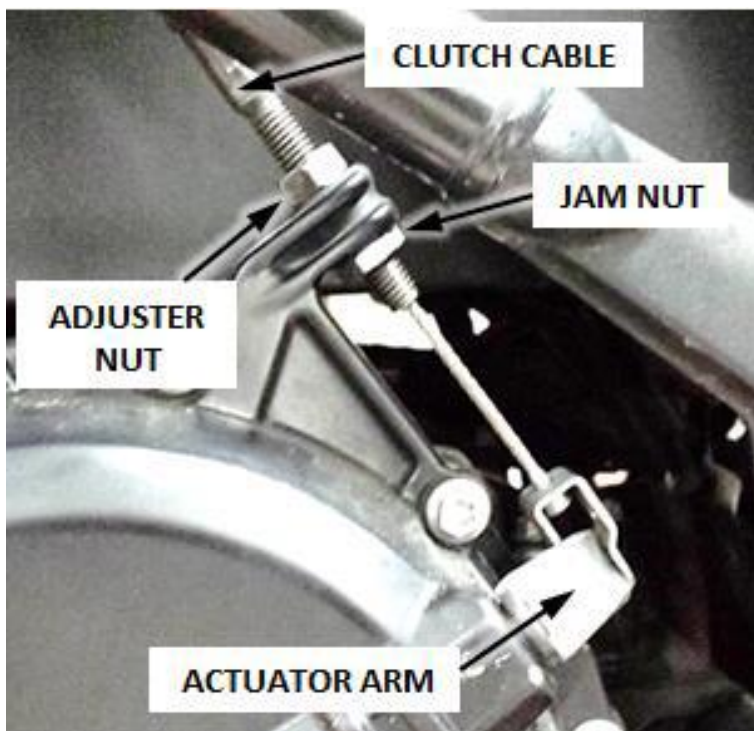

7. Detach the clutch cable from the clutch cover, then remove the oil fill cap.

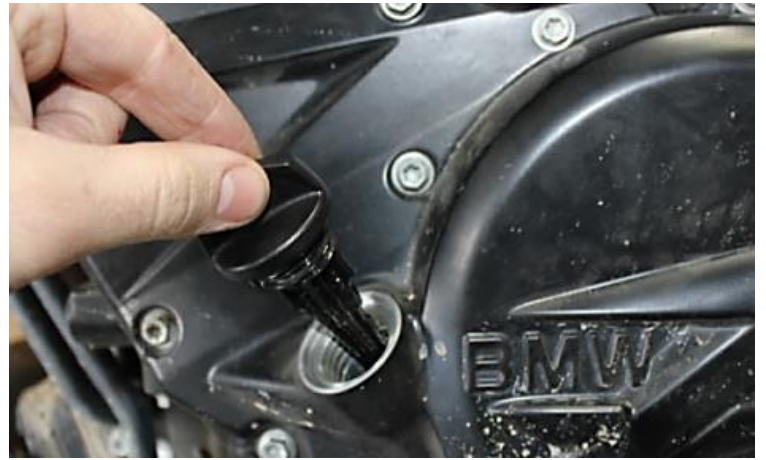

8. Use an 8 mm socket to remove the clutch cover bolts.
9. Remove the clutch cover and gasket. Set these aside. They will be reused.

Note: *Replace the OE gasket if it is torn or damaged.*

10. Check the location of the shifter shaft washer. The washer may stick to the back of the clutch cover when it is removed. If this happens, place the washer back on the shifter shaft. See pictures for reference.

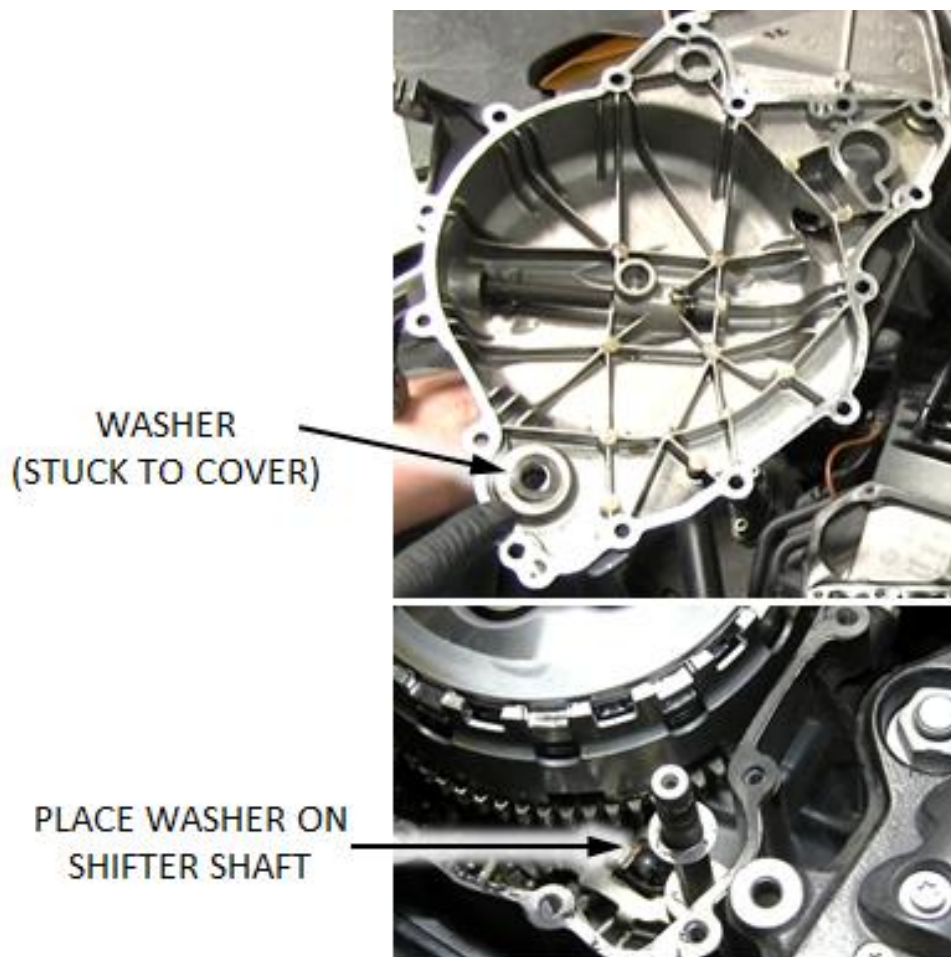

11. Remove the OE pressure plate bolts and springs, then remove the throw-out and pressure plate.

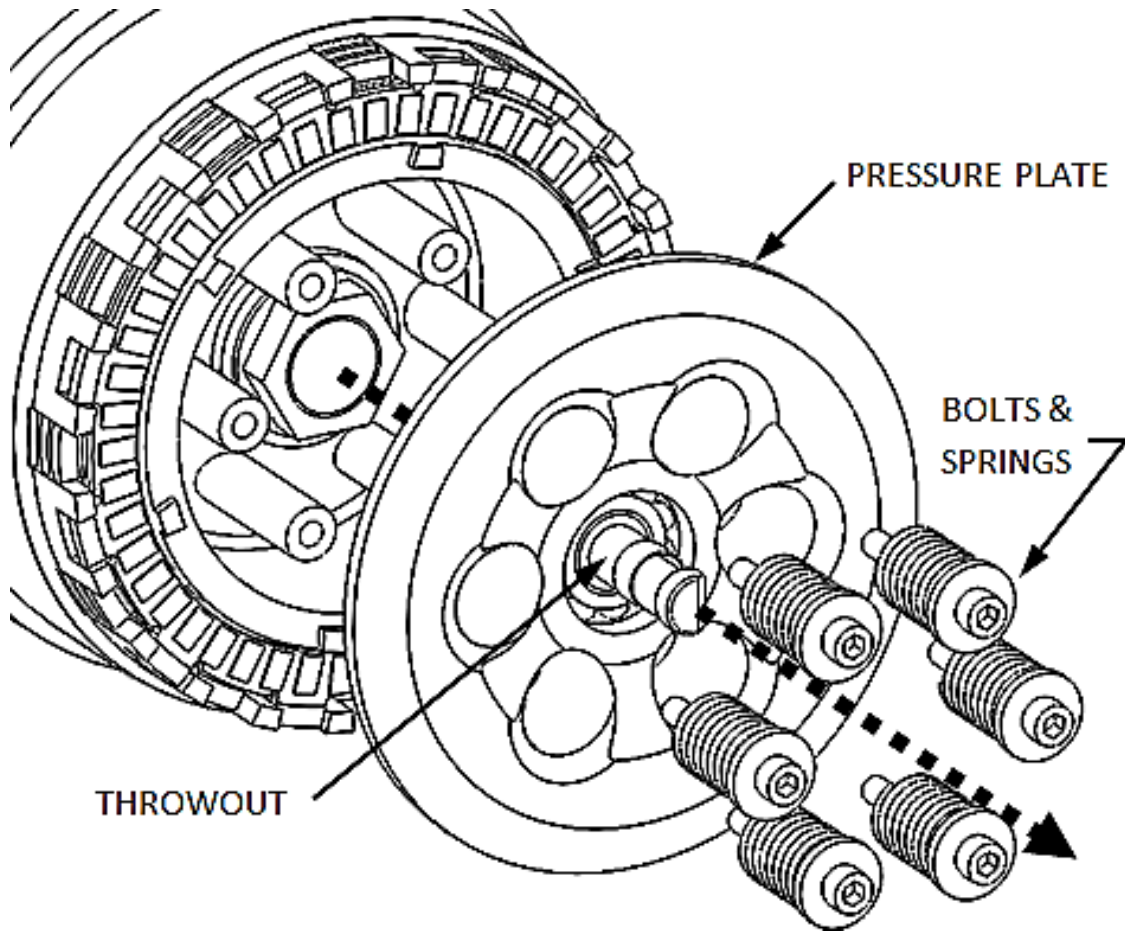

12. Remove the entire OE clutch pack.

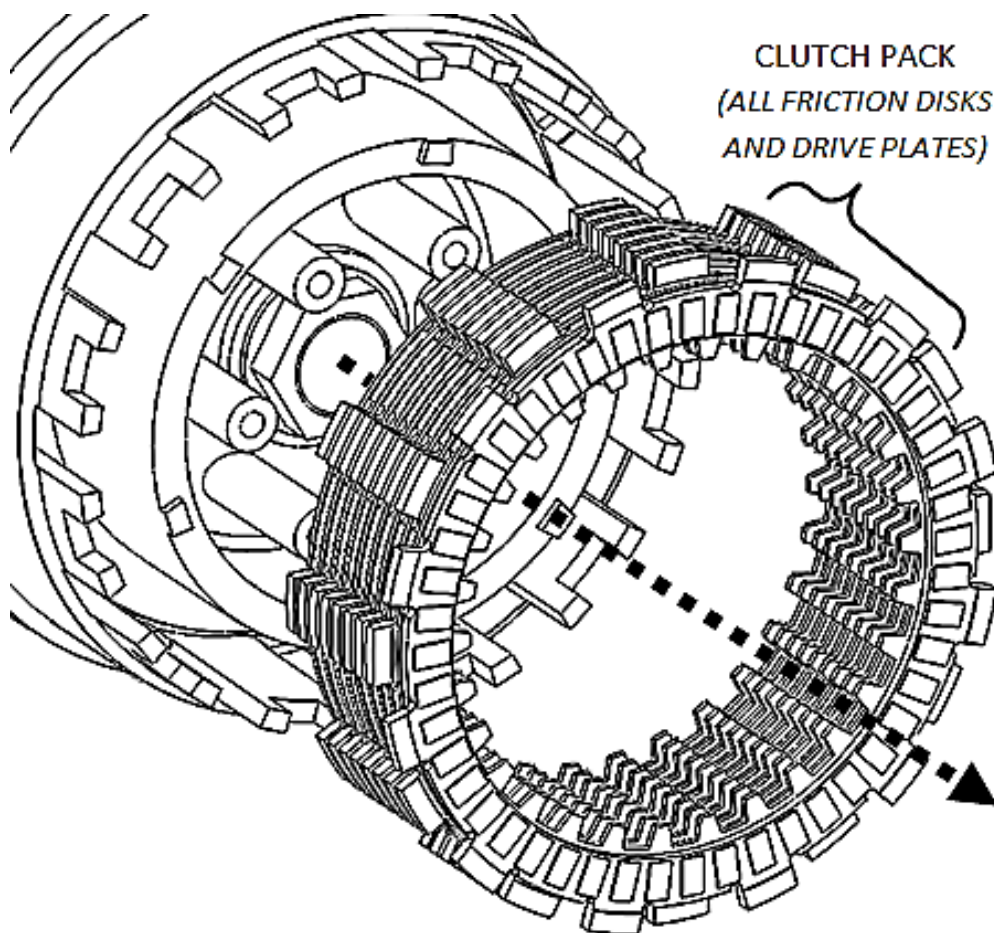

CLUTCH PACK INSTALLATION

Notes for installation

- *When assembling the clutch pack, it is important to line up the alignment tab notches on the last 2 friction disks. Only the last two friction disks installed have alignment notches.*

Align notches of
friction disks

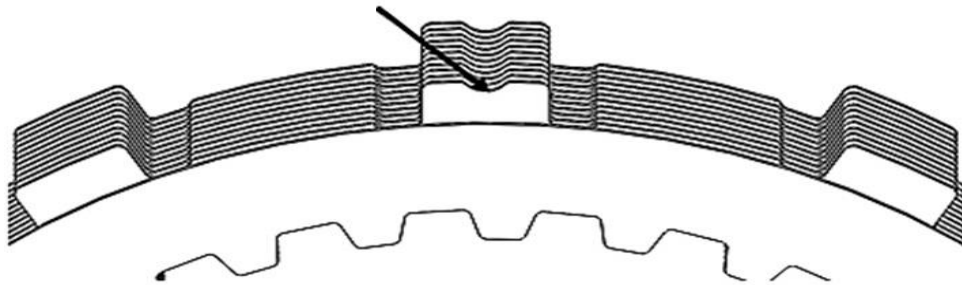

- *Some friction disks are marked with a small colored dot. This mark is used for processing and can be ignored.*
- *Some OE basket have “half slots” at the top of the basket tangs. Rekluse products require the entire clutch pack be installed into the MAIN (deeper) basket slots. Do not use the “half slots.”*

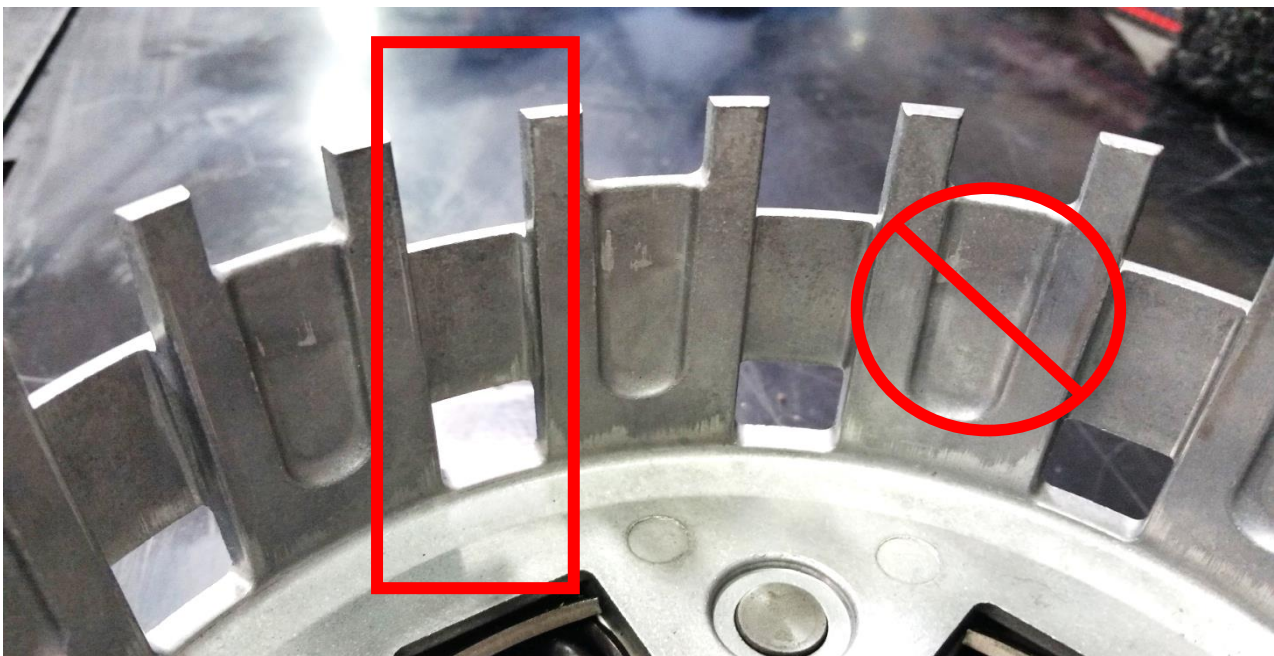

1. **Inspect the clutch basket for spring damper play or notching. Do not install sleeves or use product with a notched basket. Notched basket tang faces or worn spring dampers can cause the sleeves to break.**

⚠ WARNING

Failure to inspect the basket and replace if necessary could result in death, serious injury, and/or property damage.

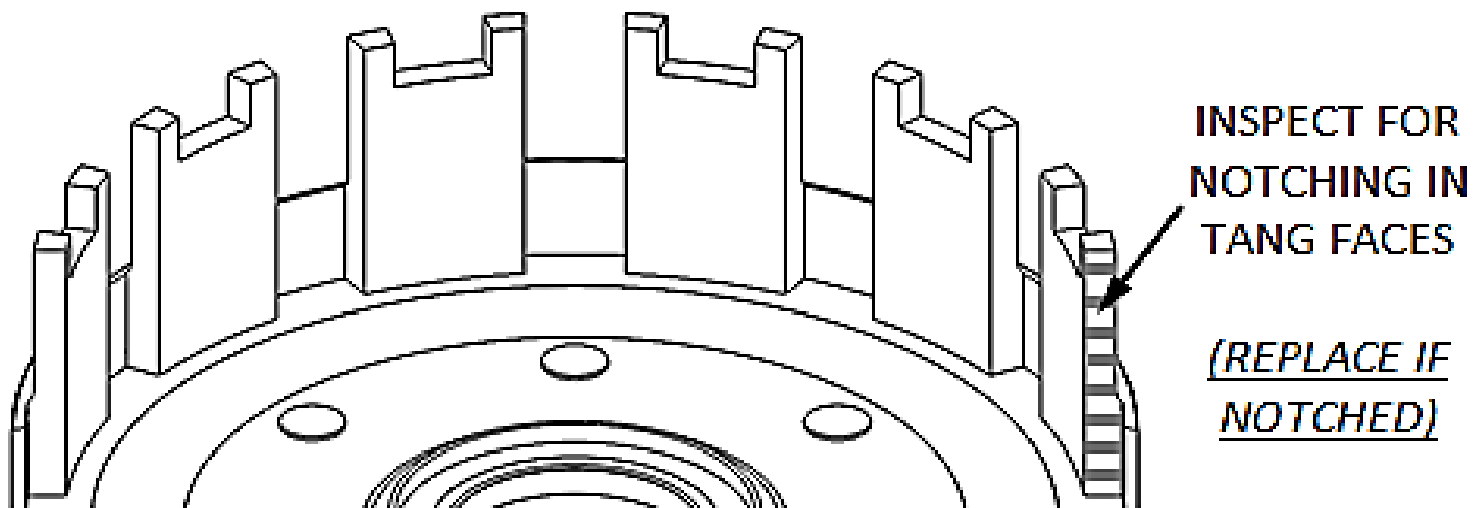

2. Separate the thick friction disk - .124" (3.15 mm) and the 2 notched friction disks - .137" (3.48 mm) from the clutch pack. These will be installed in specific positions.
3. Because of the OE basket design, begin by installing a steel drive plate, then installing the thick friction disk - .124" (3.15 mm) into the clutch basket. *This friction looks like an OE friction.*

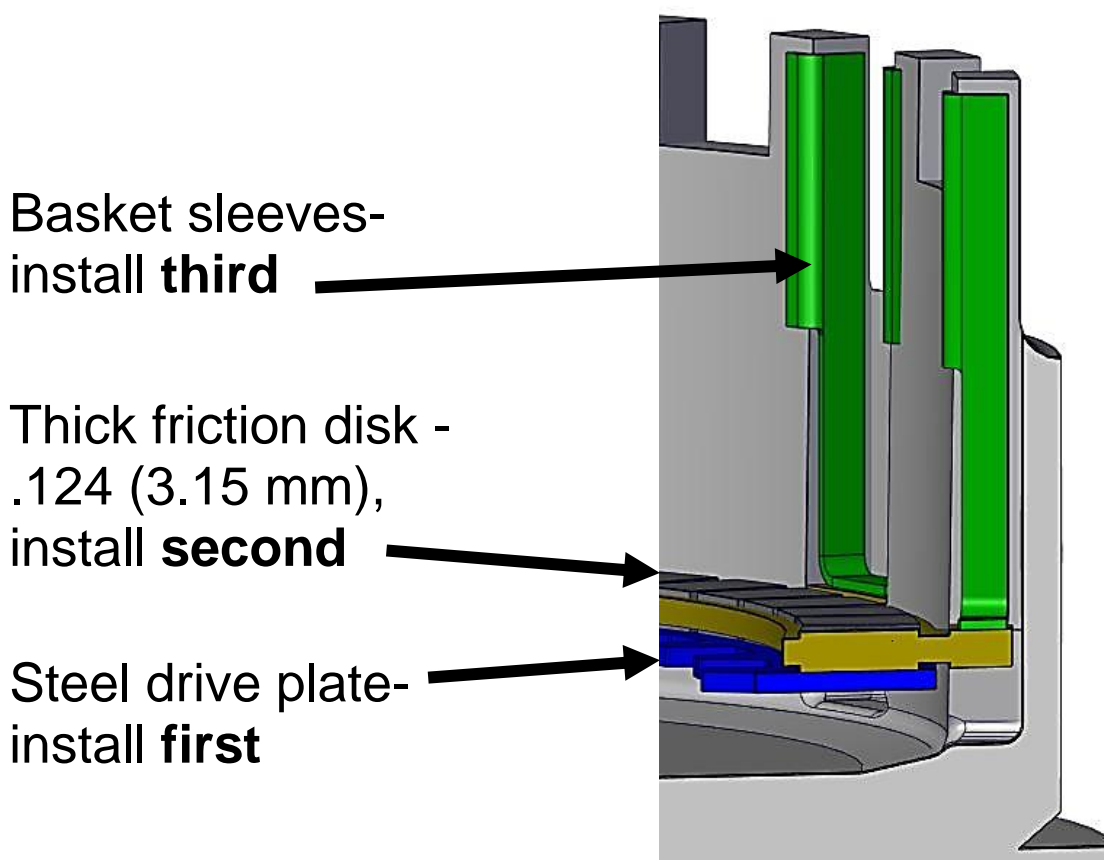

4. On top of the friction disk, install all of the Rekluse basket sleeves into the basket slots. Make sure the bottom of the sleeve is facing down, and the sleeve tabs sit against the inside of the basket. See following pictures for reference.

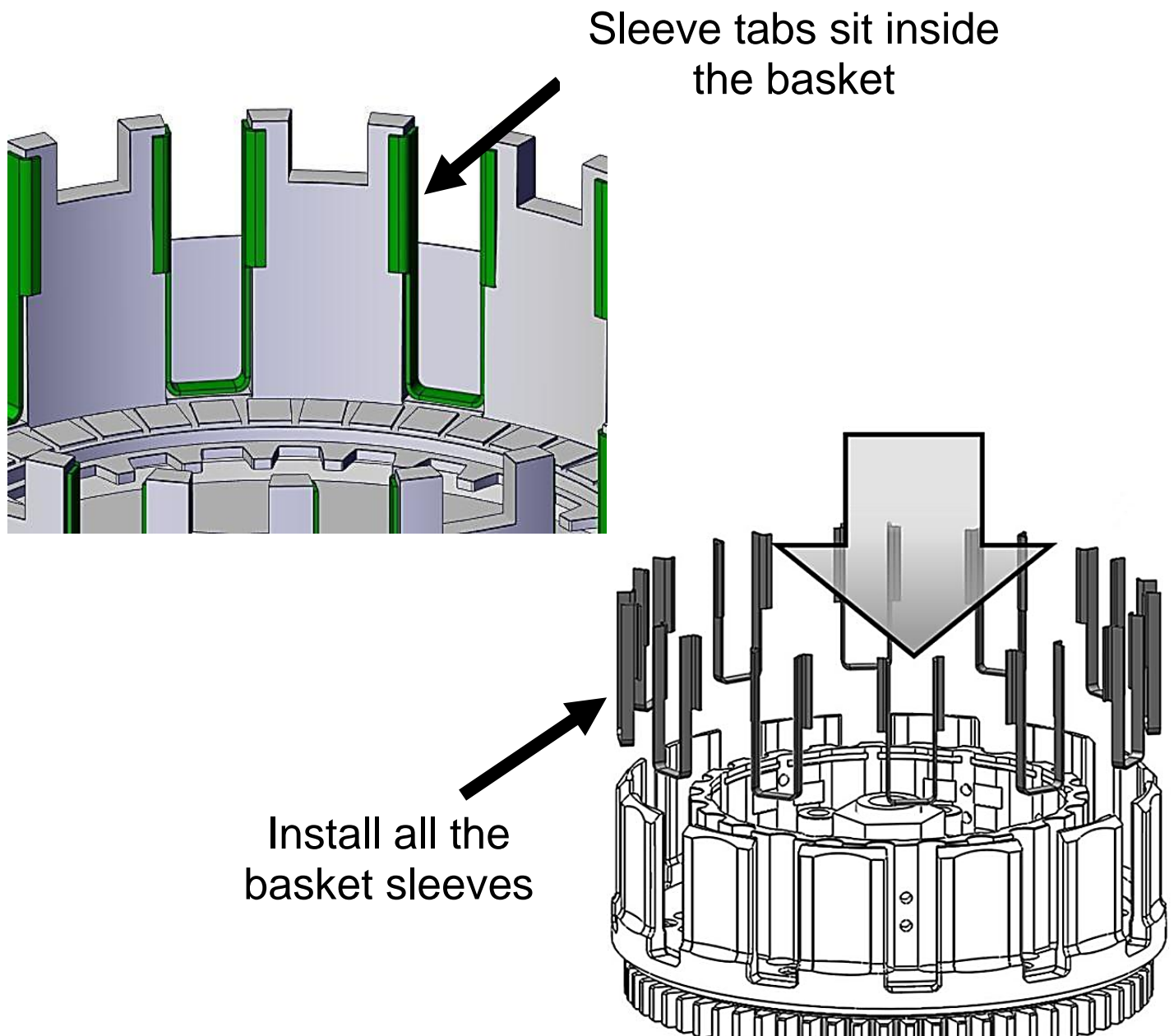

Note: When seated in the basket, the sleeve tops will sit just below the top of the basket. If the basket sleeves fall forward while installing the clutch pack, use a pick to push them back into place.

5. Alternate 10 steel drive plates with 9 thin friction disks, ending with a steel drive plate.
6. Add a notched friction disk - .137" (3.48 mm) and the last steel drive plate, then add the other notched friction disk to finish the clutch pack.

10. Reinstall the clutch cover gasket followed by the clutch cover. Ensure that the throw-out is aligned correctly with the actuator mechanism in the cover.



11. Reinstall the clutch cover bolts by lightly tightening them in a star pattern per OE specifications.
12. Torque the clutch cover bolts in small increments to 87 in-lb (9.8 N-m) per OE specifications.
13. Reinstall the left side kickstand bracket and the shift lever. Use Loctite 243 or equivalent thread-locking compound when reinstalling the kickstand.
14. Torque to OE specifications.

15. Reinstall the clutch cable to the clutch cover. Loosely thread the jam nut onto the adjuster. *It will be tightened after adjusting free play.*



16. Use the channel-lock pliers to reattach the end of the clutch cable to the actuator arm.
17. Add oil according to the OE instructions.
18. Check the clutch lever for free play.
19. Adjust free play using the threaded cable tension adjuster by the clutch cover, then tighten the jam nut.

BREAK-IN

- Break-in will occur over the first 1-2 hours of use, depending on the rider. During break-in more clutch drag may occur than normal.
- It is recommended to do an oil change after the first 1000 miles to drain any excess clutch debris that may accumulate during break-in.

TROUBLESHOOTING

Clutch Drag:

- Cold Drag Only – If drag occurs only while the bike is cold, oil is the most likely cause. Be sure to warm up the

bike before riding/racing. Use of new or lighter weight oil can help to minimize cold drag.

- Hot and Cold Drag –Check for any warped steel drive plates or frictions in the clutch pack, or other signs of wear caused by extreme heat.

Clutch Slip:

- If clutch slip occurs, inspect the clutch for signs of wear or heat.

MAINTENANCE

To keep your clutch performing at its best, perform regular maintenance on your bike and clutch. Clutch longevity and performance is greatly increased with oil quality and other bike factors that reduce engine heat.

- Inspect all of your clutch parts at regular maintenance intervals for signs wear or excessive heat, and replace components as necessary. Clutch wear is dependent on the riders use.
- Inspect and replace basket sleeves if they appear to be notched from friction disks.
- Keep up with regular oil changes as per the bike manufacturer's recommendations. Clutch performance and longevity depend on oil quality.
- For optimal clutch performance Rekluse recommends using fresh, clean oil that **meets JASO-MA** oil rating requirements.
- Repeat the break-in procedure anytime you replace the friction disks. Always soak friction disks in new oil for at least 5 minutes before installing.
- Oil recommendations can be viewed under Tech Tips on our website at <https://rekluse.com/support/videos/adventure-support-videos>.

Disk inspection examples

When inspecting the clutch pack, the following pictures can be used as a reference. **These are best viewed in color by viewing this install document at www.rekluse.com/support.**

Drive Plates – If the clutch pack is getting high amounts of heat, purple, blue, or black color can be seen on the drive plate teeth. See pictures below. Not all drive plates look the same and may look different than pictured.



Normal Heat

High Heat
(Blue)

Excessive Heat
(Black)

Friction Disks – Due to the dark color of the friction material, the friction disks will appear almost black as soon as they are put in oil. During inspection, look for glazing of the friction material. Glazing will appear shiny and feel like glass, even after oil is cleaned from the friction disk. Not all friction disks look the same and may look different than pictured.



Normal
Friction



Glazed
Friction

NEED ADDITIONAL HELP?

Website

www.rekluse.com/support

Frequently asked questions

www.rekluse.com/faq

Support Videos

www.rekluse.com/support/videos

Phone

(208) 426-0659

Technical Support

Contact Technical Support for questions related to product installation, tuning, and performance.

Hours:

Monday thru Friday: 8:00 a.m. - 5:00 p.m.

Mountain Time zone

Email: tech@rekluse.com

Customer Service

Contact Customer Service for additional product information, orders, and returns.

Hours:

Monday thru Friday: 8:00 a.m. - 5:00 p.m.

Mountain Time zone

Email: customerservice@rekluse.com

SETUP SHEET 198-2809005A

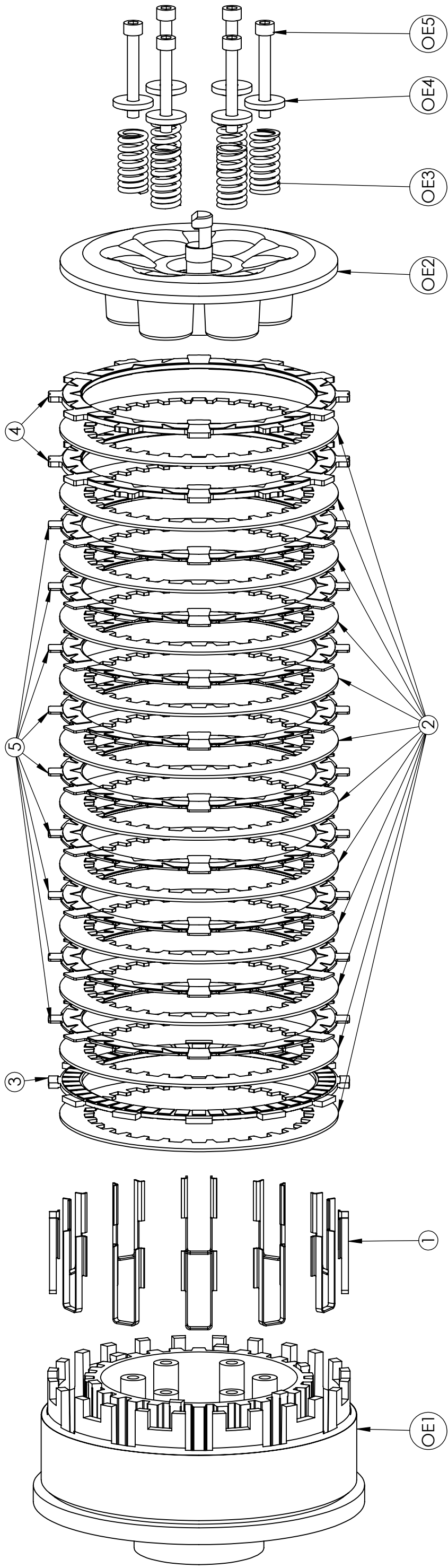

SERVICE LIMITS

COMPONENT	STANDARD	SERVICE LIMIT
TORQDRIVE FRICTION	.068-.072in 1.73-1.83mm	.065in 1.65mm
THICK TORQDRIVE FRICTION	.135-.139in 3.43-3.53mm	.132in 3.35mm
FRICTION DISK	.122-.126in 3.1-3.2mm	.119in 3.02mm

COMPONENTS

ITEM NO.	DESCRIPTION	QTY.
1	BASKET SLEEVE	12
2	REKLUSE DRIVE PLATE	12
3	FRICTION DISK 0.124"	1
4	TORQDRIVE FRICTION DISK 0.137"	2
5	TORQDRIVE FRICTION DISK 0.070"	9
OE1	OE BASKET AND HUB	1
OE2	OE PRESSURE PLATE	1
OE3	OE SPRINGS	6
OE4	OE SPRING WASHER	6
OE5	OE PRESSURE PLATE SCREW	6

CLUTCH PACK THICKNESS

