



INSTALLATION & USER'S GUIDE

TorqDrive[®] Clutch Pack
for Pull-Style, Cable Actuated Bikes

Doc ID: 191-2813A
Revision: 040819

TABLE OF CONTENTS

OVERVIEW	2
INSTALLATION TIPS	2
TOOLS NEEDED.....	4
INCLUDED PARTS	4
DISASSEMBLE THE CLUTCH	4
CLUTCH PACK INSTALLATION.....	7
Notes for clutch pack installation	7
Install Clutch Pack.....	10
CLUTCH COVER INSTALLATION.....	11
BREAK-IN.....	13
TROUBLESHOOTING.....	14
Clutch Drag	14
Clutch Slip	14
MAINTENANCE.....	14
Disk inspection examples	15
NEED ADDITIONAL HELP?.....	17

OVERVIEW

This guide shows you how to replace your OE (Original Equipment) or “stock” clutch pack with your new Rekluse TorqDrive[®] clutch pack. This clutch pack is designed specifically for your bike. The following parts are replaced:

- OE drive plates
- OE friction disks
- Pressure plate springs

INSTALLATION TIPS



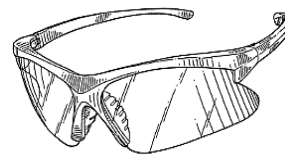

- Read the separate included **Safety Information** document before operating the vehicle with the product installed.
- Read this entire document before performing any steps.

- If you install this product for a customer or another person, instruct them to read the **Safety Information** document and the **Installation and User Guide** before operating the bike with the product.



- Protect eyes and skin – wear safety glasses and work gloves.
- Lay the motorcycle on its left side when replacing the clutch. This makes working on the clutch easier and eliminates the need to drain the oil. Catch any fuel that may drain from the bike.
- Use the torque values listed in the instructions. Otherwise, use the torque specifications found in your OE service manual.
- For optimal clutch performance Rekluse recommends using fresh, clean oil that **meets JASO-MA** oil rating requirements. Rekluse offers Factory Formulated Oil™ developed specifically for Rekluse products. Rekluse Factory Formulated Oil is a perfect complement to any OEM or aftermarket wet clutch. Visit www.rekluse.com to learn more.
- **This clutch pack is not legal to race with in the AMA Limited or Stock class.**

TOOLS NEEDED

	 8 mm	 10 mm	
Fluid Catch Container	8 mm Socket	10 mm Socket	Torque Wrench
			
Pick			

INCLUDED PARTS

The parts included in the kit depend on the bike model. See the **Setup Sheet** at the back of this manual for a list of included parts and illustration.

You can also visit our website at www.rekluse.com/support for a full parts fiche illustration and part numbers.

DISASSEMBLE THE CLUTCH

1. Soak the Rekluse friction disks in new oil for at least 5 minutes. Make sure the friction disks are coated on both sides.

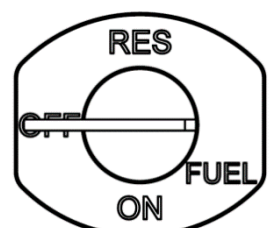
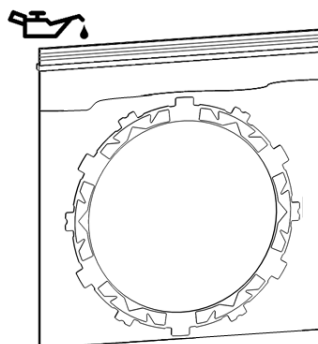

2. If applicable, turn the fuel petcock to “OFF.”

3. Lay the bike on its left side. Catch any fluids that might drain into a suitable container.

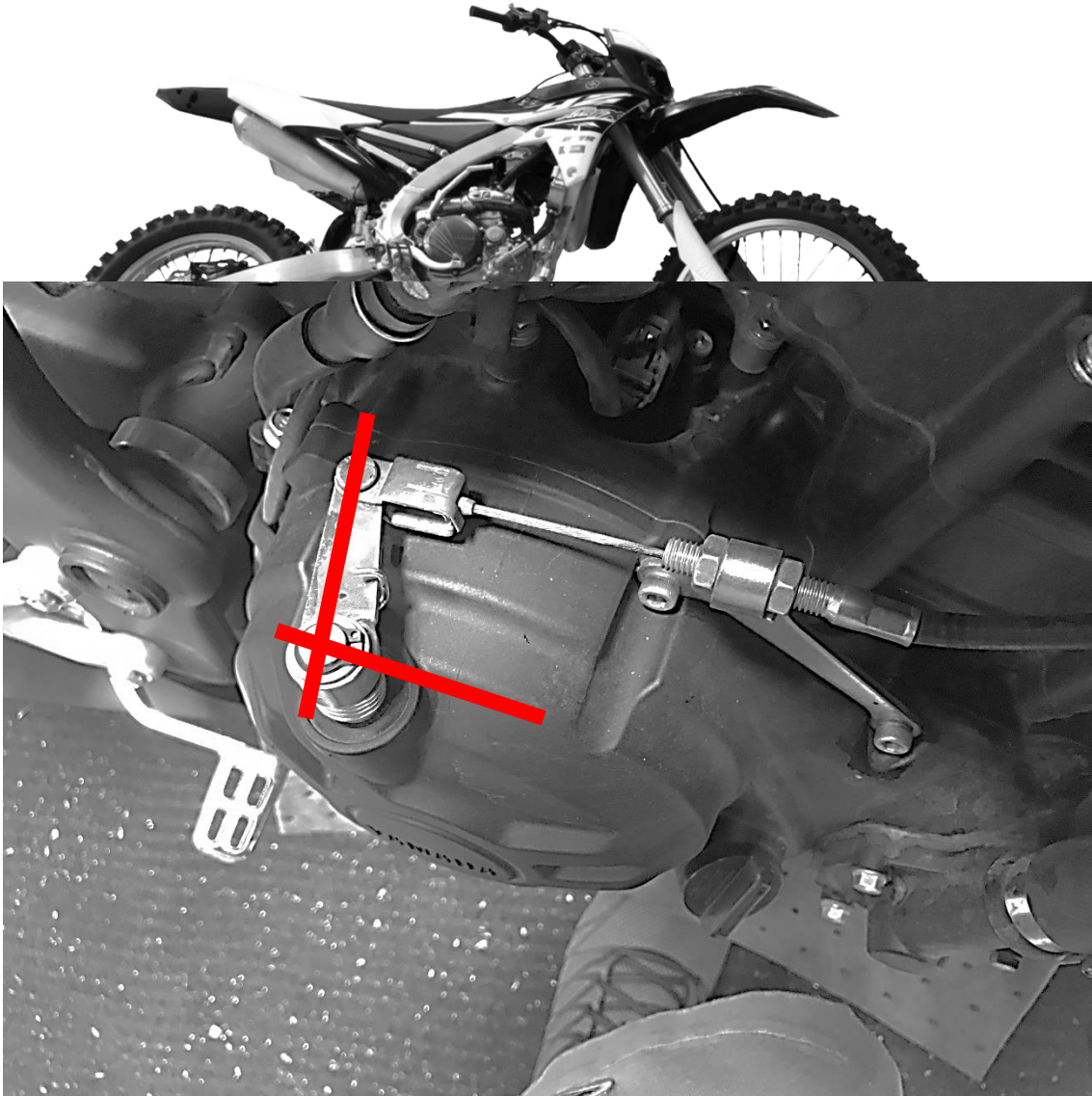

4. ***Before removing the clutch cover***, be sure to note the position of the clutch actuator arm as shown below. This is critical for adjustment. It may look slightly different than the image shown below; note the position of the actuator arm as it appears on your particular bike.

5. Remove the clutch cable from the actuator arm.

6. Remove the OE clutch cover. Set aside. It will be reused.

7. Remove the OE pressure plate bolts and springs. Set the bolts aside. They will be reused.

8. Remove the OE pressure plate and throw-out.

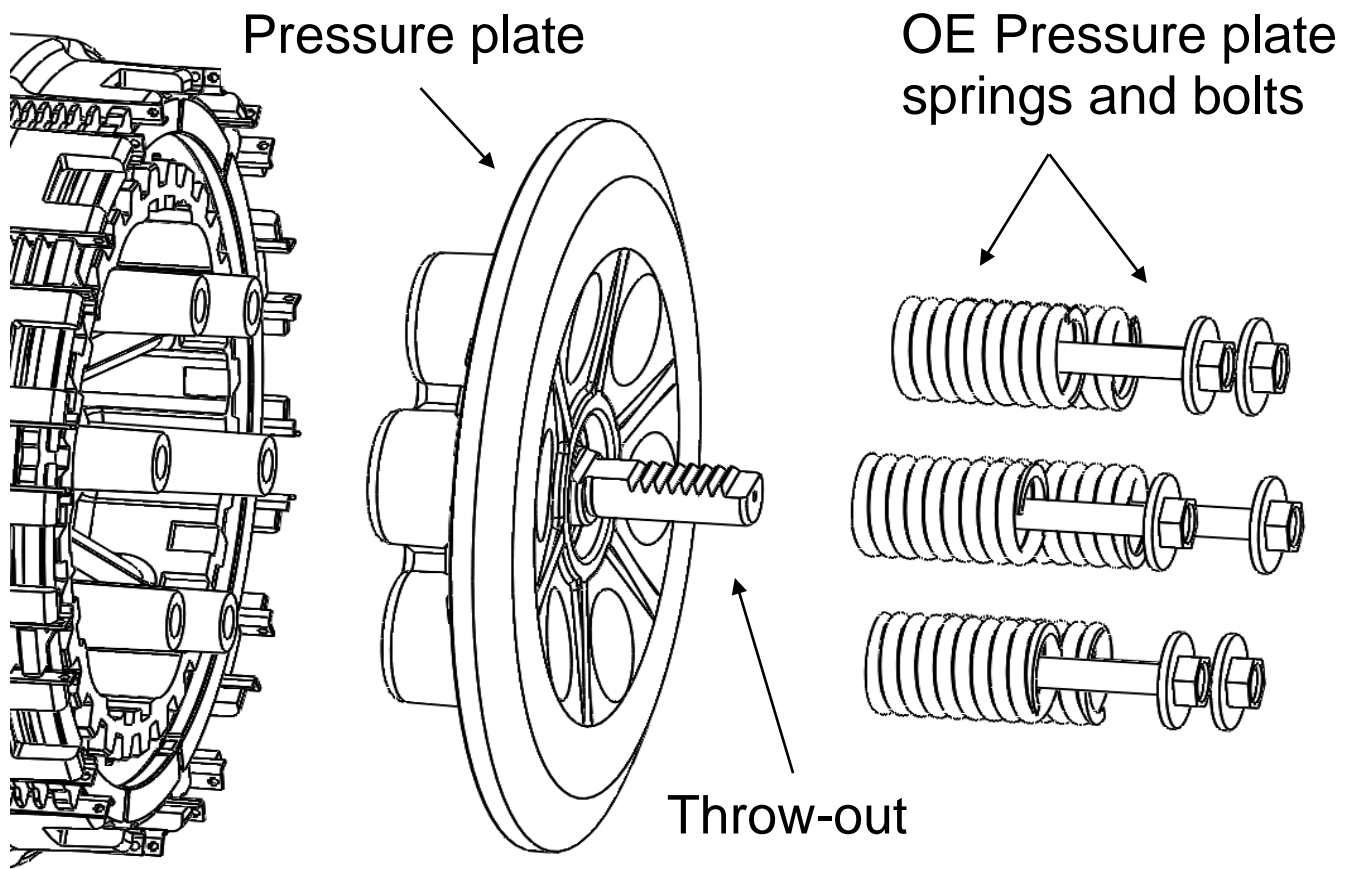

9. Remove the clutch pack.

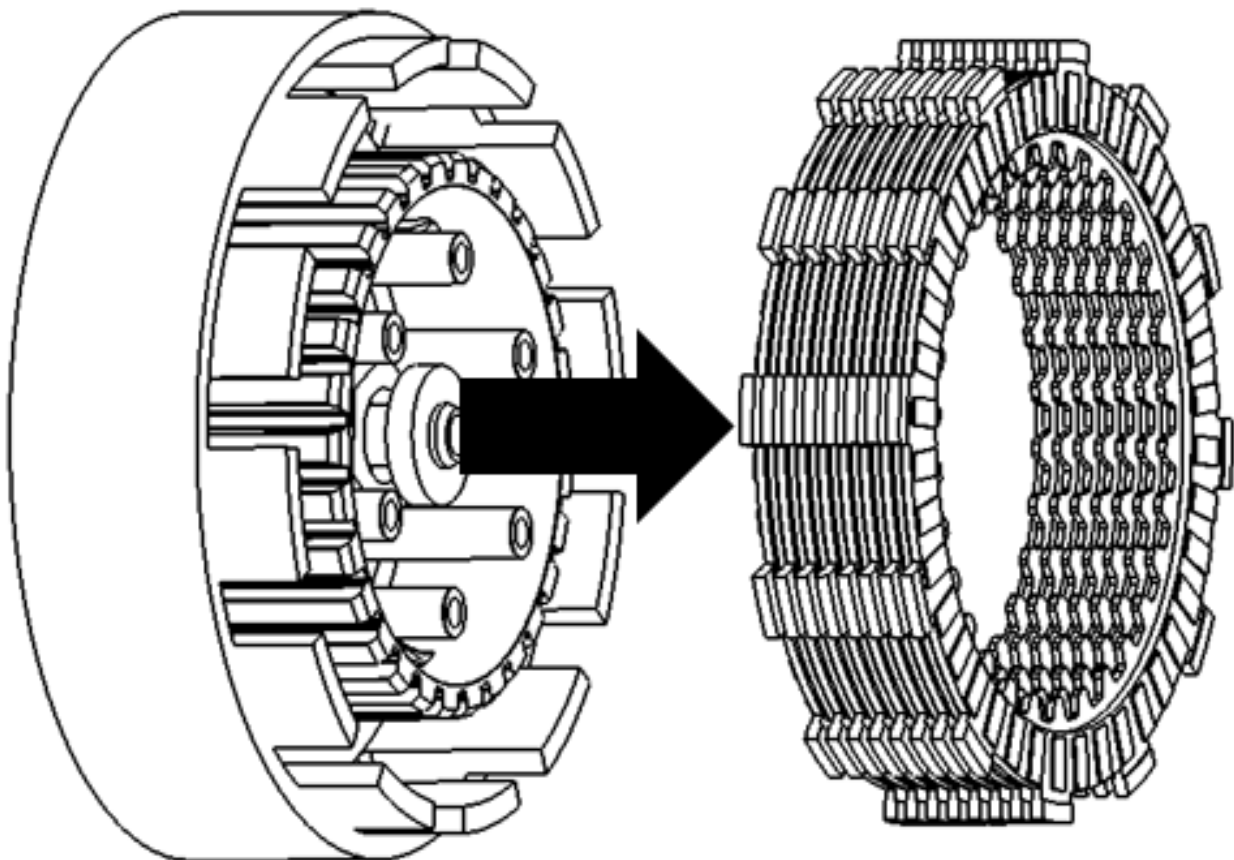

Note: Some models have a clutch boss spring located in the bottom of the OE friction pack. This consists of a spring, seat and narrow friction. If your bike is equipped with these parts, remove them and set them aside. Only some models will reuse the spring. See setup sheet.

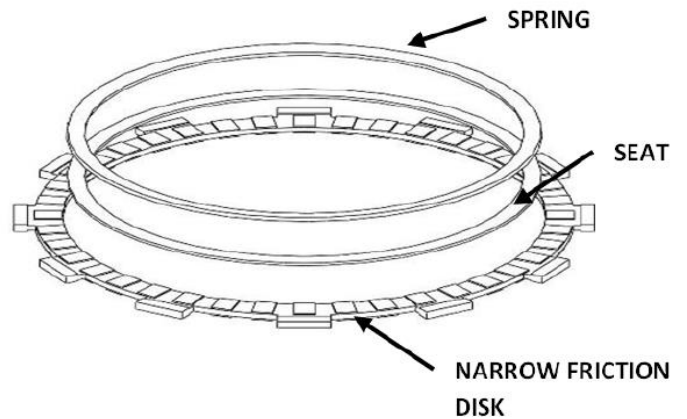

CLUTCH PACK INSTALLATION

Notes for clutch pack installation

- Some friction disks are marked with a small colored dot. This mark is used for processing and can be ignored.
- Some OE basket have “half slots” at the top of the basket tangs. Rekluse products require the entire clutch pack be installed into the MAIN (deeper) basket slots. Do not use the “half slots.” See the following picture for reference.



- *Inspect the clutch basket for damper and/or spring play. Inspect the clutch basket for notching. Do not install sleeves or use product with a notched basket. Notched basket tang faces can cause the sleeves to break. Do not use baskets that have been filed, machined, or modified on the tangs. Replace basket if necessary.*

⚠ WARNING

Failure to inspect the basket and replace if necessary could result in death, serious injury, and/or property damage.

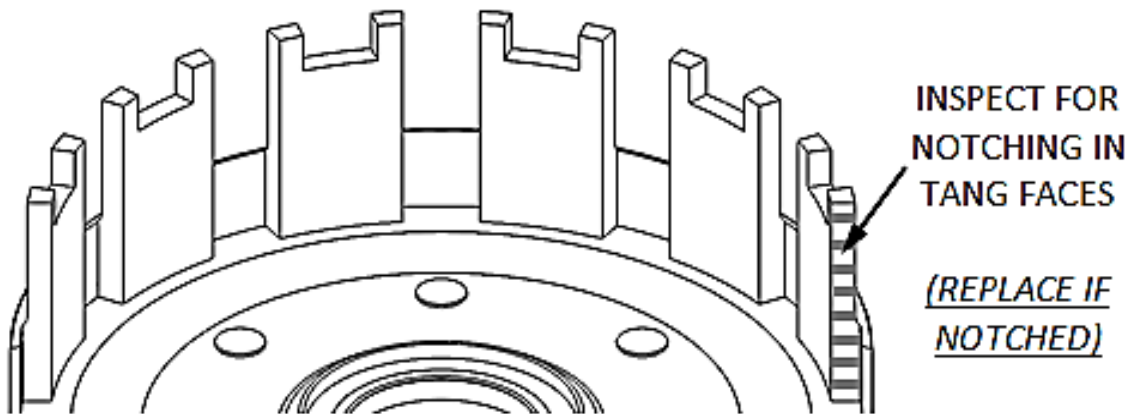

Note: *If the basket is notched or worn, Rekluse recommends replacing it with a Rekluse Billet Clutch Basket (available for most models).*



- *Inspect your OE center hub and pressure plate flanges for excess wear. If wear is visible use a drop gauge to verify that the wear across the flange does not exceed .005" (.12mm).*

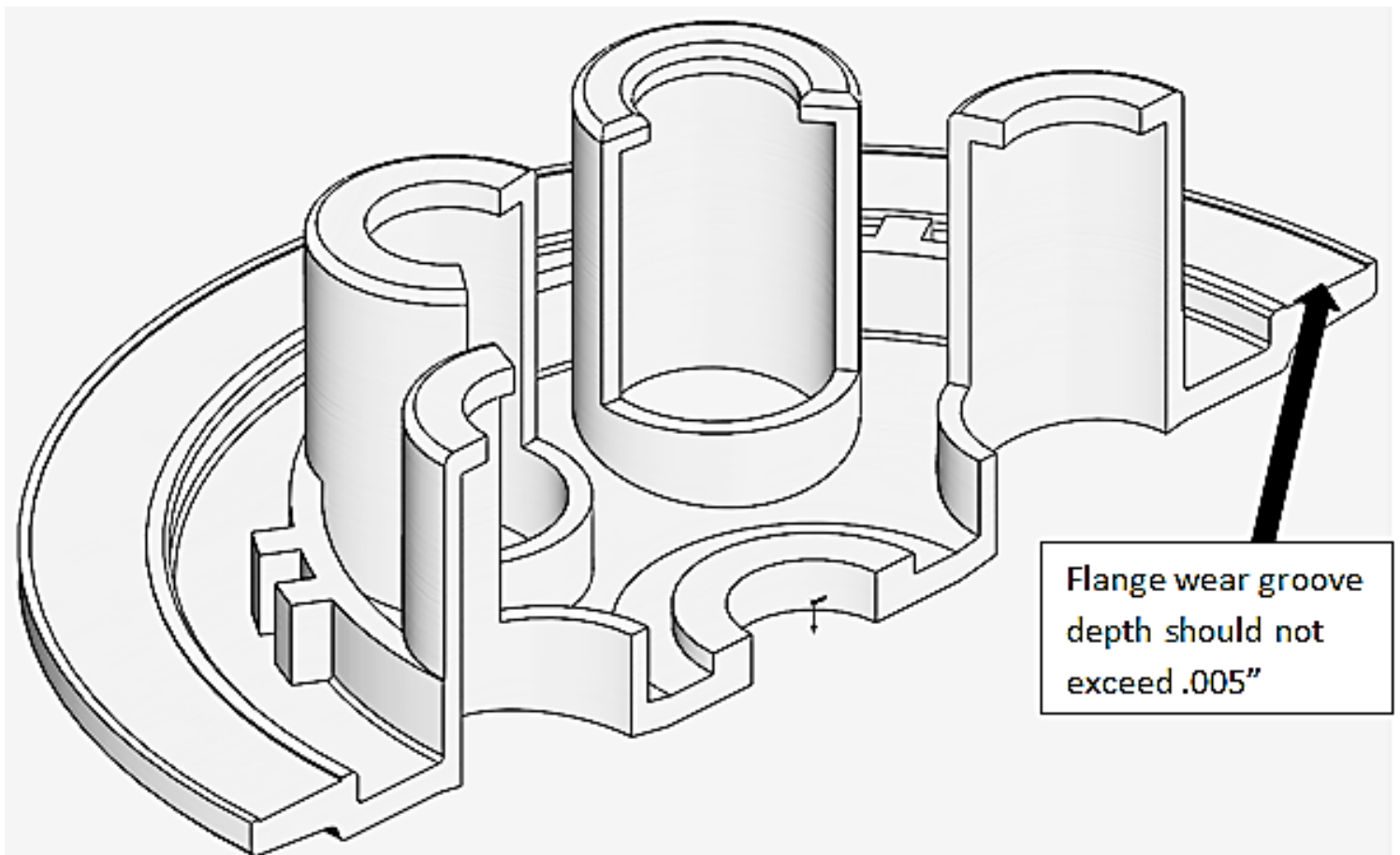
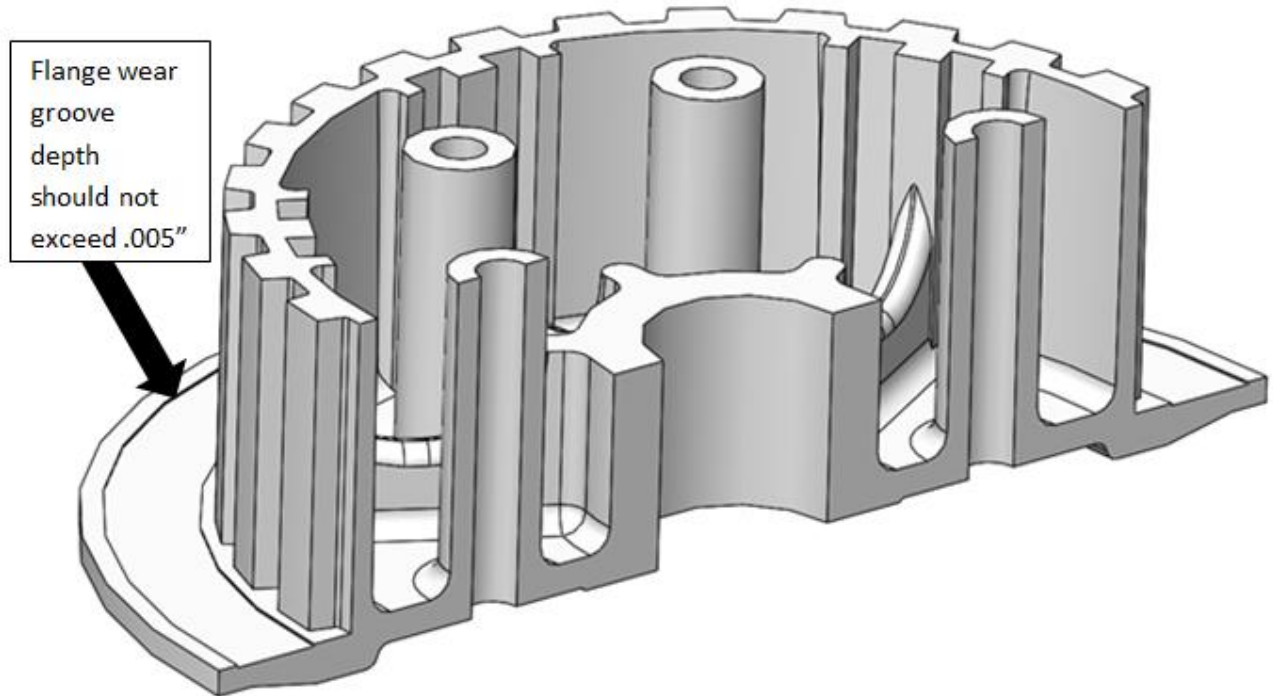

Install Clutch Pack

1. Install all of the Rekluse basket sleeves into the basket slots. Make sure the bottom of the sleeve is facing down, and the sleeve tabs sit against the inside of the basket. See following pictures for reference.

Sleeve tabs sit inside the basket

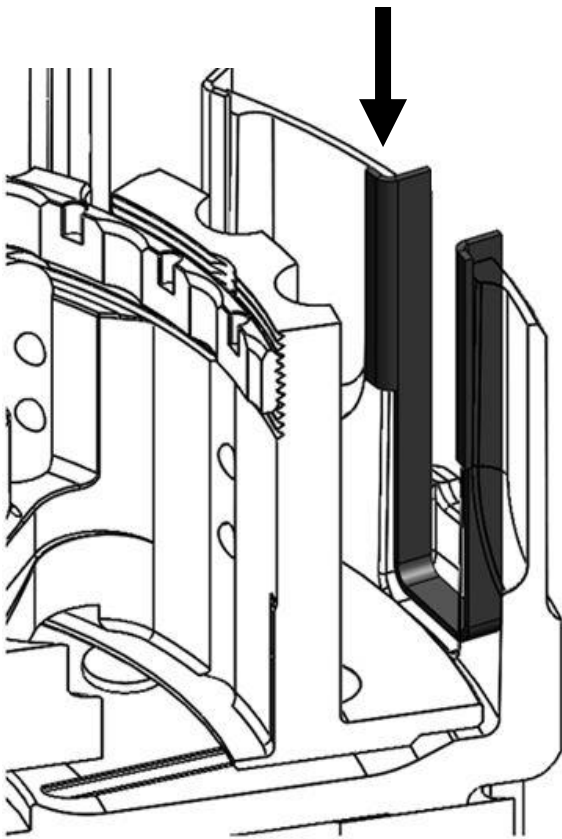

Install all the basket sleeves

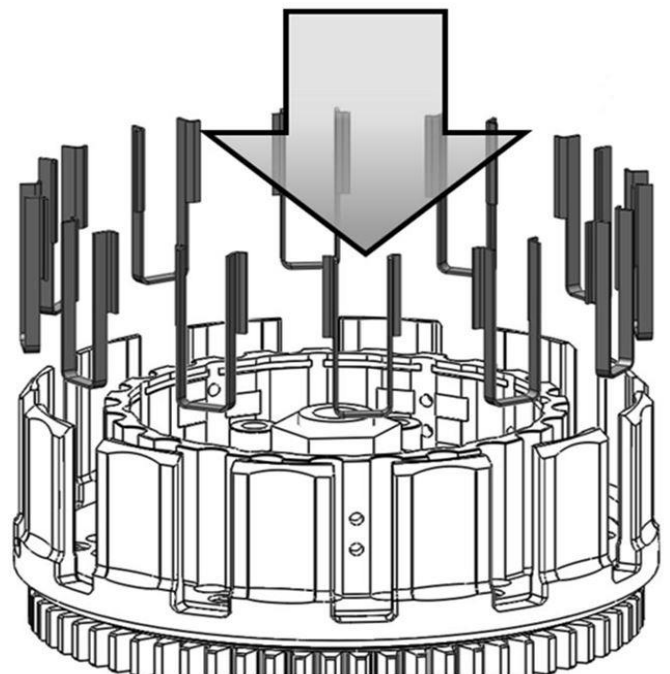

Note: When seated in the basket, the sleeve tops may sit slightly above or below the top of the basket.

2. Install the Rekluse clutch pack. The clutch pack varies depending on the bike model. **See the Setup Sheet located at the back of the manual for the proper clutch pack configuration.**

Note: If the **Setup Sheet** shows that your bike model reuses the judder spring, reinstall only the judder spring, cupped side up.

3. Reinstall the throw-out and pressure plate, then install the Rekluse pressure plate springs and OE bolts.

Note: *If the clutch kit includes 2 different colors of springs, be sure to alternate the springs. This will ensure even pressure on the clutch.*

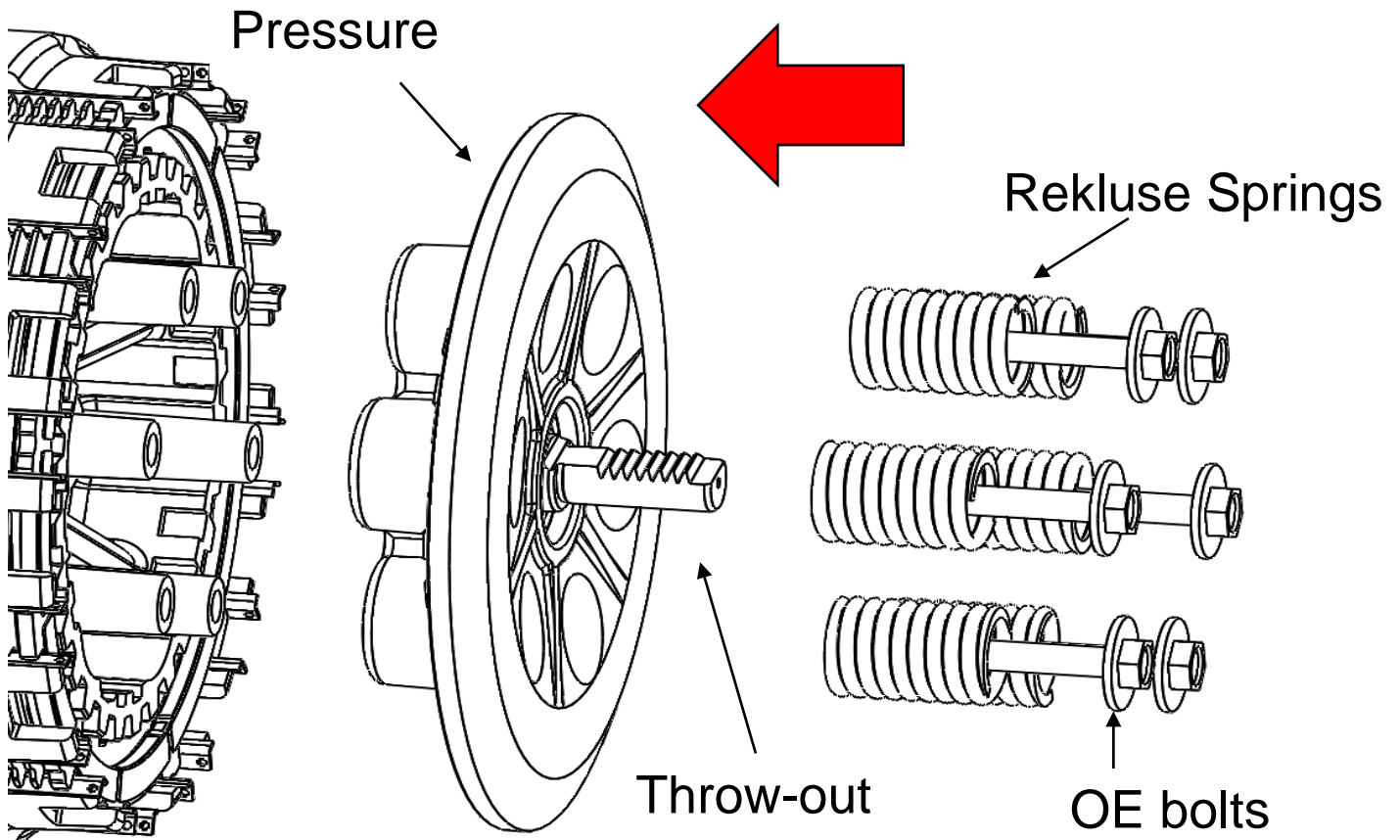

4. Torque the pressure plate bolts in small increments in a star pattern to OE specifications.

CLUTCH COVER INSTALLATION

Before securing the clutch cover in place or reattaching the clutch cable bracket to the engine, follow the next steps to achieve the correct actuator arm orientation to ensure adequate cable travel during use.

Note: The clutch actuation mechanism is a rack and pinion system. Because there is limited cable adjustment at the in-line cable adjuster, you will be performing the major adjustment at the actuator shaft (pinion gear).

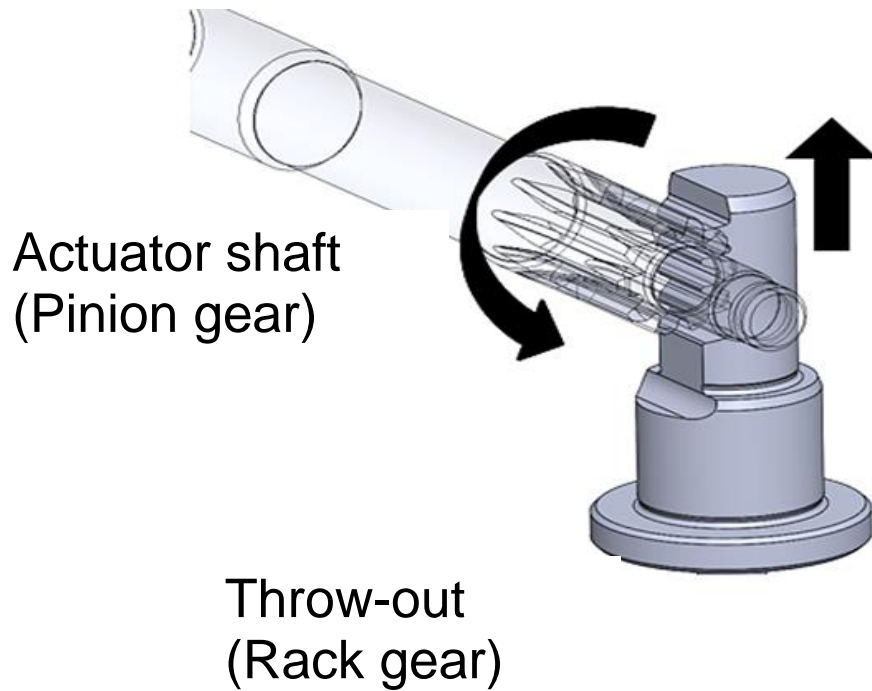

1. Align the teeth on the throw-out with the actuator shaft in the clutch cover, then hold the clutch cover in place on the clutch.



2. The actuator arm should be aligned so that when the cable is reattached the arm is in the position that was noted before installation.
 - a. If the actuator arm is in the correct position, continue with the step 3.
 - b. If the actuator arm is not in the correct position, gently pull the cover off and move the actuator shaft one gear tooth on the throw-out. Replace the clutch cover and recheck the actuator arm position.
3. When the actuator arm is in the correct position, lightly tighten the cover bolts in a star pattern. Torque the bolts in small increments before tightening all the bolts to OE specifications.
4. Reattach the clutch cable to the actuator arm.
5. Adjust the stock lever free play to OE specification or **10-20 mm (.4 -.8 in)**.
5. Adjust lever free play using the in-line cable adjuster and the perch adjuster.

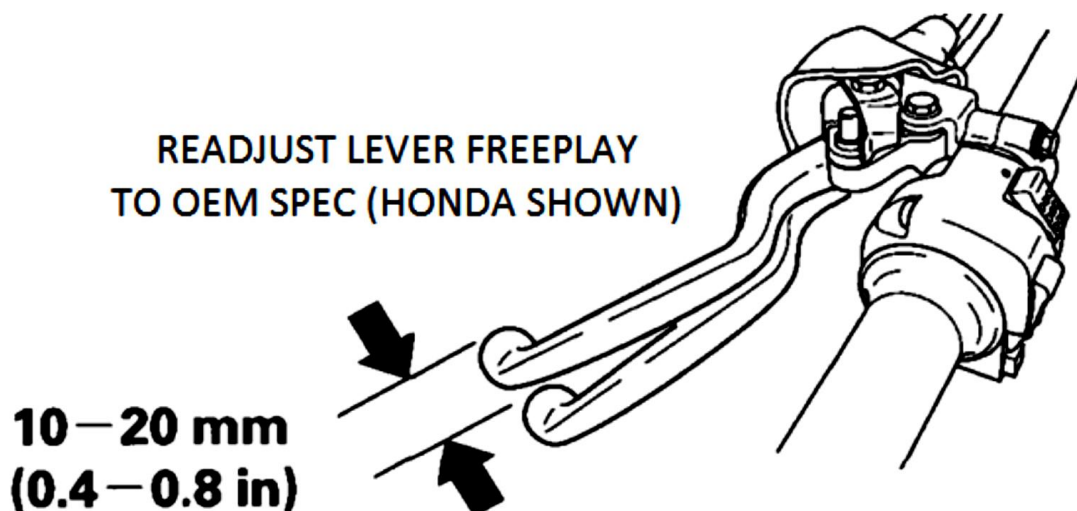

BREAK-IN

- Break-in will occur over the first 1-2 hours of use, depending on the rider. During break-in more clutch drag may occur than normal.

- It is recommended to do an oil change after 1-2 hours of riding to drain any excess clutch debris that occurred from break-in.

Note: 4 strokes only: It is normal for some clutch debris to be produced during break in. Following break-in, remove and inspect the OE oil filter. Clean or replace it if necessary. Remove and inspect any additional oil screens for clutch debris and clean or replace if necessary.

TROUBLESHOOTING

Clutch Drag:

- Cold Drag Only – If drag occurs only while the bike is cold, oil is the most likely cause. Be sure to warm up the bike before riding/racing. Use of new or lighter weight oil can help to minimize cold drag.
- Hot and Cold Drag –Check for any warped steel drive plates or frictions in the clutch pack, or other signs of wear caused by extreme heat.

Clutch Slip:

- If clutch slip occurs, inspect the clutch for signs of wear or heat.
- Check clutch lever free play.

MAINTENANCE

Rekluse clutches are built using high quality materials but do wear based on the rider's use, type of terrain, and natural wear and tear. Clutch longevity and performance is greatly increased with clean oil and other bike factors that reduce engine heat.

- Check clutch lever free play.
- Inspect all of your clutch parts at regular maintenance intervals for signs wear or excessive heat, and replace

components as necessary. Clutch wear is dependent on the riders use.

- Inspect and replace basket sleeves if they appear to be notched from friction disks.
- Keep up with regular oil changes as per the bike manufacturer's recommendations. Clutch performance and longevity depend on clean oil.
- For optimal clutch performance Rekluse recommends using fresh, clean oil that **meets JASO-MA** oil rating requirements.
- Repeat the break-in procedure anytime you replace the friction disks. Always soak friction disks in new oil for at least 5 minutes before installing.

Disk inspection examples

When inspecting the clutch pack, the following pictures can be used as a reference. **These are best viewed in color by viewing this install document at www.rekluse.com/support.**

Drive Plates – If the clutch pack is getting high amounts of heat, purple, blue, or black color can be seen on the drive plate teeth. See pictures below. Not all drive plates look the same and may look different than pictured.



Normal Heat

High Heat
(Blue)

Excessive Heat
(Black)

Friction Disks – Due to the dark color of the friction material, the friction disks will appear almost black as soon as they are put in oil. During inspection, look for glazing of the friction material. Glazing will appear shiny and feel like glass, even after oil is cleaned from the friction disk. Not all friction disks look the same and may look different than pictured.



Normal
Friction



Glazed
Friction

NEED ADDITIONAL HELP?

Website

www.rekluse.com/support

Frequently asked questions

www.rekluse.com/faq

Support Videos

www.rekluse.com/support/videos

Phone

(208) 426-0659

Technical Support

Contact Technical Support for questions related to product installation, tuning, and performance.

Hours:

Monday thru Friday: 8:00 a.m. - 5:00 p.m.

Mountain Time zone

Email: tech@rekluse.com

Customer Service

Contact Customer Service for additional product information, orders, and returns.

Hours:

Monday thru Friday: 8:00 a.m. - 5:00 p.m.

Mountain Time zone

Email: customerservice@rekluse.com



SETUP SHEET 198-2807090

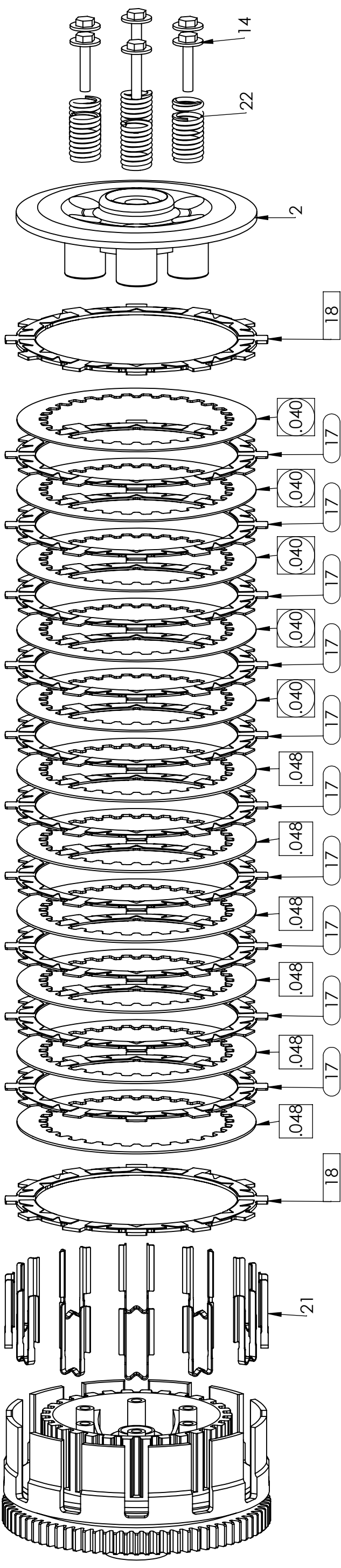

ITEM NO.	DESCRIPTION	QTY.
2	STOCK PRESSURE PLATE	1
14	STOCK SPRING BOLT	6
17	TORQDRIVE FRICTION DISC	10
18	THICK FRICTION DISC	2
.048	REKLUSE DRIVE PLATE (.048")	6
.040	REKLUSE DRIVE PLATE (.040")	5
21	REKLUSE BASKET SLEEVE	12
22	REKLUSE CLUTCH SPRING	6

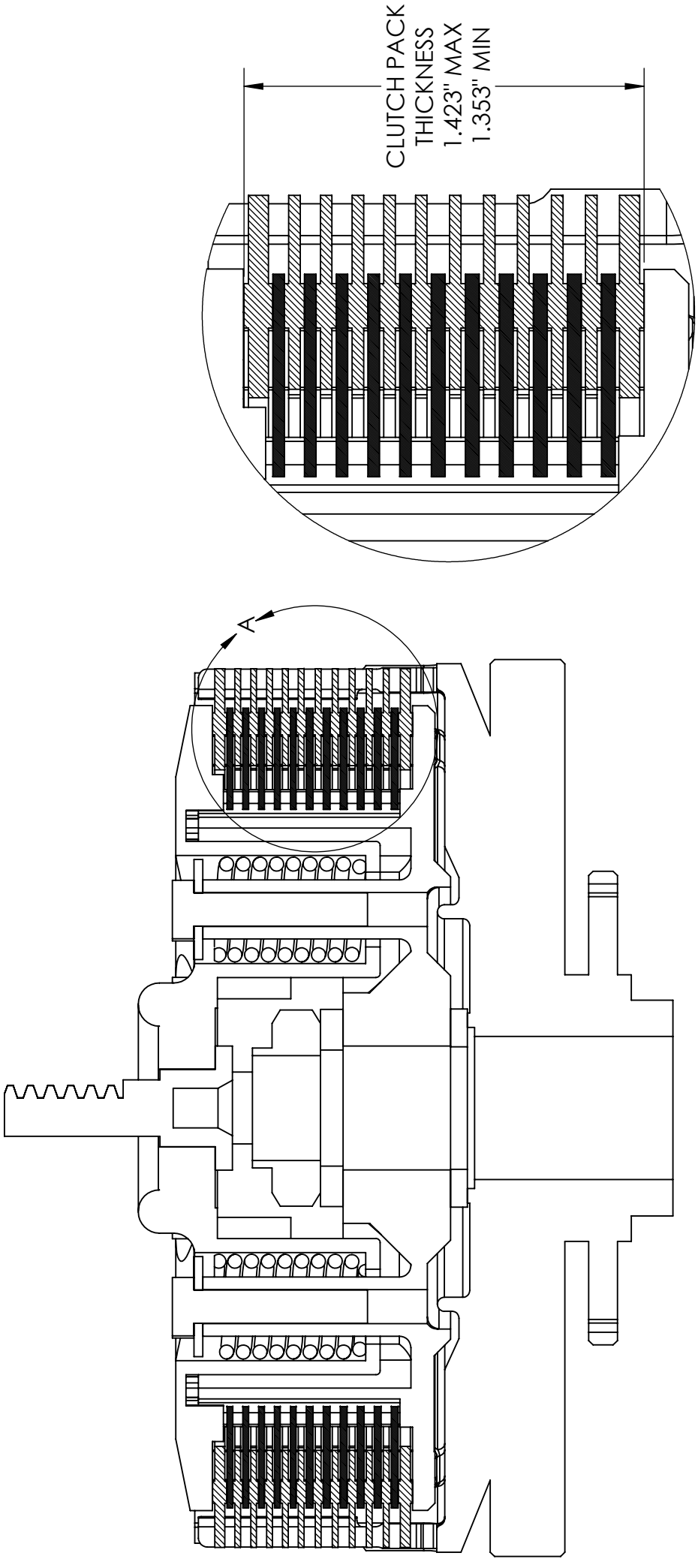

DETAIL A
SCALE 2 : 1