



INSTALLATION & USER'S GUIDE

For Yamaha YZF-R7

Doc ID: 191-2807012A
Revision: 070522

TABLE OF CONTENTS

OVERVIEW.....	2
INSTALLATION TIPS.....	3
USE OF OTHER AFTERMARKET PRODUCTS	4
TOOLS NEEDED	4
RECOMMENDED PARTS	4
DISASSEMBLE THE CLUTCH	5
CLUTCH PACK INSTALLATION	8
Notes for clutch pack installation	8
CLUTCH COVER INSTALLATION	11
BREAK-IN	14
TROUBLESHOOTING	15
MAINTENANCE	15
Disk inspection examples	16
NEED ADDITIONAL HELP?	17

OVERVIEW

This guide shows you how to replace your OE (Original Equipment) or “stock” clutch parts with your new clutch pack.

- This kit will replace all the OE frictions and drive plates with a Rekluse TorqDrive[®] clutch pack and EXP disk.
- The OE pressure plate springs are replaced with high quality Rekluse springs.

INSTALLATION TIPS

- Read the separate included Safety Information document before operating the vehicle with the product installed.
- Read this entire document before performing any steps.
- If you install this product for a customer or another person, instruct them to read the **Safety Information** document and the **Installation and User Guide** before operating the bike with the product.
- Protect eyes and skin – wear safety glasses and work gloves.
- Use the torque values listed in the instructions. Otherwise, use the torque specifications found in your OE service manual.
- For optimal clutch performance Rekluse recommends using fresh, clean oil that **meets JASO-MA** oil rating requirements. Rekluse offers Factory Formulated Oil™ developed specifically for Rekluse products. Rekluse Factory Formulated Oil is a perfect complement to any OEM or aftermarket wet clutch. Visit www.rekluse.com to learn more.

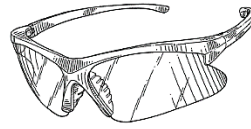

USE OF OTHER AFTERMARKET PRODUCTS

- If your bike is equipped with an aftermarket clutch cable, you may find that the adjustment range in your cable is different than depicted in this manual.
- If you prefer the use of an aftermarket clutch lever and/or perch, especially the adjustable variety, note that:
 - Some aftermarket lever/perch combos claim “Lighter Lever Pull” which correlates to less lift of the pressure plate. This may produce more clutch drag or harder shifts. The lever may be lighter, but you will have to pull the lever in farther to disengage the clutch.
 - Some aftermarket lever/perch combos may provide lever “free play” if desirable.

TOOLS NEEDED

- Fluid catch container
- Dental picks
- Metric wrench set
- Torque wrench
- Metric hex key set
- Channel-lock pliers
- Needle-nose pliers

RECOMMENDED PARTS

Rekluse recommends installing a new OE clutch cover gasket when reinstalling the clutch cover. This can be purchased from your local dealer.

Visit www.rekluse.com/support for a full parts fiche illustration and part numbers.

DISASSEMBLE THE CLUTCH

1. Soak the TorqDrive® friction disks in engine oil for 5 minutes.
2. Stand the bike on a suitable bike stand and remove the right side cowlings to access the radiator cap and clutch cover.

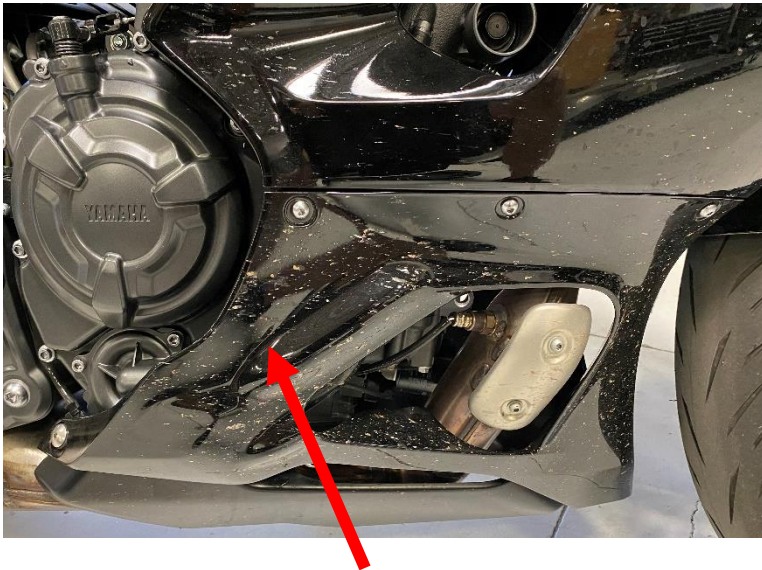
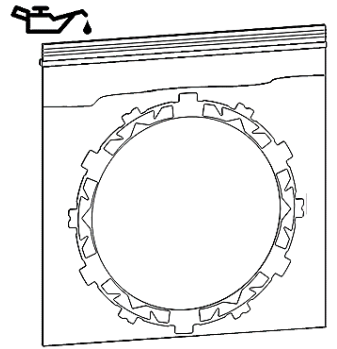

One Lower panel

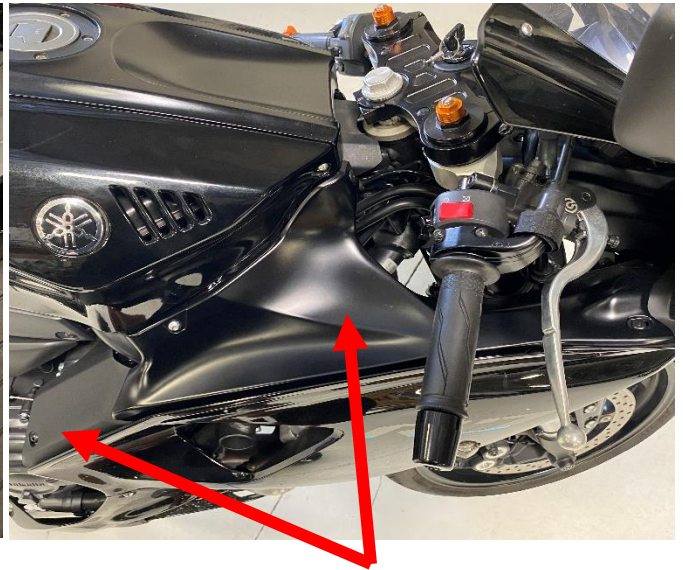

Two Upper panels

3. Drain the coolant into suitable containers.
4. Use a hex key to remove the water pump cover. (The cover can be pulled back and held with a strap to keep it out of the way during installation.)

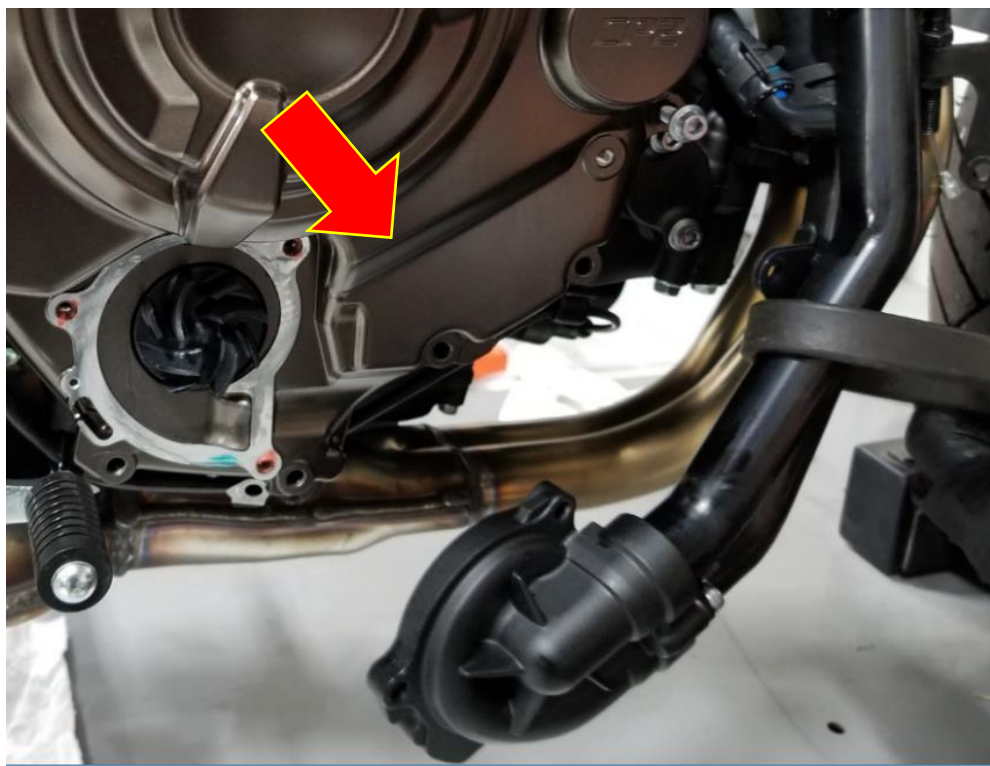

5. Using the in-line cable adjuster, loosen the tension in the clutch cable so that the lever becomes sloppy at the perch.
6. Use a hex key to remove the actuator arm bracket and move it to the side.

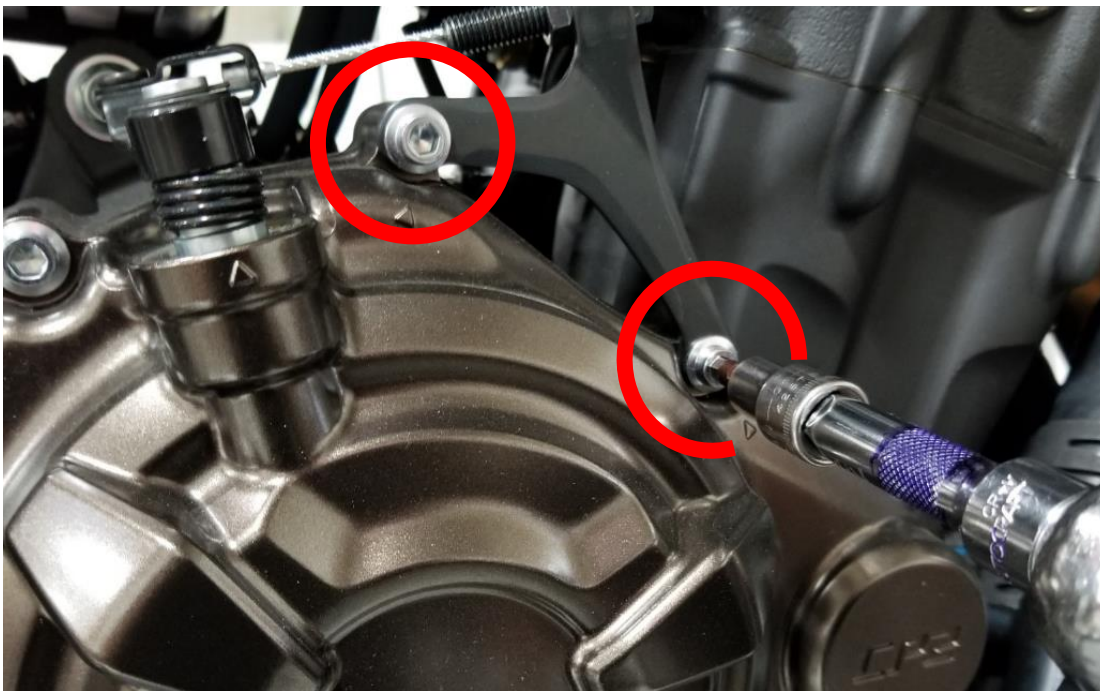

7. Bend up the tab on the clutch actuator arm and unhook the clutch cable.



8. Use a 5 mm hex key to remove the clutch cover bolts.

9. Remove the clutch cover and gasket. Set these aside. They will be reused. If the gasket is damaged when removed, you will need to purchase a new one.

Note: Rekluse recommends installing a new OE clutch cover gasket when reinstalling the clutch cover.

Note: Do not move the water pump components in the cover or case out of position as they will need to mate back together during installation.

10. Remove the OE pressure plate bolts, spring ring, springs, pressure plate, and OE clutch pack.

Note: The pressure plate, throw out, spring ring, and bolts will be reused.

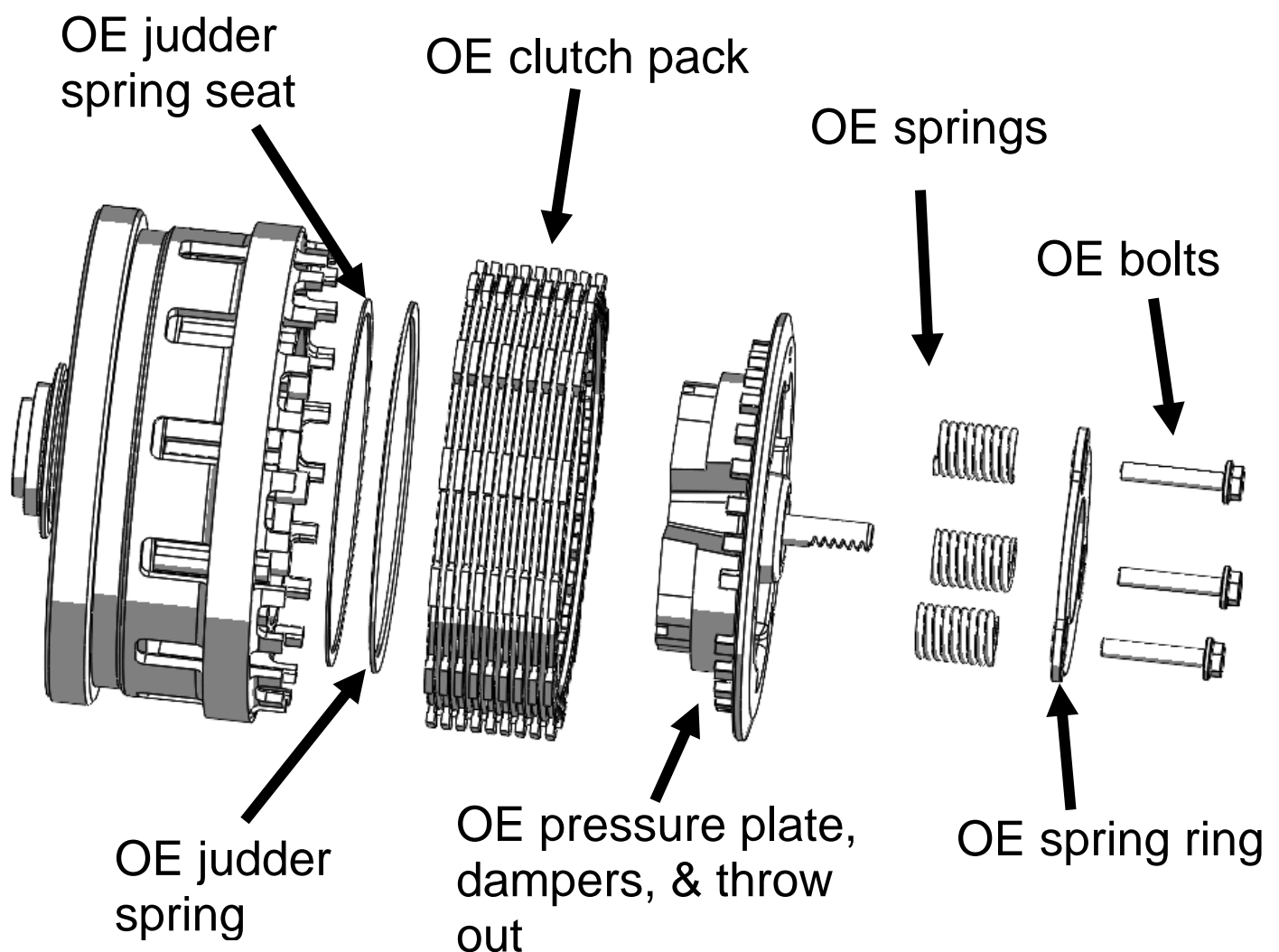

CLUTCH PACK INSTALLATION

1. Inspect the clutch basket for notching. Do not install sleeves or use product with a notched basket. Notched basket tang faces can cause the sleeves to break.

⚠ WARNING

Failure to inspect the basket and replace if necessary could result in death, serious injury, and/or property damage.

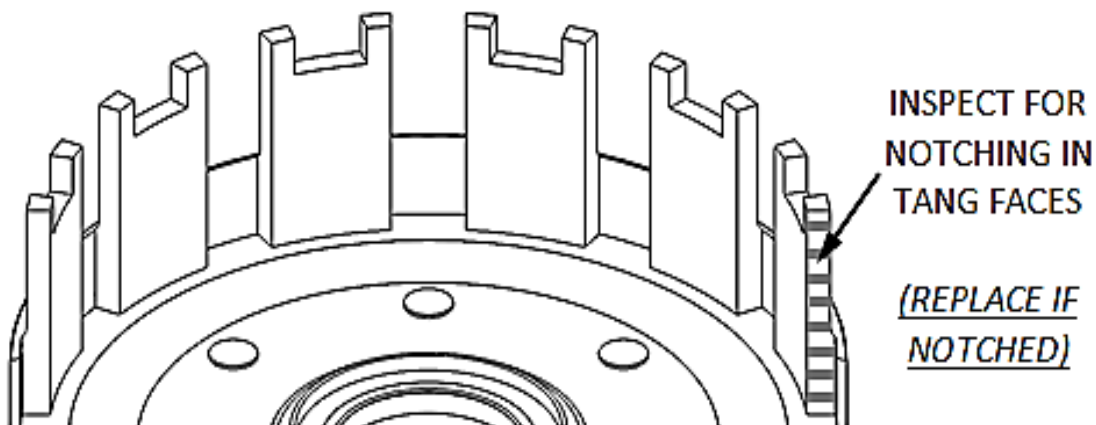

Notes for clutch pack installation

- *Some friction disks are marked with a small colored dot. This mark is used for processing and can be ignored.*
- *Some OE basket have “half slots” at the top of the basket tangs. Rekluse products require the entire clutch pack be installed into the MAIN (deeper) basket slots. Do not use the “half slots.” See the following picture for reference.*



2. Install all of the Rekluse basket sleeves into the basket slots. Make sure the bottom of the sleeve is facing down, and the sleeve tabs sit against the inside of the basket. See pictures for reference.

Note: *When seated in the basket, the sleeve tops will sit flush or just below flush with the top of the basket.*

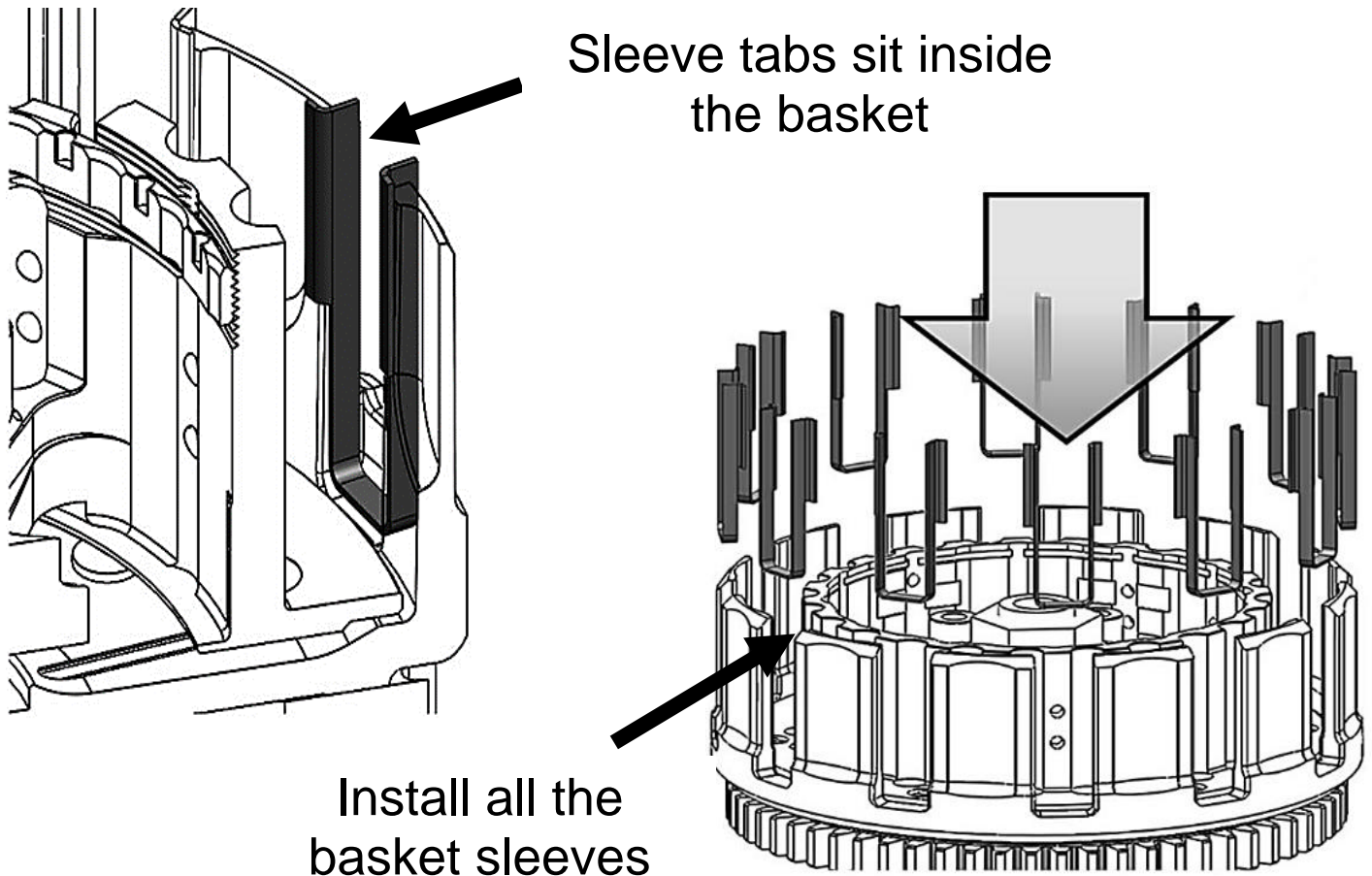

⚠ WARNING

Rekluse basket sleeves are designed to be installed into an OE or Rekluse clutch basket ONLY. The use of non-Rekluse aftermarket clutch baskets may cause clutch damage or failure.

3. Refer to the setup sheet at the back of the manual for the order the clutch pack frictions and drive plates are installed.

4. Turn the pressure plate over onto a work bench. Place the one .130" thick friction disk on to the pressure plate.
5. Next place the .060" drive plate on to the pressure plate and place the last .130" thick friction disk.



6. Reinstall the OE pressure plate assembly with the throw out.

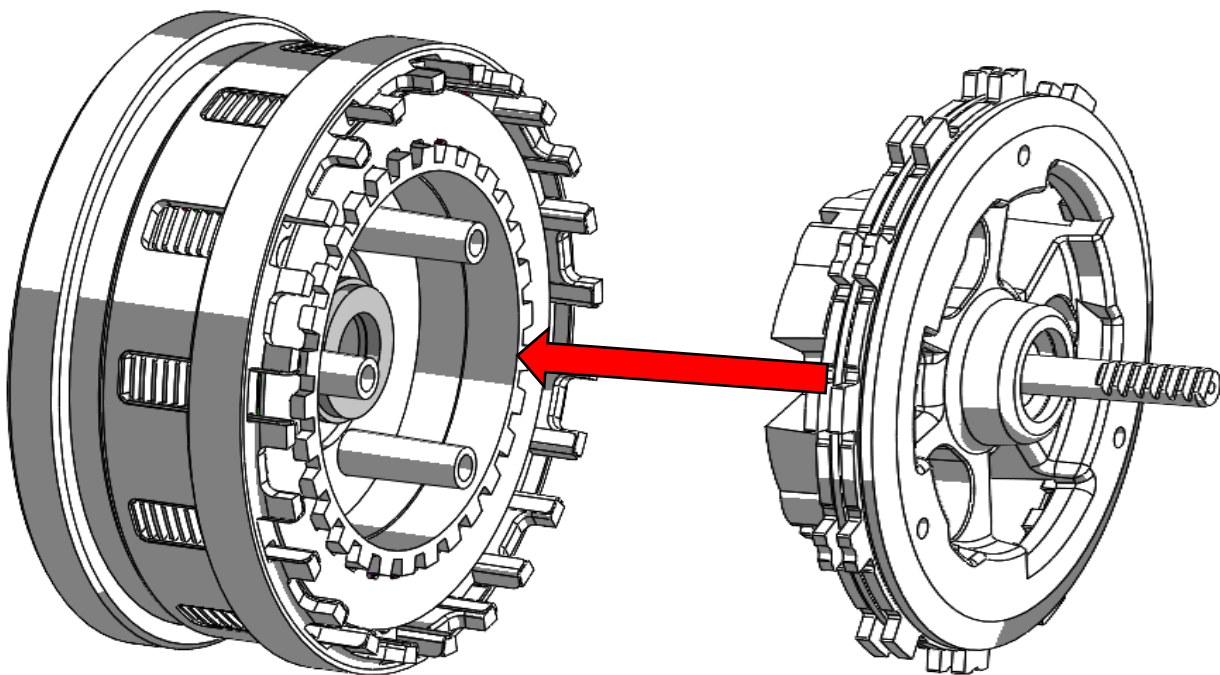

7. Install the pressure plate springs, spring ring, and bolts. Tighten the bolts evenly to OE specifications.

CLUTCH COVER INSTALLATION

Before securing the clutch cover in place or reattaching the clutch cable to the actuator arm, follow the next steps to achieve the correct actuator arm orientation to ensure adequate cable travel during use.

Note: *The clutch actuation mechanism is a rack and pinion system. Because there is limited cable adjustment at the in-line cable adjuster, you will be performing most of the adjustment at the actuator shaft (pinion gear).*

1. Reinstall the OE clutch cover gasket (or new OE gasket) on the clutch cover.
2. Align the teeth on the throw-out with the actuator shaft in the clutch cover, then push the clutch cover into place over the clutch until it is snug against the engine case.

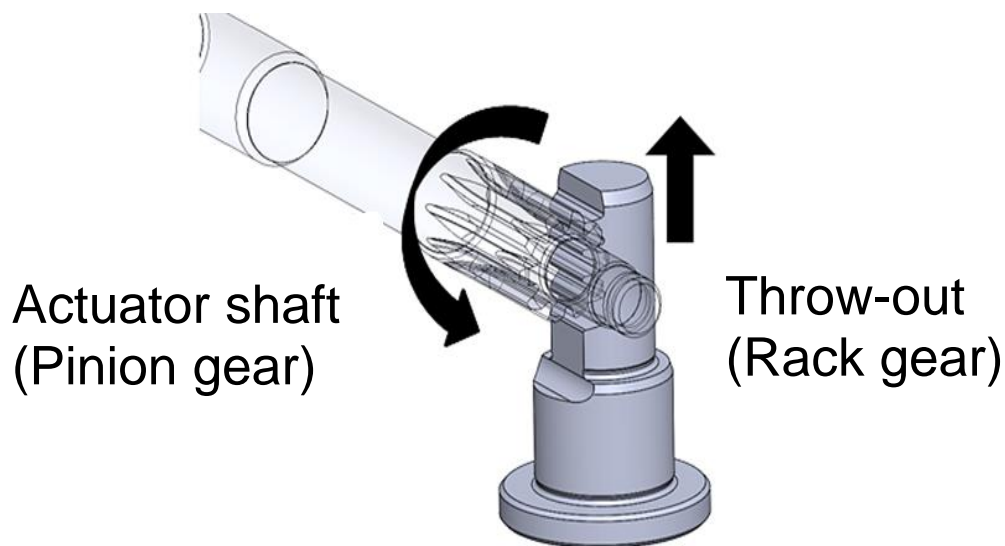

3. Check that the actuator arm position is close to perpendicular with the clutch cable. Lightly tighten the cover bolts to hold the cover in place.

Note: If the actuator arm is not perpendicular to the cable, There are two ways to adjust it:

- a) Gently pull the cover off and move the actuator shaft one gear tooth on the throw-out. Replace the clutch cover and recheck that the actuator arm position in the correct position.



- b)** If you are unable to get the correct position using the pinion gear get to a close position, remove the snap ring on the actuator arm and realign the actuator arm on the shaft to the correct position. Reinstall the snap ring.



4. Reinstall the water pump cover, then reinstall the cable actuator arm bracket.
5. Lightly tighten the cover bolts in a star pattern, then torque the clutch cover bolts in small increments in a star pattern to OE specifications.

6. Reinstall the clutch cable to the clutch actuator arm, then bend the tab down to lock the cable in place. This may require channel-lock pliers to reattach.



7. Add oil and coolant according to the OE instructions.
8. Check the clutch lever for free play. The clutch lever should move smoothly when it is pulled toward the handlebar and return quickly when it is released.

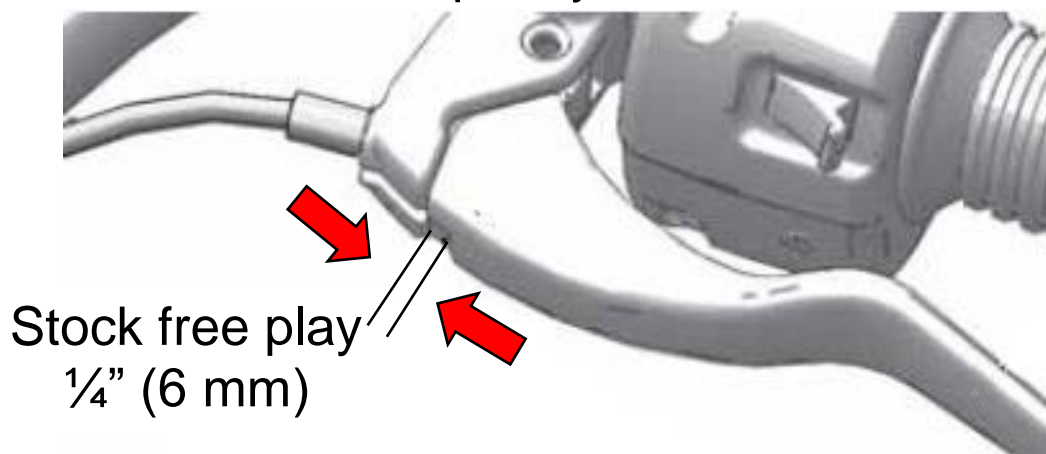

Note: Stock free play is the amount of lever movement from the perch to clutch lever engagement. Clutch lever free play should measure .20-.39\" (5-10 mm).

9. Adjust free play using the threaded cable tension adjuster by the clutch cover or by adjusting the tension with the perch adjuster.



BREAK-IN

- The clutch will break in within 100-200 miles of normal riding. Until break-in is complete, you may experience more clutch drag than normal.
- It is recommended to do an oil change after the first 1,000 miles to drain any excess clutch debris that occurred from break-in.

TROUBLESHOOTING

Clutch Drag:

- Cold Drag Only – If drag occurs only while the bike is cold, oil is the most likely cause. Be sure to warm up the bike before riding/racing. Use of new or lighter weight oil can help to minimize cold drag.
- Hot and Cold Drag –Check for any warped steel drive plates or frictions in the clutch pack, or other signs of wear caused by extreme heat.

Clutch Slip:

- If clutch slip occurs, inspect the clutch for signs of wear or heat.

MAINTENANCE

To keep your clutch performing at its best, perform regular maintenance on your bike and clutch. Clutch longevity and performance is greatly increased with oil quality and other bike factors that reduce engine heat.

- Inspect all of your clutch parts at regular maintenance intervals for signs wear or excessive heat, and replace components as necessary. Clutch wear is dependent on the riders use.
- Inspect and replace basket sleeves if they appear to be notched from friction disks.
- Keep up with regular oil changes as per the bike manufacturer's recommendations. Clutch performance and longevity depend on oil quality.
- For optimal clutch performance Rekluse recommends using fresh, clean oil that **meets JASO-MA** oil rating requirements. Rekluse offers Factory Formulated Oil™ developed specifically for Rekluse products. Rekluse Factory Formulated Oil is a perfect complement to any

OEM or aftermarket wet clutch. Visit www.rekluse.com to learn more.

- Repeat the break-in procedure anytime you replace the friction disks. Always soak friction disks in new oil for at least 5 minutes before installing.

Disk inspection examples

When inspecting the clutch pack, the following pictures can be used as a reference. **These are best viewed in color by viewing this install document at www.rekluse.com/support.**

Drive Plates – If the clutch pack is getting high amounts of heat, purple, blue, or black color can be seen on the drive plate teeth. See pictures below. Not all drive plates look the same and may look different than pictured.



Normal Heat



High Heat
(Blue)



Excessive Heat
(Black)

Friction Disks – Due to the dark color of the friction material, the friction disks will appear almost black as soon as they are put in oil. During inspection, look for glazing of the friction material. Glazing will appear shiny and feel like glass, even after oil is cleaned from the friction disk. Not all friction disks look the same and may look different than pictured.



Normal Friction



Glazed Friction

NEED ADDITIONAL HELP?

Website

www.rekluse.com/support

Frequently asked questions

www.rekluse.com/faq

Support Videos

www.rekluse.com/support/videos

Phone

(208) 426-0659

Technical Support

Contact Technical Support for questions related to product installation, tuning, and performance.

Hours:

Monday thru Friday: 8:00 a.m. - 5:00 p.m.

Mountain Time zone

Email: tech@rekluse.com

Customer Service

Contact Customer Service for additional product information, orders, and returns.

Hours:

Monday thru Friday: 8:00 a.m. - 5:00 p.m.

Mountain Time zone

Email: customerservice@rekluse.com



SETUP SHEET 198-2807012

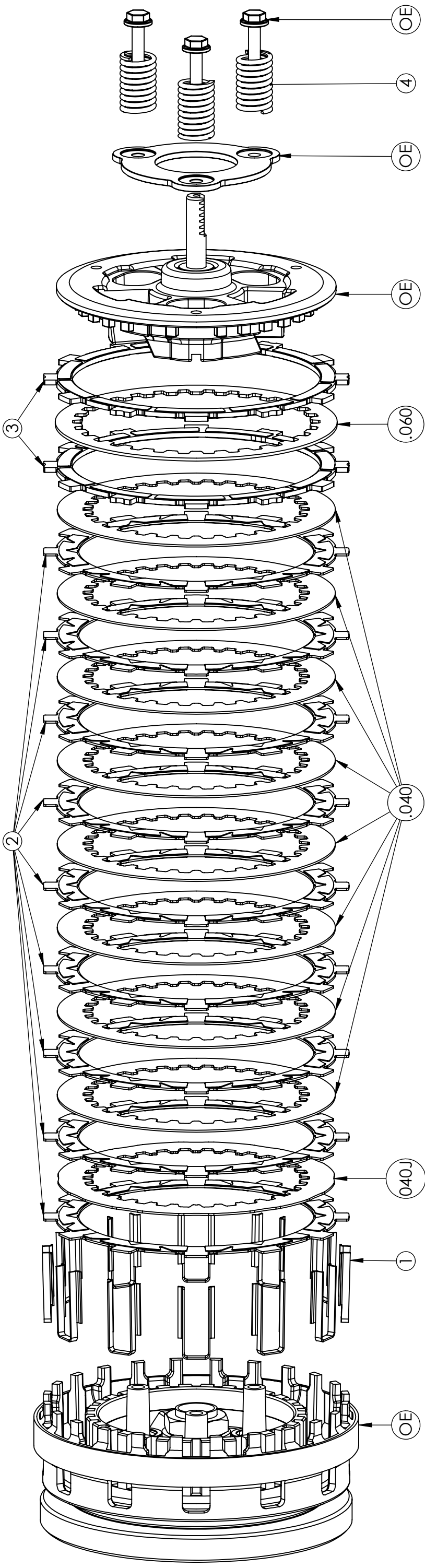

SERVICE LIMITS

COMPONENT	STANDARD	SERVICE LIMIT
TORQDRIVE FRICTION	.068-.072in 1.73-1.83mm	.065in 1.65mm
THICK FRICTION	.128-.132in 3.25-3.35mm	.125in 3.18mm

COMPONENTS

ITEM NO.	DESCRIPTION	QTY.
1	BASKET SLEEVE	12
2	TORQDRIVE FRICTION 0.070" (1.78mm)	9
3	THICK FRICTION	2
4	PRESSURE PLATE SPRING	3
040J	JUDDER DRIVE PLATE 0.040" (1.0mm)	1
.040	DRIVE PLATE 0.040" (1.0mm)	8
.060	DRIVE PLATE 0.060" (1.5mm)	1

CLUTCH PACK THICKNESS

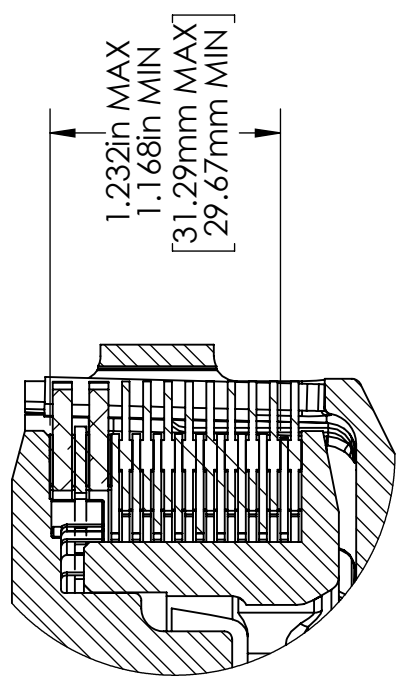

DETAIL A
SCALE 1 : 1

