



INSTALLATION & USER'S GUIDE

TorqDrive Clutch
YXZ 1000

Doc ID: 191-2870A
Revision: 040919

Table of Contents

OVERVIEW3
INSTALLATION TIPS3
TOOLS.....4
INCLUDED PARTS5
DISASSEMBLE CLUTCH.....6
CLUTCH INSTALLATION8
INSTALL THE PRESSURE PLATE.....11
BREAK-IN.....15
SHIFTING AND OPERATION15
MAINTENANCE.....15
DISK EXAMPLES FOR INSPECTION17
NEED ADDITIONAL HELP?.....18

OVERVIEW

This kit replaces many of the OE (Original Equipment) clutch parts. The following is a summary of what is replaced:





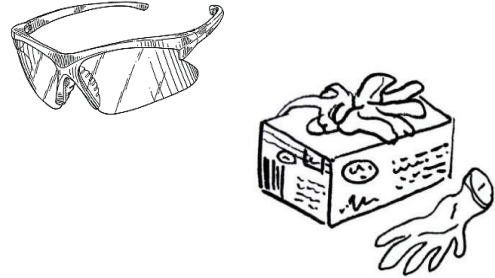

- This kit will replace all the OE frictions and drive plates with a Rekluse thin friction clutch pack.
- The OE pressure plate is replaced with a Rekluse pressure plate.
- The OE pressure plate springs are replaced with high quality Rekluse springs.

INSTALLATION TIPS

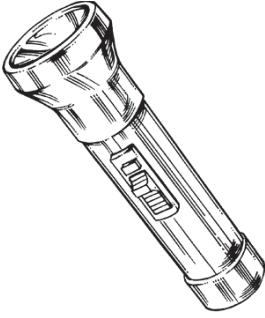
- Read the separate included Safety Information document before operating the vehicle with the product installed.
- Read this entire document before performing any steps.
- If you install this product for a customer or another person, instruct them to read the **Safety Information** document and the **Installation and User Guide** before operating the bike with the product.
- Protect eyes and skin – wear safety glasses and work gloves.
- Use the torque values listed in the instructions. Otherwise, use the torque specifications found in your OE service manual.
- For optimal clutch performance Rekluse recommends using fresh, clean oil that **meets JASO-MA** oil rating requirements. Rekluse offers Factory Formulated Oil™ developed specifically for Rekluse products. Rekluse Factory Formulated Oil is a perfect complement to any OEM or aftermarket wet clutch. Visit www.rekluse.com to learn more.



TOOLS

			
<p>Flashlight</p>	<p>Magnet Stick (X2)</p>	<p>Metric Wrench Set</p>	<p>Torque Wrench</p>
	 <p>5 mm</p>		
<p>Pick</p>	<p>5 mm Hex key</p>	<p>Metric Socket Set</p>	

INCLUDED PARTS

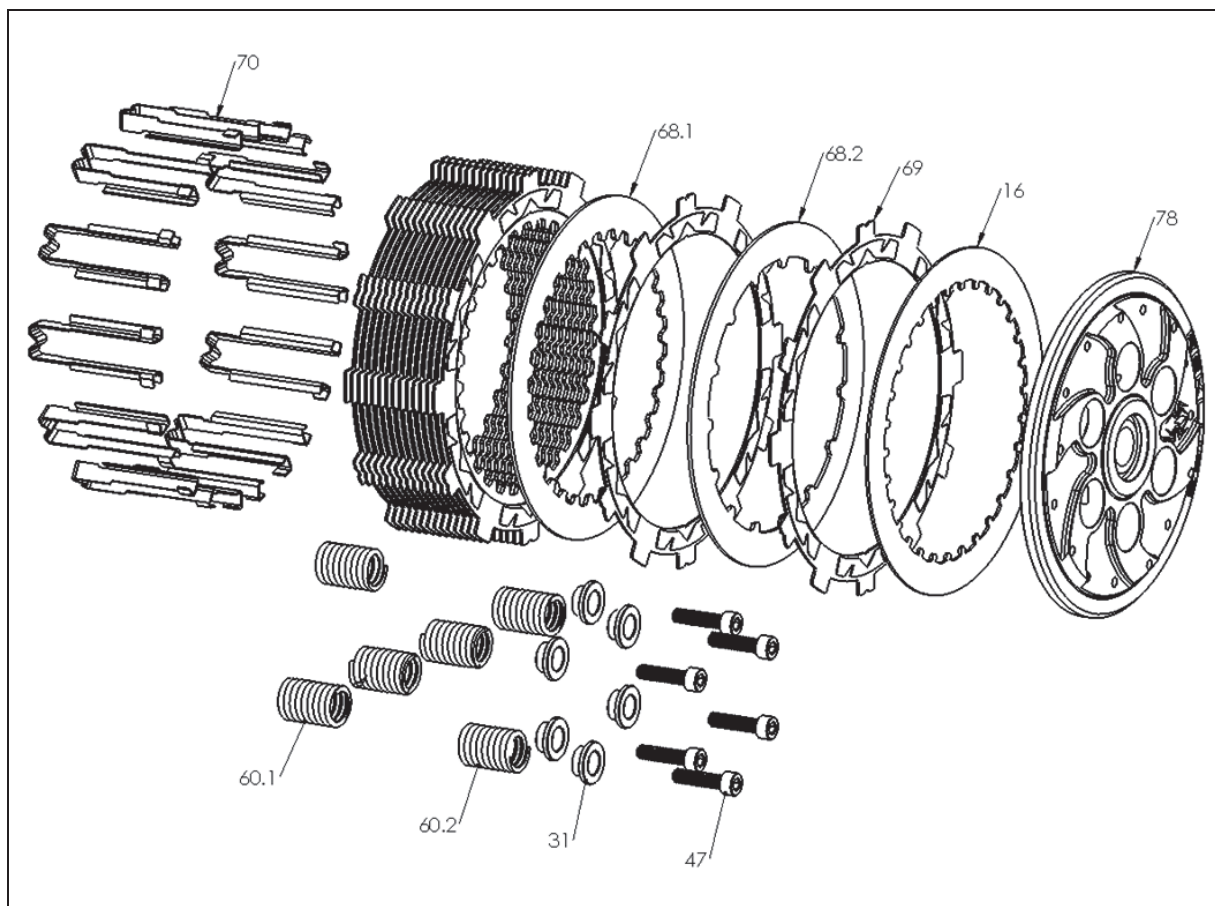

Item	Description	Qty.
16	Lining Plate	1
31	Spring Sleeve	6
47	Fastener	6
60.1 / 60.2	Pressure Plate Springs Blue and Red	6
68.1	Drive Plate	14
68.2	Drive Plate – Skip tooth	1
69	TorqDrive Friction Disk	16
70	Basket Sleeves	12
78	Pressure Plate Assembly	1
Not Shown	Pressure Plate Springs Gold	6
Not Shown	Clutch cover gasket	1

Visit www.rekluse.com/support for a full parts fiche illustration and part numbers.

DISASSEMBLE CLUTCH

1. Soak the included friction disks in engine oil for at least 5 minutes. Make sure the friction disks are coated on both sides.

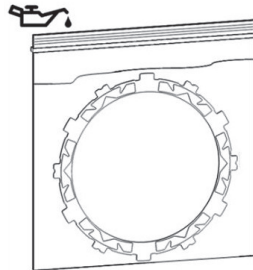

2. Remove the driver seat, passenger seat and center console body panels to access to the clutch cover.
3. Remove the clutch cover bolts and clutch cover. Refer to vehicle service manual for instructions.
 - It is not necessary to drain the oil however it is recommended to change the oil after clutch break-in.

NOTICE

The bolts along the bottom of the clutch cover also have copper crush washers. Be sure to reinstall the crush washers with the bolts in the proper locations.

4. Remove the following OE parts. See picture for reference.
 - Lower clutch pack with damper springs
 - Wire circlip
 - Upper clutch pack
 - Pressure plate
 - Spring seat
 - Spring
 - Spring retainer
 - Bolts

NOTICE

*To remove the lower clutch pack, you will need to remove the wire circlip from the inner hub. To remove the wire circlip, use needle nose pliers and/or picks. The wire circlip **WILL NOT** be re-used.*

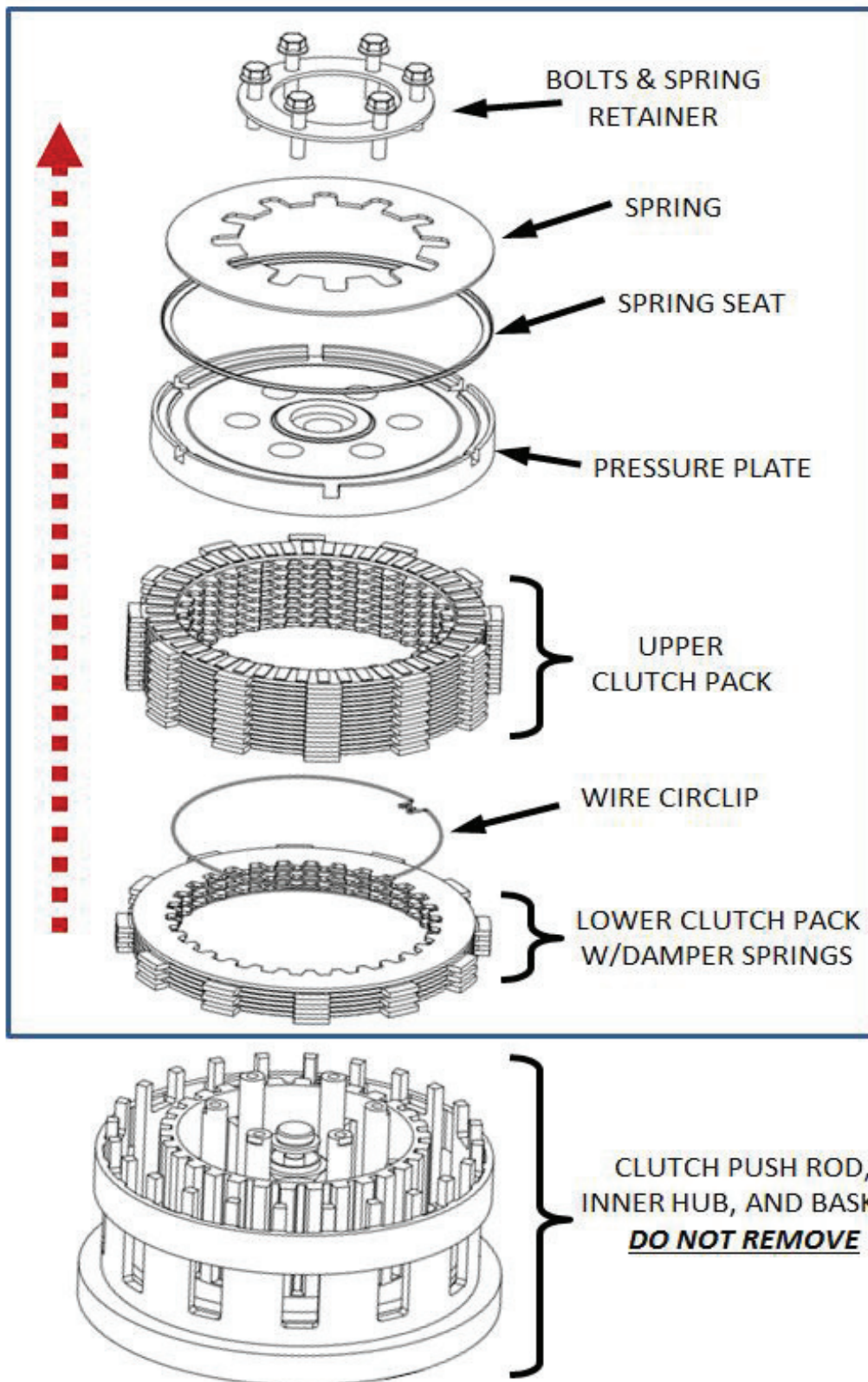

5. Ensure all parts of the lower clutch pack are removed. The push rod, inner hub, and basket do not need to be removed.

6. Use magnets to remove damper spring and damper spring seat from the bottom of the lower clutch pack.

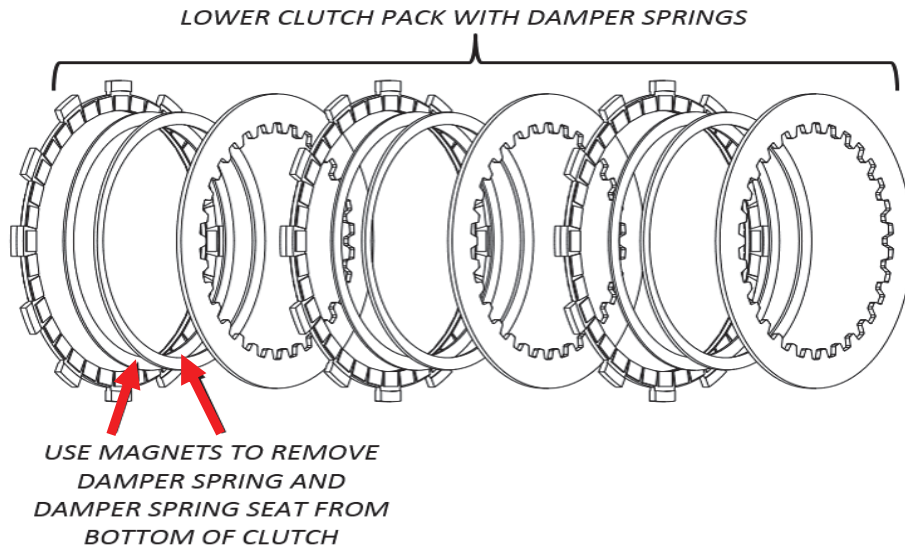

CLUTCH INSTALLATION

Clutch Pack Cutaway Overview

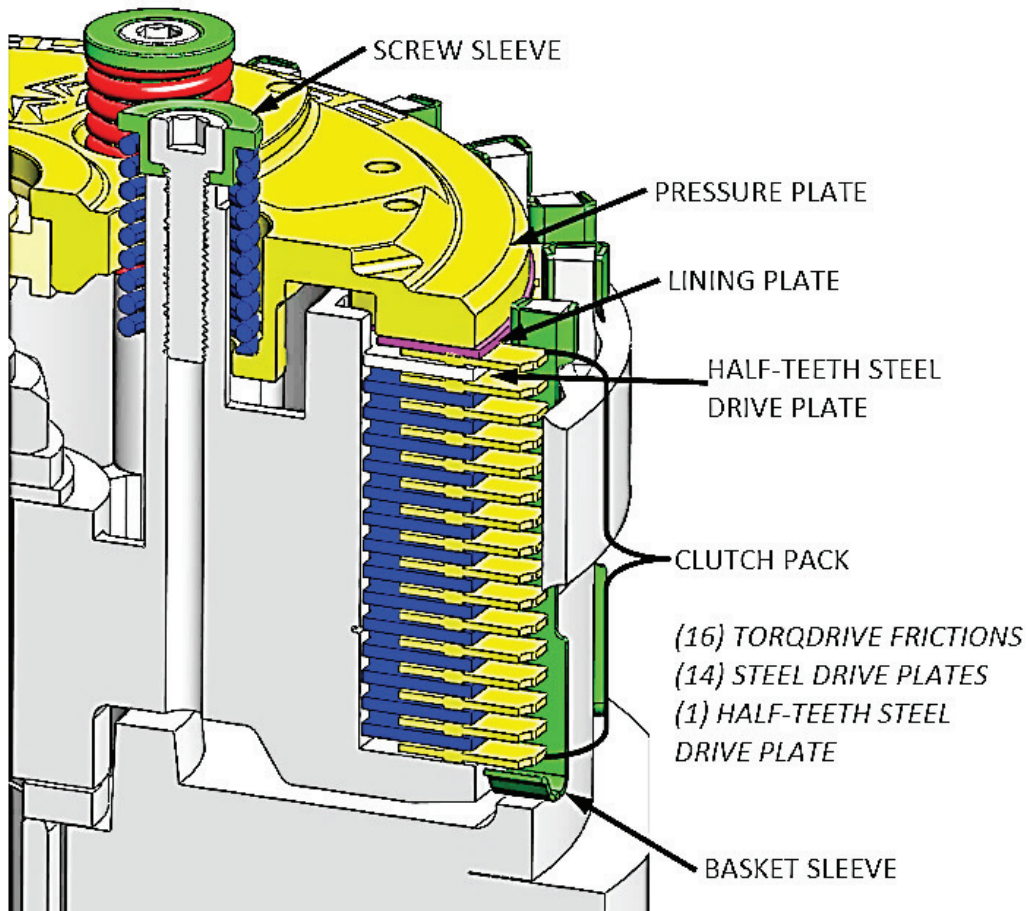

1. Inspect the clutch basket for damper/cushion play or notching. Do not install sleeves or use product with a notched basket. Notched basket tang faces or worn dampers can cause the sleeves to break.

⚠ WARNING

Failure to inspect the basket and replace if necessary could result in death, serious injury, and/or property damage.

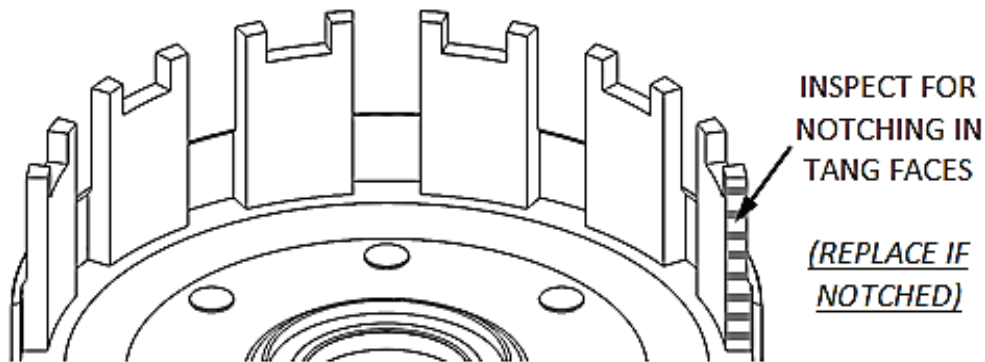

2. Install all of the Rekluse basket sleeves into the basket slots. Make sure the bottom of the sleeve is facing down, and the long sleeve tabs sit against the inside of the basket. See pictures for reference.

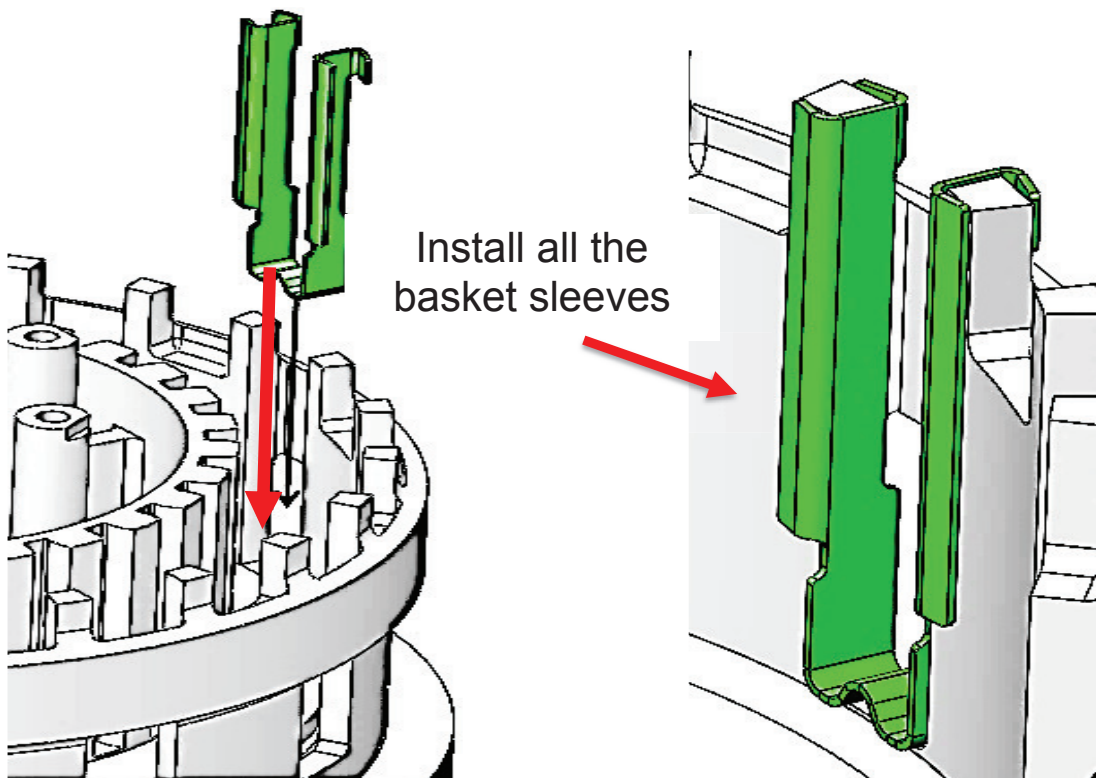

3. Ensure damper spring, damper spring seat, and bottom narrow friction were removed. *The clutch will not install properly if these parts are still in place.*
4. Install a friction disk into the clutch basket, then install a steel drive plate. *Some friction disks are marked with a small colored dot. This mark is used for processing and can be ignored.*

NOTICE

Some OE basket have “half slots” at the top of the basket tangs. Rekluse products require the entire clutch pack be installed into the MAIN (deeper) basket slots. (These slots are lined with the basket sleeves.) See the following picture for reference.

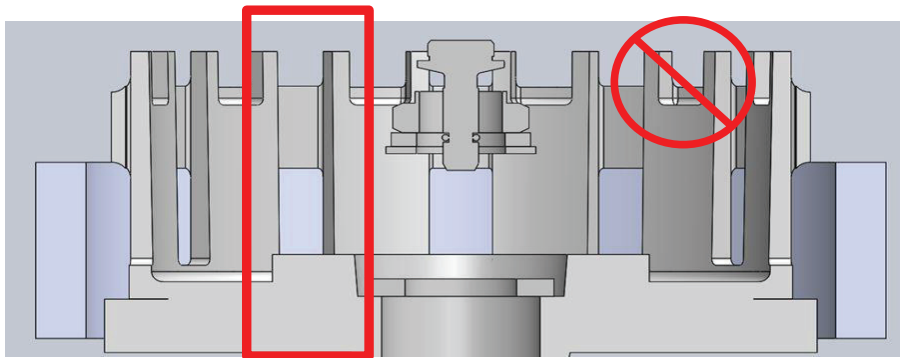

5. Continue to alternate **14** friction disks and **13** steel drive plates into the clutch. *You will end with a friction disk on top and have 1 friction disk left over.*

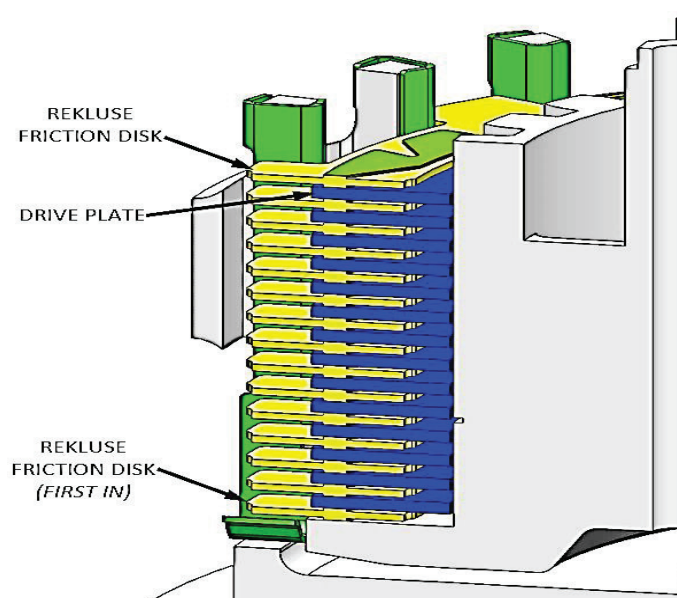

INSTALL THE PRESSURE PLATE

NOTICE

The pressure plate requires two different plates be correctly aligned in order for the clutch to function properly.

1. Install the skip tooth steel drive plate onto the clutch pack by aligning 2 of the plate's teeth in the **CENTER** of any 2 bolt posts on the inner hub.



2. Install the last Rekluse friction disk on top of the skip tooth drive plate. *Be sure to line up the tabs on the friction disk with the rest of the pack in the main basket slots.*

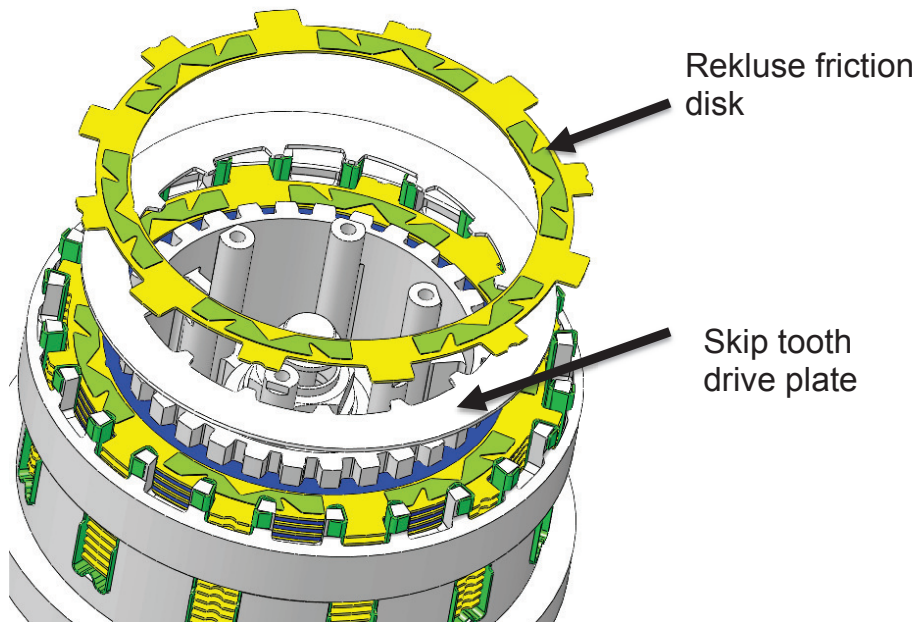

3. Turn the pressure plate over and place a thin layer of oil between the lining plate and the pressure plate. *This will help hold the lining plate in place while installing the pressure plate over the clutch pack.*

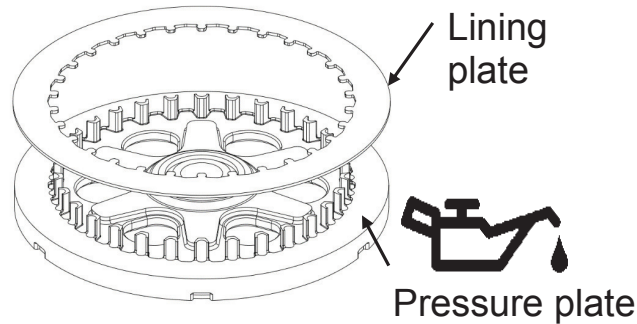

4. Align the teeth of the lining plate with the taller slots in the pressure plate, then drop the lining plate into the slots. *The lining plate will sit flush with the pressure plate.*



5. Turn the pressure plate assembly over and locate the small hole directly above the part number.

NOTICE

This will be a reference point for lining up the pressure plate. You can mark this point with a marker as well for ease of installation.



- Align the small hole on the pressure plate **BETWEEN** the two centered teeth of the skip tooth drive plate. *The spring cups in the pressure plate will align with the posts in the hub.*

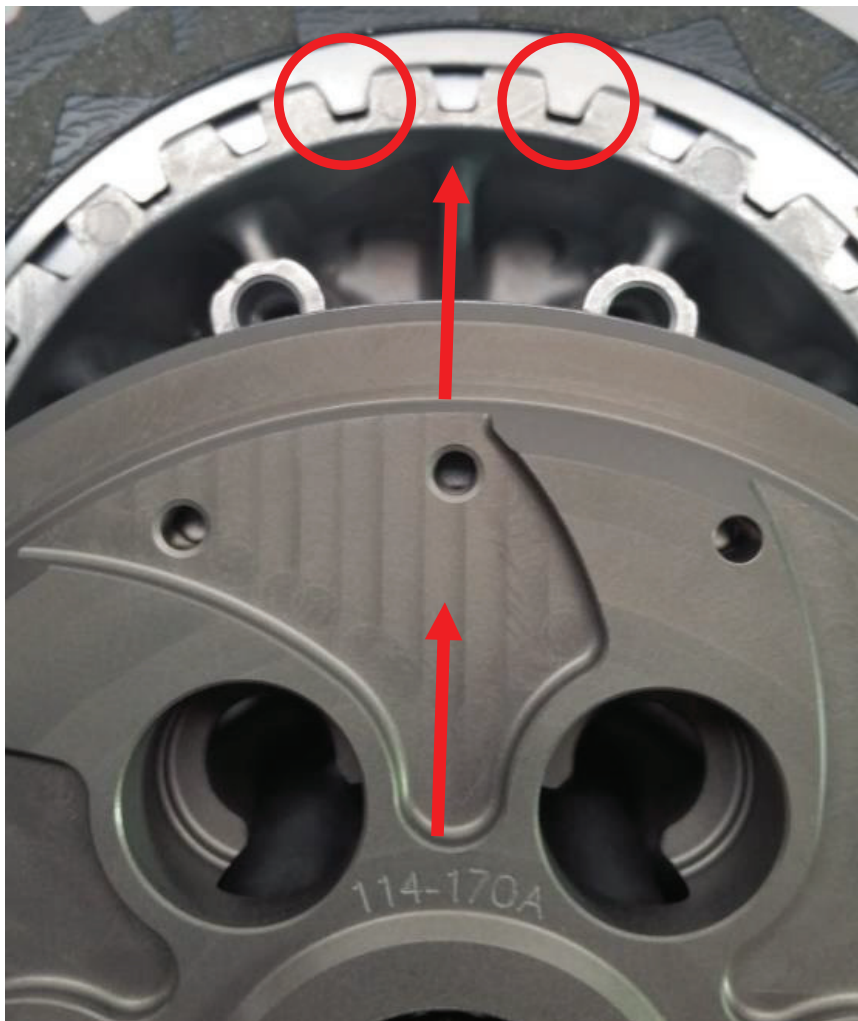

Center the skip tooth drive plate between posts

Align small hole above the part number between teeth

Pressure plate holes will align with posts in hub

- Slide the pressure plate into place.
- Using every other spring cup, install 3 of the pressure plate springs, spring sleeves, and pressure plate bolts. Tighten until snug. *You will install the other 3 in a later step.*

NOTICE

Use the following tuning information to select the appropriate springs for your model.

- **YXZ1000R SS and YXZ1000RSS SE models**

- The only spring option for your model is six gold springs. Install 3 gold springs now, and the other 3 gold in the final step.

- **YXZ1000R and YXZ1000R SE models**

- The recommended pressure plate spring setting is 3 red and 3 blue. Install one color for the first 3, then the other color for the final step.

- For a more aggressive clutch, install 6 blue springs total.

- For a more forgiving clutch, install 6 red springs total.

9. Check that the pressure plate is aligned correctly by trying to move the top friction disk.

a. If the friction does not move, the plate is installed correctly.

b. If the plate moves or wiggles, remove the pressure plate and realign the plates beginning with the step to install the skip tooth plate.

10. Once aligned correctly, install all the springs, spring sleeves and bolts, then torque bolts to 8 N-m as specified in the Yamaha service manual.

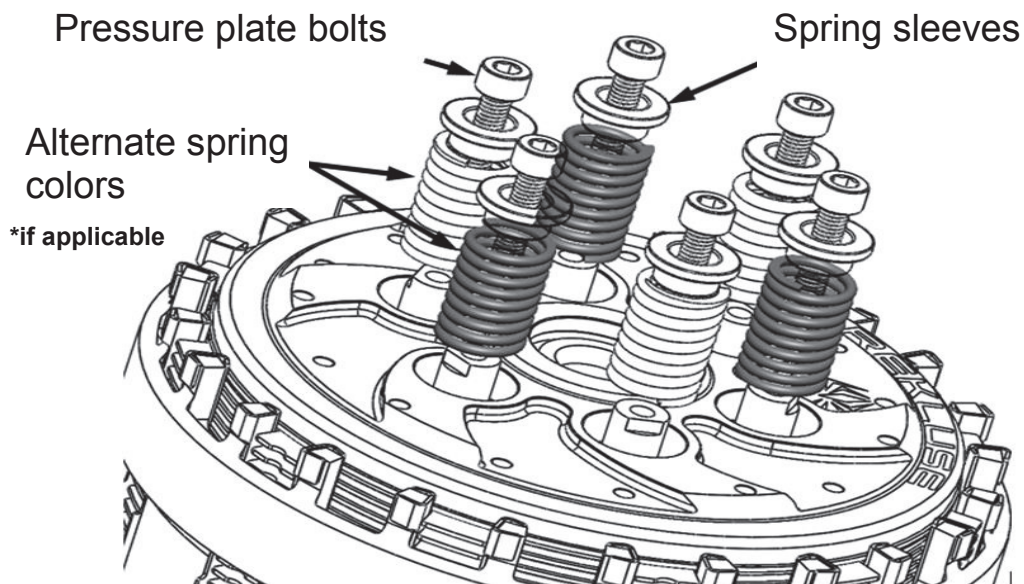

11. Install the provided clutch cover gasket onto the clutch cover.
12. Reinstall the clutch cover, copper crush washers, and cover bolts. *Be sure to reinstall the crush washers with the bolts in the proper locations.*
13. Lightly tighten the clutch cover bolts in a star pattern. Torque the bolts in small increments before tightening the bolts to 10 N-m as per specification found in the Yamaha service manual.
14. Reinstall the center console body panels, the driver seat, and the passenger seat.

BREAK-IN

Break-in will occur over the first 1-2 hours of use, depending on the rider. During break-in more clutch drag may occur than normal.

SHIFTING AND OPERATION

- Always use proper gear selection for the speed and situation whether accelerating or slowing down.
- When accelerating from a stop it is best to start in 1st gear in order to prevent excessive slipping of the clutch. Starting in too tall a gear repeatedly will prematurely wear out the clutch resulting in failure.
- Shifting without using the clutch pedal is possible with good timing similar to clutch-less shifting a manual clutch equipped vehicle.

MAINTENANCE

- Keep up with regular oil changes as per the vehicle manufacturer's recommendations. Clutch function and longevity depends on oil quality.

- For optimal clutch performance Rekluse recommends using fresh, clean oil that **meets JASO-MA** oil rating requirements.
- Inspect all of your clutch parts at regular engine service intervals for signs of wear or excessive heat, and replace components as necessary.
- Excessive heat or clutch slip can cause premature clutch failure. Once extreme temperatures are reached, irreversible damage will occur. Inspect your clutch plates. If the friction plates look burnt or glazed, or the drive plates are warped, it is best to replace the entire clutch pack.

DISK EXAMPLES FOR INSPECTION

When inspecting the clutch pack, the following pictures can be used as a reference. **These are best viewed in color by viewing this install document on www.rekluse.com/support.**

Drive Plates – If the clutch pack is getting high amounts of heat, purple, blue, or black color can be seen on the drive plate teeth. See pictures below. Not all drive plates look the same and may look different than pictured.



Normal Heat

High Heat
(Blue)

Excessive Heat
(Black)

Friction Disks – Due to the dark color of the friction material, the friction disks will appear almost black as soon as they are put in oil. During inspection, look for glazing of the friction material. Glazing will appear shiny and feel like glass, even after oil is cleaned from the friction disk. Not all friction disks look the same and may look different than pictured.



Normal Friction



Glazed Friction

NEED ADDITIONAL HELP?

Website

www.rekluse.com/support

Frequently Asked Questions

www.rekluse.com/faq

Support Videos

www.rekluse.com/support/videos

Phone

(208) 426-0659

Technical Support

Contact Technical Support for questions related to product installation, tuning, and performance.

Hours:

Monday thru Friday: 8:00 a.m. - 5:00 p.m.

Mountain Time zone

Email: tech@rekluse.com

Customer Service

Contact Customer Service for additional product information, orders, and returns.

Hours:

Monday thru Friday: 8:00 a.m. - 5:00 p.m.

Mountain Time zone

Email: customerservice@rekluse.com

