



INSTALLATION & USER'S GUIDE

TorqDrive Manual Clutch
for KTM 1190 RC8 and RC8R

Doc ID: 191-2886A

Revision: 040919

TABLE OF CONTENTS

OVERVIEW	2
INSTALLATION TIPS	3
TOOLS NEEDED.....	3
INCLUDED PARTS	4
DISASSEMBLE THE CLUTCH	5
CLUTCH PACK INSTALLATION.....	7
Notes for clutch pack installation:.....	7
Clutch pack.....	8
FINISH INSTALLATION	11
BREAK-IN.....	11
MAINTENANCE.....	11
Clutch wear.....	11
Clutch parts	11
Basket.....	12
Disk inspection examples.....	12
TROUBLESHOOTING.....	13
Clutch Drag.....	13
Clutch Slip	14
NEED ADDITIONAL HELP?.....	15

OVERVIEW

This kit replaces the OE (Original Equipment) or “stock” clutch pack with a Rekluse-designed high quality clutch pack designed specifically for your bike model. The following is a summary of what is replaced:

- All OE steel drive plates will be replaced with Rekluse drive plates
- All OE friction disks will be replaced with Rekluse TorqDrive® disks

INSTALLATION TIPS

- Read the safety information sheet included with your kit.
- If you install this product for a customer or another person, instruct them to read the **Safety Information** document and the **Installation and User Guide** before operating the bike with the product.
- Protect eyes and skin – wear safety glasses and thin disposable work gloves. Work in a well ventilated area.
- Read this entire document before performing any steps.
- For optimal clutch performance Rekluse recommends using fresh, clean oil that **meets JASO-MA** oil rating requirements. Rekluse offers Factory Formulated Oil™ developed specifically for Rekluse products. Rekluse Factory Formulated Oil is a perfect complement to any OEM or aftermarket wet clutch. Visit www.rekluse.com to learn more.
- Use the torque values listed in the instructions. Otherwise, use the torque specifications found in your OE service manual.

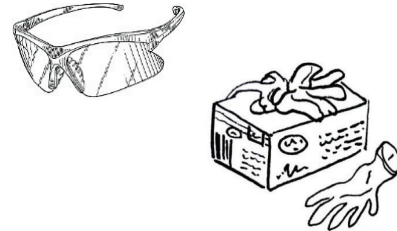

TOOLS NEEDED

- 4 mm Hex key
- Metric socket set
- Fluid catch container
- Clutch fluid (mineral oil)
- Torque wrench
- Metric end wrench set

INCLUDED PARTS

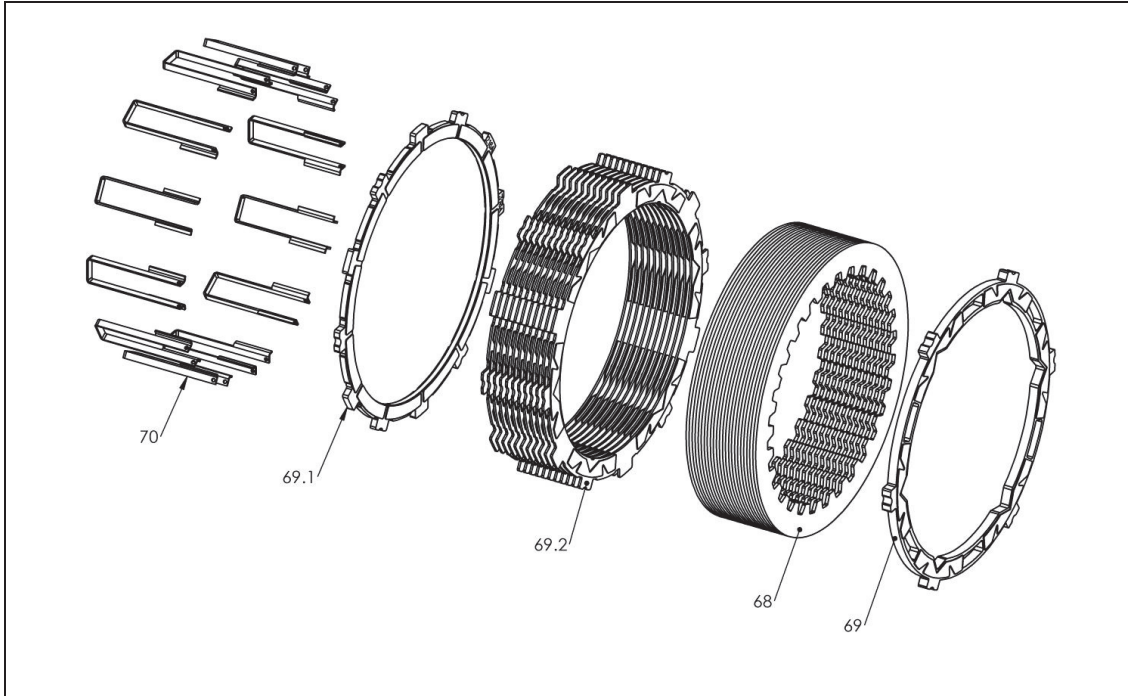

Item	Description	Qty.
70	Basket sleeves	12
69.1	Thick friction disk - .150" (3.81 mm)	1
69.2	TorqDrive® friction disks	11
68	Steel drive plates	12
69	Thick friction disk – .218" (5.54 mm)	1

Visit www.rekluse.com/support for a full parts fiche illustration and part numbers.

DISASSEMBLE THE CLUTCH

1. Soak all the friction disks in engine oil for 5 minutes. Make sure the friction disks are coated on both sides.

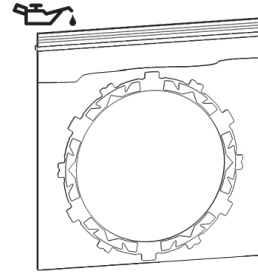

2. To ease the process of installation, remove any fairings or covers impeding to access the oil drain plugs, clutch cover, and clutch slave cylinder.



3. Stand the bike vertically on its center stand and drain the oil.

NOTE: To avoid draining the oil, you can use the bike's kickstand and block the rear tire up a few inches to increase the bike's lean angle. A small amount of oil may still spill out of the clutch cover using this method.

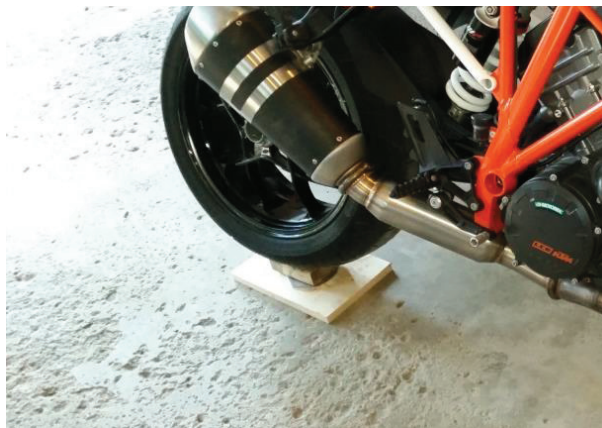

4. Remove the clutch cover bolts and clutch cover. Set the cover and bolts aside. They will be reused.

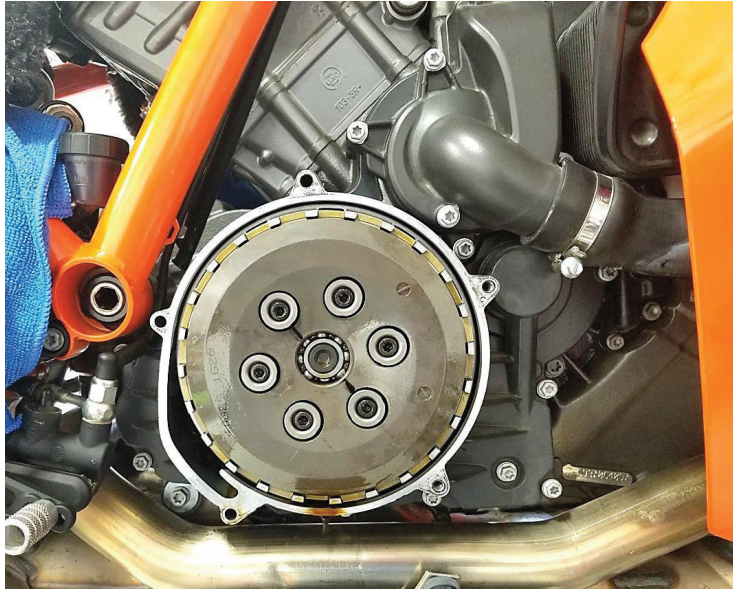

5. Remove the following OE clutch parts.

- Pressure plate bolts
- Pressure plate springs
- OE clutch pack
- Judder (boss) spring
- Judder seat

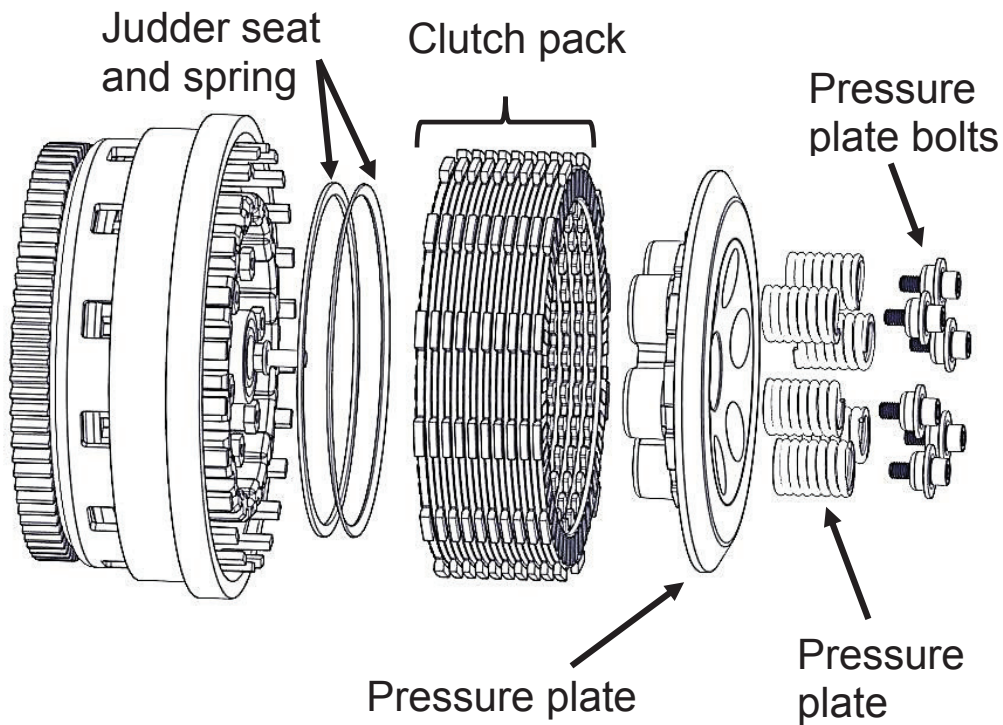

CLUTCH PACK INSTALLATION

Notes for clutch pack installation:

- *Some friction disks are marked with a small colored dot. This mark is used for processing and can be ignored.*
- *When installing the clutch pack, note the position of basket slots. Some OE basket have “half slots” at the top of the basket tangs. Do not use the “half slots.” Rekluse products require the entire clutch pack be installed into the MAIN (deeper) basket slots.*

Use only the deeper basket slots for installation

Do not use the “half-slots”

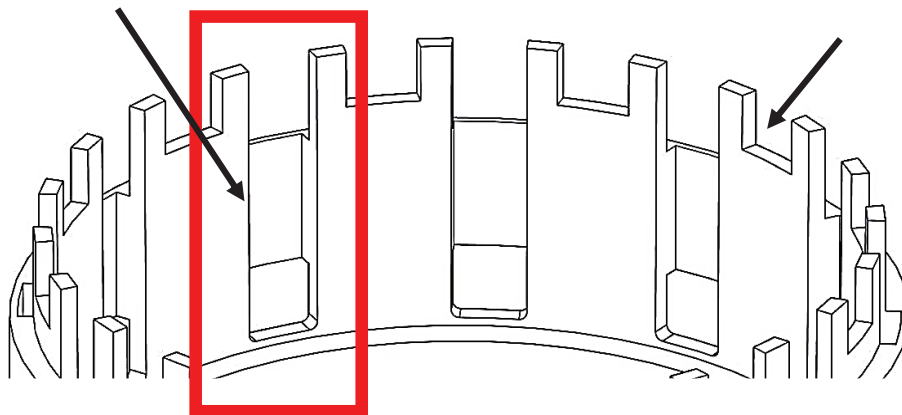

- *When assembling the clutch pack, it is important to line up the alignment notches on the friction disk tabs. Correct alignment is critical for optimal performance.*

Align notches of friction disks

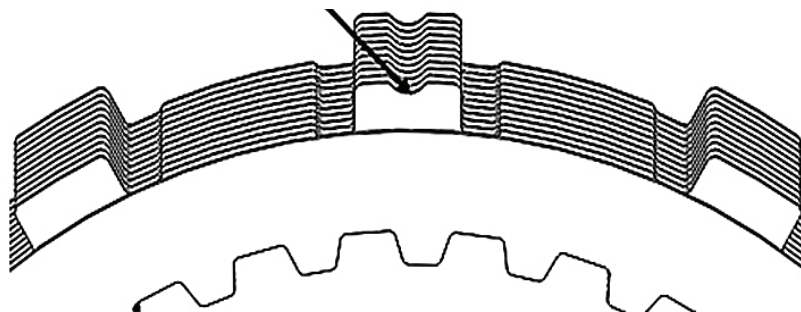

Clutch pack

1. Inspect the clutch basket for damper and/or spring rotational play. Dampers/springs should not be loose. Inspect the clutch basket for notching.
 - Do not install basket sleeves or use product with a notched basket. Notched basket tang faces can cause the sleeves to break. Do not use baskets that have been filed, machined, or modified at the tangs. Replace basket if necessary.

⚠ WARNING

Failure to inspect the basket and replace if necessary could result in death, serious injury, and/or property damage.

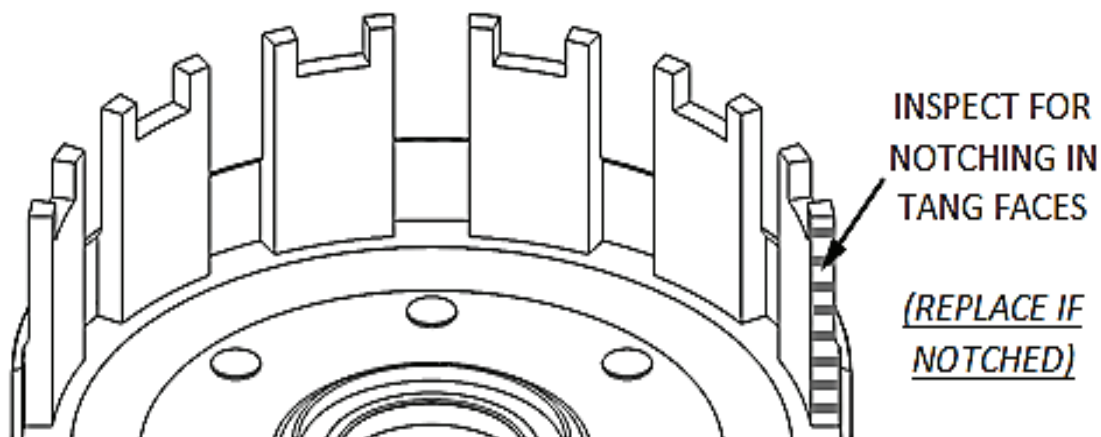

2. Install **ALL** the Rekluse basket sleeves into the basket slots. Make sure the sleeve tabs sit against the inside of the basket, then push the sleeves down until they contact the bottom of the tang slot. See pictures for reference.

NOTE: When seated in the basket slots, the sleeves will sit slightly below flush with the top of the basket tangs. This is normal.

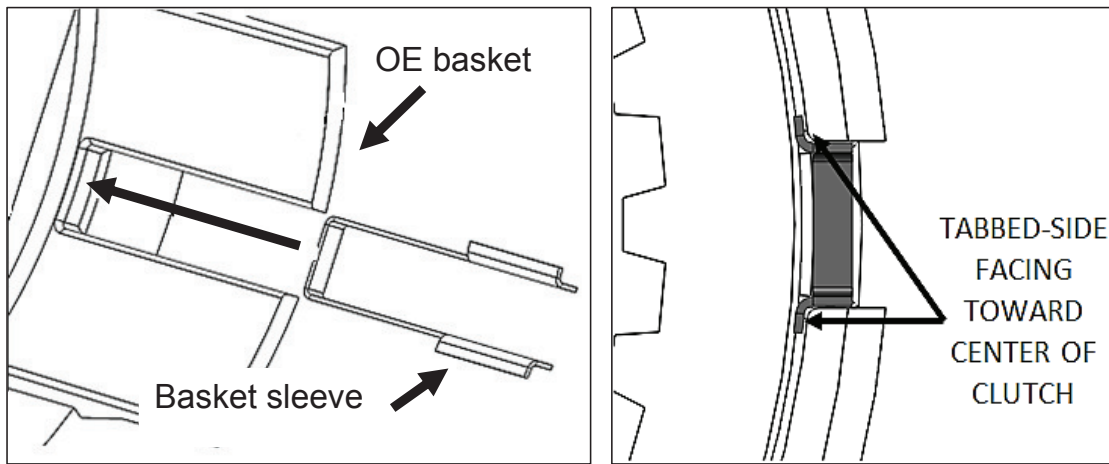

3. Reinstall the OE judder spring seat, then reinstall the OE judder spring with the cupped side facing up.

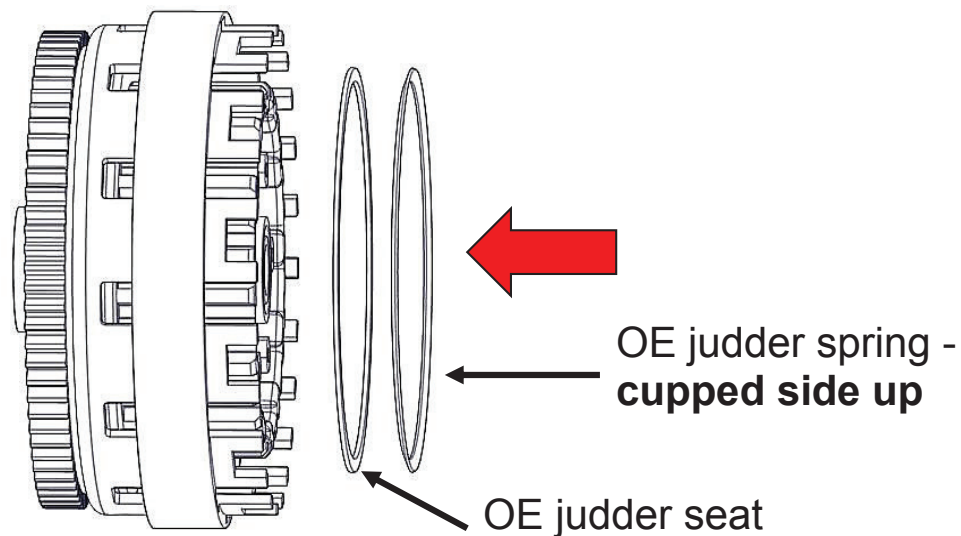

4. Install the Rekluse thick friction disk - .150" (3.81 mm) into the clutch, and then install a steel drive plate.

5. On top of the steel drive plate, alternate 11 thin friction disks with 11 steel drive plates, ending with a steel drive plate.

6. Install the thickest - .218" (5.54 mm) friction disk last.

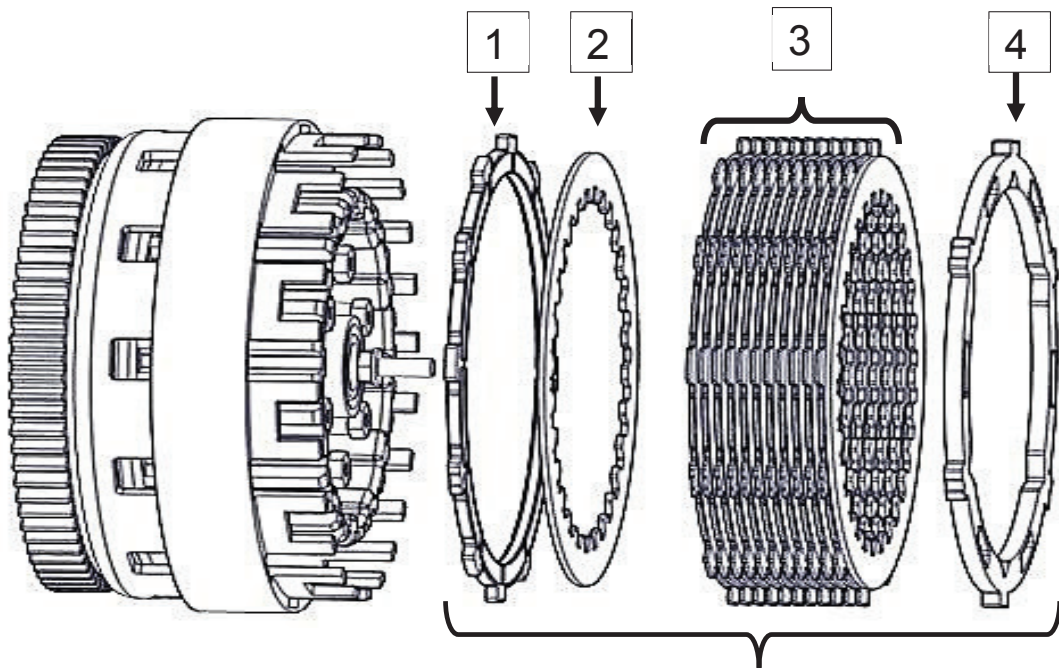

Total clutch pack:
13 frictions disks, 12 steel drive plates

1	Thick friction disk - .150" (3.81 mm)
2	Steel drive plate
3	Alternate 11 thin friction disks with 11 steel drive plates
4	Thick - .218" (5.54 mm) friction disk

Clutch cross-section

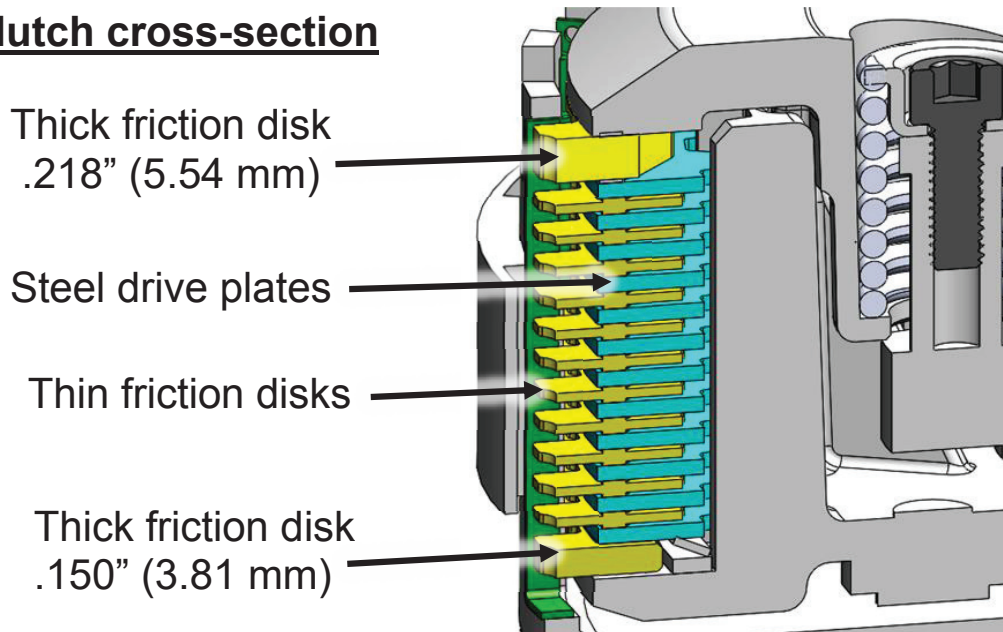

FINISH INSTALLATION

1. Reinstall the OE pressure plate.
2. Reinstall the OE pressure plate springs, then reinstall the OE pressure plate bolts.
3. Using a torque wrench, tighten the pressure plate bolts to **9 ft-lb (12 N-m)**.
4. Reinstall the clutch cover, then lightly tighten the clutch cover bolts in a star pattern. Tighten bolts in small increments before torquing the cover bolts to **7.5 ft-lb (10 N-m)**.

BREAK-IN

Break-in will occur over the first 1-2 hours of use, depending on the rider. During break-in more clutch drag may occur than normal.

MAINTENANCE

Clutch wear

Rekluse clutches are built using high quality materials but do wear based on the rider's use, type of terrain, and natural wear and tear. To keep your clutch performing at its best, perform regular maintenance on your bike and clutch based on your riding style.

Clutch parts

- Inspect all of your clutch parts at regular intervals for signs of wear or excessive heat, and replace components as necessary. Rekluse recommends inspecting after the first 10 hours of use, then every 20 hours after that.
- Measuring the clutch pack can help determine if the components need replacing.

- Replace friction disks or drive plates if they are glazed and/or burnt.
- Keep up with regular oil changes as per the bike manufacturer's recommendations. Clutch performance and longevity depend on oil quality.
- For optimal clutch performance Rekluse recommends using fresh, clean oil that **meets JASO-MA** oil rating requirements.

Basket

- Inspect the basket dampers and/or springs by checking the play between the ring gear and the basket. Replace the dampers/springs if you feel any play in the assembly.
- Inspect and replace basket sleeves if they appear to be notched from friction disks. Rekluse recommends replacing them every 25 hours for abusive riding/racing, every 50 hours for moderate riding, or every time friction disks are replaced.

Disk inspection examples

When inspecting the clutch pack, the following pictures can be used as a reference. **These are best viewed in color by viewing this install document from www.rekluse.com/support.**

Drive Plates

If the clutch pack is getting high amounts of heat, purple, blue, or black color can be seen on the drive plate teeth. See pictures below. Not all drive plates look the same and may look different than pictured.



Normal Heat

High Heat
(Blue)

Excessive Heat
(Black)

Friction Disks

Due to the dark color of the friction material, the friction disks will appear almost black as soon as they are put in oil. During inspection, look for glazing of the friction material. Glazing will appear shiny and feel like glass, even after oil is cleaned from the friction disk. Not all friction disks look the same and may look different than pictured.



Normal
Friction



Glazed
Friction

TROUBLESHOOTING

Clutch Drag:

- Cold Drag Only – If drag occurs only while the bike is cold, oil is the most likely cause. Be sure to warm up the bike before riding/racing. Use of new or lighter weight oil can help to minimize cold drag.

- Hot and Cold Drag –Check for any warped steel drive plates or frictions in the clutch pack, or other signs of wear caused by extreme heat.

Clutch Slip:

- If clutch slip occurs, inspect the clutch for signs of wear or heat.
- Check clutch lever free play.

NEED ADDITIONAL HELP?

Website

www.rekluse.com/support

Frequently Asked Questions

www.rekluse.com/faq

Support Videos

www.rekluse.com/support/videos

Phone

(208) 426-0659

Technical Support

Contact Technical Support for questions related to product installation, tuning, and performance.

Technical Support hours:

Monday thru Friday: 8:00 a.m. - 5:00 p.m.

Mountain Time zone

Email: tech@rekluse.com

Customer Service

Contact Customer Service for additional product information, orders, and returns.

Customer Service hours:

Monday thru Friday: 8:00 a.m. - 5:00 p.m.

Mountain Time zone

Email: customerservice@rekluse.com

