

KTM LC8 models

 Doc ID: 195-233A  
 Doc Rev: 030218

## OVERVIEW

Rebuilding the Rekluse Slave Cylinder Assembly involves replacing the O-ring seals, crush washers for the banjo bolt, and the snap ring that retains the piston in the cylinder housing.

## INCLUDED PARTS

Your kit also includes *extra* O-ring seals in case any are cut or damaged during assembly or installation:

2	Small replacement O-ring seals for the adjuster screw (may only use one, with older version)
3 or 4	Medium replacement O-ring seals for the piston
1	Large replacement O-ring seal for the cylinder housing (to seal against the engine case)
1	Snap ring to retain the piston in the cylinder housing
1	Silicone grease packet for lubricating the O-ring seals before installing them

## TOOLS NEEDED

- Internal snap-ring pliers
- 4 mm hex key
- 13 mm end wrench
- Dental pick tools
- Rubber gloves and safety glasses
- Clutch fluid, compatible with your bike



## CLUTCH FLUID TYPE NOTE:

Every O-ring seal in the clutch control system is compatible with **only one** clutch fluid type and **cannot** be used interchangeably. Read the information located on your bike's clutch fluid reservoir cap to determine which fluid system was installed by KTM. Then, check the label on your Rebuild Kit to ensure its compatibility with your bike's fluid type.

*Failure to install the correct mineral-oil-compatible O-ring seals will result in poor slave cylinder performance and may have the potential to cause fluid leaks.*

Rekluse's O-ring seals that go on the piston and adjuster screw are color-coded for ease of identification:

**BROWN** = mineral oil & engine oil compatible

**BLACK** = DOT brake fluid compatible

## SLAVE CYLINDER VERSION NOTE:

Rekluse updated the design of the LC8 slave cylinder in June 2016 to eliminate the jam nut and employ a double-O-ring adjuster screw. The parts contained in this Slave Cylinder Rebuild Kit are compatible with both the older and newer models of the slave cylinder assembly.

Use the diagrams below to determine which model that you have. The parts displayed as fully dark in color are included in this rebuild kit.

## OLDER MODEL

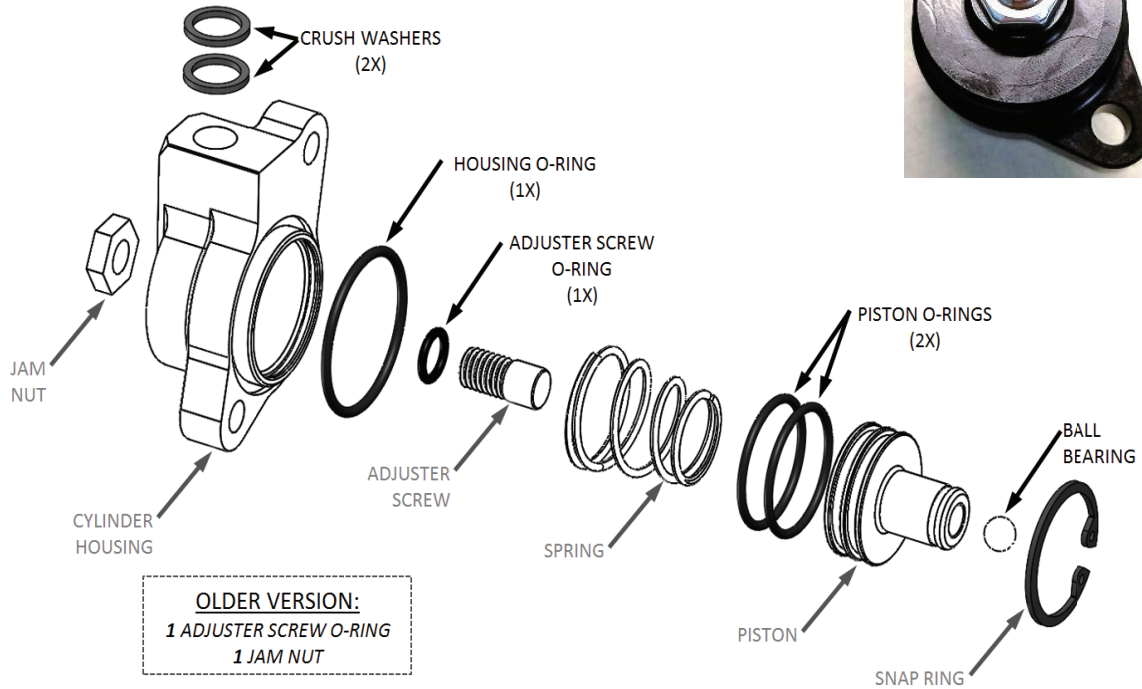

## NEWER MODEL

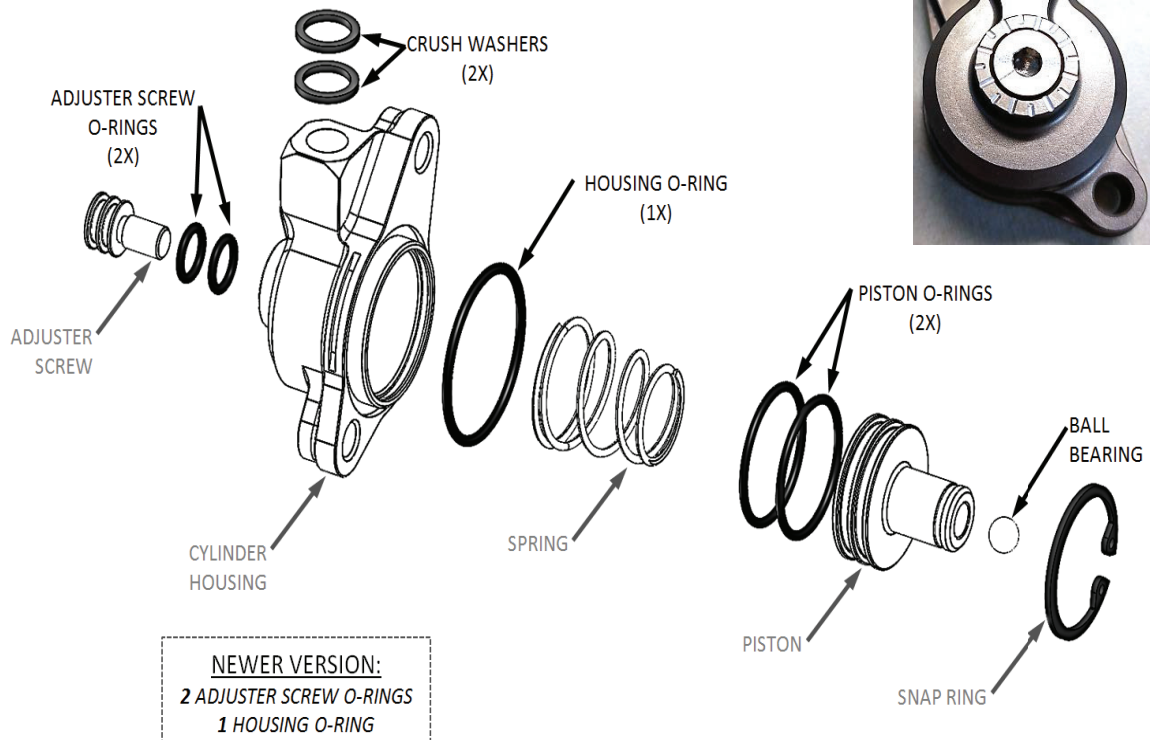

# EXPLODED & CUTAWAY VIEWS - (WITH FLUID COMPATIBILITY)

## OLDER MODEL

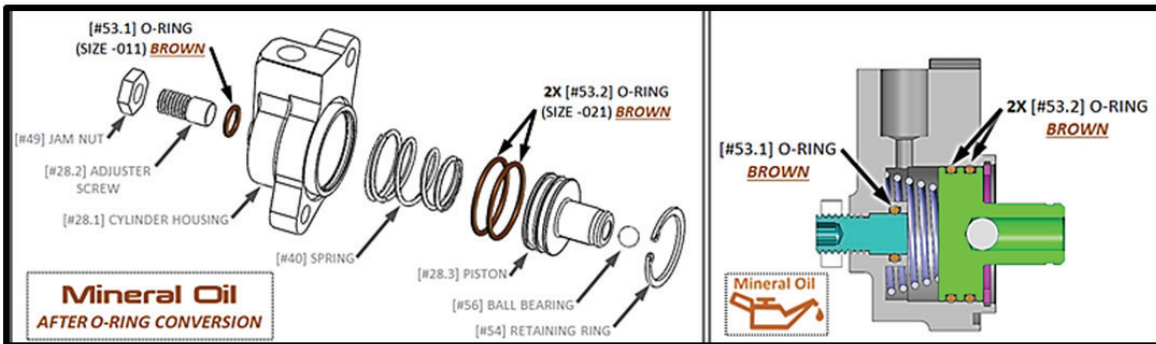
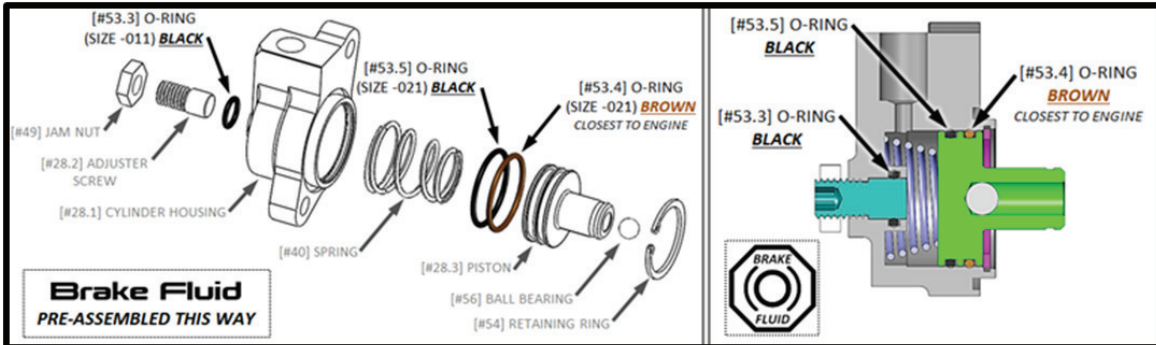

## NEWER MODEL

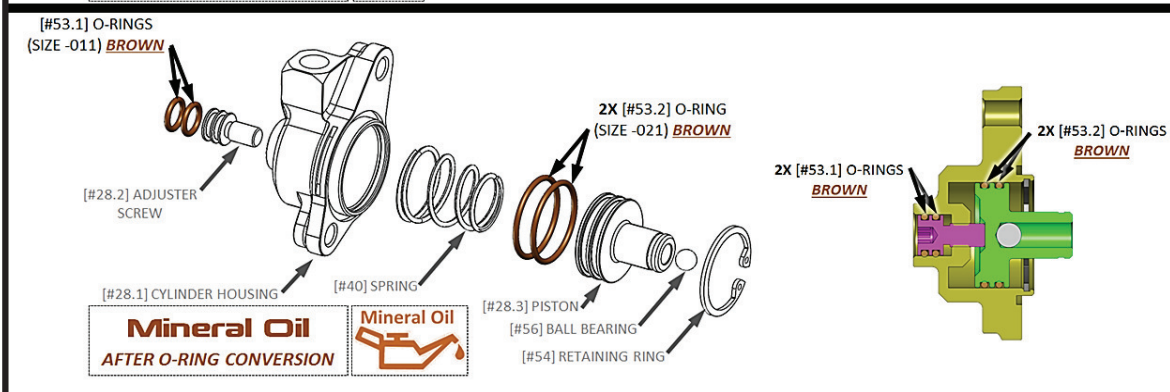
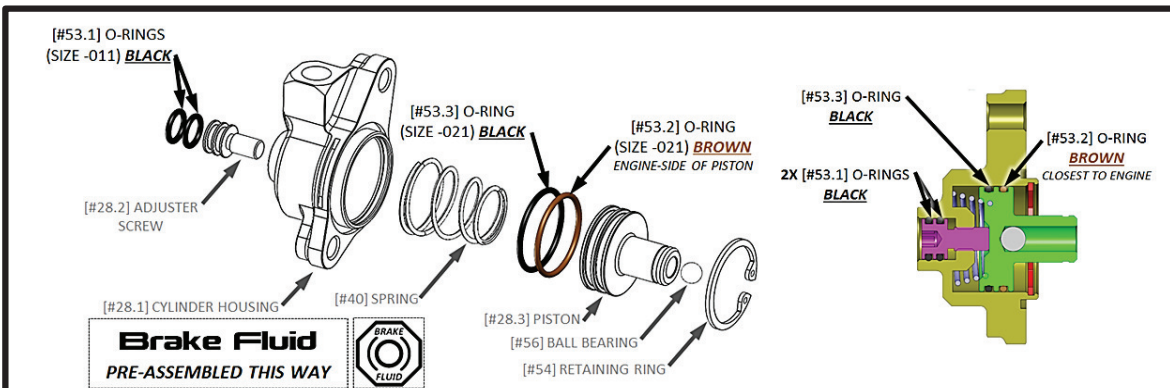

# DISASSEMBLY

1. Using snap-ring pliers, remove the snap ring from the cylinder housing.

---

2. Remove the piston assembly and spring from the housing.

---

**3. For Older Models:**

Remove the jam nut and the adjuster screw from the housing using a 4 mm hex key.

**For Newer Models:**

Remove the adjuster screw from the housing using a 4 mm hex key.

---

4. **For Older Models:** Using a dental pick tool, remove and discard the small O-ring seal from the blind groove inside the cylinder housing.

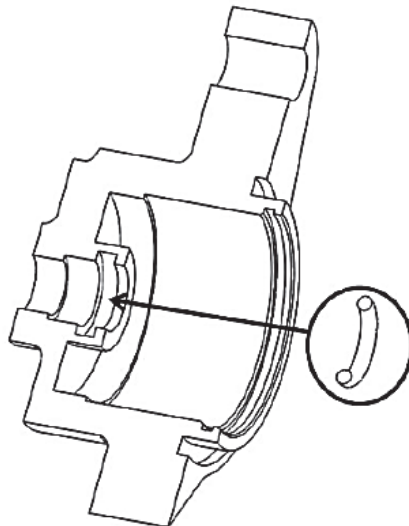

5. Using snap-ring pliers, remove the snap ring from the cylinder housing.

---

6. Remove the piston assembly and spring from the housing.

---

**7. For Older Models:**

Remove the jam nut and the adjuster screw from the housing using a 4 mm hex key.

**For Newer Models:**

Remove the adjuster screw from the housing using a 4 mm hex key.

---

**8. For Older Models:** Using a dental pick tool, remove and discard the small O-ring seal from the blind groove inside the cylinder housing.

**For Newer Models:** Using a dental pick tool, remove and discard the 2 small O-ring seals from the adjuster screw.

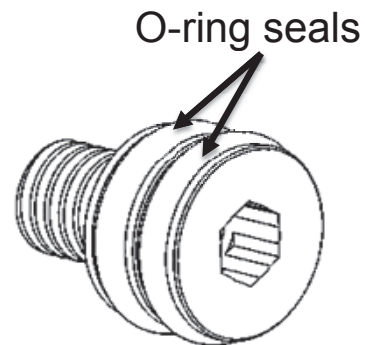

**9.** Thoroughly clean and dry the cylinder housing, piston, spring, and adjuster screw before proceeding to the reassembly phase.

---



# REASSEMBLY

1. Using the provided silicone grease packet, apply grease to all the new O-ring seals and inside the cylinder bore before reassembling.

---

2. **For Older Models:** Carefully install 1 new small O-ring seal (color depends on clutch fluid type) into the blind groove inside the cylinder housing.

- Reinstall the adjuster screw into the housing and loosely thread the jam nut onto it.

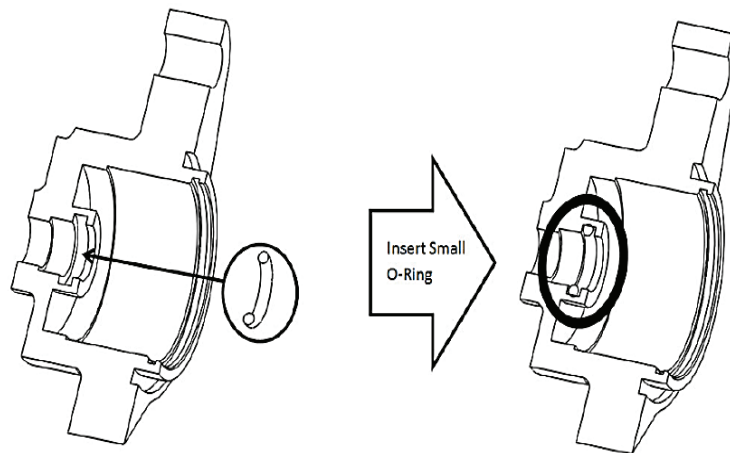

**For Newer Models:** Carefully install 2 new small O-ring seals into the grooves on the adjuster screw (these will always be the same color: either both brown or both black, depending on clutch fluid type). Then, reinstall the adjuster screw into the housing.

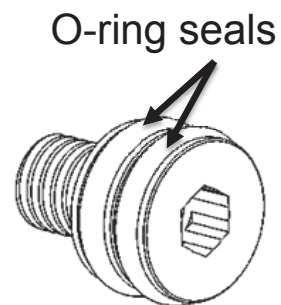

3. Carefully install the new medium-sized O-ring seals into the piston grooves.

- **For Mineral Oil Models:** Install 2 brown O-rings on the piston.

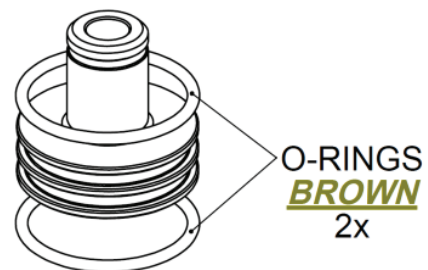

- **For Brake Fluid Models:** Install 1 brown O-ring & 1 black O-ring on the piston like shown in the diagram. *The brown O-ring **MUST** be on the piston side that faces the engine when installed.*

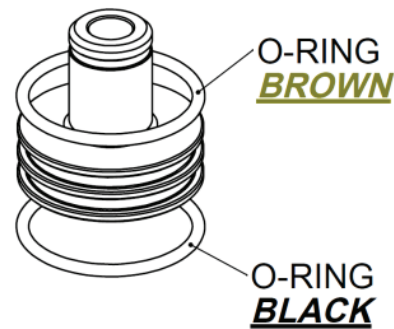

---

4. Reinstall the spring into the slave cylinder, with the wide end facing into the cylinder bore and the narrow end facing the piston.

- **For Newer Models:** Ensure that the narrow end is centered in the piston grooves as shown\*\*.

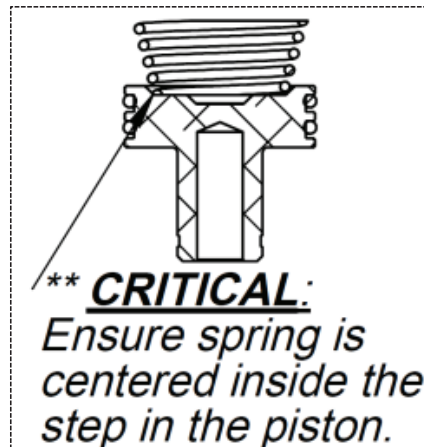

---

5. Reinstall the piston assembly into the cylinder housing using constant, gentle thumb pressure, taking care not to cut, roll, or damage the O-ring seals.

---

6. Hold gentle pressure on the piston (to keep it in place inside the cylinder bore), then reinstall the snap ring into the snap ring groove in the cylinder.



## INSTALLATION

1. Inspect to make sure that the ball bearing has remained in place inside the piston before installing the slave cylinder onto your bike.

**Note:** *If this bearing has come out, add some silicone grease to it before reinstalling it into the piston. This will help to hold it in place.*

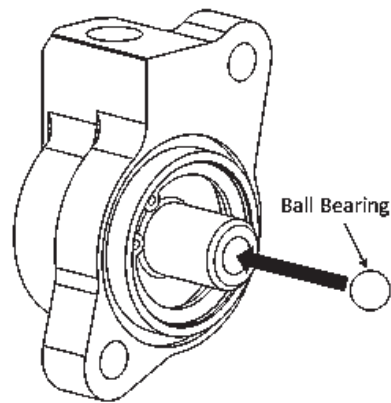

2. Reinstall the Rekluse Slave Cylinder Assembly onto the bike. Install the provided large O-ring between the cylinder and the OEM plastic spacer, then reinstall the OEM bolts.

**Note:** *This large O-ring seal will be black in color no matter the clutch fluid type.*

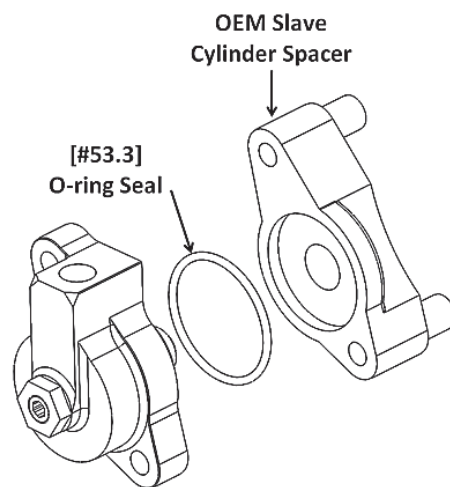

3. Refer back to your *Installation & User's Guide* document for instructions regarding bleeding the clutch fluid system, setting the Installed Gap, and making clutch adjustments.

