

CLUTCH PACK REPLACEMENT NOTES

RadiusCX Clutch Product – Cable

INSTALLATION GUIDE

The installation guide for the full RadiusCX clutch product has been provided with this clutch pack replacement kit. You will use it to install, tune, and maintain your RadiusCX clutch product.

SETUP SHEET

The setup sheet for the full RadiusCX clutch product has also been provided with this clutch pack replacement kit. You will use it to guide your clutch pack installation. The correct setup sheet for your bike is as shown:

BIKE MODEL	SETUP SHEET
CRF250R 2010+	198-7901016
CRF250R (04-09), CRF250X	198-7901012
GasGas EC 250F (10-15), EC 300F (13-15), Yamaha WR250F (01-14), YZ250F (01-13)	198-7907071
Yamaha WR250F (15-19), YZ250F (14-18), YZ250FX (15-19)	198-7907078

BASKET SLEEVES

Your clutch pack replacement kit includes new basket sleeves* to replace the used basket sleeves from your RadiusCX clutch. Be sure to use the new basket sleeves provided with the clutch pack kit for best performance.



RESETTING THE INSTALLED GAP

Because your new clutch pack may be slightly different in total thickness than the used clutch pack, perform the “SETTING THE INSTALLED GAP” and “CHECKING FREE PLAY GAIN” sections of the RadiusCX installation guide after installing the new clutch plates.

BREAK-IN

Follow the break-in procedure after the new clutch plates are installed in your bike/ATV. Do this anytime the clutch plates, EXP disk, or wedge pads are replaced.

INCLUDED PARTS

Item #	Item Type	Qty
67	Steel Drive Plate	9 or 10*
69	TorqDrive [®] Friction Disk	7, 8, or 9*
70	Basket Sleeve	12‡

**Depending on model*

‡For all models except those with steel baskets (e.g. 2018 Beta 2T bikes)





INSTALLATION & USER'S GUIDE

RadiusCX Clutch
for cable-actuated bikes

Doc ID: 191-7900A
Revision: 040919

Table of Contents

OVERVIEW	3
INSTALLATION TIPS	3
TOOLS.....	4
INCLUDED PARTS	5
DISASSEMBLE CLUTCH.....	7
THE INNER HUB.....	13
Internal adjustment ring.....	13
INSTALL THE HUB	13
INSTALL THE CLUTCH PACK	15
ADJUSTMENT PREFERENCE.....	18
Set the installed gap internally	19
Lock the pin in place.....	23
INSTALL THE CLUTCH COVER	27
CHECK FREE PLAY GAIN	28
Step 1: Learn how to check Free Play Gain	28
Two Ways to Check for Free Play Gain.....	30
The Rubber Band Method.....	31
The Hand Method.....	33
Step 2: Adjust Free Play Gain.....	34
Step 3: Break in the new clutch.....	36
LEVER SAFETY STRAPS	39
MAINTENANCE.....	39
Disk inspection examples.....	41
TROUBLESHOOTING	42
Performance issues.....	42
Clutch noise.....	42
Locking pin O-ring	43
EXP TUNING OPTIONS	43
Changing the EXP springs	44
BUMP-STARTING: Internally Adjusted	46
CLUTCH LEVER OPTIMIZATION.....	47
Optimization with OE Perch Adjuster	47
Optimization with Rekluse Adjustable Reach Lever	48
APPENDIX A	49

Set the installed gap externally	49
BUMP-STARTING: Externally Adjusted	54
NEED ADDITIONAL HELP?	55

OVERVIEW

This kit replaces many of the OE (Original Equipment) clutch parts. The following is a summary of what is replaced:

- This kit will replace all the OE frictions and drive plates with a Rekluse thin friction EXP clutch pack.
- The OE pressure plate springs will also be replaced with high quality Rekluse springs.
- OE center clutch and pressure plate components will be replaced with Rekluse Core components.
- OE basket can be re-used if tang and damper are in good condition











INSTALLATION TIPS

- Read the separate included Safety Information document before operating the vehicle with the product installed.
- Read this entire document before performing any steps.
- If you install this product for a customer or another person, instruct them to read the **Safety Information** document and the **Installation and User Guide** before operating the bike with the product.
- The RadiusCX clutch can be adjusted in 2 ways, internally or externally. Both ways have advantages. See the section on adjusting the installed gap for more information.
- Protect eyes and skin – wear safety glasses and work gloves.
- Lay the motorcycle on its left side when replacing the clutch. This makes the clutch work easier and eliminates the need to drain the oil. Catch any fuel that may drain from the bike.



- Use the torque values listed in the instructions. Otherwise, use the torque specifications found in your OE service manual.
- For optimal clutch performance Rekluse recommends using fresh, clean oil that **meets JASO-MA** oil rating requirements. Rekluse offers Factory Formulated Oil™ developed specifically for Rekluse products. Rekluse Factory Formulated Oil is a perfect complement to any OEM or aftermarket wet clutch. Visit www.rekluse.com to learn more.
- Inspect your OE cable for fraying and replace if needed.

TOOLS

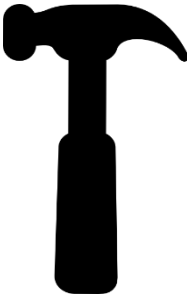
 10 mm	 8 mm		
10 mm socket	8 mm socket	Metric Wrench	Torque Wrench
			
Pick	Flat blade screwdriver	Marker	Channel lock pliers
	 5 mm		
Socket to remove clutch nut	5 mm Hex key	Hammer	

INCLUDED PARTS

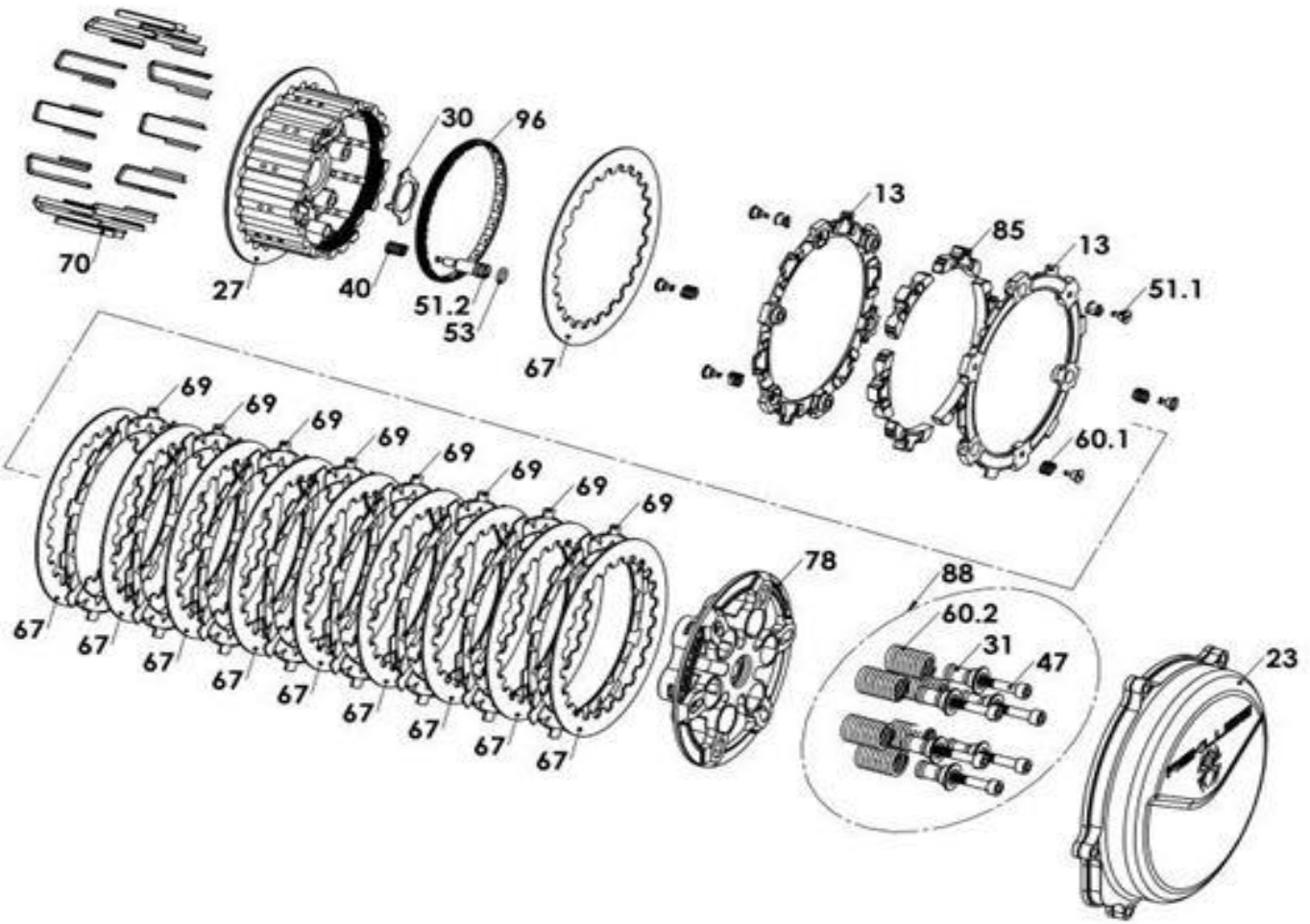

Item	Description	Qty.
13	EXP 3.0 base	2
23	Clutch cover	1
96	Hub adjuster ring	1
27	Center clutch hub - RadiusCX/Core	1
30	Core center clutch tab lock washer	1
40	CX hub coil spring	1
51.1	Quarter-turn pin, EXP	6
Not shown	Extra quarter-turn pin, EXP	2
51.2	Quarter-turn locking pin, CX hub	1
53	Viton O-ring	1
Not shown	Black rubber band for Free Play Gain	1
60.1	EXP adjustment spring (See EXP tuning options)	6
Not shown	EXP adjustment spring (See EXP tuning options)	3
Not shown	EXP adjustment spring (See EXP tuning options)	3

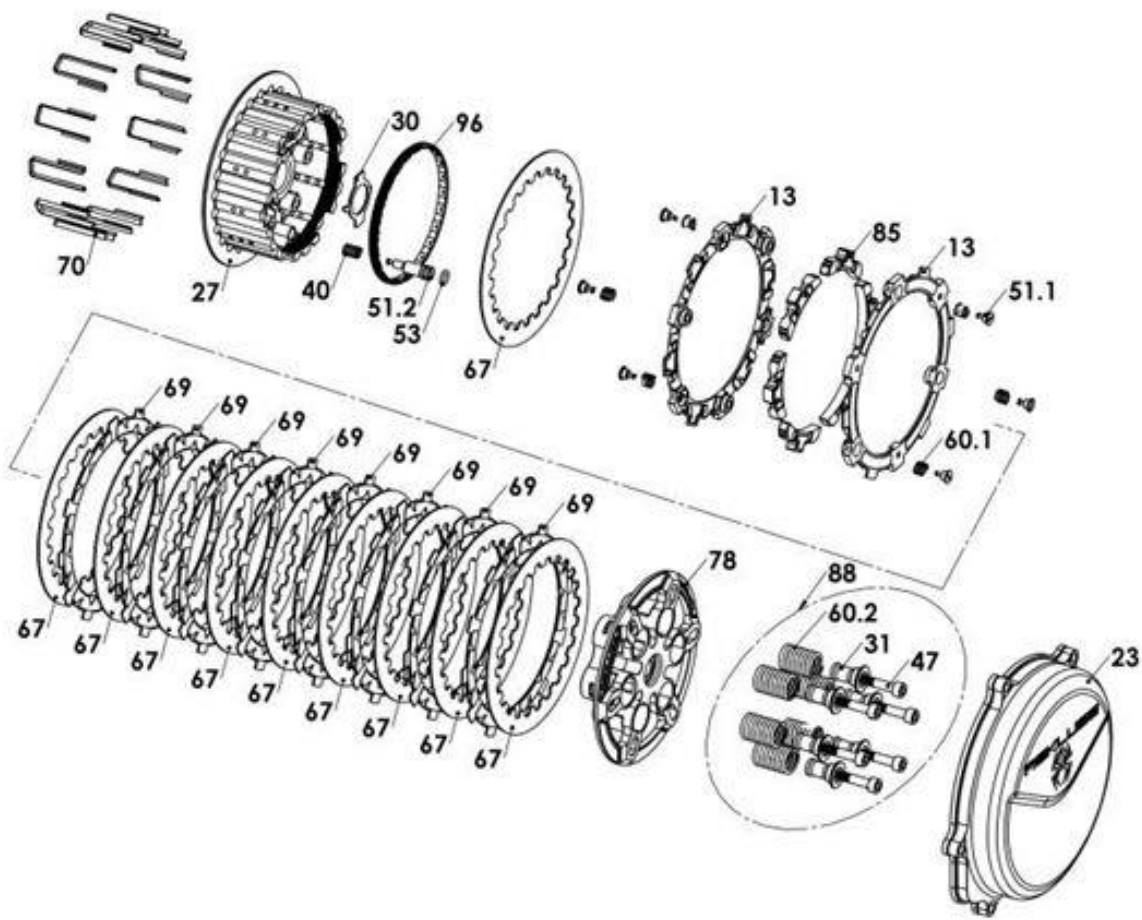

67	Steel drive plate	10
69	TorqDrive [®] friction disk	8
70	Basket sleeve - dirt bikes	12
78	Pressure plate assembly - RadiusCX	1
85	EXP 3.0 wedge assembly	6
88	Core clutch spring kit	1
31	EXP screw sleeve	5 or 6
47	Socket head cap screw	5 or 6
60.2	Pressure plate spring	5 or 6
Not shown	Permanent Marker: for initial adjustment	1
Not shown	Extra Viton O-ring	1
Not shown	Velcro Strap	1
Not shown	Clutch cover O-ring cord**	1
Not shown	Perch adjuster bolt**	1
Not shown	Throw-out assembly**	1
Not shown	Throw-out spacer washer**	1

**Some models only

Visit www.rekluse.com/support for a full parts fiche illustration and part numbers.

DISASSEMBLE CLUTCH

1. If your bike is carbureted, turn the fuel petcock to “OFF.”
2. Shift the transmission into 5th gear.
3. Lay the bike on its left side. Catch any fuel that might drain in a suitable container.

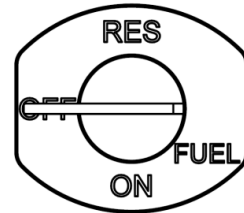

4. If your clutch cover has an oil fill plug and/or an engine inspection plug, loosen them before removing the clutch cover.

NOTICE

Clean and set aside the OE cover gasket. The cover gasket will be reused.

5. Using an 8 mm socket, remove the OE clutch cover. Pay close attention to the length and location of the OE screws so they can be returned to their same location.

6. Using a socket, remove the pressure plate screws and springs, then remove the pressure plate.

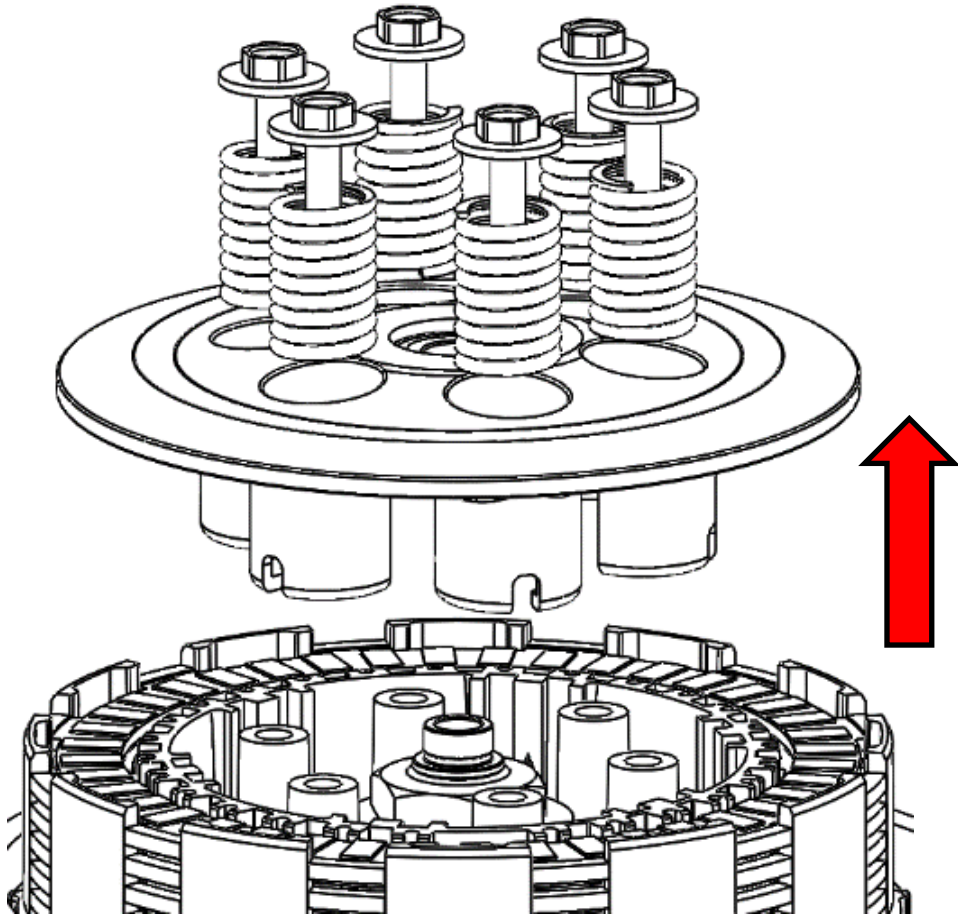

7. Remove the OE clutch pack (including the judder spring and seat), then set aside all the plates. Use a pick if necessary to help remove all of the plates.

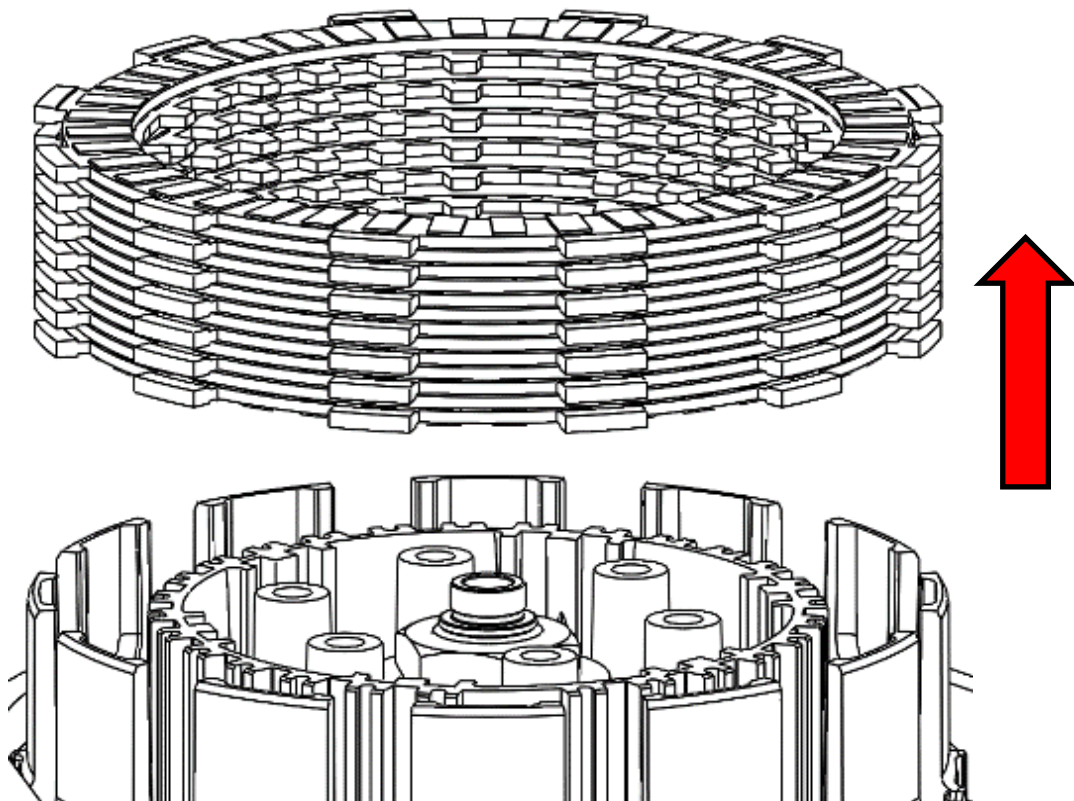

8. Inspect the clutch basket for damper/cushion play or notching. Do not install sleeves or use product with a notched basket. Notched basket tang faces or worn dampers can cause the sleeves to break.

⚠ WARNING

Failure to inspect the basket and replace if necessary could result in death, serious injury, and/or property damage.

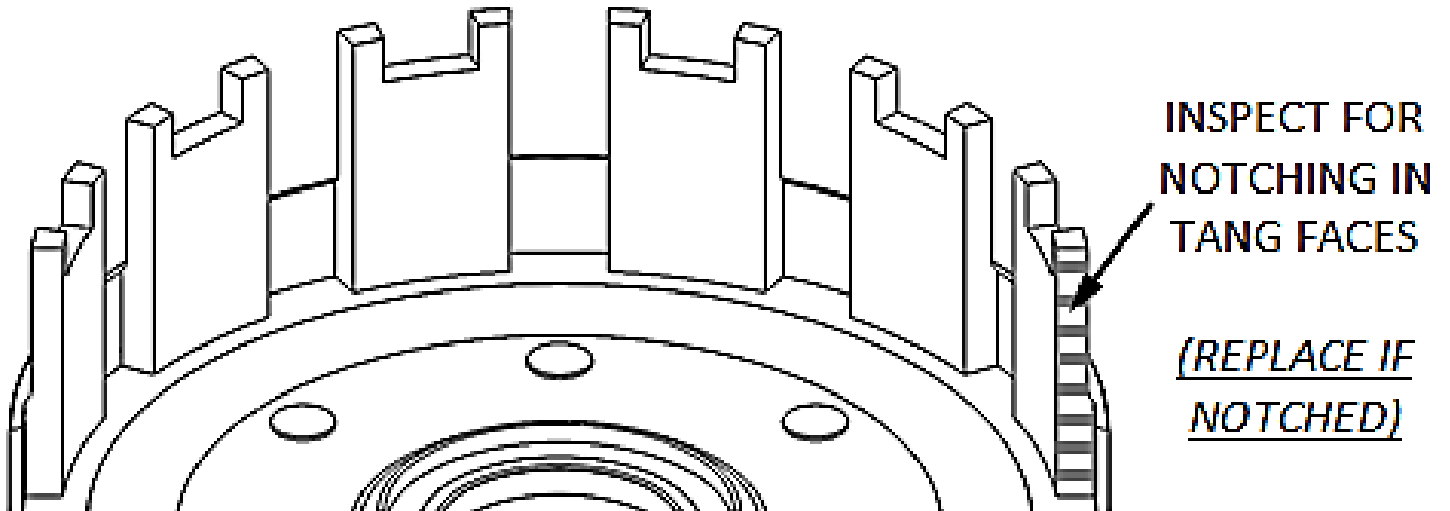

NOTICE

If the basket is notched or worn, Rekluse recommends replacing it with a Rekluse Billet Clutch Basket (available for most models).



9. Remove the throw-out assembly, bearing, and washer. Set these aside. These will be reused. The throw-out assembly may look different depending on the bike.

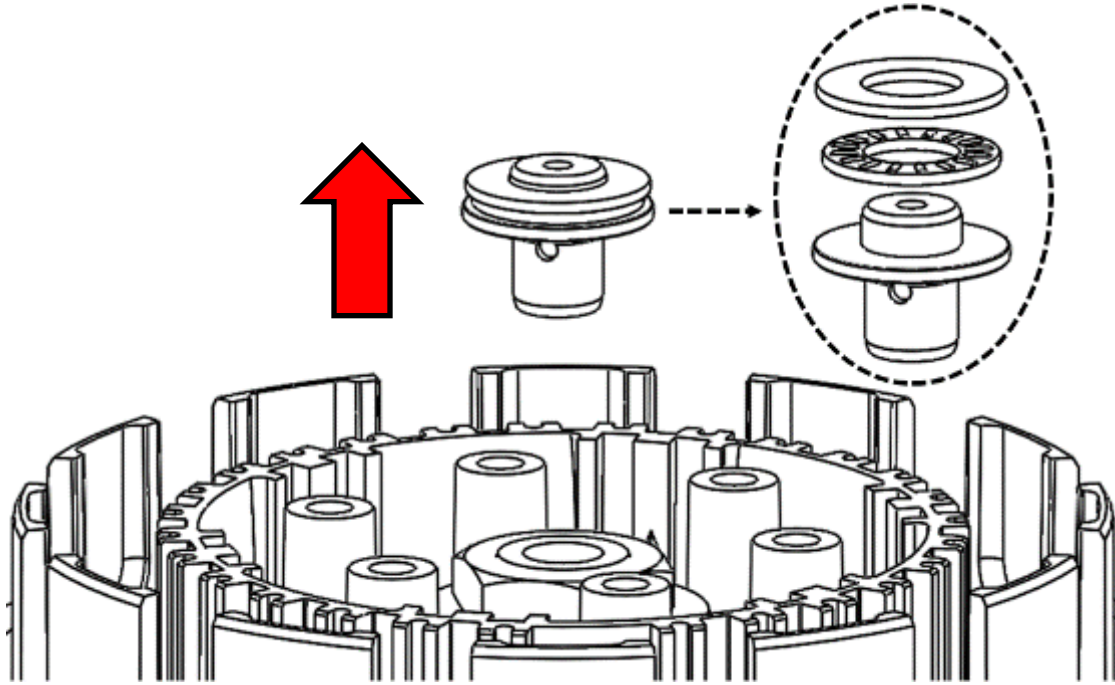

10. Use a hammer and large screwdriver to bend down the edges of the washer tab until it clears the clutch nut. The washer may look different depending on the bike.

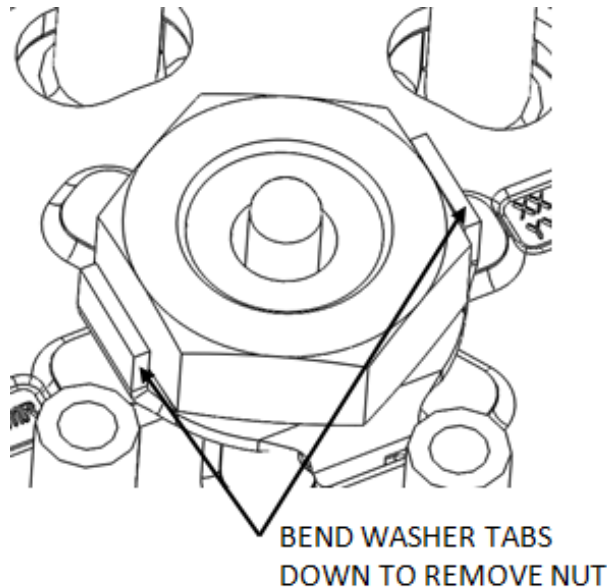

11. Remove the center clutch nut with an impact wrench or breaker bar, and socket. Set aside. The OE clutch nut will be reused.

NOTICE

Placing the bike in the highest gear and holding the rear wheel by applying the rear brake keeps the shaft from rotating when removing the nut.

12. Remove the washer(s) located under the center clutch nut. The OE washer(s) will be replaced with a Rekluse tab lock washer.

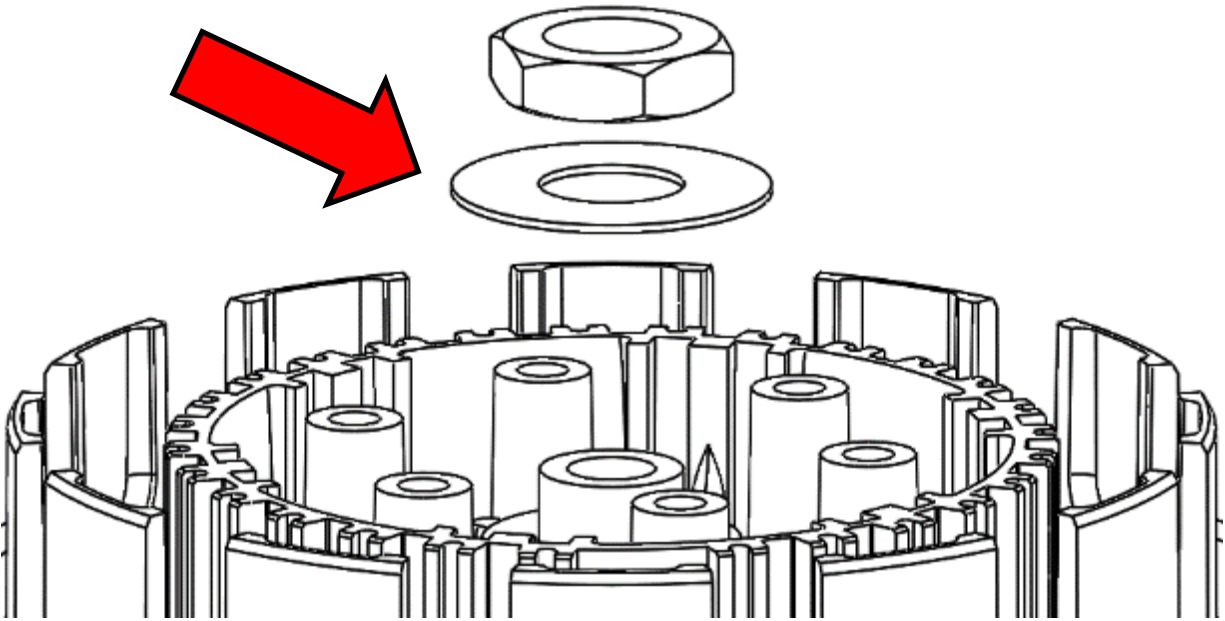

13. Remove the center hub from the clutch basket while leaving the underneath thrust washer on the main shaft.

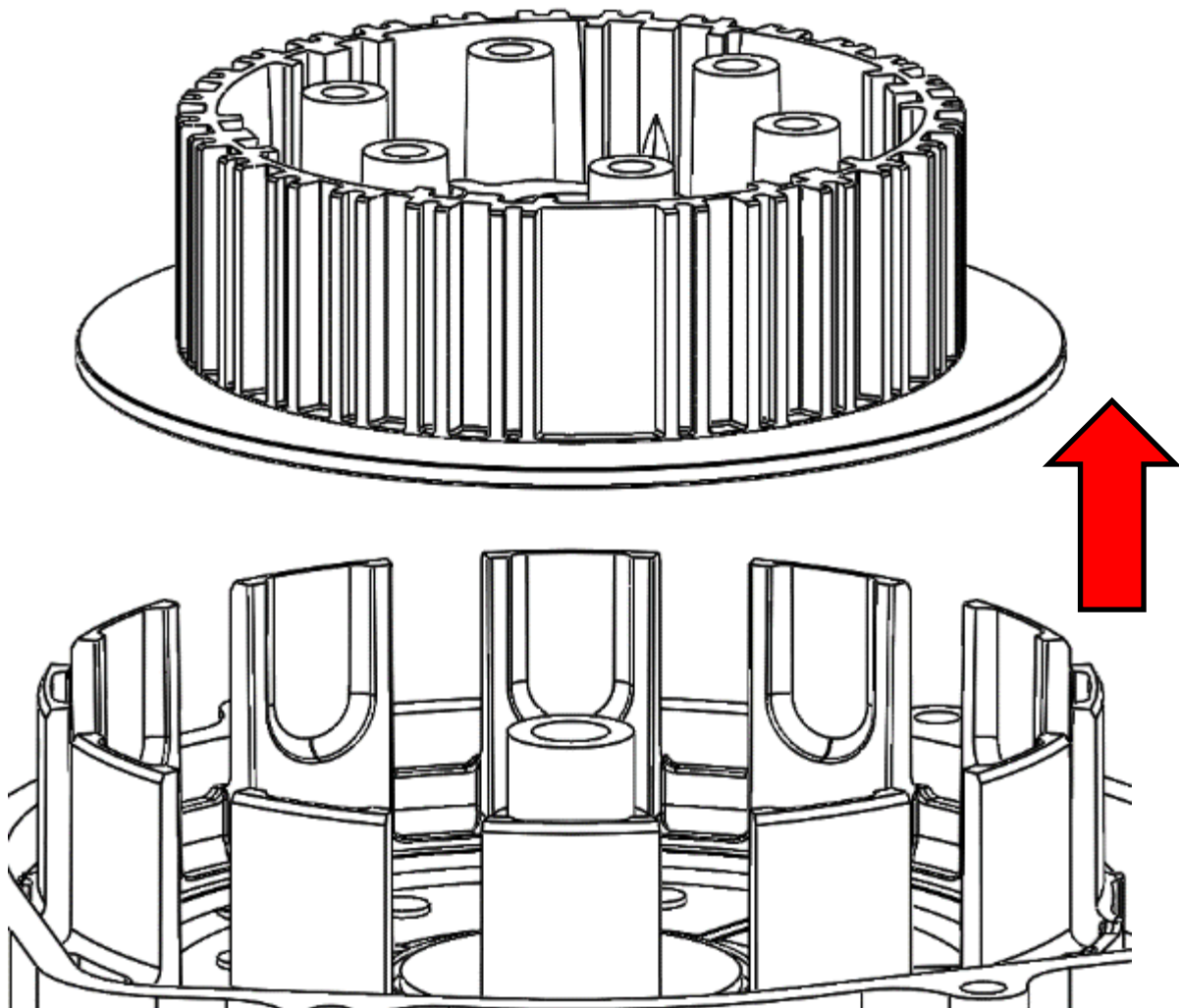

NOTICE

Check that the OE thrust washer is still on the main shaft and not stuck to the bottom of the center hub assembly. The thrust washer must be installed or clutch performance issues will result.

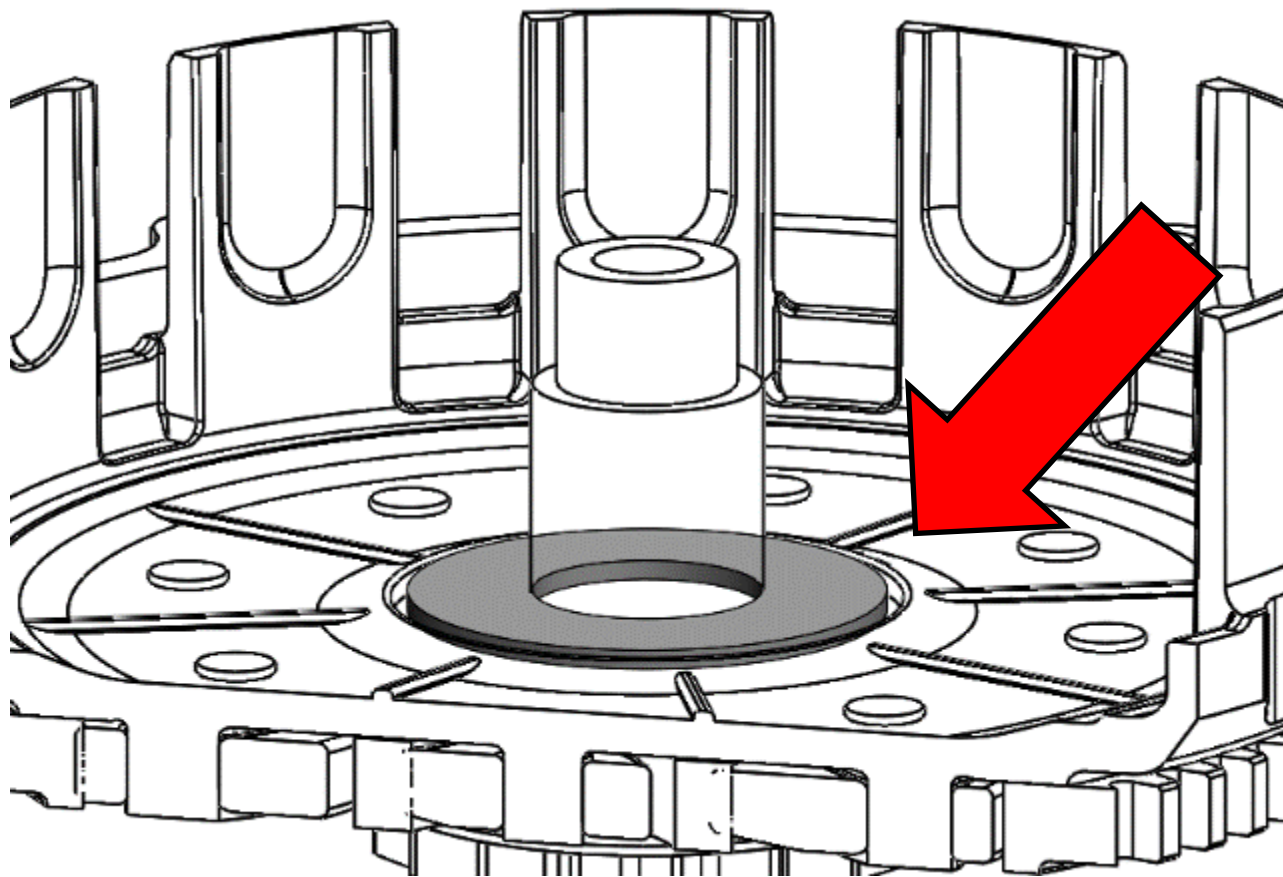

THE INNER HUB

Internal adjustment ring

The internal adjustment ring comes installed in the Rekluse hub. The adjustment ring has circle detents and notches cut into it to help with the adjustment.

Adjustment notches are small, and are cut halfway down the ring. They are used to help turn the ring during the adjustment.

Circle detents are larger, and used to position the locking pin when unlocking and locking the adjustment ring.

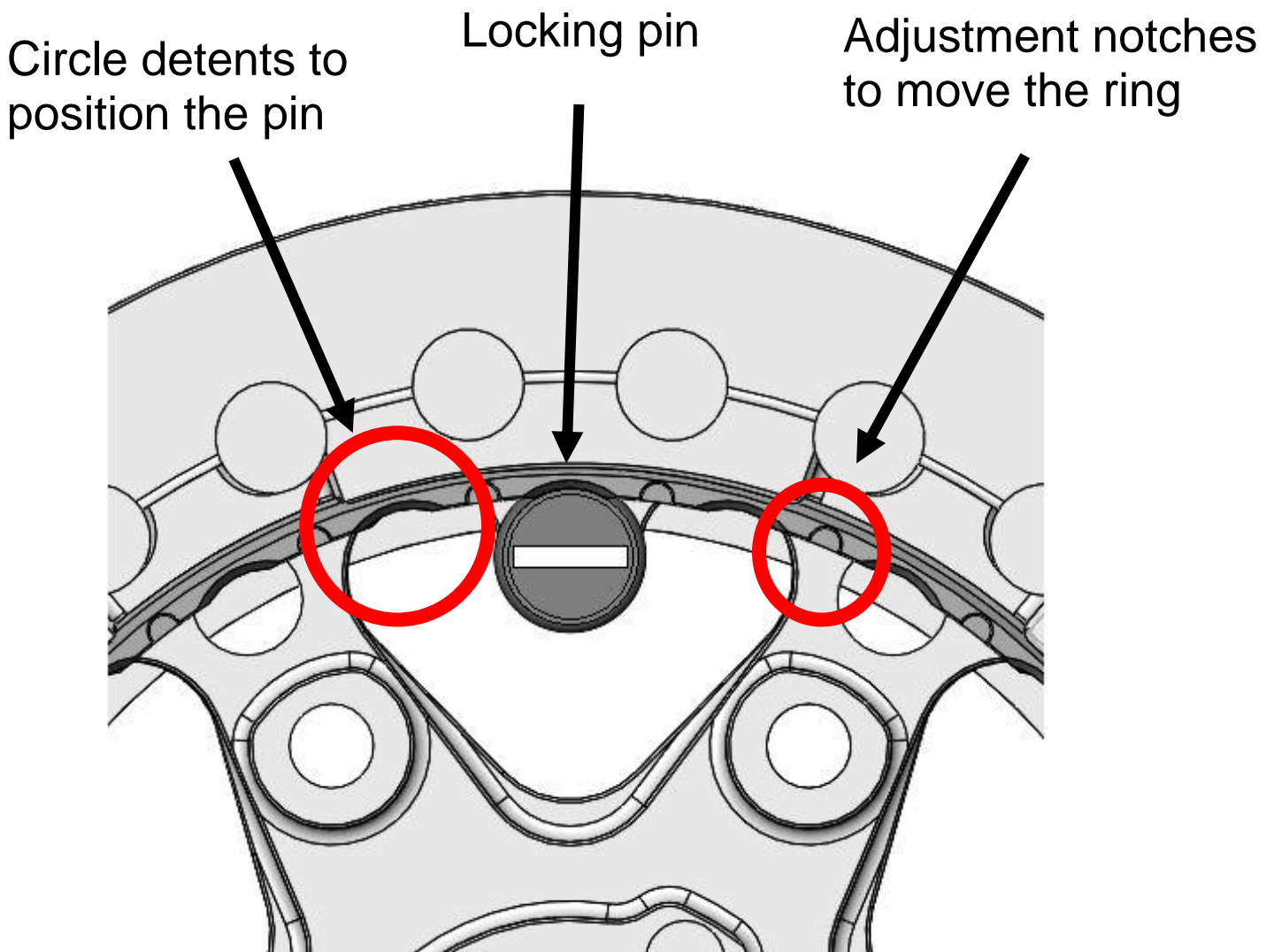

INSTALL THE HUB

1. Install the new Rekluse center hub into the clutch basket. Check to make sure the OE thrust washer is still on the main shaft before you install the hub.

2. Install the new Rekluse tab washer with the bent tabs facing down, aligning with the holes in the hub.

3. Install the OE clutch nut.

4. Using the socket and torque wrench, torque the center clutch nut to **50 ft-lb (68 N-m)**.

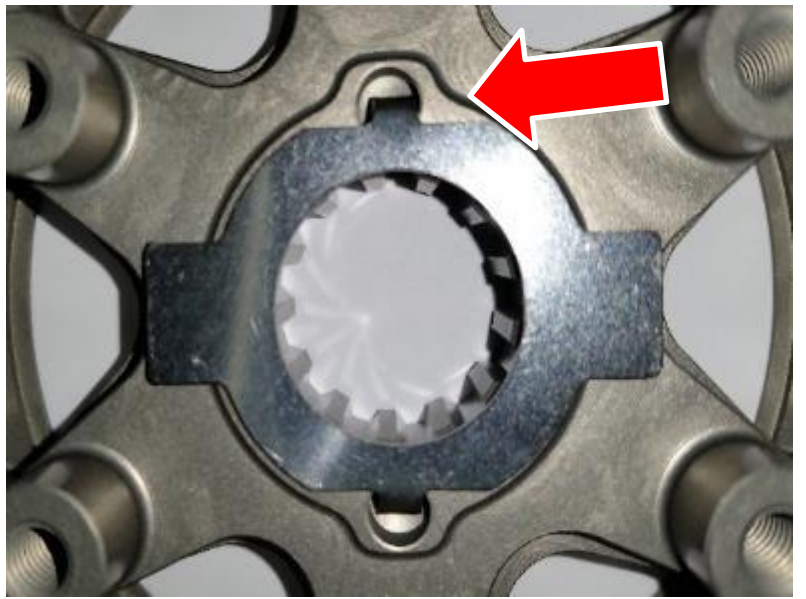

NOTICE

Placing the bike in the highest gear and holding the rear wheel by applying the rear brake keeps the shaft from rotating when tightening the nut.

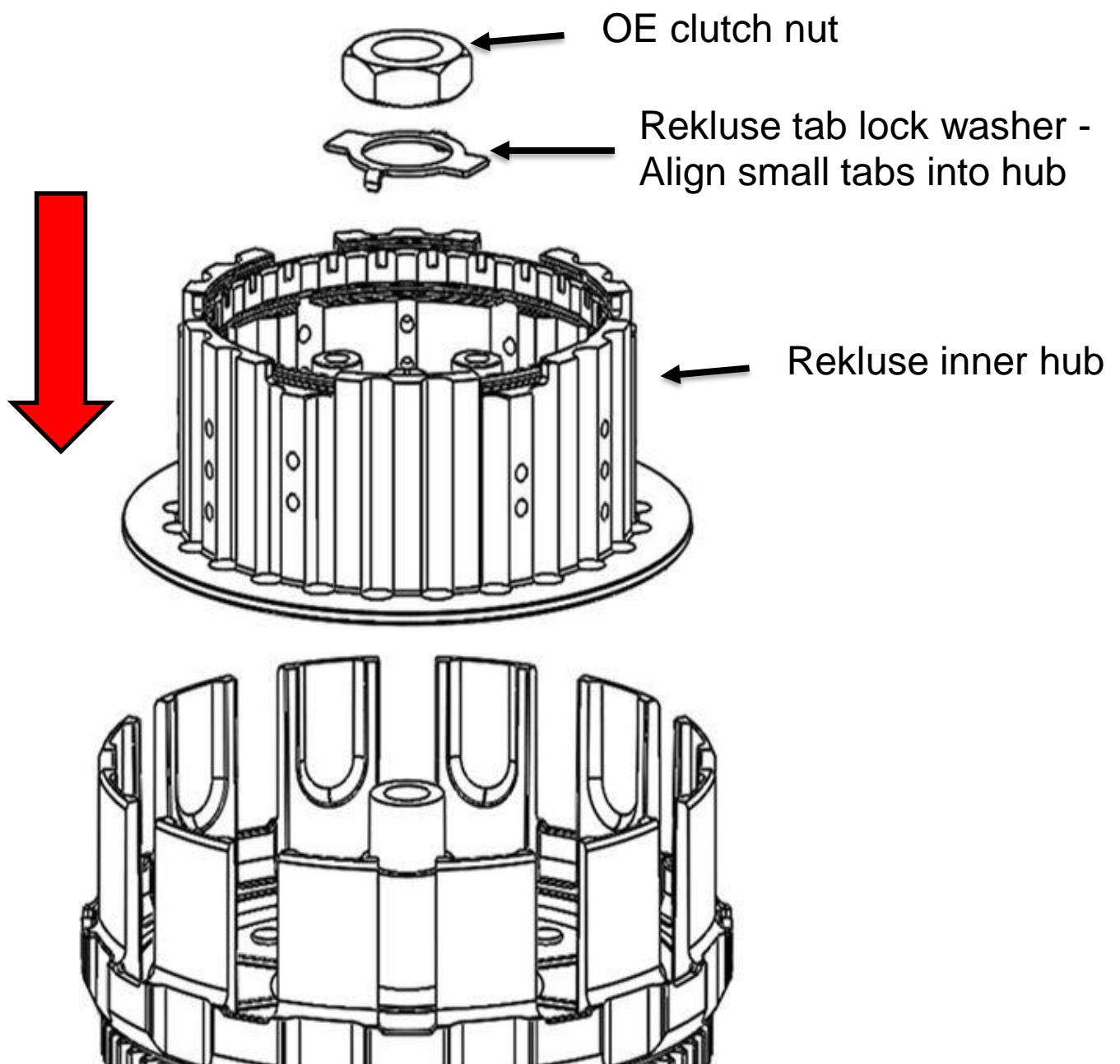

- Using the channel-lock pliers, bend up **both** tabs of the tab washer tightly around the nut. The tabs can be bent on the straight sides or around the corners.

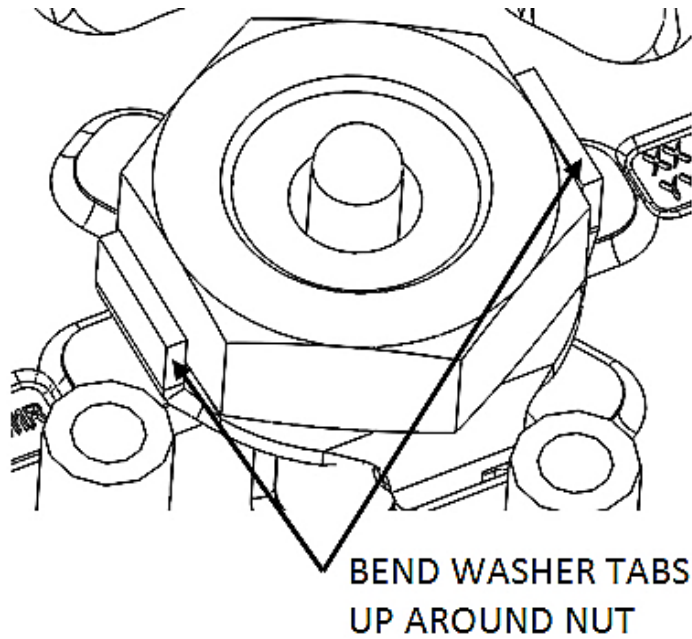

INSTALL THE CLUTCH PACK

Each clutch pack comes with a set of steel plates, a set of friction disks, and an EXP disk. The specifics of the clutch pack depend on the bike. The height of the assembled clutch pack and specific information for each bike can be found on the **Setup sheet at the back of the Installation Manual**.

- Soak the EXP disk and TorqDrive[®] friction disks in engine oil for 5 minutes. Make sure the EXP and friction disks are coated in oil on both sides.

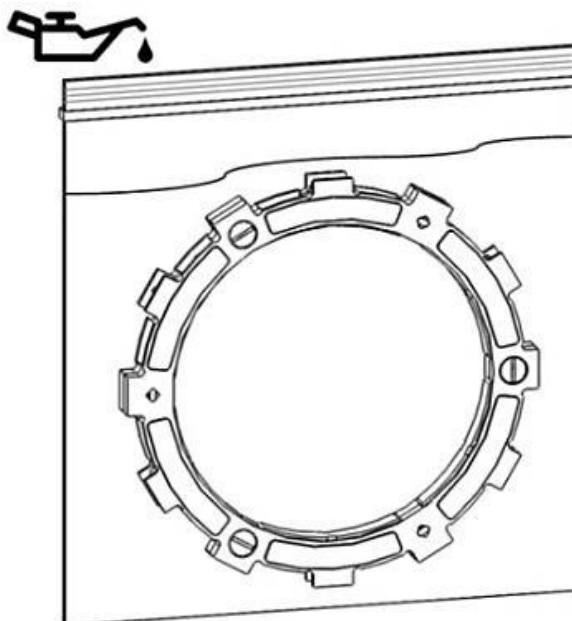

2. Install all the Rekluse basket sleeves into the basket slots. Make sure the bottom of the sleeve is facing down, and the sleeve tabs sit against the inside of the basket. (See pictures for reference.)

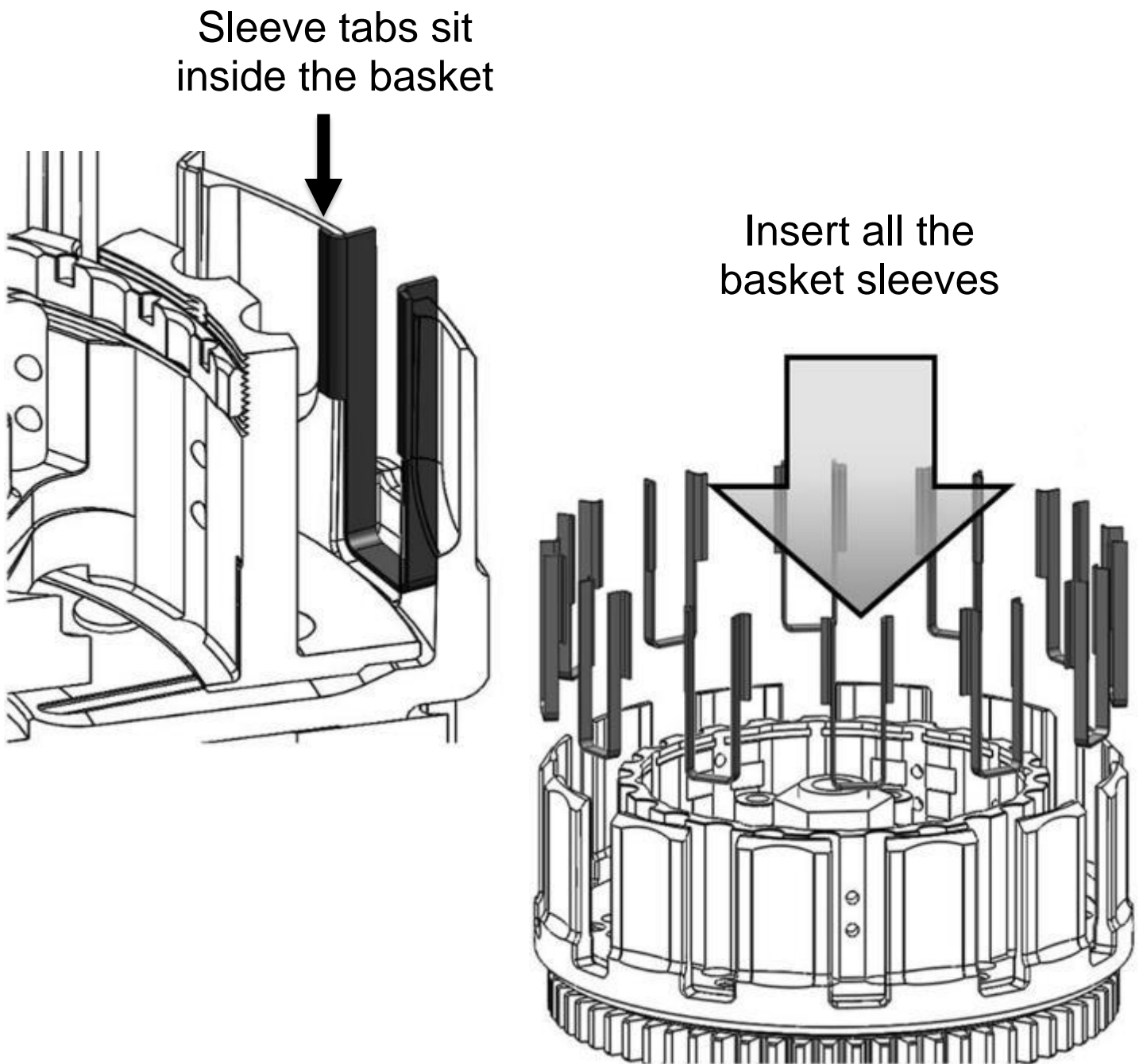

NOTICE

When seated in the basket, the sleeves may stick above or below flush with the top of the basket depending on the bike model. This is normal.

3. Install one steel drive plate onto the center hub first, followed by the EXP disk. *The judder spring and seat are not reinstalled.*

4. Add another steel drive plate on top of the EXP disk, then add a friction disk.
5. Continue alternating the steel drive plates with the friction disks for the entire Rekluse clutch pack, ending with a steel drive plate on top. *If the basket sleeves fall forward while installing the clutch pack, use a pick to push the basket sleeves back into place.*

NOTICE

The number of friction disks and steel plates that make up the clutch pack can be found on the **Setup Sheet at the back of the Installation Manual**. Some friction disks are marked with colored markings. These marks are used for processing and can be ignored.

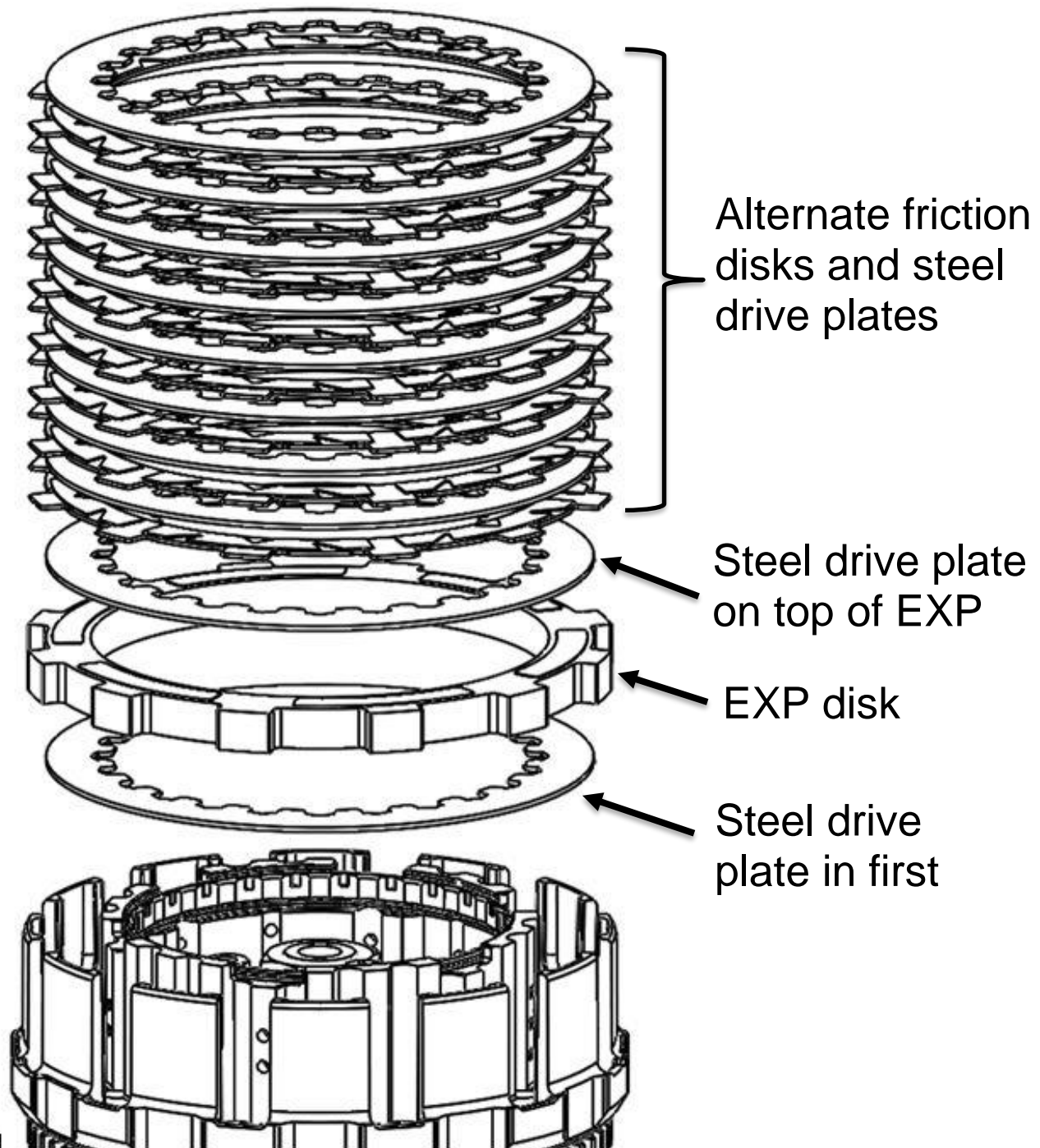

ADJUSTMENT PREFERENCE

The installed gap for the RadiusCX clutch can be adjusted in two ways. It can be adjusted internally by turning the adjuster ring, or externally by adjusting the dial at the perch. Choose the way you adjust the installed gap based on your riding preference.

If you want to maintain stock lever feel and stock lever free play, then adjust the gap internally. If you would like the advantage of adjusting at the perch, then adjust the gap externally. Rekluse recommends beginning with the internal adjustment using the adjustment ring to produce an experience close to stock. To adjust the gap externally, see **APPENDIX A** for instructions.

Adjustment Comparison

Internal External

	Internal	External
Stock lever feel	✓	*
Stock lever reach	✓	*
Maintains lever free play (slack) like stock	✓	
Eliminates lever freeplay (slack), delivering a quick and responsive lever feel		✓
Quick install gap adjustment at the perch		✓
Allows external removal of installed gap for bump starting		✓
Lever override less sensitive to gap setting		✓

*An adjustable reach lever allows the lever starting point to be tuned much like the way lever free play is often used for this with a stock clutch.

Set the installed gap internally

1. Install the pressure plate onto the clutch pack.

NOTICE

Do not install the throw-out for this step. In order to successfully set the gap internally, we do not use the throw-out for the initial setting. It will be installed in a later step.

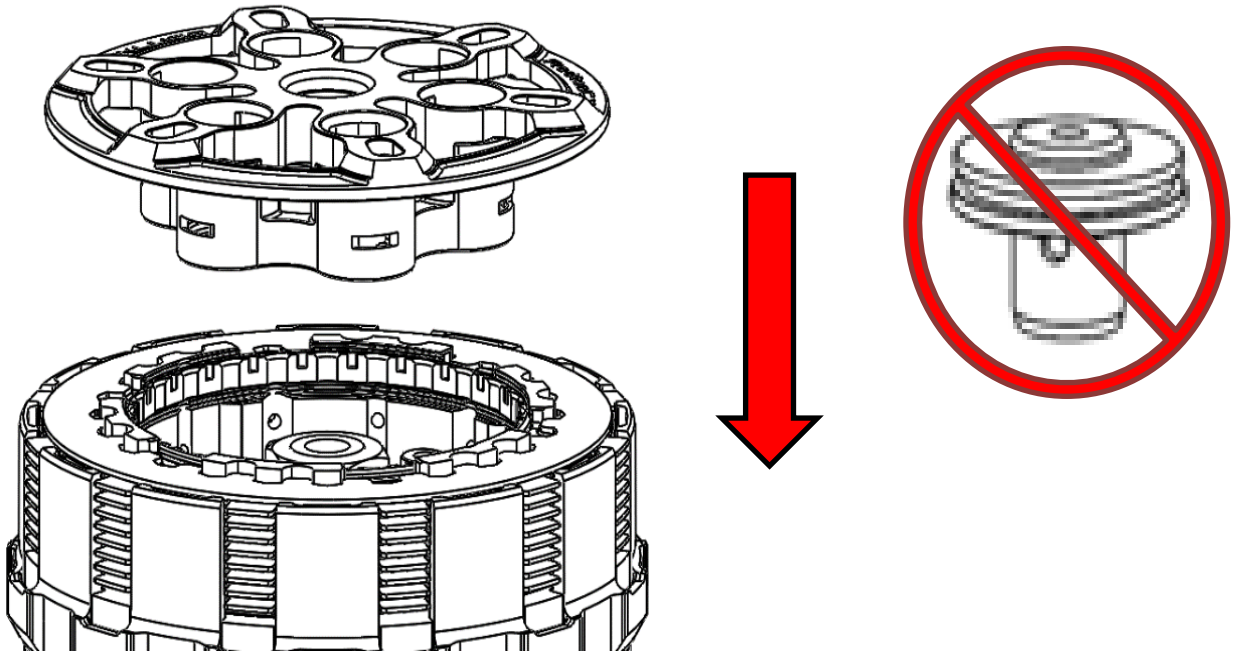

2. Using every other spring cup, insert 3 of the pressure plate springs followed by 3 screw sleeves.

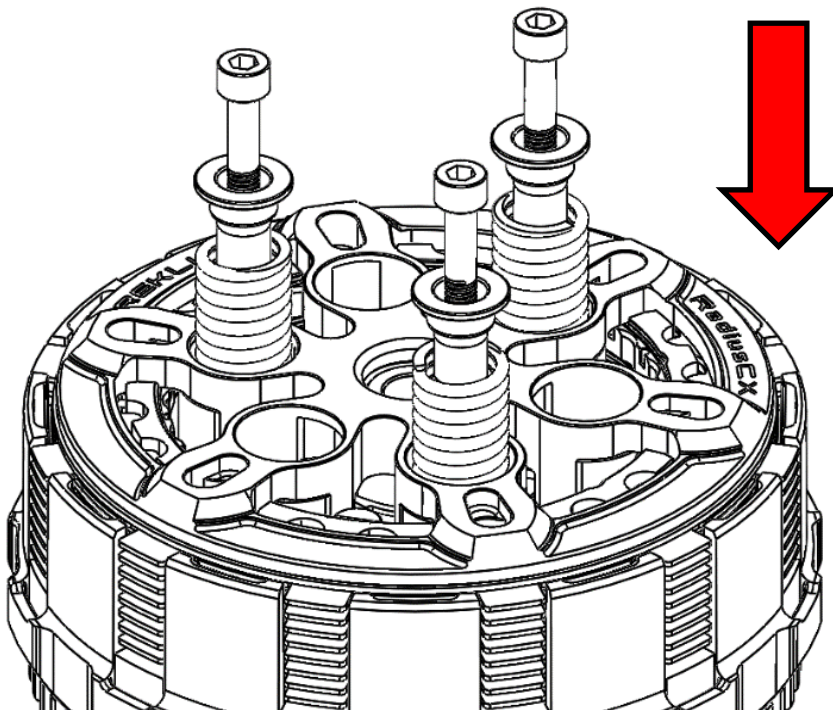

250F bikes only (excluding 19+ YZ250F):

Install all 5 springs, screw sleeves, and bolts to keep even pressure on the pressure plate.

3. Insert the pressure plate bolts into the screw sleeves. You will add the additional screws later after adjusting the installed gap.
4. Tighten the bolts until snug. They will be removed in a later step.
5. Using a flat blade screwdriver, push the ¼-turn pin down, then turn it a quarter of a turn and slowly release pressure on the pin, allowing the spring to push it up. When unlocked, the adjuster ring will be able to move freely without having to remove the pin from the hub.



Locked



Unlocked

⚠ CAUTION

Keep steady pressure when locking or unlocking the locking pin. The pin is spring-loaded and can fly out suddenly if released quickly.

6. Using the adjustment notches, use a screwdriver or your fingers to turn the adjustment ring counterclockwise until it comes to a stop under the pressure plate. This is your **starting point** for adjusting the installed gap.



7. Once you find the starting point, remove the pressure plate by removing the pressure plate bolts, screw sleeves, and springs.

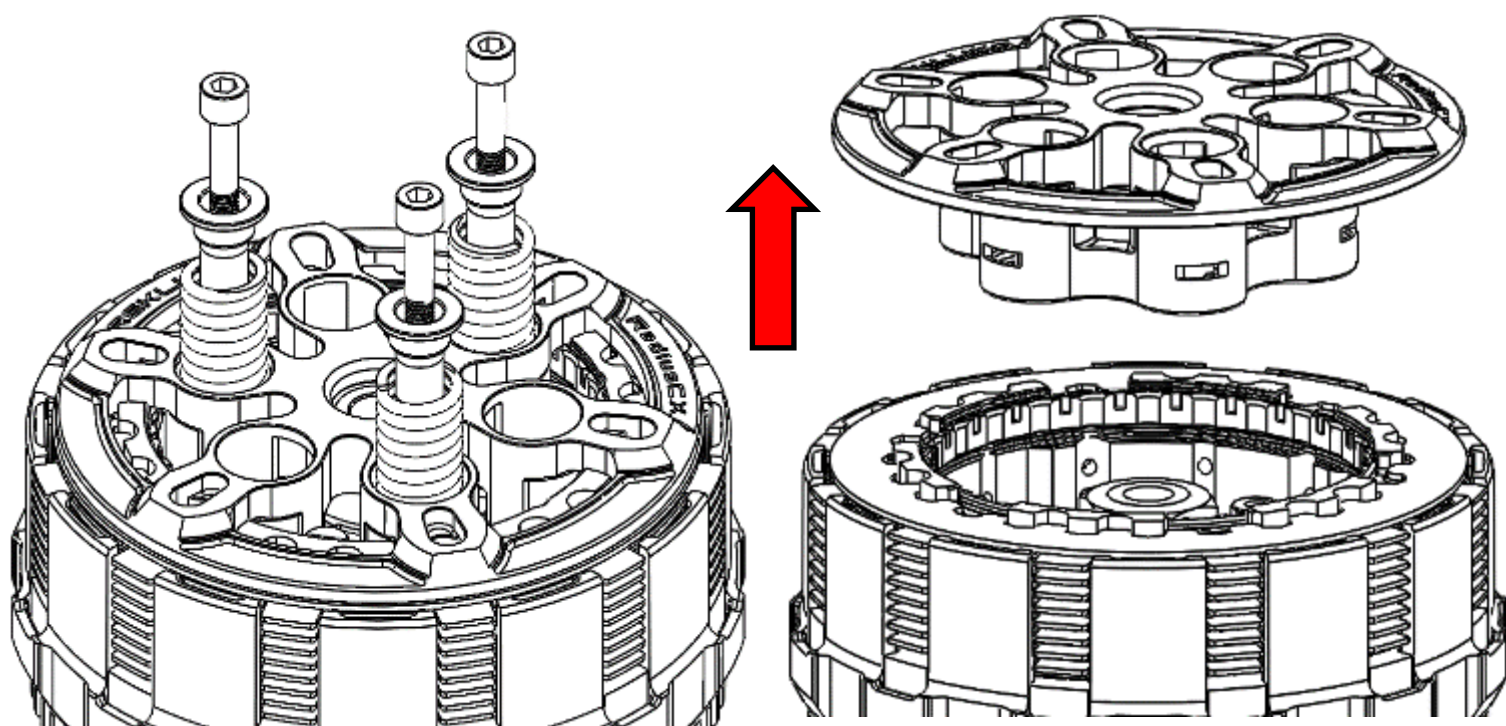

8. Choose a circle detent on the ring. Use a permanent marker (supplied) to draw a mark across the middle of a circle detent on the adjustment ring and hub.



NOTICE

It does not matter where you draw the mark as long as it is over one of the circle detents on the adjustment ring. You may need to wipe the oil off the adjustment ring and hub before marking the ring.

9. Place the tip of a flat blade screwdriver in the adjustment notch next to the mark or use your fingers to turn the inner adjustment ring **ONE FULL TURN COUNTERCLOCKWISE**, ending at the starting mark on the hub.



10. Using the mark for reference, turn the adjustment ring **counterclockwise 3 additional circle detents** past your mark on the hub.

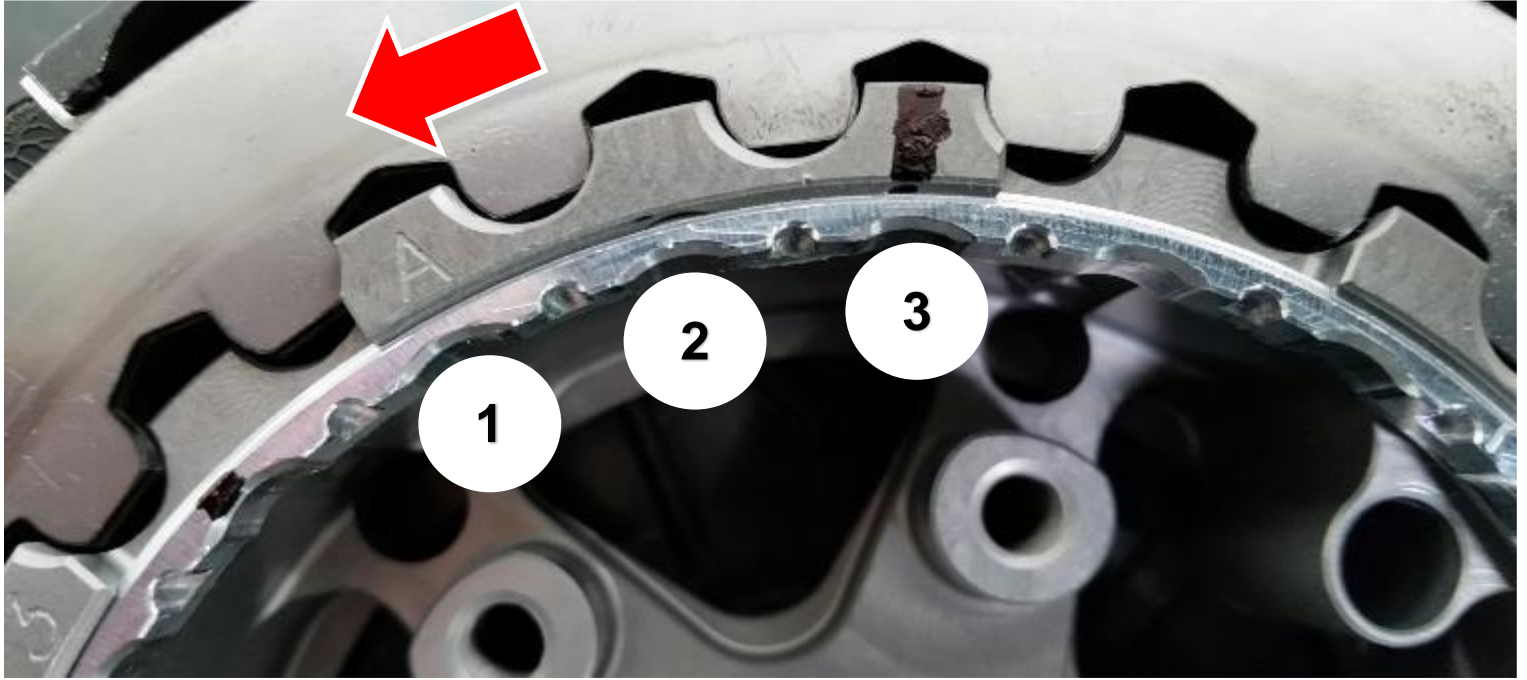

Lock the pin in place

- The quarter-turn locking pin is designed so that it is easy to identify when the pin is in the locked position.
- The pin has two grooves. A top groove with an O-ring and a bottom groove.
- To lock the pin:
 - a. Line up the pin with a circle detent and then turn the pin so the screwdriver slot is perpendicular to the adjustment ring.

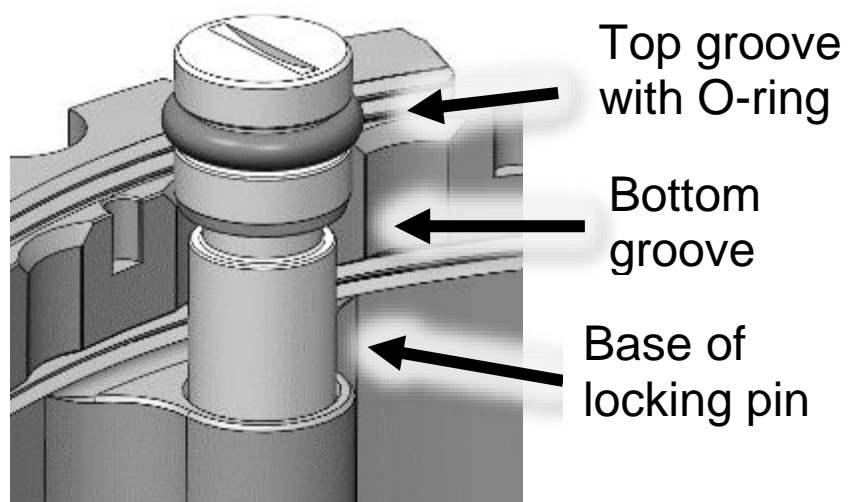
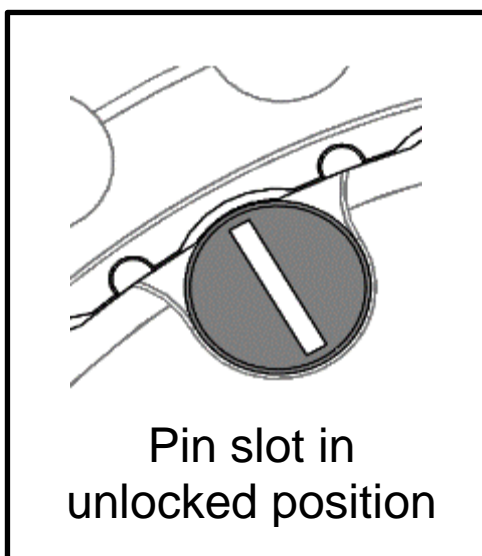

- b. Once aligned, use a screwdriver to push the pin down until the pin seats onto the hub, then turn the pin a quarter of a turn and slowly release pressure on the pin. **Do not force the**

pin down. Slightly moving it back and forth before pushing it down will help it seat into position.

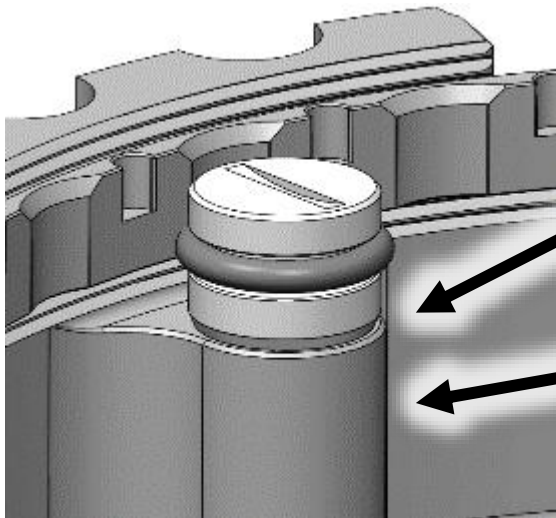

Push pin down until the pin seats onto the hub, then turn $\frac{1}{4}$ of a turn.

Hub

- c. The spring will push the pin back up once it is released. The bottom groove is visible when the pin is locked.

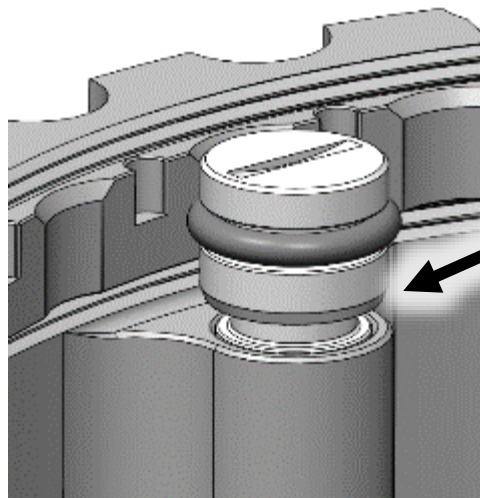
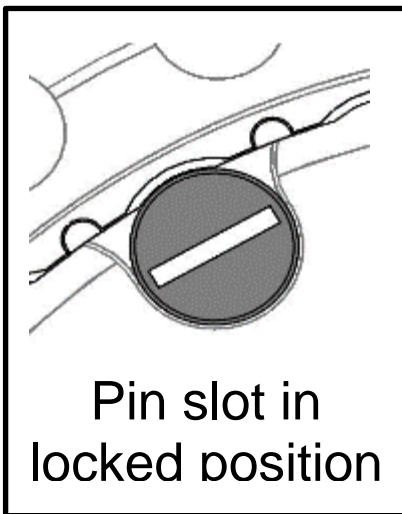

The bottom groove shows when locked correctly

NOTICE

The ring will move slightly when the pin is locked. This is normal.

CAUTION

Be sure to line up the locking pin with the circle detent before turning. Don't force the pin down. This can cause the pin to break. The pin should insert easily. Forcing the pin down can also tear the attached O-ring. The pin can get wedged if not lined up in the correct position. If it becomes wedged, GENTLY apply leverage with a screwdriver under the locking pin head while covering the pin with your hand to prevent losing the pin when released.

11. Reinstall the OE throw-out assembly, bearing, and washer. If the washer is missing, check to see if it is stuck to the underside of the pressure plate.

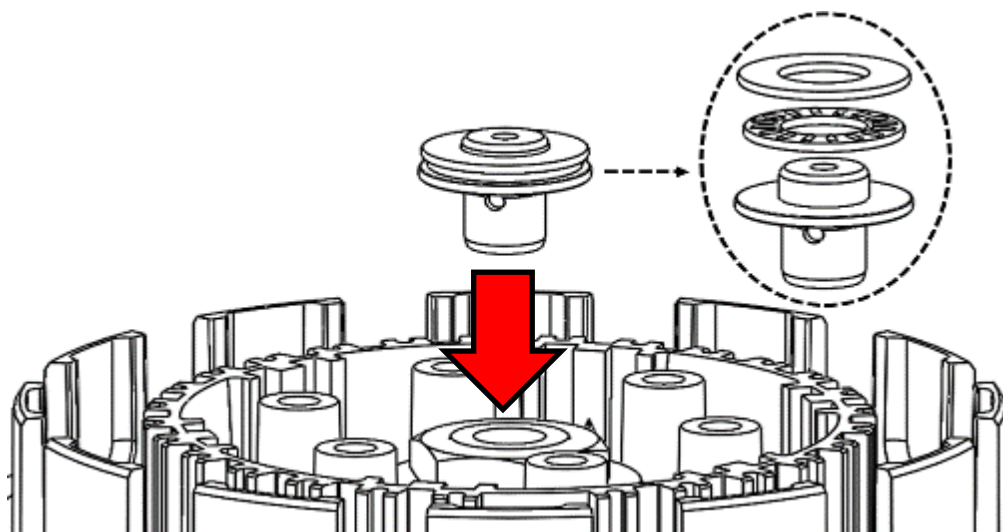

CRF250X owners:

Your kit includes a throw-out assembly that must be used in place of your OE throw-out. Install your Rekluse throw-out assembly now.

YZ125 owners:

Your kit includes an additional throw-out spacing washer to achieve correct spacing. Install the Rekluse spacing washer on top of the OE throw-out and washer.

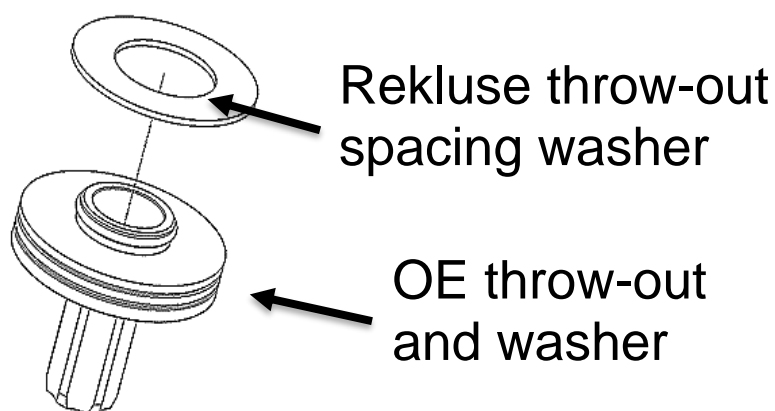

⚠ CAUTION

Suzuki RM-Z450 Models: The needle bearing only has the bearings on one side. Make sure that the bearing side is facing the throw-out and the flat side is facing the pressure plate.

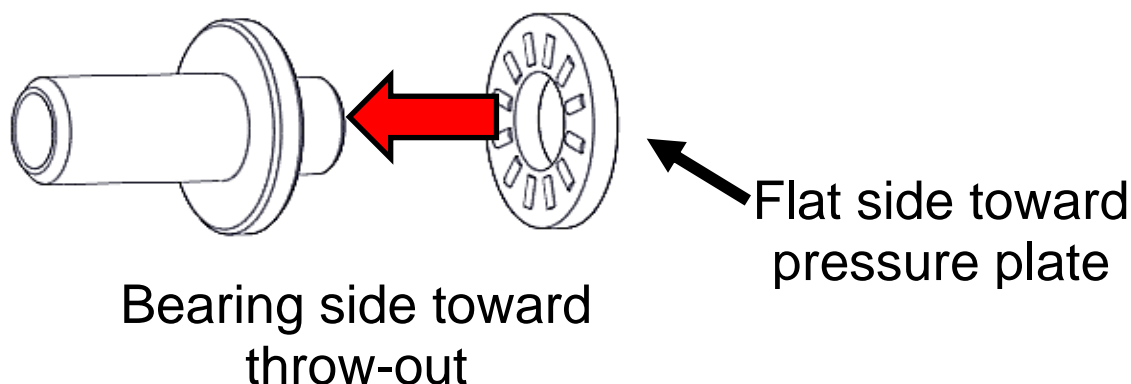

12. Reinstall the pressure plate. Insert all the pressure plate springs, then insert the screw sleeves. Insert the pressure plate bolts into the screw sleeves.

CAUTION

Do not reuse the OE springs or bolts. They will cause interference with the clutch cover!

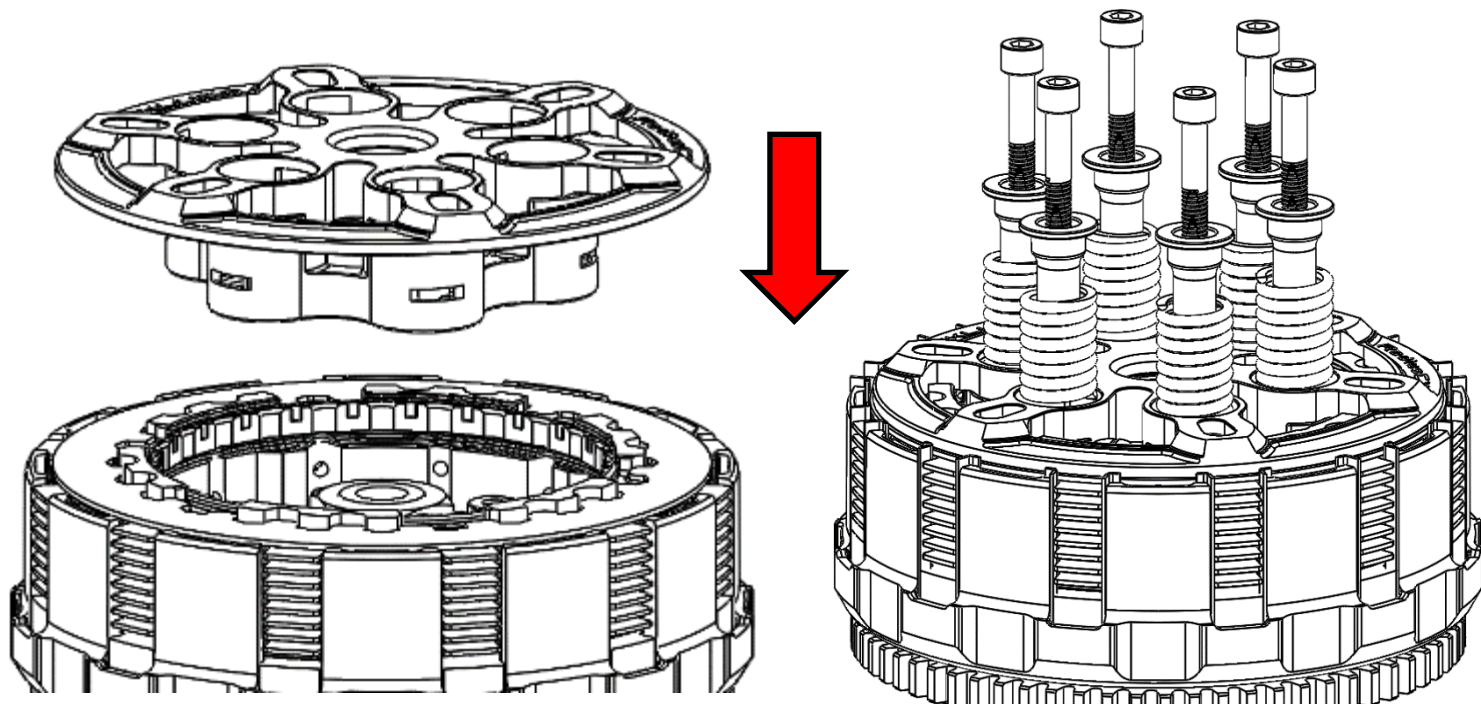

NOTICE

Heavier springs are available for purchase from Rekluse for high horse-power applications.

13. Using a torque wrench, tighten the pressure plate bolts to **9 ft-lb (12-N-m)**.
14. Adjust the clutch lever at the perch per the OE recommendation.



INSTALL THE CLUTCH COVER

1. Reinstall the OE cover gasket.
2. Place the Rekluse clutch cover onto the bike. Reinstall the OE bolts into the clutch cover. Be sure to return the bolts in the same location they were removed.

⚠ CAUTION

Failure to install the OE clutch cover bolts back in their proper location can result in damage to your motorcycle.

3. If your bike has an OE oil fill plug and/or an engine inspection plug, transfer the plugs to the new Rekluse clutch cover. Tighten the plugs.

Suzuki 450:

Install the included oil check bolt and crush washer into the oil check hole.

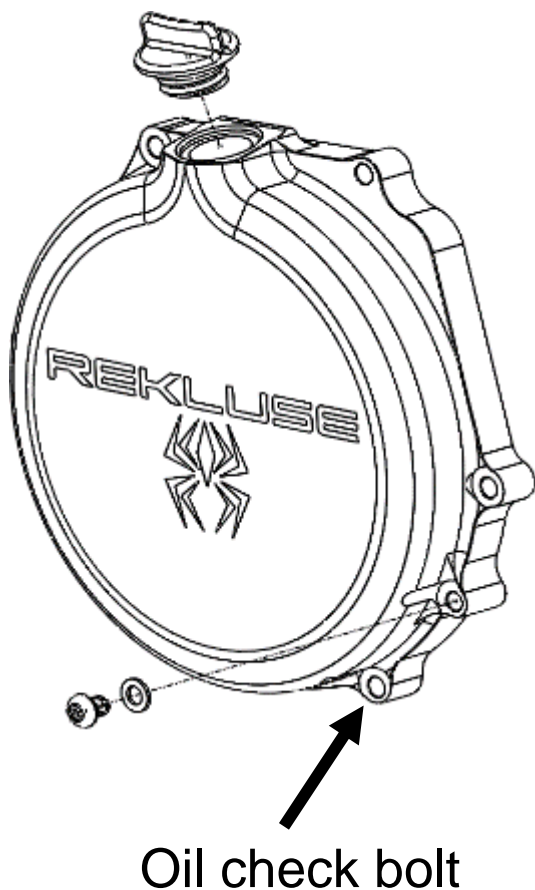

4. Finish the installation by checking Free Play Gain and breaking in the new Rekluse clutch.

CHECK FREE PLAY GAIN

It is very important that you understand how to verify the correct installed gap by checking Free Play Gain.

Setup, break-in, and rechecking the installed gap is CRUCIAL. Failure to properly maintain your installed gap can result in premature wear or failure of your clutch.

The “installed gap” is the free space in the clutch pack when the EXP disk is disengaged (collapsed). This gap allows the clutch to spin freely until the engagement RPM is reached and the EXP disk expands to close the gap and apply pressure to the pressure plate, which in turn drives the motorcycle forward.

The installed gap is what allows the auto function of the product to perform properly. Use the following steps to set the installed gap and check the Free Play Gain.

⚠ WARNING

Failure to check and verify Free Play Gain can cause failure or damage to this product. Setting the correct installed gap is critical for clutch performance.

⚠ CAUTION

Do not ride your bike without adjusting the installed gap. You will not be able to disengage the clutch until you set the installed gap.

Step 1: Learn how to check Free Play Gain

If you are familiar with checking Free Play Gain, check the Free Play Gain and skip to Step 2, “Step 2: Adjust Free Play Gain.”

If Free Play Gain is new to you, follow the instructions below to help you learn this important step. You can also view the video

entitled “How to Check Free Play Gain” on our website at www.rekluse.com/support/videos.

Free Play Gain is different from the “normal” free play (slack) you are used to with your stock clutch. With the Rekluse auto clutch, Free Play Gain is the result of the EXP disk expanding and lifting the pressure plate to engage the clutch.

Free Play Gain happens when the engine’s RPM increases from idle to above approximately 5,000 RPM and the EXP closes the installed gap. The amount of Free Play Gain you feel in the lever corresponds to the amount the pressure plate has been lifted by the EXP disk expansion.

Checking Free Play Gain allows you to externally monitor the installed gap so you can know when to make an adjustment if the installed gap is too large or too small.

The correct installed gap is verified by observing and feeling the increased free play movement in the clutch lever. This extra movement is called “Free Play Gain.”

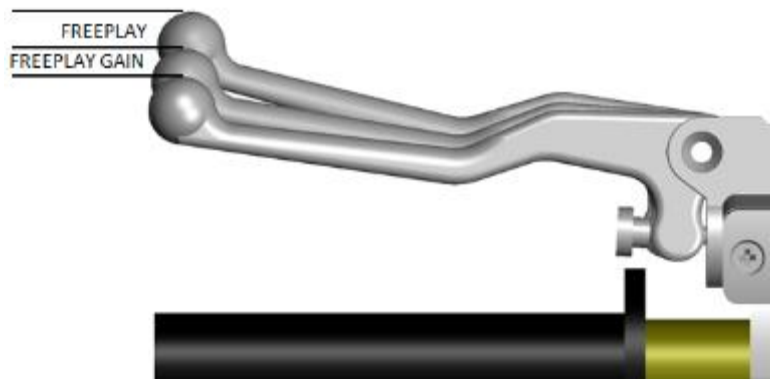
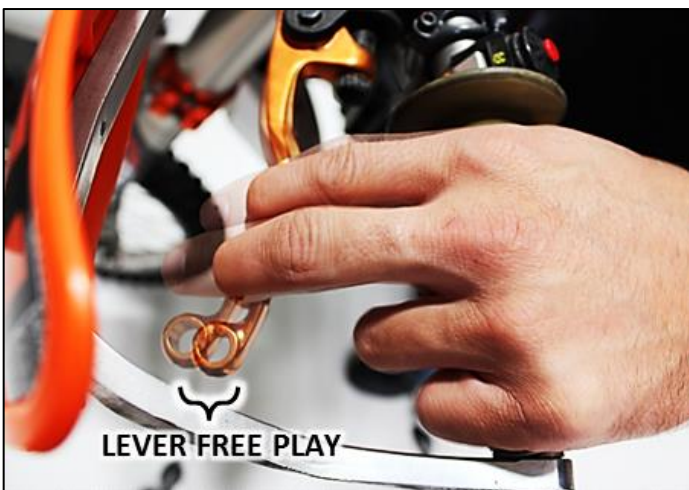

If there is too much Free Play Gain, the installed gap is too small. The bike may drag and stall because it has difficulty disengaging the clutch. It may also be difficult to shift. Too much Free Play Gain will not hurt the clutch, but it will negatively affect clutch performance.

With too little or no Free Play Gain, the installed gap is too large. This means when the EXP is fully expanded it does not lift the

pressure plate. The clutch may slip and make the bike seem like it is losing power. The bike may not move forward even though the engine RPM increases as if the clutch lever is slightly pulled. Too little Free Play Gain will cause the clutch system to burn up.

For most bikes:

- Optimal **Free Play Gain** yields **1/8” (3 mm)** of clutch lever movement, measured at the ball end of the lever.

YZ450F, YZ450FX, and WR450:

- Optimal **Free Play Gain** yields **1/4” (6 mm)** of clutch lever movement, measured at the ball end of the lever.

This measurement at the lever correlates to achieving the ideal installed gap.

Two Ways to Check for Free Play Gain

The following steps explain **2 ways** to check Free Play Gain. One way uses the rubber band Rekluse includes in the clutch kit, and one uses your hand. You can use either method to check for Free Play Gain.

Rekluse recommends that you begin with the rubber band method first to check for Free Play Gain and then learn the hand method. The rubber band will help you learn how to recognize Free Play Gain until you are comfortable with the hand method. Learning to check Free Play Gain by hand effectively and comfortably can make it easy to check Free Play Gain every time you ride.

⚠ WARNING

BEFORE YOU BEGIN, verify that the bike is in NEUTRAL before checking Free Play Gain. Failure to do so may result in the bike lurching forward, and loss of control and/or injury may result.

A Rekluse auto-clutch can make your motorcycle appear to be in neutral when in gear, even when the engine is running and clutch lever released.

Motorcycles equipped with a Rekluse auto-clutch can move suddenly and unexpectedly and cause riders to lose control. To avoid death, serious injury, and/or property damage, always sit on the motorcycle to start it.

The Rubber Band Method

Use the rubber band method for the initial set up. It can also be used before each ride until you feel comfortable checking the Free Play Gain using the hand method.

a) Before you begin, place the bike in **NEUTRAL**, start the engine and let it warm up for 2-3 minutes to idle down and warm the engine oil.

b) Stretch the included rubber band between your thumbs, then place the top end of the rubber band on the outer end of the left handlebar grip.



c) While holding the top end of the rubber band against the handlebar, stretch the band downward, then loop it through itself.



- d) Pull the band through the loop, then attach it to the outside end of the clutch lever. This will take up the initial free play (slack) and put the lever in a position to detect the Free Play Gain.



- e) While still in **NEUTRAL**, quickly rev the engine between 5,000-7,000 RPM (1/2 to 3/4 throttle), then let it return to idle. Notice the movement in the clutch lever when the engine is revved. This is your Free Play Gain.

NOTICE

It is very important the motor returns to idle before revving the engine again or Free Play Gain will not be correct.

- f) When the bike returns to idle, rest your hand across the clutch lever. Rev the engine again to 5,000-7,000 RPM so you can observe the movement while feeling for Free Play Gain with your hand.

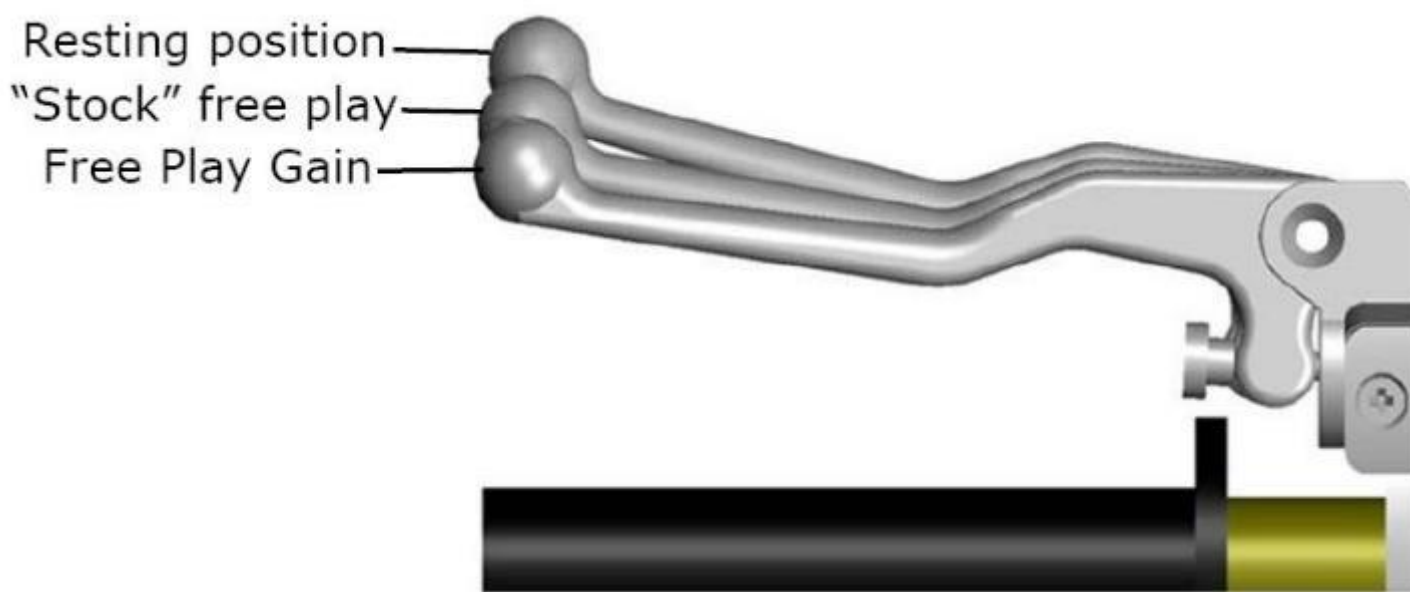

The Hand Method

Use the hand method to check Free Play Gain before the start of every ride for optimum performance and longevity of your new clutch.

- a) Before you begin, place the bike in **NEUTRAL**, start the engine and let it warm up for 2-3 minutes to idle down and warm up the engine oil.
- b) With the bike at idle, apply enough pressure to the clutch lever to take up the initial free play (slack) in the clutch lever.

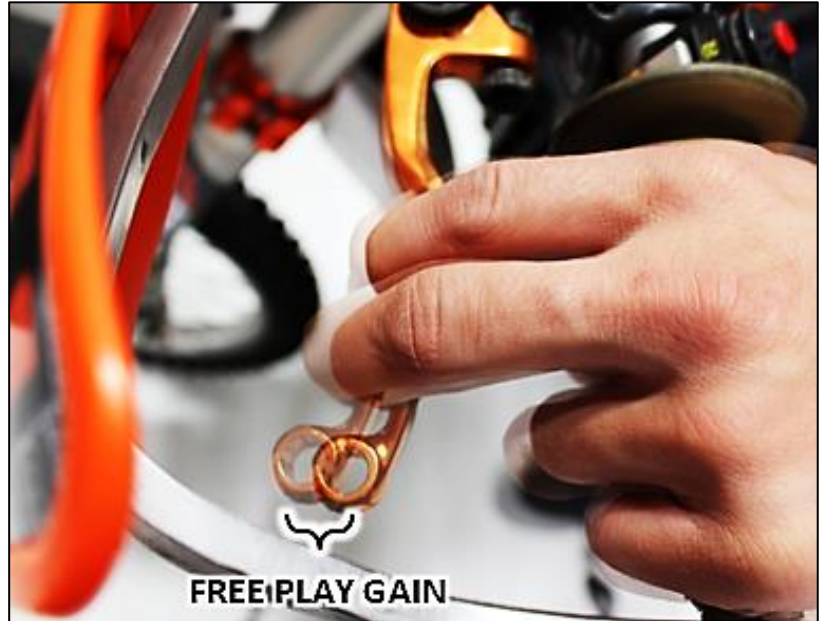

- c) While still in **NEUTRAL**, continue to apply light pressure and quickly rev the engine between 5,000-7,000 RPM (1/2 to 3/4 throttle), then let it return to idle. Notice the movement in the clutch lever when the engine is revved. This is your Free Play Gain.

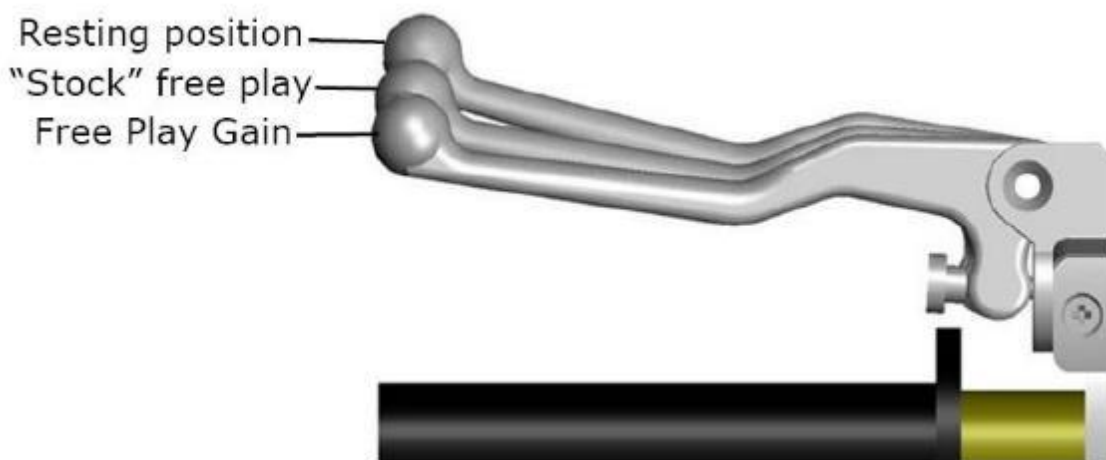

- d) When the bike returns to idle, rev the engine between 5,000-7,000 RPM a second time to verify the Free Play Gain again.

Step 2: Adjust Free Play Gain

If Free Play Gain is optimal, continue to step 3, “Step 3: Break in the new clutch.” If Free Play Gain is not optimal, the installed gap needs to be adjusted.

Use the internal adjuster ring to achieve the correct amount. The installed gap should be fine-tuned in small increments and then recheck Free Play Gain.

Refer to the table below to set the proper installed gap based on your Free Play Gain. Directions for the adjusting the gap internally are explained in section below the table.

Adjust the Installed Gap with Internal Adjuster Ring

Symptom	Reason	Solution
<ul style="list-style-type: none">• Clutch lever moves in too far (too much Free Play Gain)• Clutch has excessive drag or stalls• It is difficult to fully override the clutch with the lever	Installed gap is too small	<p>Turn the internal adjustment ring 1 circle detent counterclockwise to increase the installed gap and decrease Free Play Gain.</p> <p>Recheck Free Play Gain.</p>

<ul style="list-style-type: none"> • Clutch lever only moves slightly or does not move at all (too little Free Play Gain) • Clutch slips • Bike seems to lose power 	<p>Installed gap is too large</p>	<p>Turn the internal adjustment ring 1 circle detent clockwise to reduce the installed gap and increase Free Play Gain.</p> <p>Recheck Free Play Gain.</p>
<ul style="list-style-type: none"> • Cable lever has free play (slack) but no Free Play Gain 	<p>Installed gap is too large</p>	<p>Starting point may be incorrect. Return to the section “Set the installed gap internally” to re-find the starting point and begin with the initial adjustment.</p>

To adjust the installed gap internally:

⚠ CAUTION

If the bike is hot, wear gloves or wait until clutch cover has cooled before making the adjustments to avoid burns.

1. Remove the clutch cover according to the directions in “DISASSEMBLE CLUTCH.”
2. Lift the pressure off the adjustment ring by pulling the clutch lever toward the handlebar and securing it with a Velcro strap provided.



3. Unlock the adjuster ring by pushing the locking pin down and turning it a quarter turn to release it.

⚠ CAUTION

Keep steady pressure when locking or unlocking the locking pin. The pin is spring-loaded and can fly out suddenly if released quickly.

4. On either side of the locking pin, place the tip of a flat blade screwdriver into an adjustment notch and turn **ONE CIRCLE DETENT** clockwise or counterclockwise according to the table.
5. Lock the adjuster ring by pushing the locking pin down and turning it a quarter turn to release it.

⚠ CAUTION

Be sure to line up the locking pin with the circle detent before turning. Don't force the pin down. This can cause the pin to break. The pin should insert easily. Forcing the pin down can also tear the attached O-ring.

6. Reinstall the clutch cover according to the directions in "INSTALL THE CLUTCH COVER."
7. Release the Velcro strap and recheck Free Play Gain.
8. When Free Play Gain is optimal, continue with step 3, "Step 3: Break in the new clutch."

Step 3: Break in the new clutch

Once you install your new clutch, it is important to break it in. A series of roll-on starts are used to break in the clutch. Follow these procedures for breaking in your clutch and any time new friction disks, EXP bases, Teflon pads, or wedges are installed.



⚠ WARNING

Failure to follow the break-in procedure and oil screen inspection process could cause motor oil delivery failure, which can result in motor failure, serious injury, or death.

Break-in Procedure	Number of times
<p>Rev Cycles:</p> <ol style="list-style-type: none"> Place the bike in NEUTRAL. With your hand off the clutch lever, rev the engine 10 times, being sure to let it return to idle between each rev cycle. 	<p>① N ② ③ ④ ⑤</p> <p>10 rev cycles</p>
<ol style="list-style-type: none"> With the engine still running, pull in the clutch lever, then shift the bike into 1st gear. Slowly release the clutch lever. The bike should stay running and in place, or have a slight amount of forward creep. With the bike idling in first gear, slowly apply throttle to begin moving. Without using the clutch lever, accelerate moderately to approximately 5,000 RPM to fully lock up the clutch and come to a complete stop. Repeat 10 times. 	<p>① N ② ③ ④ ⑤</p> <p>10 roll-on starts</p>

NOTICE

If the engine wants to stall or the creep is excessive, the idle may be too high or the installed gap may be too small. Make necessary adjustments before proceeding.

<p>6. Without using the clutch lever, start in 2nd gear, then accelerate moderately to approximately 5,000 RPM and come to a complete stop. Repeat 10 times.</p>	 <p>10 roll-on starts</p>
<p>7. Place the bike in NEUTRAL and recheck Free Play Gain. Adjust the installed gap until the clutch lever is 1/8" to 1/4" (3 mm-6 mm) depending on the bike model.</p>	 <p>Recheck Free Play Gain and adjust the installed gap</p>

NOTICE

Your clutch pack will expand with heat, so final adjustment to Free Play Gain should be made when the bike is warm. Remember not to ride without sufficient Free Play Gain.

4 strokes only: It is normal for some clutch debris to be produced during break in. Following break-in, remove and inspect the OE oil filter. Clean or replace it if necessary. Remove and inspect any additional oil screens for clutch debris and clean or replace if necessary.

CAUTION

Do not perform 3rd gear starts with this product. Starting in 3rd gear will burn up the clutch and decrease the performance of this product in a short amount of time.

LEVER SAFETY STRAPS

Your kit includes a Velcro strap to be used to secure either the clutch lever or the front brake lever when the bike is parked.

This strap is intended to reduce the risk of injury or damage that may occur from the bike rolling or launching unexpectedly with or without a rider. Use the lever safety strap every time you park or leave the bike. **Refer to the Safety Information sheet for more information.**

1. Pull the lever tight against the handlebar.
2. Wrap the Velcro safety strap around the lever and handlebar, pull it tight, then fasten it.

Clutch lever strap: Use to prevent unwanted launching.

Brake lever strap: Use as a parking brake.



MAINTENANCE

To keep your clutch performing at its best, perform regular maintenance on your bike and clutch.

- Keep up with regular oil changes according to the bike manufacturer's recommendations. Clutch performance and longevity depend on oil quality.
- Oil recommendations can also be viewed under Tech Tips on our website at www.rekluse.com/support/videos/atv-mc-support-videos.

- Inspect all of your clutch parts for signs of wear or excessive heat, and replace components as necessary. This includes your basket sleeves and dampers. Clutch wear is dependent on the riders use. See the Setup Sheet at the back of the manual for additional information.

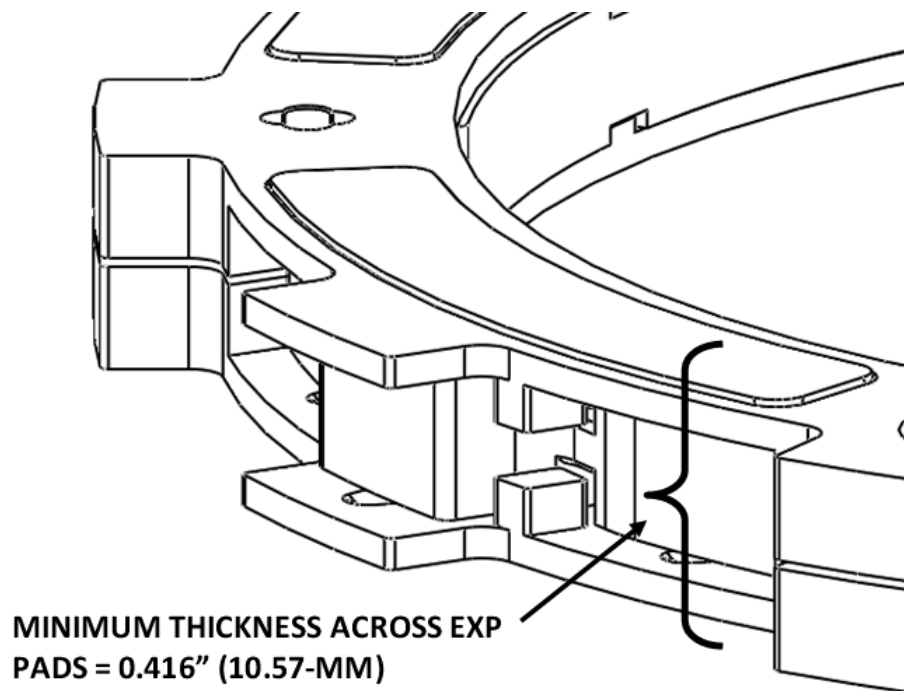

Maintenance Protocol	Maintenance Intervals
Check and verify Free Play Gain	Every ride
Inspect all clutch parts for excessive wear or heat. Replace as needed.	Refer to OE service manual
Change oil, inspect and clean oil screen	Refer to OE service manual

- Measuring the clutch pack and/or the EXP disk can help determine if the components need replacing. See the Setup Sheet at the back of the manual for the specific clutch pack measurements.
- Maintain adequate Free Play Gain. Check before every ride and adjust if necessary.
- Repeat the break-in procedure anytime you replace the EXP bases, Teflon pads, EXP wedges, or frictions disks. Always soak friction disks or EXP bases in new oil for at least 5 minutes before installing.

- Replace friction disks if they measure below specifications listed on the Setup Sheet at the back of the manual or if the disks are glazed and/or burnt.
- Replace the drive plates if they show signs of excessive heat.

Disk inspection examples

When inspecting the clutch pack, the following pictures can be used as a reference. **These are best viewed in color by viewing this install document from www.rekluse.com/support.**

Drive Plates – If the clutch pack is getting high amounts of heat, purple, blue, or black color can be seen on the drive plate teeth. See pictures below. Not all drive plates look the same and may look different than pictured.



Normal Heat

High Heat
(Blue)

Excessive Heat
(Black)

Friction Disks – Due to the dark color of the friction material, the friction disks will appear almost black as soon as they are put in oil. During inspection, look for glazing of the friction material. Glazing will appear shiny and feel like glass, even after oil is cleaned from the friction disk. Not all friction disks look the same and may look different than pictured.



Normal Friction



Glazed Friction

TROUBLESHOOTING

Performance issues

If you find yourself constantly adjusting Free Play Gain or adjusting for drag, the clutch disks might be worn. Excessive heat or clutch slip can cause premature clutch failure as well. Once extreme temperatures are reached, irreversible damage will occur.

- Inspect all of your clutch parts for signs of wear or excessive heat, and replace components as necessary. Clutch wear is dependent on the riders use.
- Measuring the clutch pack and/or the EXP disk can help determine if the components need replacing. See the attached Setup Sheet at the back of the manual for the specific clutch pack measurements.

Clutch noise

Although it is harmless, some bike models may have noise coming from the clutch at low RPM as it engages. Clutch noise is caused by the clutch components vibrating as the clutch engages

and can become more audible as the clutch gets hot. Adjusting the installed gap will NOT affect clutch squeal or chatter.

For bike models that have noise, here are some recommendations to reduce or eliminate it:

- For optimal clutch performance Rekluse recommends using fresh, clean oil that **meets JASO-MA** oil rating requirements. Dirty or old oil can make the clutch more likely to squeal or chatter.
- Some bikes are more prone to clutch squeal and chatter than others. You can convert to from internal to external adjustment to reduce noise if desired.

Locking pin O-ring

The RadiusCX comes with an O-ring installed on the locking pin. It acts as a damper between the clutch and the adjustment ring to prevent clutch noise. A missing O-ring will not affect how the clutch functions or damage the internal adjustment ring. An extra O-ring comes in the kit in case you need to replace it.

EXP TUNING OPTIONS

Adjusting the engine idle speed to match your engagement setting is important and greatly affects the overall feel of how the EXP disk engages.

You can tune the engagement RPM of the EXP disk by changing the spring configuration. The EXP disk comes set with the recommended “**Medium**” setting from Rekluse. **For other EXP tuning options, see the Setup sheet at the back of the Installation Manual.**

To prevent freewheeling and maximize engine braking, set the idle so there is a slight amount of drag while the bike is idling in gear and warmed up. The idle should not be so high as to move the bike forward in gear with the throttle closed.

With correct Free Play Gain and the bike in gear, the bike should move forward under slight opening of the throttle. If not, one of the following symptoms is likely:

- **HIGH IDLE:** The bike moves forward with the throttle fully closed. Solution: reduce idle RPM.
- **LOW IDLE:** The bike moves forward after engine RPM becomes noticeably higher than idle RPM. Solution: increase idle RPM.

Changing the EXP springs

Use the following steps to change the EXP spring configuration. It is **NOT necessary** to disassemble the EXP halves to change springs!

1. Using a flat-blade screwdriver, push the $\frac{1}{4}$ turn pin in far enough to clear the opposite side of the EXP to unlock the pin.
2. With the pin still pushed past the base, turn 90° to remove the pin and spring.

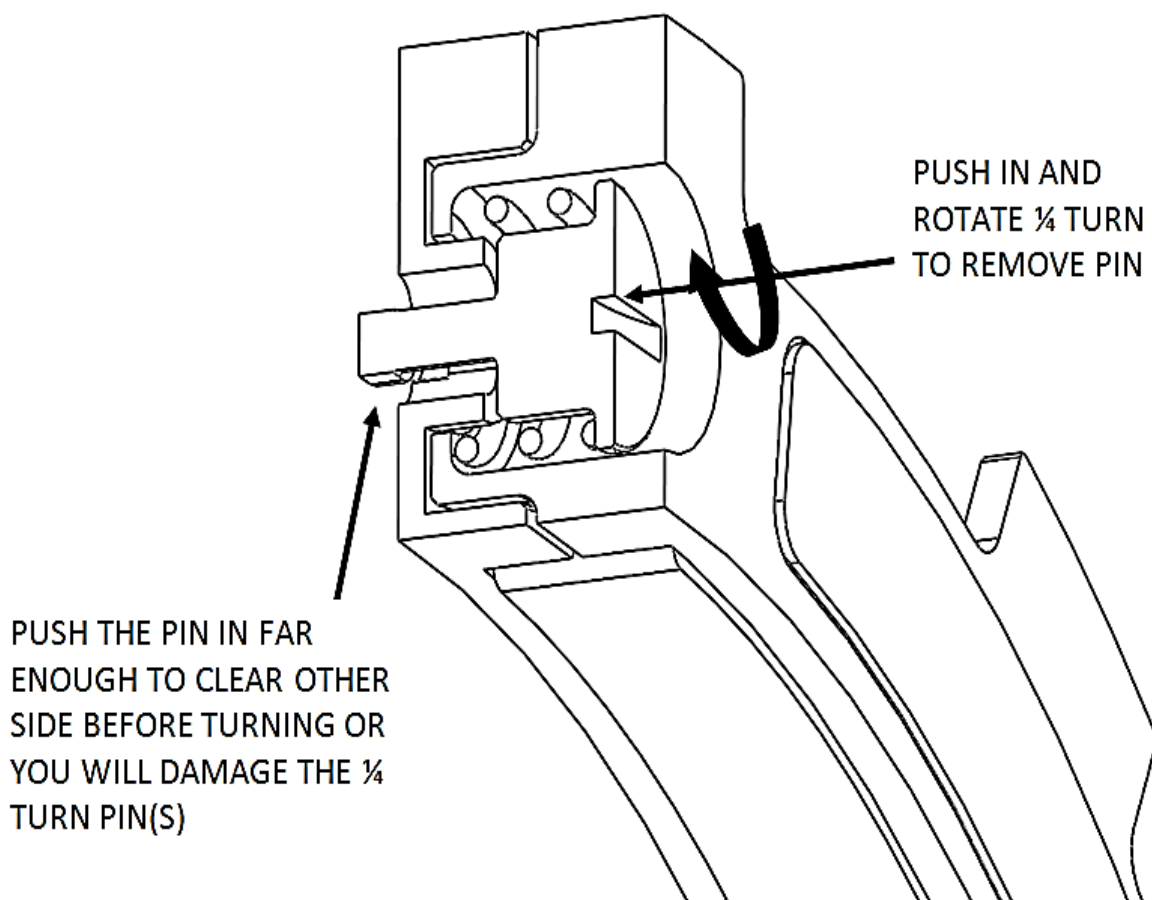

3. Remove the remaining 2 pins and springs from the same side of the EXP base.
4. Drop a new spring into the spring slot on the base, then add the $\frac{1}{4}$ turn pin.

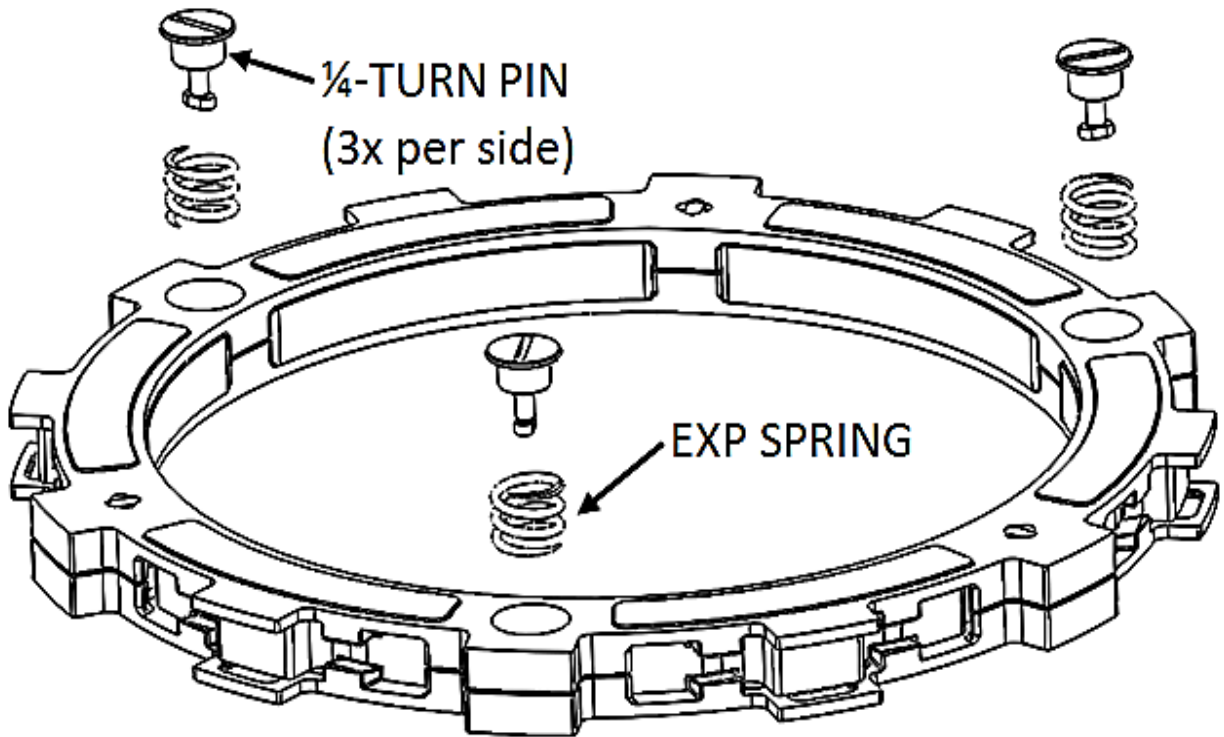

NOTICE

To maintain even pressure, when using two different color spring sets, install one set of 3 on one side of the EXP and the remaining set of 3 on the other side.

5. Push the turn pin in far enough to clear the base, then turn 90° and release the pin. The pin should sit almost flush with the EXP base.
6. Flip the EXP friction disk over, and repeat on the other side depending on engagement preference.
7. If you need to disassemble the EXP disk, you can watch the video on our website under Tech Tips at www.rekluse.com/support/videos/atv-mc-support-videos.

⚠ CAUTION

If you disassemble the EXP, the Teflon pads may fall out or be stuck to the ramp surfaces of the EXP bases. Take care to ensure all pads are correctly placed into wedge pockets using gentle pressure to avoid damage to the pad surfaces before reassembling the EXP. Properly seated pads will be secured in place once the EXP is reassembled. Operating the clutch without the pads in place will cause part damage or failure.

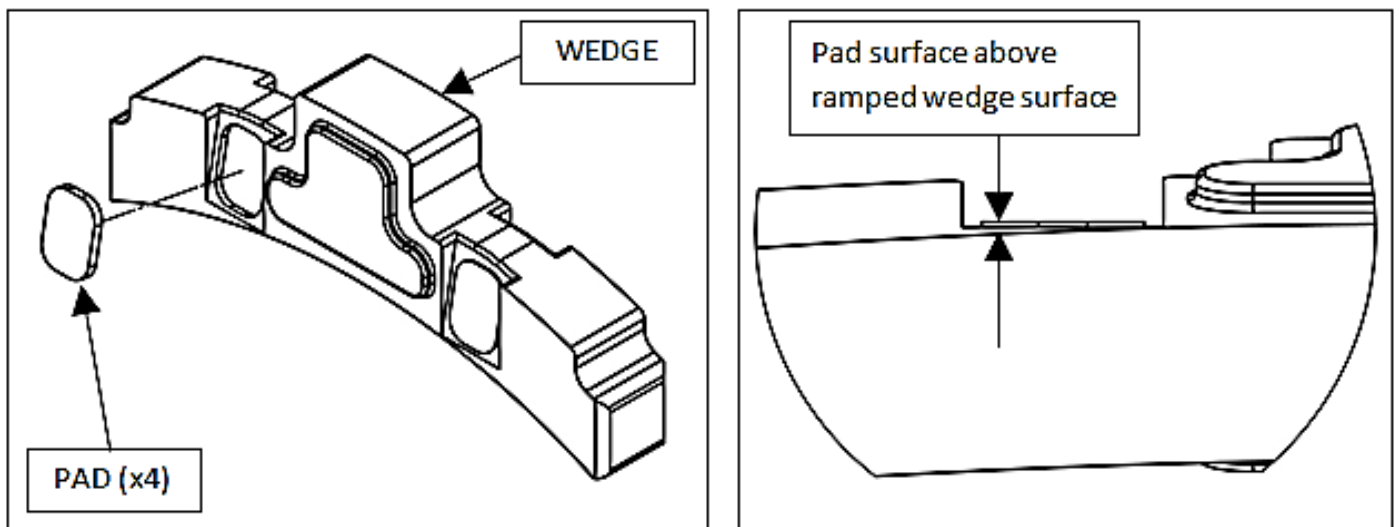

BUMP-STARTING: Internally Adjusted

FOR INTERNALLY ADJUSTED CLUTCHES ONLY. See the “BUMP-STARTING: External” section in Appendix A for instructions on how to bump start with the external adjustment method.

1. Remove the clutch cover.
2. Pull the clutch lever to lift the pressure plate, and secure the lever to the handlebar using the Velcro strap provided.
3. Unlock the red locking pin, and turn the adjuster ring clockwise until it bottoms out in the center hub.
4. Lock the locking pin to secure the ring in place.
5. Release the clutch lever, and use the perch adjuster to remove cable tension until you have lever free play (slack).

6. Install the clutch cover and bump-start the bike. The clutch will function like a manual clutch at this point, but the clutch will not be fully over-rideable at high RPM.

CAUTION

It is not recommended to ride any further than necessary with the clutch's installed gap collapsed.

7. When able, reset the installed gap using either the internal or external adjustment method before riding again.

CLUTCH LEVER OPTIMIZATION

If your bike model is not equipped with a perch adjuster bolt (as seen below), you may purchase, as an option, a Rekluse Adjustable Reach Lever.

Adding this accessory maximizes your clutch lever feel during operation. If you opt to continue installation without the Rekluse Adjustable Reach Lever and your bike is not equipped with an OE perch adjuster bolt, continue with the sections on “Set the installed gap internally,” or Appendix A “Set the installed gap externally.”

Optimization with OE Perch Adjuster

Kits for Yamaha YZ450F and YZ250F include a new perch adjuster bolt. Replace your OE perch adjuster bolt with the one included in your kit. These bolts will not be used on the YZ450FX and YZ250FX.

Set the clutch lever to the desired reach point while maintaining clutch lever slack.

- Turning your adjuster bolt farther in will bring the lever closer to the bar and allow for a closer reach point.

- Backing your adjuster bolt farther out will push the lever farther from the bar and allow for a further reach point.

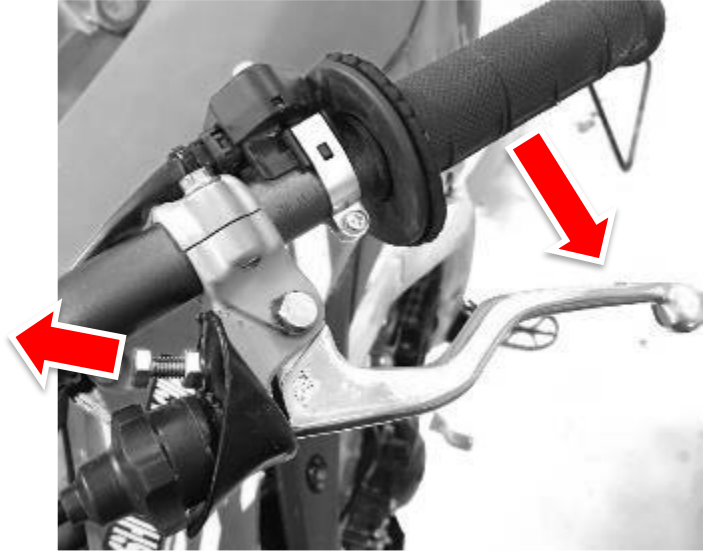
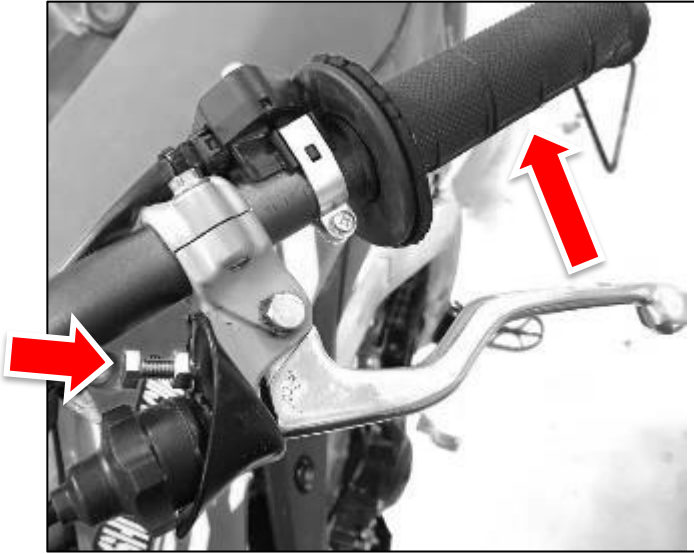

Optimization with Rekluse Adjustable Reach Lever

Set the clutch lever to the desired reach point while maintaining clutch lever slack.

- Turning your adjuster bolt farther in will push the lever farther from the bar and allow for a further reach point.
- Backing your adjuster bolt farther out will bring the lever closer to the bar and allow for a closer reach point.

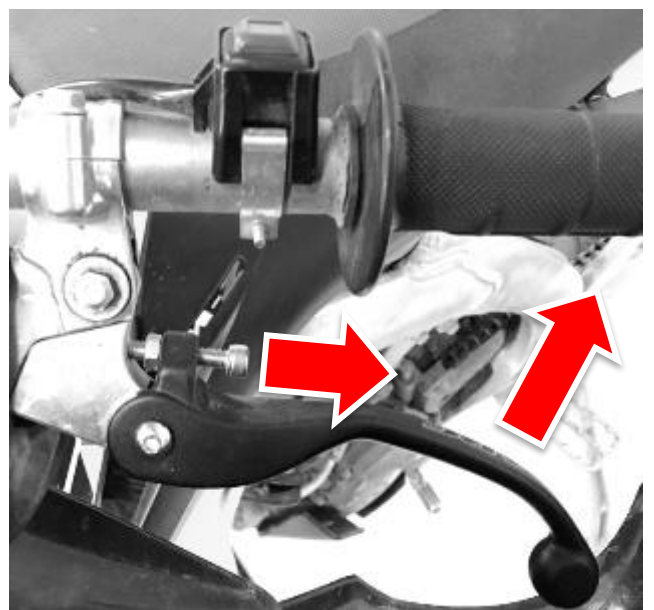
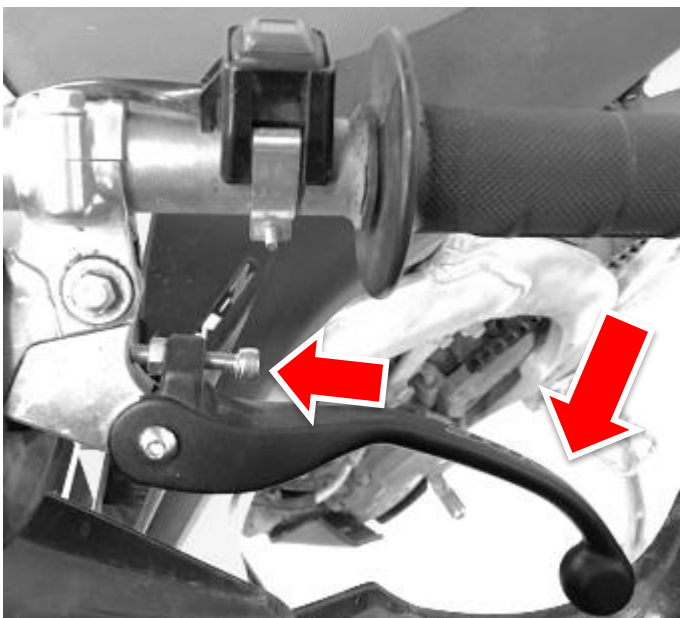

APPENDIX A

Set the installed gap externally

The adjustment ring comes in the proper position for external adjustment. No adjustment is needed.

If you are switching from internal adjustment to external adjustment, turn the ring clockwise until it bottoms out in the hub.

1. Reinstall the OE throw-out assembly (throw-out, bearing, and washer). If the washer is missing, check to see if it is stuck to the underside of the pressure plate.

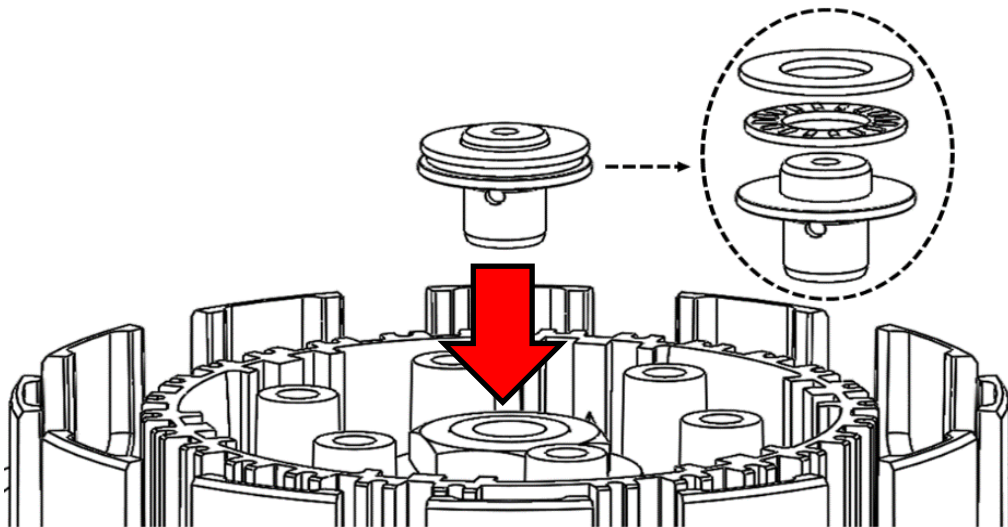

CRF250X owners:

Your kit includes a throw-out assembly that must be used in place of your OE throw-out. Install your Rekluse throw-out assembly now.

YZ125 owners:

Your kit includes an additional throw-out spacing washer to achieve correct spacing. Install the Rekluse spacing washer on top of the OE throw-out and washer.

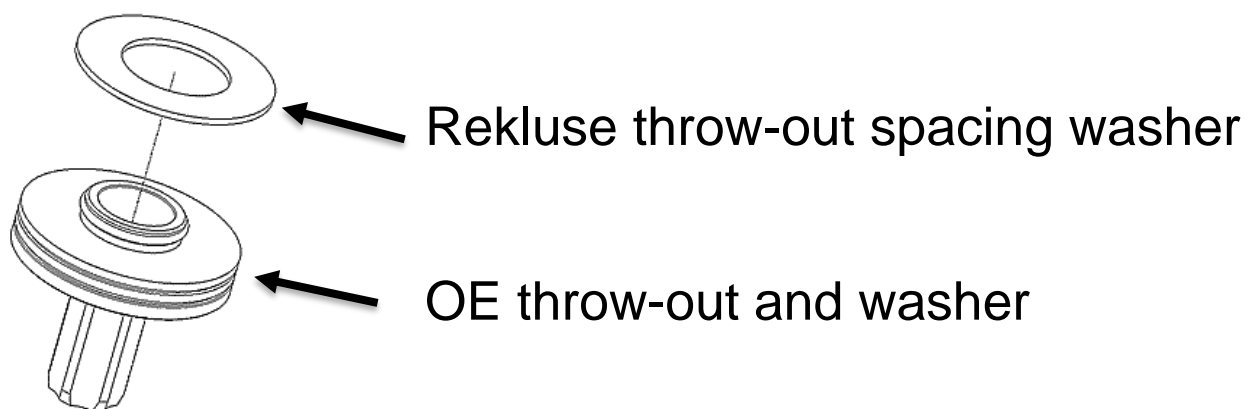

Rekluse throw-out spacing washer

OE throw-out and washer

⚠ CAUTION

Suzuki RM-Z450 Models: The needle bearing only has the bearings on one side. Make sure that the bearing side is facing the throw-out and the flat side is facing the pressure plate.

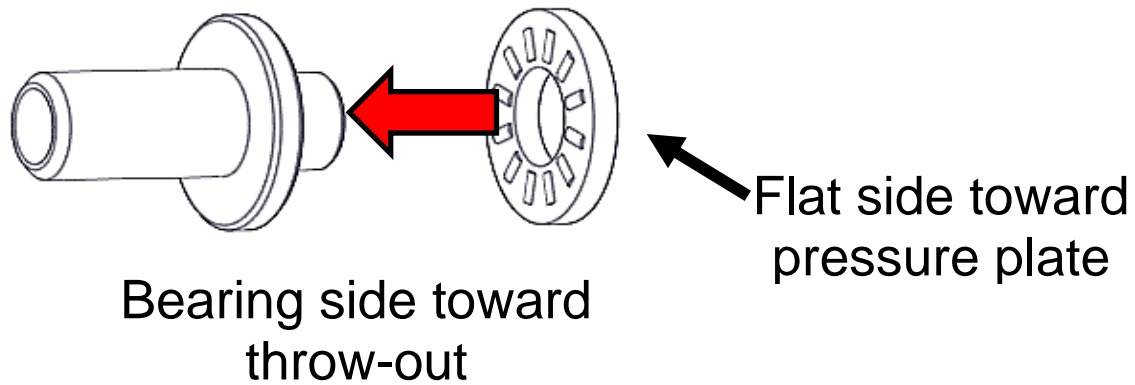

2. Reinstall the pressure plate, followed by the pressure plate springs, screw sleeves, and bolts.

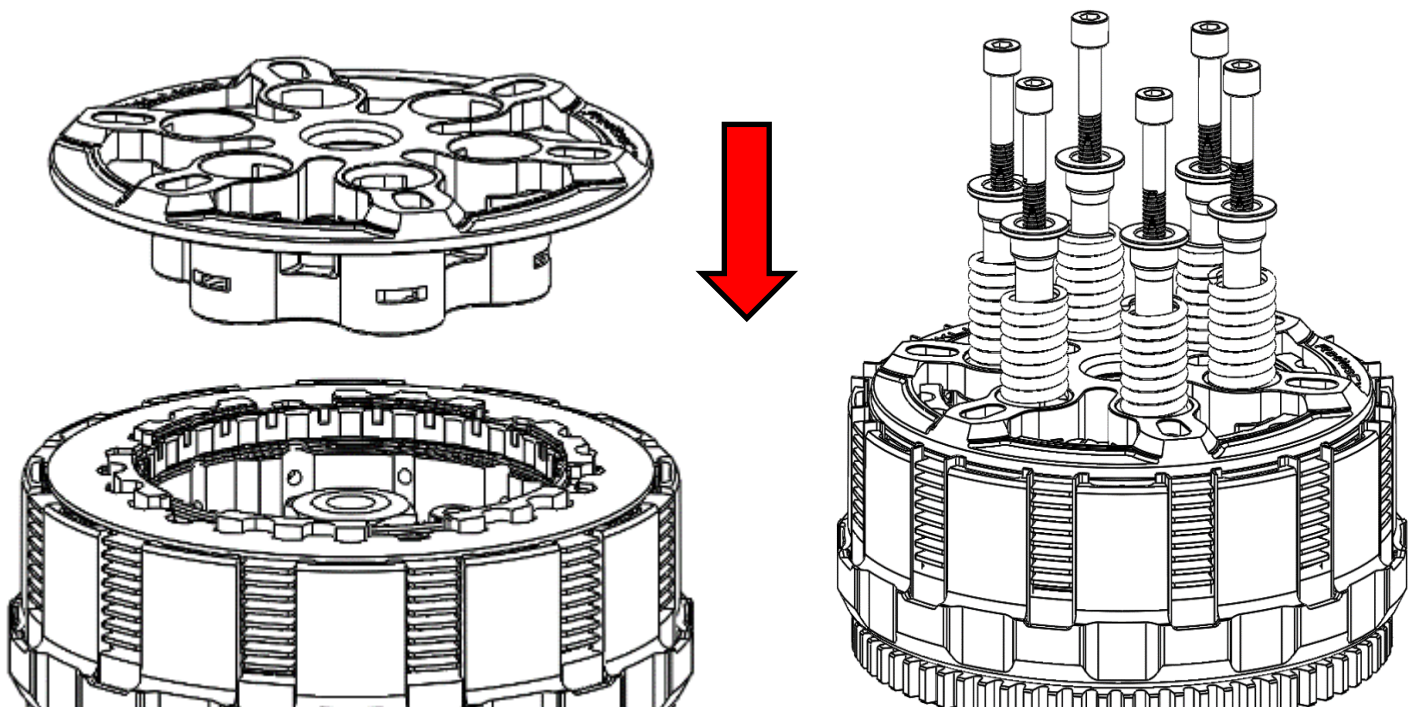

⚠ CAUTION

Do not reuse the OE springs or bolts. They will cause interference with the clutch cover!

NOTICE

Heavier springs are available for purchase from Rekluse for high horse-power applications.

3. Using a torque wrench, tighten the pressure plate bolts to **9 ft-lb (12-N-m)**.
4. Reinstall the OE cover gasket.
5. Place the Rekluse clutch cover onto the bike. Reinstall the OE bolts into the clutch cover. Be sure to return the bolts in the same location they were removed.

⚠ CAUTION

Failure to install the OE clutch cover bolts back in their proper location can result in damage to your motorcycle.

6. If your bike has an OE oil fill plug and/or an engine inspection plug, transfer the plugs to the new Rekluse clutch cover.

Suzuki 450:

Install the included oil check bolt and crush washer into the oil check hole.

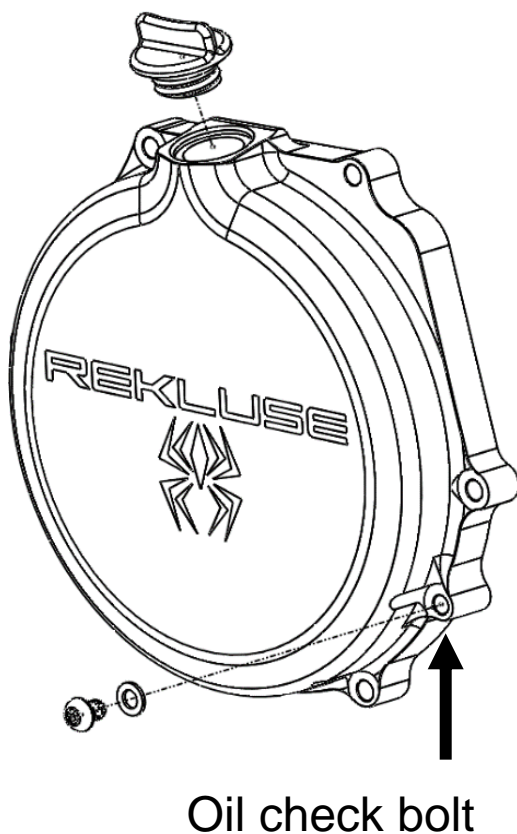

7. Stand the bike upright.

8. Use a wrench to loosen the jam nut and completely collapse the in-line cable adjuster allowing for plenty of clutch cable and lever slack.

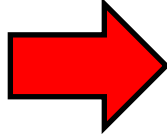

9. At the in-line cable adjuster, tighten the clutch cable tension to the point where there is no lever freeplay (the clutch lever is tight against its perch). At this point, there should be no cable slack.

*CLUTCH LEVER TIGHT
AGAINST PERCH
(ADJUST SLACK INTO CABLE)*

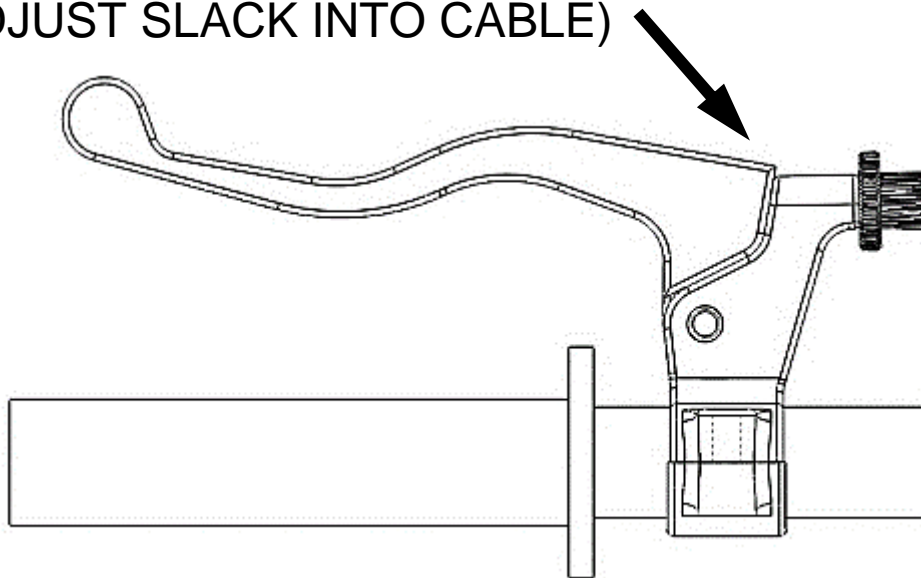

10. Expand the in-line cable adjuster housing 5 turns to lift pressure plate. This is not your final setting. It is your **starting point** for setting the installed gap. This will vary by bike.

11. To set the final install gap, check Free Play Gain. Refer to the section “CHECK FREE PLAY GAIN” for the directions.
12. When Free Play Gain is optimal, continue to the section, “Step 3: Break in the new clutch.”

If Free Play Gain is not optimal, the installed gap needs to be adjusted.

Adjust the installed gap by adjusting the cable at the clutch lever perch or in-line cable to achieve the correct amount. The installed gap should be fine-tuned in small increments and then recheck Free Play Gain.

Refer to the table below to set the proper installed gap based on your Free Play Gain.

Adjust Installed Gap Externally at the Perch

Symptom	Reason	Solution
<ul style="list-style-type: none"> • Clutch lever moves in too far (too much Free Play Gain) • Clutch has excessive drag or stalls • It is difficult to fully override the clutch with the lever 	<p>Installed gap is too small</p>	<p>Tighten the cable; increase the length of the in-line cable adjuster housing and/or the lever perch adjuster (extend the adjusters) until the correct amount of Free Play Gain is achieved.</p> <p>Recheck Free Play Gain.</p>

<ul style="list-style-type: none"> • Clutch lever only moves slightly or does not move at all (too little Free Play Gain) • Clutch slips • Bike seems to lose power 	<p>Installed gap is too large</p>	<p>Reduce the length of the cable housing (collapse the adjusters) until the correct amount of freeplay gain is achieved.</p> <p>Recheck Free Play Gain.</p>
--	-----------------------------------	--

BUMP-STARTING: Externally Adjusted

FOR EXTERNALLY-ADJUSTED CLUTCHES ONLY. See the “BUMP-STARTING: Internally Adjusted” section for instructions on how to bump start with the internal adjustment method.

1. Use the perch adjuster or in-line cable adjuster to remove cable tension until you have lever free play (slack).
2. Bump-start the bike. The clutch will function like a manual clutch at this point, but the clutch will not be fully over-rideable at high RPM.

⚠ CAUTION

It is not recommended to ride any further than necessary with the clutch's installed gap collapsed.

3. Once the vehicle is running, readjust the cable tension to properly set the installed gap using Free Play Gain.

NEED ADDITIONAL HELP?

Website

www.rekluse.com/support

Frequently asked questions

www.rekluse.com/faq

Support Videos

www.rekluse.com/support/videos

Phone

(208) 426-0659

Technical Support

Contact Technical Support for questions related to product installation, tuning, and performance.

Technical Support hours:

Monday thru Friday: 8:00 a.m. - 5:00 p.m.

Mountain Time zone

Email: tech@rekluse.com

Customer Service

Contact Customer Service for additional product information, orders, and returns.

Customer Service hours:

Monday thru Friday: 8:00 a.m. - 5:00 p.m.

Mountain Time zone

Email: customerservice@rekluse.com



SETUP SHEET 198-7901101

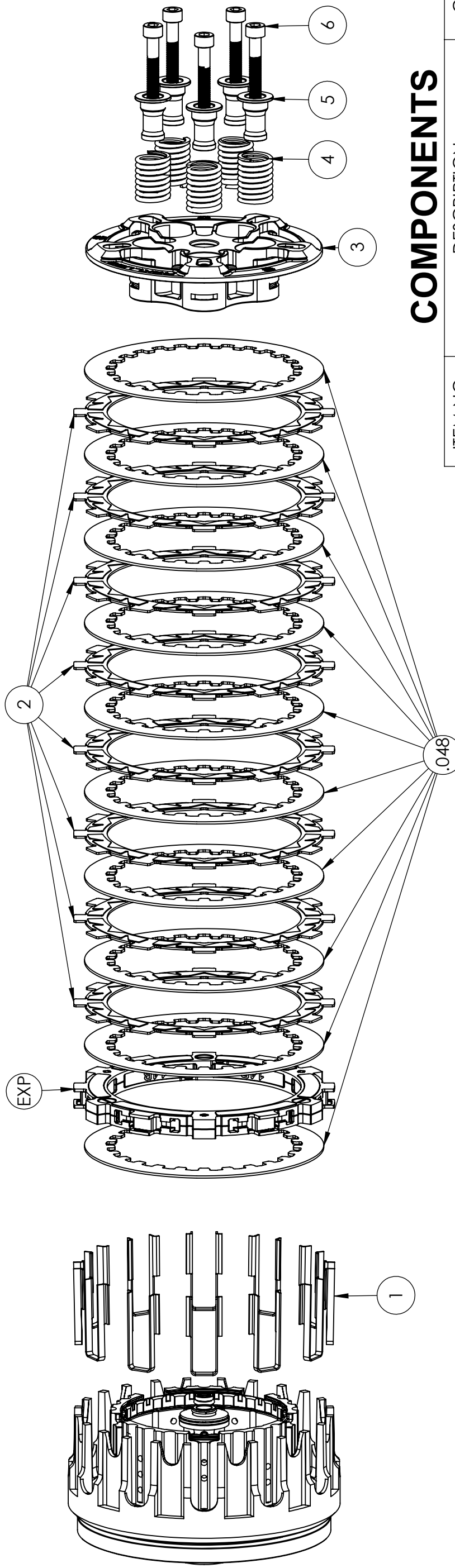

TUNING OPTIONS

ENGAGEMENT RPM	EXP SPRINGS
LOW	3 Steel & 3 Silver
MEDIUM *	6 Silver
HIGH	3 Silver & 3 Red

* MEDIUM SETTING IS PREINSTALLED IN THE EXP DISC

CLUTCH PACK THICKNESS

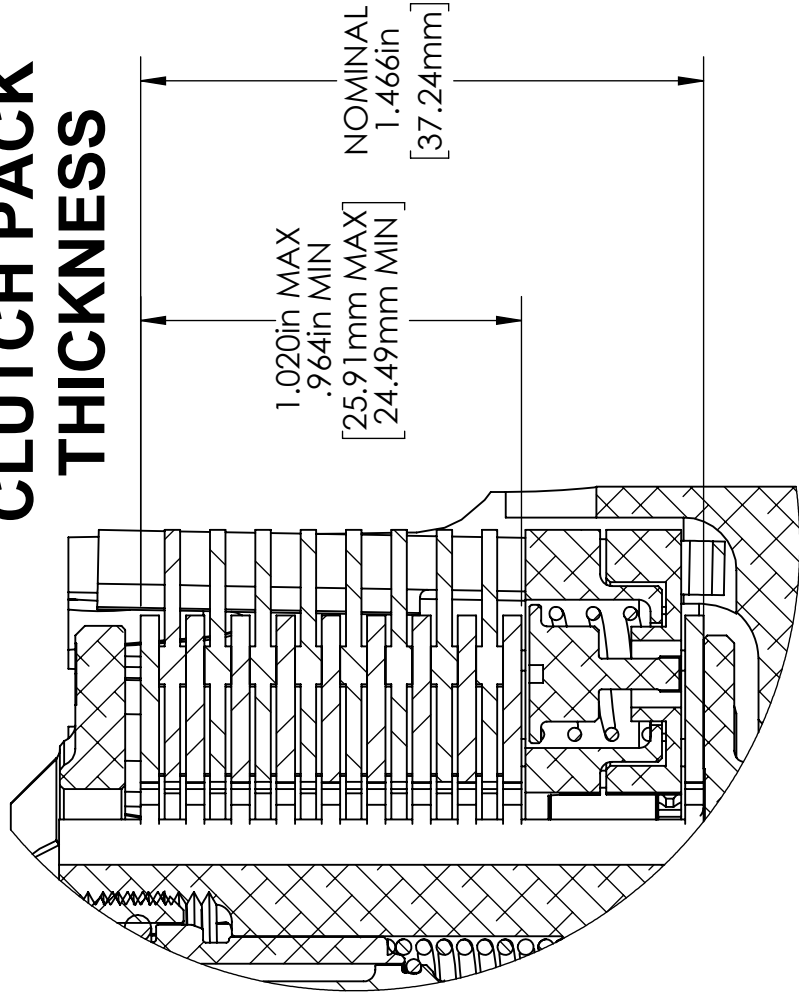

COMPONENTS

ITEM NO.	DESCRIPTION	QTY.
.048	DRIVE PLATE .048" (1.2mm)	10
1	BASKET SLEEVE	12
2	TORQ DRIVE FRICTION	8
3	PRESSURE PLATE	1
4	PRESSURE PLATE SPRING	5
5	SCREW SLEEVE	5
6	SPRING BOLT	5
EXP	EXP DISC	1

SERVICE LIMITS

COMPONENT	STANDARD	SERVICE LIMIT
TORQDRIVE FRICTION	.068-.072in 1.73-1.83mm	.065in 1.65mm
EXP	.426-.446in 10.8-11.3mm	.416in 10.6mm