



INSTALLATION & USER'S GUIDE

Upgrade kit
YXZ 1000 Auto Clutch

Doc ID: 191-6107002A
Revision: 040919

©2017 Rekluse Motor Sports
Rekluse Motor Sports, Inc.
customerservice@rekluse.com

Table of Contents

OVERVIEW	3
INSTALLATION TIPS	3
TOOLS.....	4
INCLUDED PARTS	5
DISASSEMBLE CLUTCH.....	6
INSTALL THE PRESSURE PLATE.....	7
SET THE INSTALLED GAP	9
MEASURE THE INSTALLED GAP	10
CLUTCH WARNING LABELS	12
CHECK FOR FREE PLAY GAIN	12
BREAK-IN THE CLUTCH.....	14
SHIFTING AND OPERATION	16
PARKING.....	17
ABOUT FREE-WHEELING	18
MAINTENANCE.....	19
TROUBLESHOOTING	20
Clutch noise and drag	21
BUMP-STARTING INSTRUCTIONS.....	22
NEED ADDITIONAL HELP?.....	23

OVERVIEW

This kit replaces some of the OE (Original Equipment) or “stock” clutch parts and reuses others. The following is a summary of what is replaced:

- The OE bolts, spring retainer, and Belleville spring are replaced with high quality Rekluse cap screws, springs, and pressure plate.
- The previously used Rekluse pressure plate is replaced with the newer Rekluse pressure plate



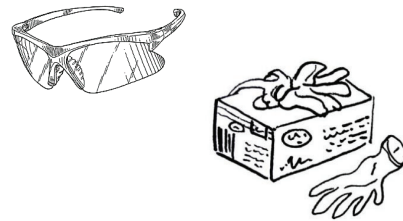



INSTALLATION TIPS

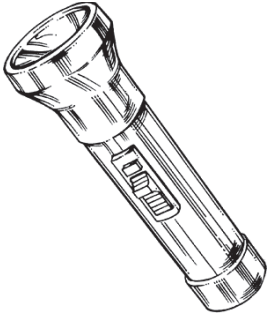

- Read the separate included Safety Information document before operating the vehicle with the product installed.
- Read this entire document before performing any steps.
- If you install this product for a customer or another person, instruct them to read the **Safety Information** document and the **Installation and User Guide** before operating the vehicle with the product.
- Protect eyes and skin – wear safety glasses and work gloves.
- Install the included safety warning labels as directed in this document so any potential vehicle operator is aware of the installation of this product.
- Use the torque values listed in the instructions. Otherwise, use the torque specifications found in your OE service manual.
- Do not leave the vehicle idling in gear while in operation. If this is done, clutch damage can result and/or the control unit will activate the warning light associated with code 42.
- For optimal clutch performance Rekluse recommends using fresh, clean oil that **meets JASO-MA** oil rating requirements.

Rekluse offers Factory Formulated Oil™ developed specifically for Rekluse products. Rekluse Factory Formulated Oil is a perfect complement to any OEM or aftermarket wet clutch. Visit www.rekluse.com to learn more.

TOOLS

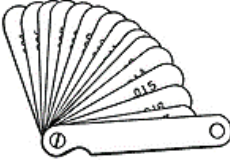
			
Flashlight	Magnet Stick (X2)	Metric Wrench Set	Torque Wrench
			
Pick	4 mm Hex key	Metric Socket Set	Feeler gauges

INCLUDED PARTS

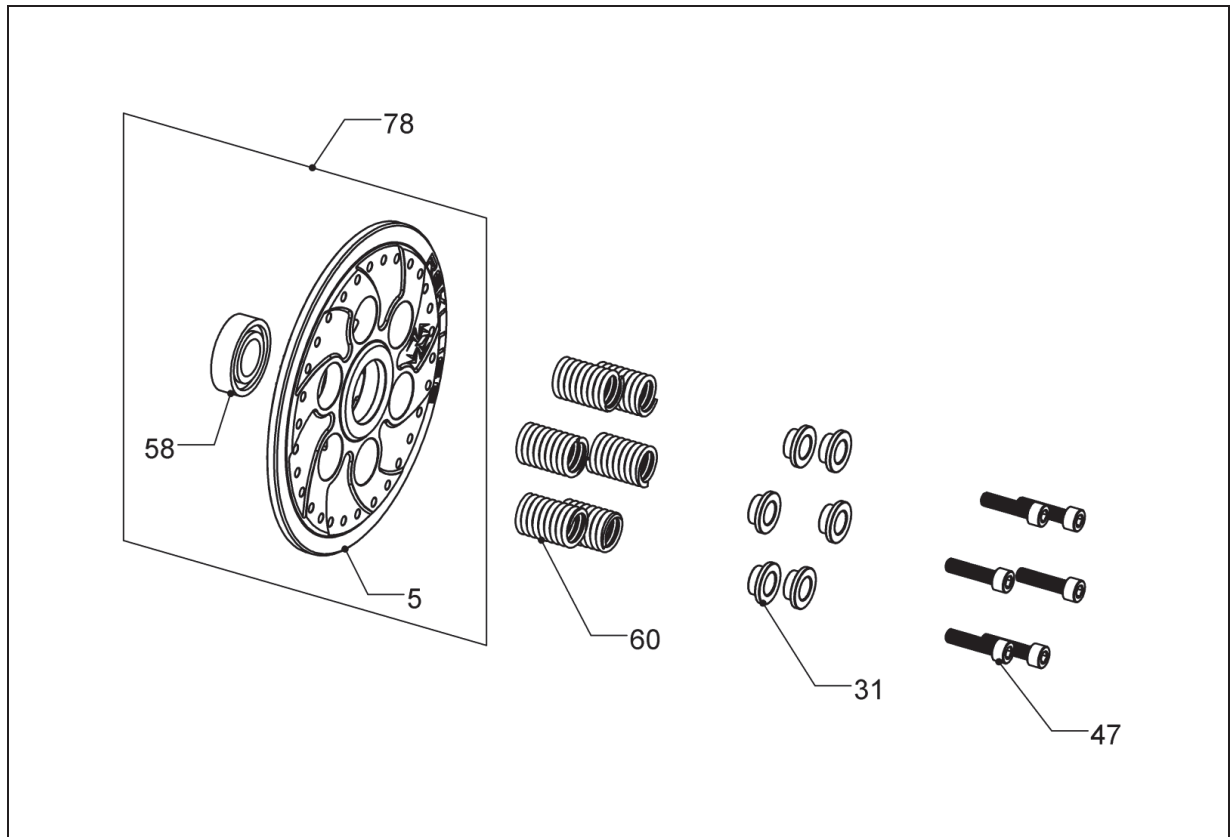

Item	Description	Qty.
78	Pressure plate assembly	1
58	Ball bearing	1
5	Pressure plate	1
60	Pressure plate springs	6
31	Screw sleeves	6
47	Socket Head cap screw	6
Not shown	Clutch cover gasket	1

Visit www.rekluse.com/support for a full parts fiche illustration and part numbers.

DISASSEMBLE CLUTCH

1. Remove the driver seat, passenger seat, and center console body panels to access the clutch cover.
2. Remove the clutch cover bolts and clutch cover. Refer to vehicle service manual for instructions.
 - It is not necessary to drain the oil however it is recommended to change the oil after clutch break-in.

Note: *The bolts along the bottom of the clutch cover also have copper crush washers. Be sure to reinstall the crush washers with the bolts in the proper locations.*

3. Remove the following OE parts from the clutch basket.
 - Bolts
 - Spring retainer
 - Belleville spring
 - Spring seat
 - Pressure plate
 - Pressure plate liner (This will be reused)

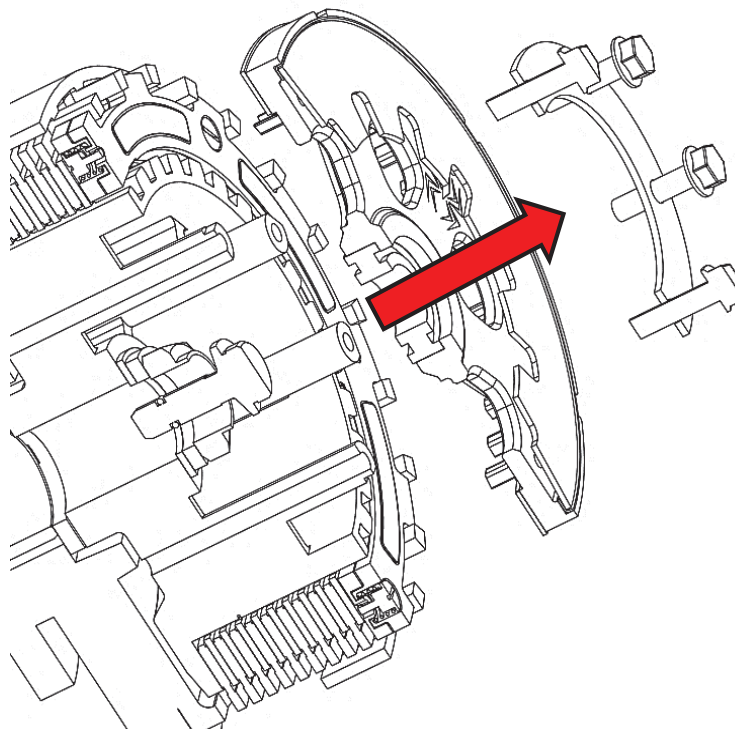

INSTALL THE PRESSURE PLATE

1. If not removed previously, remove the lining plate from older pressure plate.
2. Turn the new Rekluse pressure plate over. Prepare the pressure plate by placing a thin layer of oil between reused lining plate and the new pressure plate. *This will help hold the lining plate in place while installing the pressure plate over the clutch pack.*

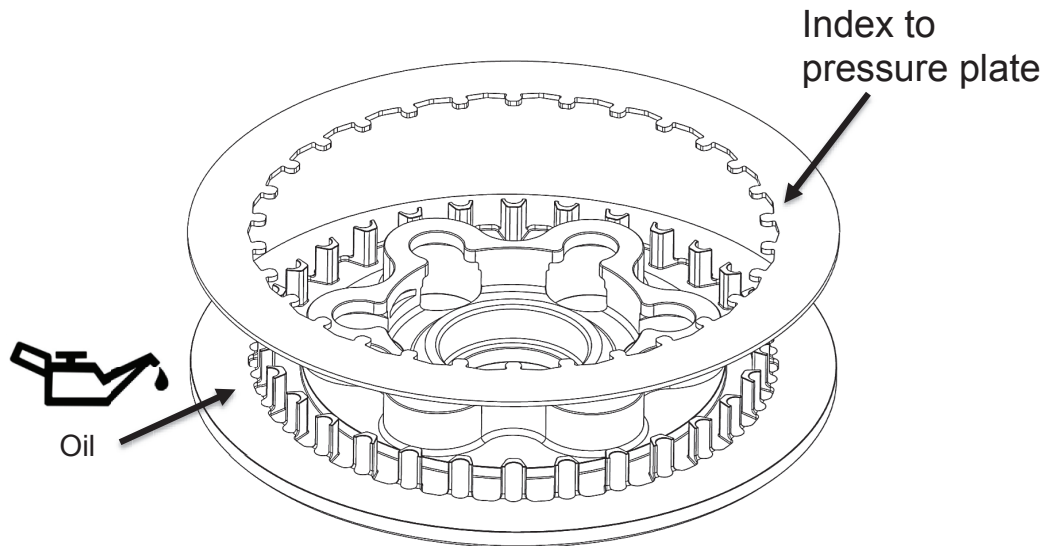

3. Index the lining plate with the teeth on the pressure plate, then install it onto the new pressure plate. *The lining plate will sit flat against the pressure plate.*
4. With the lining plate installed, turn the assembled pressure plate back over, and install it onto the clutch.
5. Install the Rekluse pressure plate springs, screw sleeves and cap screws, then torque the cap screws to 8 N-m as specified in the Yamaha service manual.

⚠ CAUTION

Do not reuse the OE spring or bolts. They are not compatible with the Rekluse core parts.

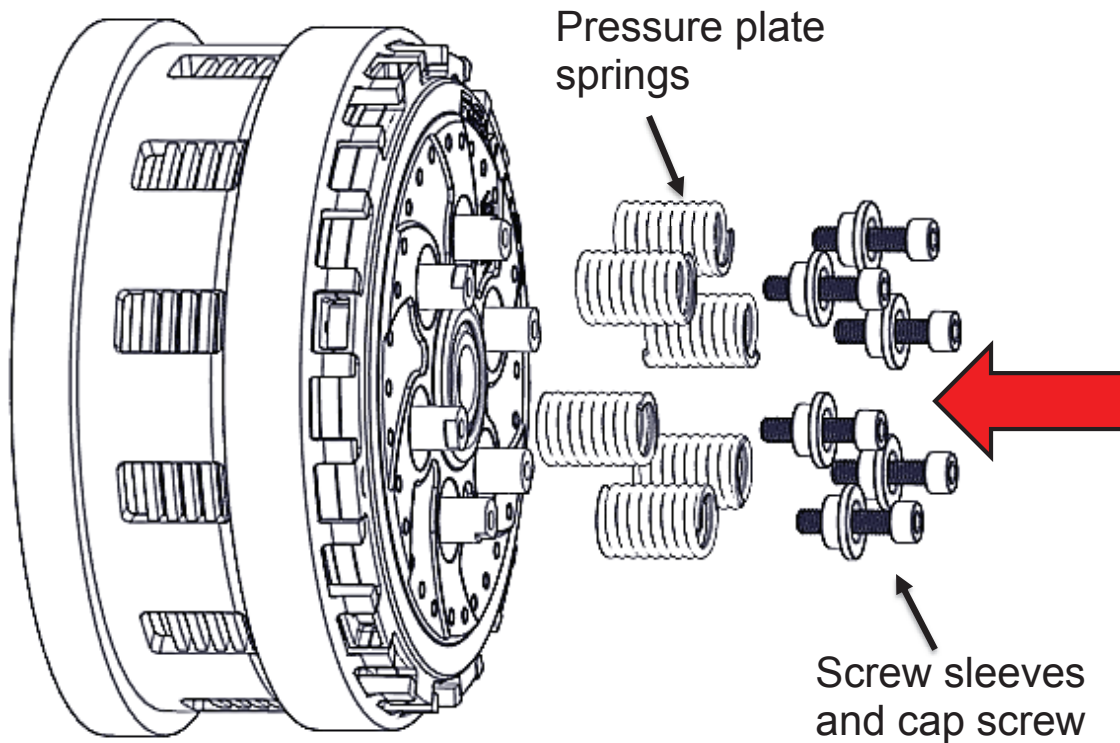

6. Install the provided clutch cover gasket onto the clutch cover.
7. Reinstall the clutch cover, copper crush washers, and cover bolts. *Be sure to reinstall the crush washers with the bolts in the proper locations.*
8. Lightly tighten the clutch cover bolts in a star pattern. Torque the bolts in small increments before tightening the bolts to 10 N-m as per specification found in the Yamaha service manual.
9. Reinstall the center console body panels, the driver seat, and the passenger seat.

SET THE INSTALLED GAP

The “Installed Gap” is the separation created when the pressure plate lifts from the clutch pack. The gap is created by adjusting the adjuster screw in the slave cylinder.

This gap is what allows the clutch to spin freely until the desired RPM is reached for EXP engagement. It must be set correctly for optimal performance.

1. Locate the adjuster screw in the center of the adjustable slave cylinder.
2. Use a 4 mm hex key to turn the adjuster screw clockwise until it stops under light pressure. **This is your “starting point.”**

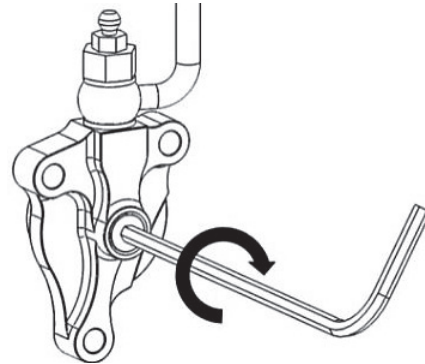
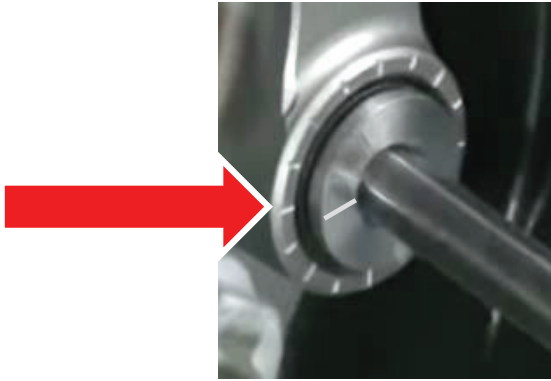

Note: *The resistance you feel is where the throw-out begins to lift the pressure plate. Finding the right starting point may take a few tries, but you will feel a noticeable change in turning effort once you reach that point. Stop when you feel the pressure increase. The “starting point” will change as the clutch pack wears over time.*

3. Once you have found the starting point, note the position of the hex key using the tick marks on the slave cylinder housing and the small etch mark located on the screw. You will begin here to adjust the installed gap.

4. Use a 4 mm hex key to turn the adjuster screw clockwise **1 full turn + 6 tick marks** from your starting point. *This results in 2 marks less than 1 and ½ turns.*



Use the tick marks on the cylinder and the etch mark on the screw to remember the starting point for adjusting the gap.

Note: *This may NOT be your final setting, but should allow you to get the correct gap measurement in the following step.*

MEASURE THE INSTALLED GAP

1. Using two sets of feeler gauges, try to slide in .035" (.89 mm) gauges **between** the lining plate and pressure plate, 180 degrees apart through the basket slots.

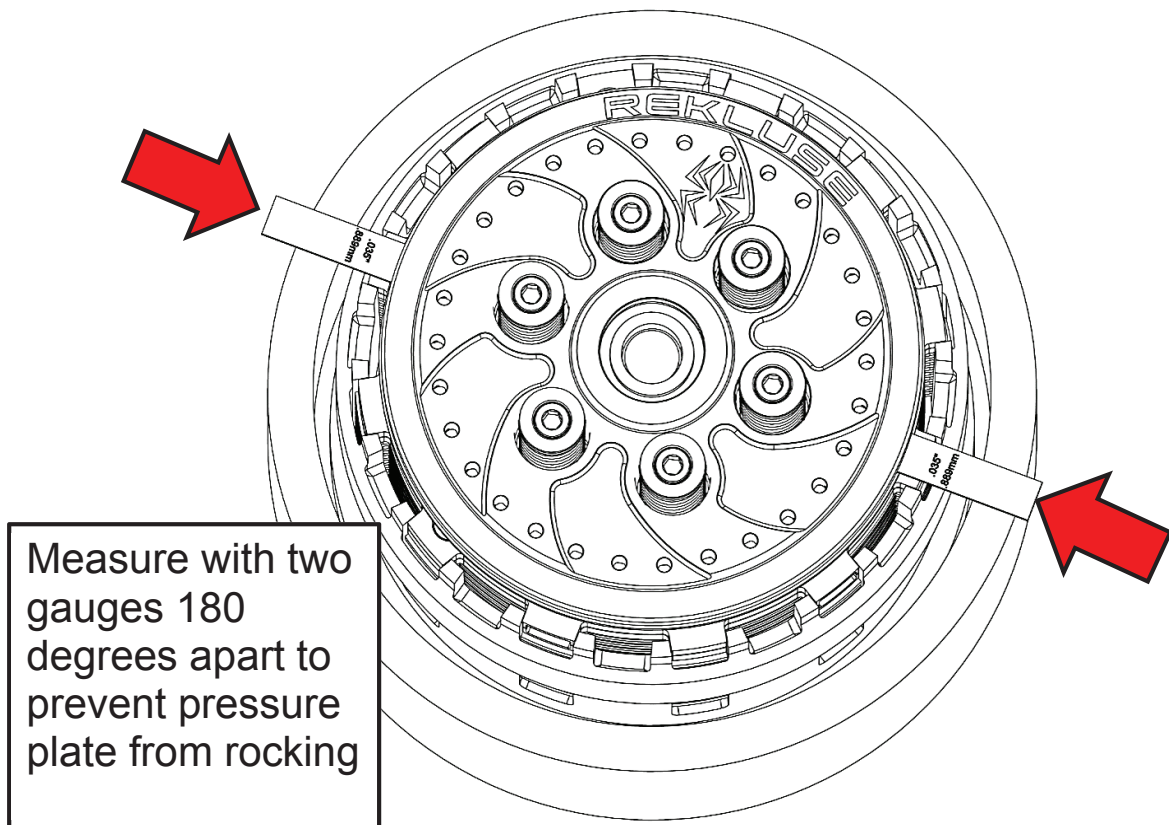

Note: You will need to push the lining plate off of the pressure plate down against the EXP disk in order to easily slide the gages in. **The gauges should have moderate drag when sliding in and out to signify proper measurement.**

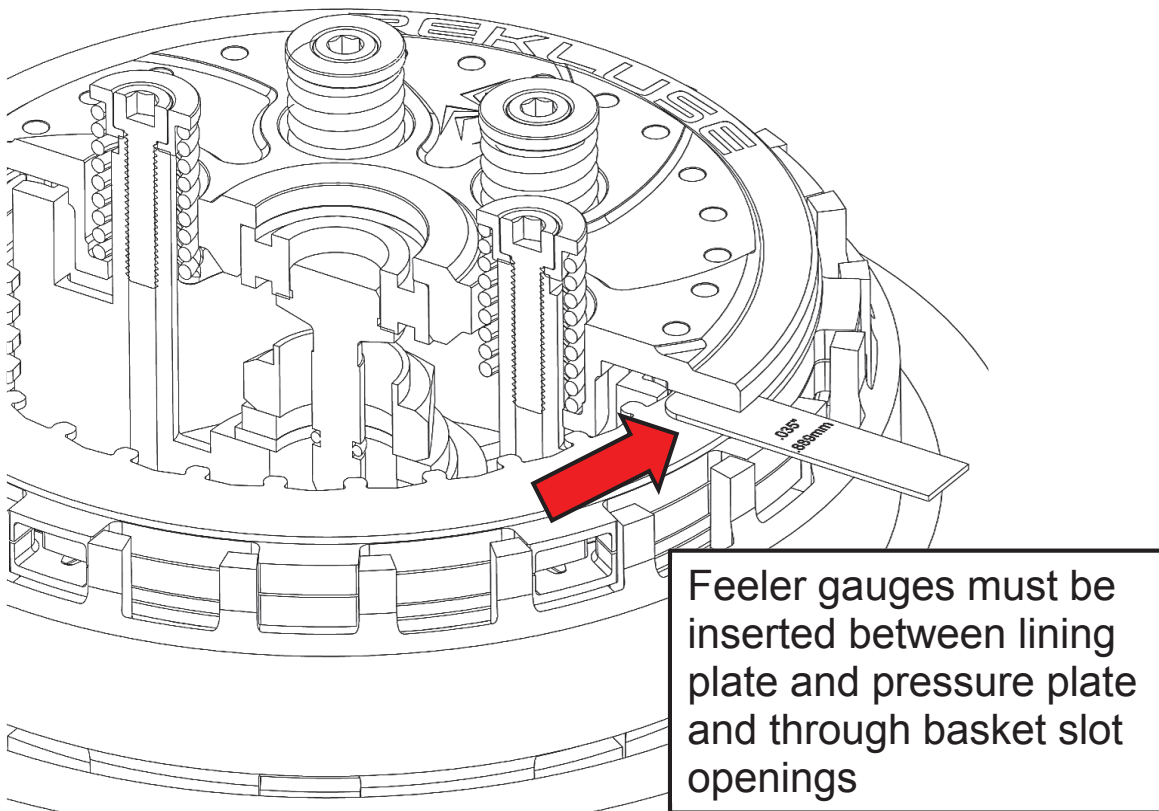

- a. If you cannot insert the gauges, turn the adjuster screw on the slave cylinder clockwise one tick at a time to increase the gap.
- b. If the gauges slide in easily with no resistance (drag), turn the adjuster screw one tick at a time counterclockwise to decrease the gap.

Note: Each tick mark engraved on the slave cylinder housing represents about .002" (.05 mm) of gap spacing change.

2. Continue to adjust the adjuster screw until you achieve a **.035" (.89 mm) installed gap measurement.**
3. Check fluid level in clutch master cylinder reservoir and fill if needed. Reinstall the reservoir cap.

4. Install the clutch cover with the new Rekluse cover gasket, then torque bolts to 10 N-m as per the specification found in the Yamaha service manual.

CLUTCH WARNING LABELS

1. Install the provided warning labels. Place the larger label on the door and the smaller label on the shifter console.
2. Understand the information contained in the safety information document included with your clutch prior to vehicle operation.

Note: *Warning labels must be installed in positions specified and maintained in order to make vehicle operators aware that a Rekluse Clutch has been installed.*

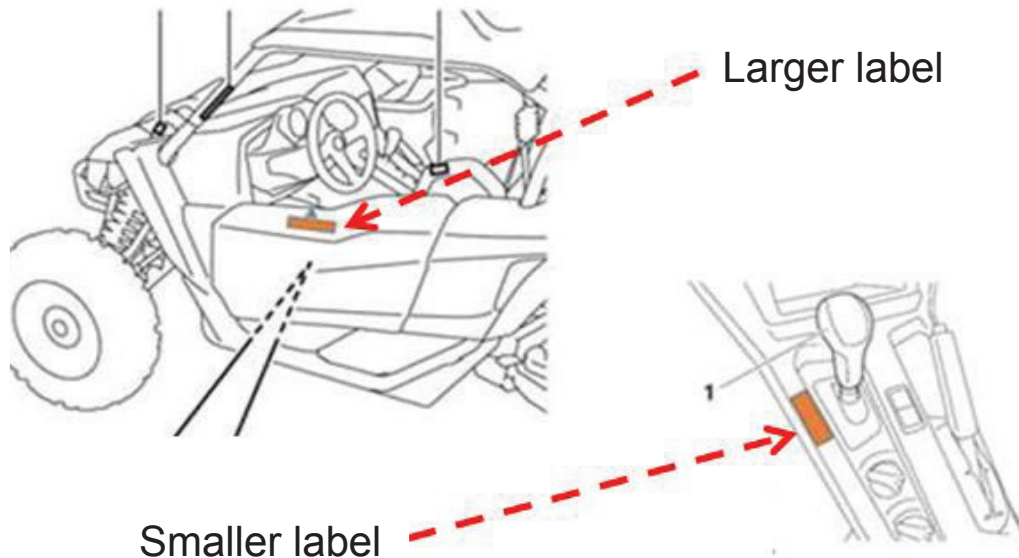

CHECK FOR FREE PLAY GAIN

Pedal free play is the “normal slack” in the clutch pedal before it starts actuating the clutch. Applying light pressure to the pedal takes up this slack.

“**Free Play Gain**” is an increase of pedal free play caused when the auto clutch engages. This happens when engine RPM increase from idle.

Free Play Gain is caused by the expansion of the EXP disk which lifts the pressure plate away from the throw-out assembly. A smaller installed gap setting results in more Free Play Gain than a larger installed gap setting.

An installed gap setting of .035" (.89-mm) yields approximately 1/4" (6 mm) of Free Play Gain when the engine is revved to at least 4,000 RPM.

Checking Free Play Gain is easy and takes less than a minute to perform. For optimum performance and longevity, check Free Play Gain when the vehicle is warm, prior to operation. Doing so will allow you to detect when an installed gap adjustment is needed to compensate for wear.

⚠ WARNING

Verify that the vehicle is in NEUTRAL before checking Free Play Gain. Failure to do so may result in the vehicle lurching forward, and loss of control and/or injury may result.

A Rekluse auto clutch can make your vehicle appear to be in neutral when in gear, even when the engine is running and clutch pedal released.

Vehicles equipped with a Rekluse auto clutch can move suddenly and unexpectedly and cause operators to lose control of vehicle.

To avoid death, serious injury, and/or property damage, always sit in the vehicle with seat belt or harness fastened to start it.

If the installed gap is set too tight excessive Free Play Gain can allow the clutch to drag and remain engaged when the engine is accelerated and while the clutch pedal is activated.

1. Place the vehicle in neutral, start the engine and let it warm up for 2-3 minutes.
2. Apply enough pressure to the clutch pedal to take up the normal pedal free play and perform the next step.

3. With the vehicle idling in neutral, quickly blip the throttle to rev the engine to at least 4,000 RPM and let it return to idle. **The clutch pedal should move in about 1/4" (6 mm) toward the floor as you rev the engine while applying light pressure.** If you detect more than 1/4" (6 mm) of Free Play Gain, you may not be able to fully override the clutch with the pedal at max engine speed (RPM).

Note: *Free Play Gain may be difficult to feel initially. If you are having difficulty detecting Free Play Gain, break-in the clutch as directed in the next section. After breaking in the clutch, see the "Troubleshooting" section of this document to adjust the Free Play Gain.*

BREAK-IN THE CLUTCH

Once you install your new clutch, it is important to break it in. Use the following procedures for breaking in your clutch and any time new friction disks, EXP bases, or wedges are installed.

The installed gap typically increases by approximately .005" (.13 mm) after initial break-in.

Note: *The acceptable installed gap range **after clutch break-in** is .038" (.965 mm) to .044" (1.12 mm). Setting the gap closer to .040" (1 mm) allows for more time between adjustments.*

Break-in Procedure	Number of times
<p>Rev Cycles:</p> <ol style="list-style-type: none"> 1. Warm up the vehicle for 2-3 minutes. 2. Place the vehicle in NEUTRAL. 3. With the vehicle in neutral, rev the engine 10 times, being sure to let it return to idle between each rev cycle. 	<p>① N ② ③ ④ ⑤</p> <p>10 rev cycles</p>
<ol style="list-style-type: none"> 4. With the engine still running, pull in the clutch pedal and place the vehicle into 1st gear. Slowly release the clutch pedal. The vehicle should stay in place or have a slight amount of forward creep. 5. With the vehicle idling in first gear, slowly apply throttle to begin moving, then release the throttle to come to a stop. 6. While in 1st gear, accelerate moderately to approximately 5,000 RPM and come to a complete stop. Repeat 10-15 times. <p>Note: <i>If the engine wants to stall or the creep is excessive, the idle may be too high or the installed gap may be too small. Make necessary adjustments before proceeding.</i></p>	<p>① N ② ③ ④ ⑤</p> <p>10-15 roll-on starts</p> <p>Continued on next page </p>

7. Place the vehicle in **NEUTRAL** and recheck Free Play Gain at your clutch pedal and adjust the installed gap if necessary.
8. You can also re-measure the installed gap to recheck Free Play Gain. The optimal post break-in installed gap setting is .040" (1 mm).

Note: *Your clutch pack will expand with heat, so final adjustment to Free Play Gain should be made when the vehicle is warm. Remember not to ride without sufficient Free Play Gain.*



Recheck Free Play Gain and adjust the installed gap

CAUTION

Do not operate vehicle without sufficient Free Play Gain. Operating the vehicle with too large of an installed gap—larger than .045" (1.14-mm) can result in clutch damage due to excessive slipping.

SHIFTING AND OPERATION

- Always use proper gear selection for the speed and situation when accelerating or slowing down.
- When accelerating from a stop, shift into 1st gear in order to prevent excessive slipping of the clutch. Starting in too tall of a gear repeatedly will prematurely wear out the clutch resulting in failure.

- Shifting without using the clutch pedal is possible with good timing similar to clutch-less shifting a manual clutch equipped vehicle.
- You can use the clutch pedal to fully over-ride the clutch at any moment. If you notice excessive clutch drag when the clutch pedal is engaged, the installed gap is too tight, or you may need to re-bleed the hydraulic clutch system.
- Do not leave the vehicle idling in gear while being operated for any period greater than 1-2 minutes. If the vehicle is left idling in gear for 5 minutes, the ECU will throw a code 42 activating the associated warning light. If this occurs, you can reset the system by performing the following step:
 - The ideal way to transfer code 42 into a past code is to drive the unit in 1st or 2nd gear for more than 5 minutes without depressing the clutch, shifting gears or coming to a stop. The engine warning light will shut off to indicate when the elapsed 5 minute time frame has been met.

Note: When operating the vehicle to turn off the code 42 warning light, keep the RPMs low and be mindful of the temperature light so as to not overheat the vehicle. Once the code 42 has been transferred to a past code, an authorized Yamaha dealer can erase the past code (if desired).

PARKING

Always engage the vehicle's parking brake to prevent the vehicle from rolling when unattended. With this product installed, the vehicle can now roll even when the transmission is in gear. Refer to the Safety Information document for more information.

▲ WARNING

Rekluse auto-clutch-equipped vehicles may roll back unexpectedly.

Vehicle will move in gear with the engine off because the clutch is only engaged when engine speed is above the engagement RPM of the auto-clutch. Engine compression will not prevent parked vehicles from moving while in gear.

To avoid death, serious injury, and/or property damage:

- Use vehicle parking brake to prevent vehicle from moving when parked.
- Avoid parking on steep inclines with the vehicle parallel to the incline direction. The tires may skid and cause the vehicle to become unstable when the parking brake is applied.
- Always position the downhill tires firmly against a curb or other type of wheel chock.
- Engage the parking brake.
- Never leave the vehicle parked without a parking brake engaged.

ABOUT FREE-WHEELING

If the RPMs drop to an idle speed while in any gear, it is possible for the vehicle to begin free-wheeling. It may be possible to reach very high speeds coming down a hill in a very low gear because the auto clutch is disengaged (free-wheeling).

Downhill operation with higher auto-clutch engagement speeds requires adjustments to your driving style. For example, coming over the top of a hill in first gear and slowing to the point that the Rekluse auto clutch disengages the clutch, your vehicle will now be “free-wheeling” down the hill.

Points to remember:

- **Refer to the Safety Information sheet for more information.**
- The Rekluse auto clutch is engaged by engine speed and not wheel speed.
- Select a suitable transmission gear in consideration of your ground speed, engine RPM and terrain.
- Easy does it on the throttle at high speeds. If throttle is applied at a high speed, the Rekluse auto clutch will engage suddenly. In this situation, severe compression braking could cause an accident and/or engine damage.

- It may be possible to reach very high speeds coming down a hill in a very low gear.

CAUTION

It is important not to downshift while in a free-wheeling state or loss of control may occur when the clutch re-engages. Refer to the Safety Information sheet for more information.

MAINTENANCE

- Keep up with regular oil changes as per the vehicle manufacturer's recommendations. Clutch function and longevity depends on oil quality.
- For optimal clutch performance Rekluse recommends using fresh, clean oil that **meets JASO-MA** oil rating requirements.
- Inspect all of your clutch parts at regular engine service intervals for signs of wear or excessive heat, and replace components as necessary.
- Excessive heat or clutch slip can cause premature clutch failure. Once extreme temperatures are reached, irreversible damage will occur. Inspect your clutch plates. If the friction plates look burnt or glazed, or the drive plates are warped, it is best to replace the entire clutch pack.
- Repeat the break-in procedure anytime the friction plates, EXP bases or wedges are replaced. Always soak new friction plates or new EXP bases in oil for at least 5 minutes before installing.
- If you find yourself making frequent slave cylinder adjustments to fix Free Play Gain, drag, or performance issues, the clutch pack may need to be replaced.

- EXP disk minimum allowable thickness = **0.416" (10.57 mm)**

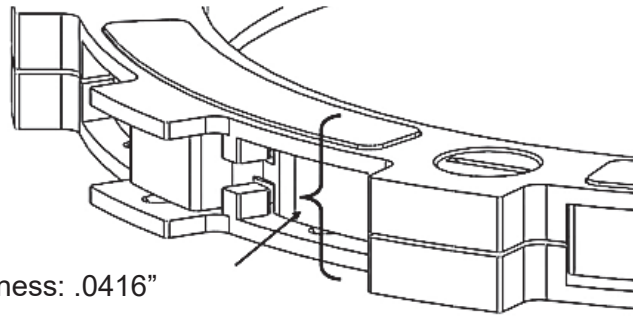

Minimum thickness: .0416"
(10.57 mm)

- Friction height = **Min: 0.115" (2.92 mm)**
Max: 0.121" (3.08 mm)
- Friction wear limit (specified by Yamaha): **0.1102" (2.8 mm)**
The wear limit is the absolute minimum thickness before a friction disk needs replacing.

TROUBLESHOOTING

Symptom:

- Clutch pedal moves in too far (too much Free Play Gain)
- Clutch has excessive drag
- It is difficult to fully override the clutch with the pedal

Answer: Installed gap is too small

Solution: Turn the adjuster screw on the slave cylinder clockwise to increase the installed gap. Each adjustment should be done in small increments – 1-2 tick marks at a time. After each adjustment, check Free Play Gain until the ideal installed gap is achieved.

Symptom:

- Clutch pedal does not move enough or does not move at all (too little Free Play Gain)
- Clutch is slipping

Answer: Installed Gap is too large

Solution: Turn the adjuster screw counterclockwise to reduce the installed gap. It may be helpful to re-find the starting point.

Note: *The ideal post break-in gap range is: .038" (.965 mm) to .044" (1.12 mm).*

Clutch noise and drag

Although it is harmless, the clutch may “squeal” or “chatter” at low RPM as it engages. Clutch squeal is caused by the clutch components vibrating as the clutch engages and can become more audible as the clutch gets hot. If you notice clutch squeal or chatter here are some recommendations to reduce or eliminate it:

- **Oil:**

Dirty or over used oil can make the clutch more likely to squeal or chatter. Some heavy-duty oil stabilizers or other additives have been known to reduce noise and make shifting smoother. Be sure that any additives you might use do not affect the friction properties of the oil.

Rekluse recommends using JASO-MA or JASO-MA2 certified oil for best clutch performance. Heavier weight oils that are JASO-MA certified, such as Yamalube 20W50, typically provide best performance.

- **Drag:**

It is possible for the clutch to drag noticeably when cold. If this occurs, warm the vehicle up by allowing it to idle for a few minutes before operating. If drag persists verify the installed gap is correct.

BUMP-STARTING INSTRUCTIONS

If your vehicle needs to be bump-started due to a dead battery or any other reason, follow the steps below to quickly bump-start your vehicle.

1. Use a 4 mm hex key to turn the adjustment screw counterclockwise, just until it turns freely. This removes the installed gap and locks the clutch.
2. Bump start the vehicle. The clutch will function like a manual clutch at this point, but the clutch will not be fully over-rideable at high RPMs.
3. Once the vehicle is started, readjust the gap to set the installed gap.

NEED ADDITIONAL HELP?

Website

www.rekluse.com/support

Frequently Asked Questions

www.rekluse.com/faq

Support Videos

www.rekluse.com/support/videos

Phone

(208) 426-0659

Technical Support

Contact Technical Support for questions related to product installation, tuning, and performance.

Hours:

Monday thru Friday: 8:00 a.m. - 5:00 p.m.

Mountain Time zone

Email: tech@rekluse.com

Customer Service

Contact Customer Service for additional product information, orders, and returns.

Hours:

Monday thru Friday: 8:00 a.m. - 5:00 p.m.

Mountain Time zone

Email: customerservice@rekluse.com

