



REKLUSE[®]
RADIUS[™]**cx**

INSTALLATION & USER'S GUIDE

RadiusCX Clutch
for DS Betas

Doc ID: 191-7902122A
Revision: 110221

Table of Contents

OVERVIEW	3
INSTALLATION TIPS	3
TOOLS.....	4
INCLUDED PARTS	4
DISASSEMBLE CLUTCH.....	5
INSTALL THE HUB	10
INSTALL THE CLUTCH PACK	12
Notes for installation.....	12
INSTALL THE CLUTCH COVER	15
SLAVE CYLINDER INSTALLATION	15
BLEED THE CLUTCH LINE	23
SET THE INSTALLED GAP AND CHECK FREE PLAY GAIN ...	26
Step 1: Find the starting point	27
Step 2: Learn how to check Free Play Gain	28
Two Ways to Check for Free Play Gain	30
The Rubber Band Method.....	30
The Hand Method.....	32
Step 3: Break-in the new clutch	34
Step 4: Adjust the installed gap and Recheck Free Play Gain	37
FREE PLAY GAIN ADJUSTMENTS	38
LEVER SAFETY STRAPS	39
MAINTENANCE.....	39
Disk inspection examples.....	41
TROUBLESHOOTING	42
Performance issues.....	42
Clutch noise.....	42
EXP TUNING OPTIONS	43
Changing the springs	44
BUMP-STARTING	46
NEED ADDITIONAL HELP?.....	47

OVERVIEW

This kit replaces many of the OE (Original Equipment) or “stock” clutch parts. The following is a summary of what is replaced:



- This kit will replace all the OE frictions and drive plates with a Rekluse thin friction EXP clutch pack.
- The OE pressure plate springs are replaced with high quality Rekluse springs.
- OE center clutch and pressure plate components are replaced with Rekluse Core components.

INSTALLATION TIPS

- Read the separate included Safety Information document before operating the vehicle with the product installed.
- Read this entire document before performing any steps.
- If you install this product for a customer or another person, instruct them to read the **Safety Information** document and the **Installation and User Guide** before operating the bike with the product.
- Protect eyes and skin – wear safety glasses and work gloves.
- Lay the motorcycle on its left side when replacing the clutch. This makes the clutch work easier and eliminates the need to drain the oil. Catch any fuel that may drain from the bike.
- Use the torque values listed in the instructions. Otherwise, use the torque specifications found in your OE service manual.
- For optimal clutch performance Rekluse recommends using fresh, clean oil that **meets JASO-MA** oil rating requirements. Rekluse offers Factory Formulated Oil™ developed specifically for Rekluse products. Rekluse Factory Formulated Oil is a perfect complement to any OEM or aftermarket wet clutch. Visit www.rekluse.com to learn more.



TOOLS

 10 mm	 8 mm		
10 mm socket	8 mm socket	Metric Wrench	Torque Wrench
			
Pick	Fluid Catch Container	27mm socket	Channel lock pliers
	 4 mm	 5 mm	
Hammer	4 mm Hex key	5 mm Hex key	

INCLUDED PARTS

The parts included in the kit depend on the bike model. See the **Setup Sheet at the back of this manual** for a list of included parts and illustration.

You can also visit our website at www.rekluse.com/support for a full parts fiche illustration and part numbers.

DISASSEMBLE CLUTCH

1. If your bike is carbureted, turn the fuel petcock to “OFF.”
2. Shift the transmission into 5th gear.
3. Lay the bike on its left side. Catch any fuel that might drain in a suitable container.
4. Remove the break pedal spring from the clutch cover.



5. Using an 8 mm socket, remove the OE clutch cover. Pay close attention to the length and location of the OE screws so they can be returned to their same location.

Note: Clean and set aside the OE cover gasket if OE equipped. The OE cover gasket will be reused.

6. Using an 8mm socket, remove the pressure plate bolts, hold down ring, Belleville Spring and seat, then remove the pressure plate.

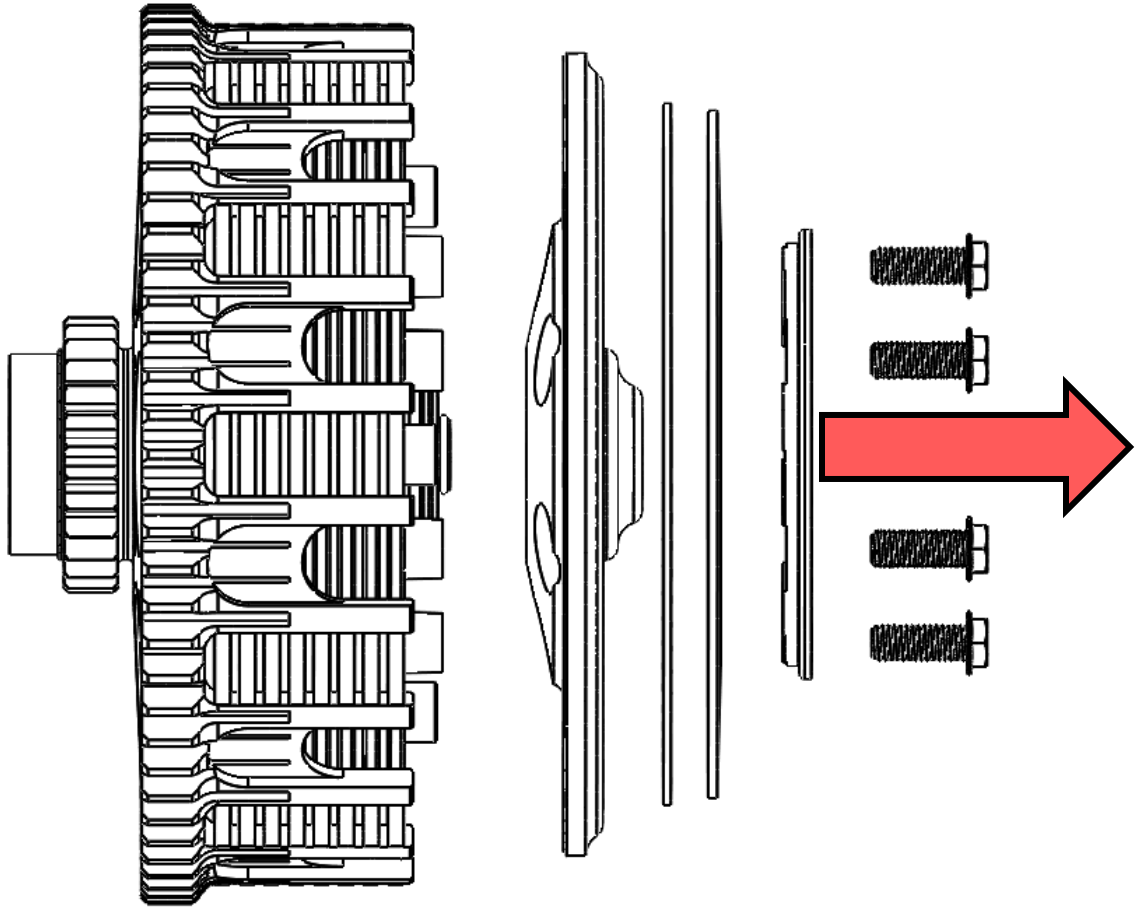

7. Remove the OE clutch pack, then set it aside. The pack will not be reused. Use a pick if necessary to help remove the clutch pack.

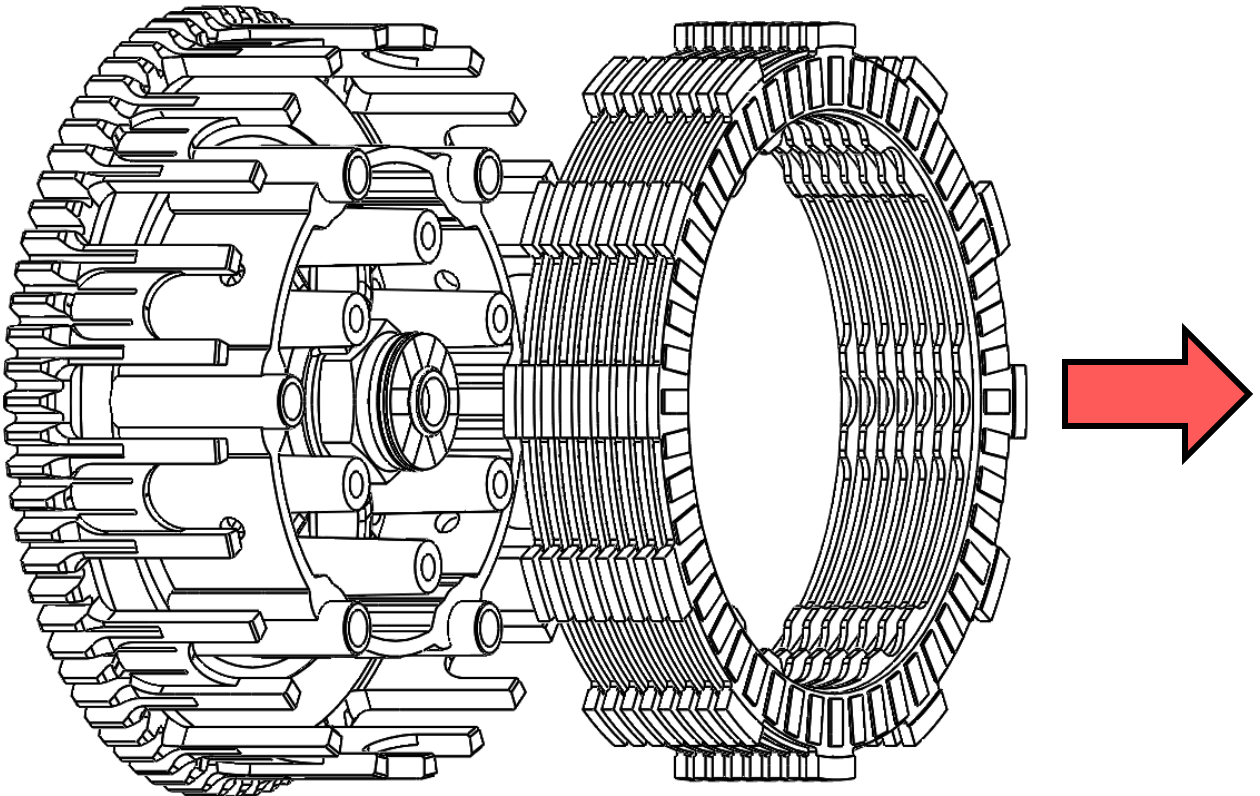

8. Remove the 6 drive pins. Set these aside. The drive pins will be reused.

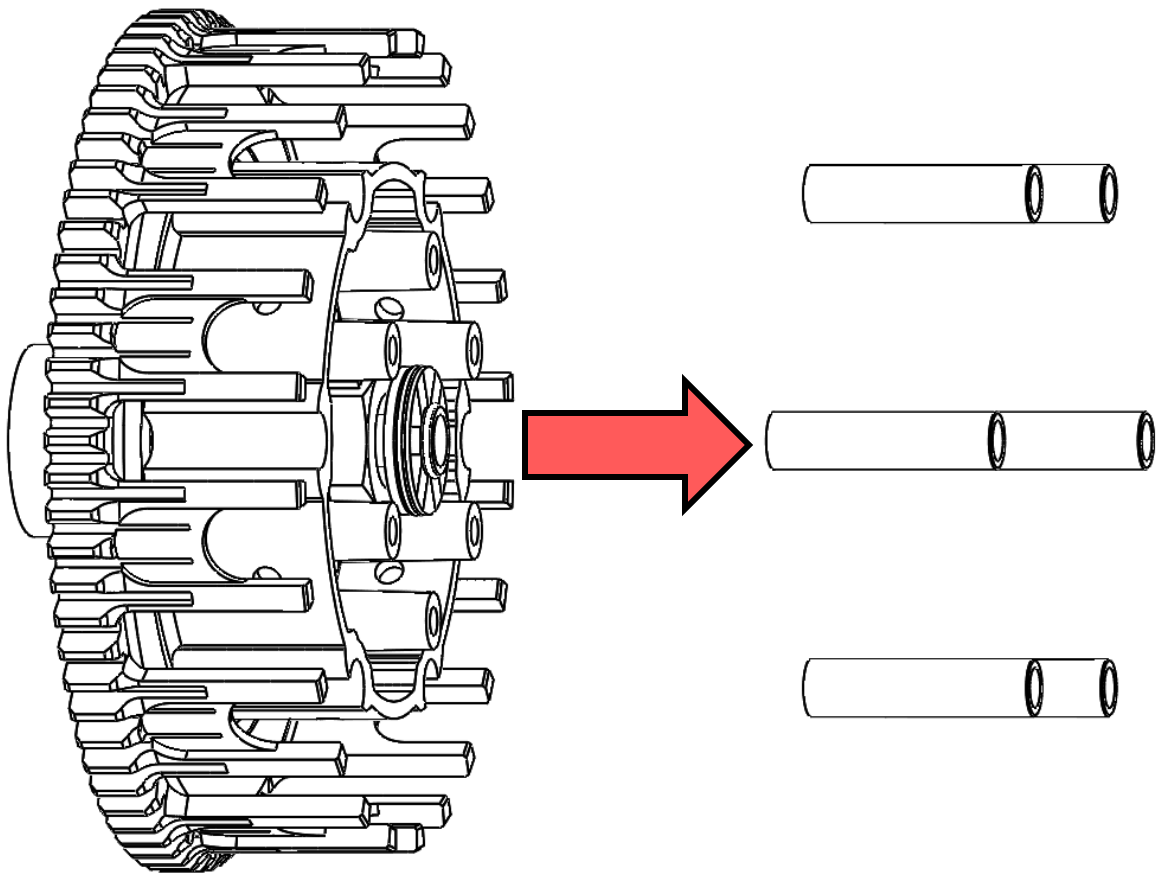

⚠ CAUTION

Be careful the drive pins do not fall into the engine while disassembling.

9. Inspect the clutch basket for notching or wear. If the basket is notched or worn, replace the basket.

⚠ WARNING

Failure to inspect the basket and replace if necessary could result in death, serious injury, and/or property damage.

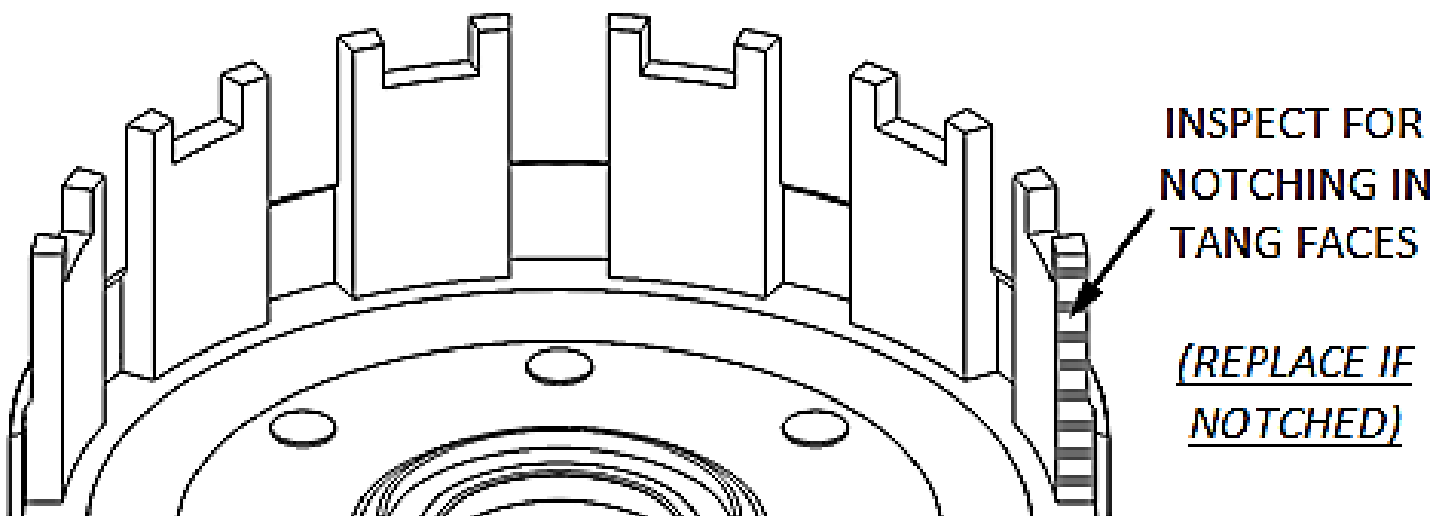

10. Remove the throw-out assembly and throw-out rod and set it aside. The throw-out assembly will be reused. The throw-out rod will not be reused

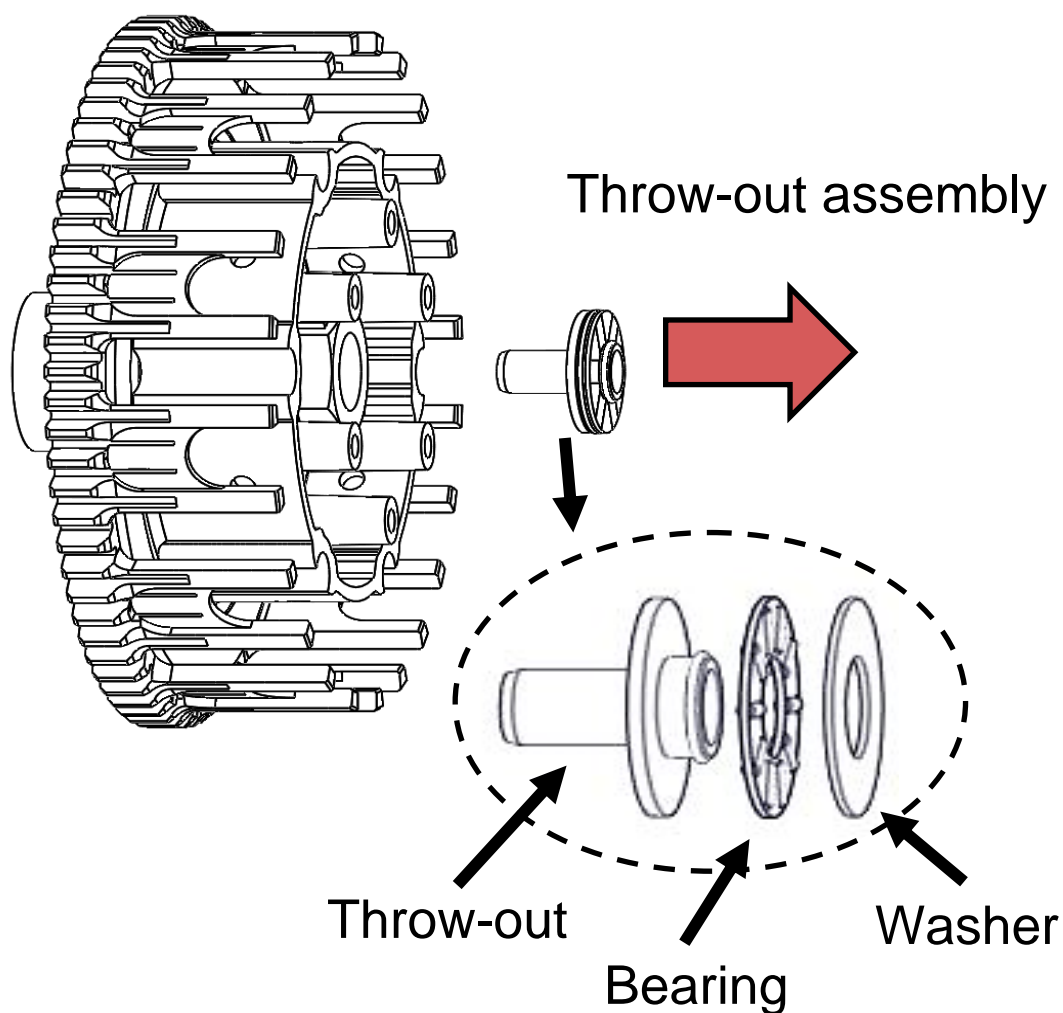

11. Use a hammer and large screwdriver to bend down the edges of the washer tab until it clears the clutch nut.

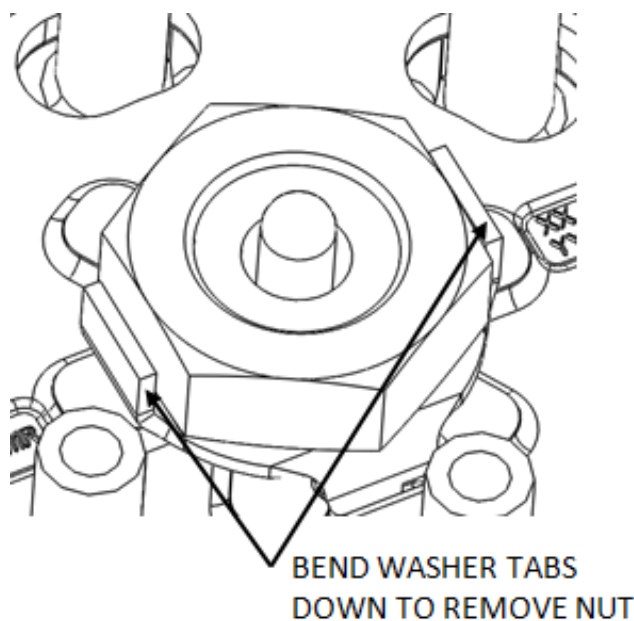

12. Remove the center clutch nut with an impact wrench or breaker bar, and socket. Set aside. The OE clutch nut will be reused.

Note: *Placing the bike in the highest gear and holding the rear wheel by applying the rear brake keeps the shaft from rotating when removing the nut.*

13. Remove the washer located under the center clutch nut and the center hub from the clutch basket while leaving the thrust washer underneath on the main shaft. The OE washer will be replaced with a Rekluse tab lock washer.

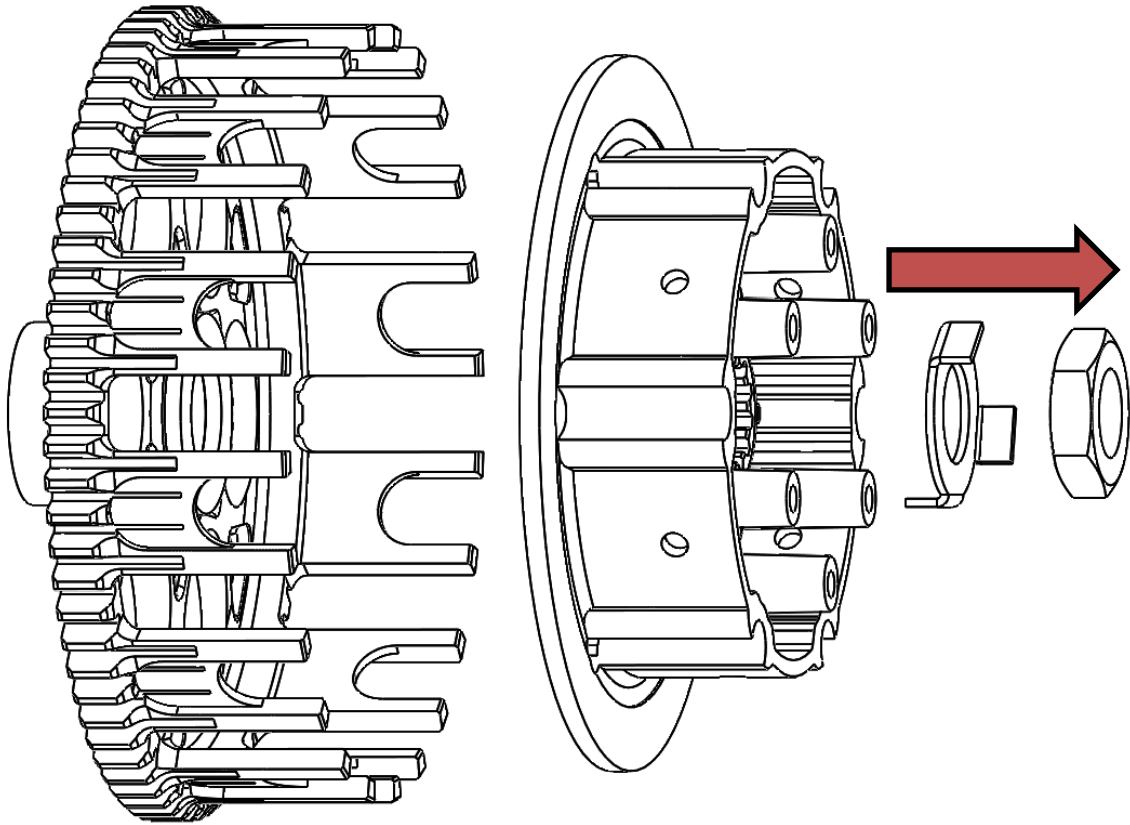

Note: Check that the OE thrust washer is still on the main shaft and not stuck to the bottom of the center hub assembly. The thrust washer must be installed or clutch performance issues will result.

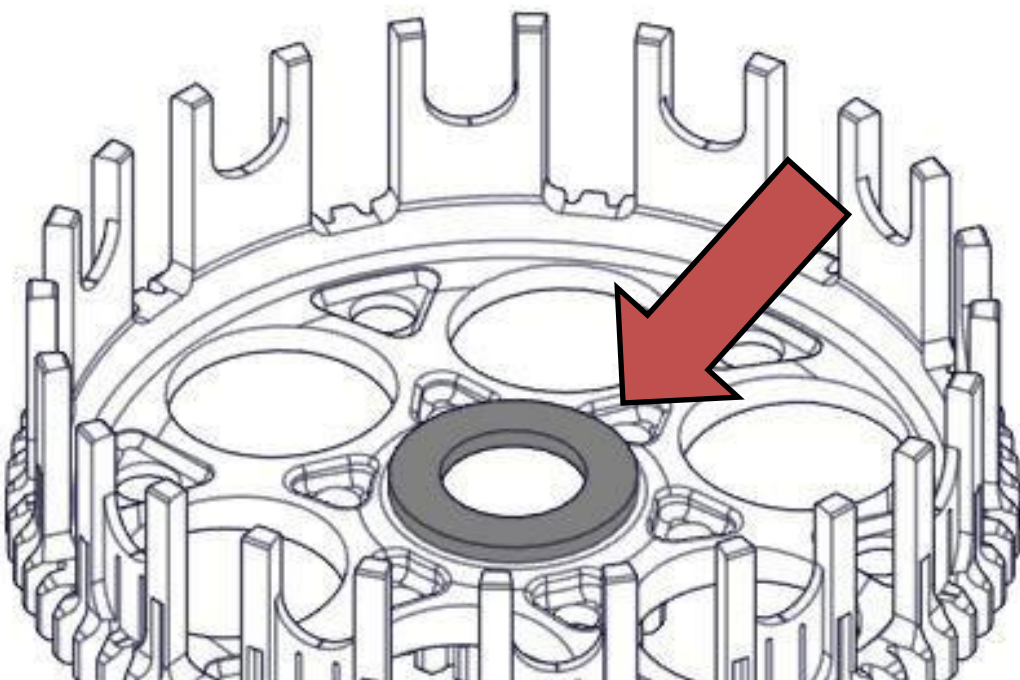

INSTALL THE HUB

1. Install the new Rekluse center hub into the clutch basket.

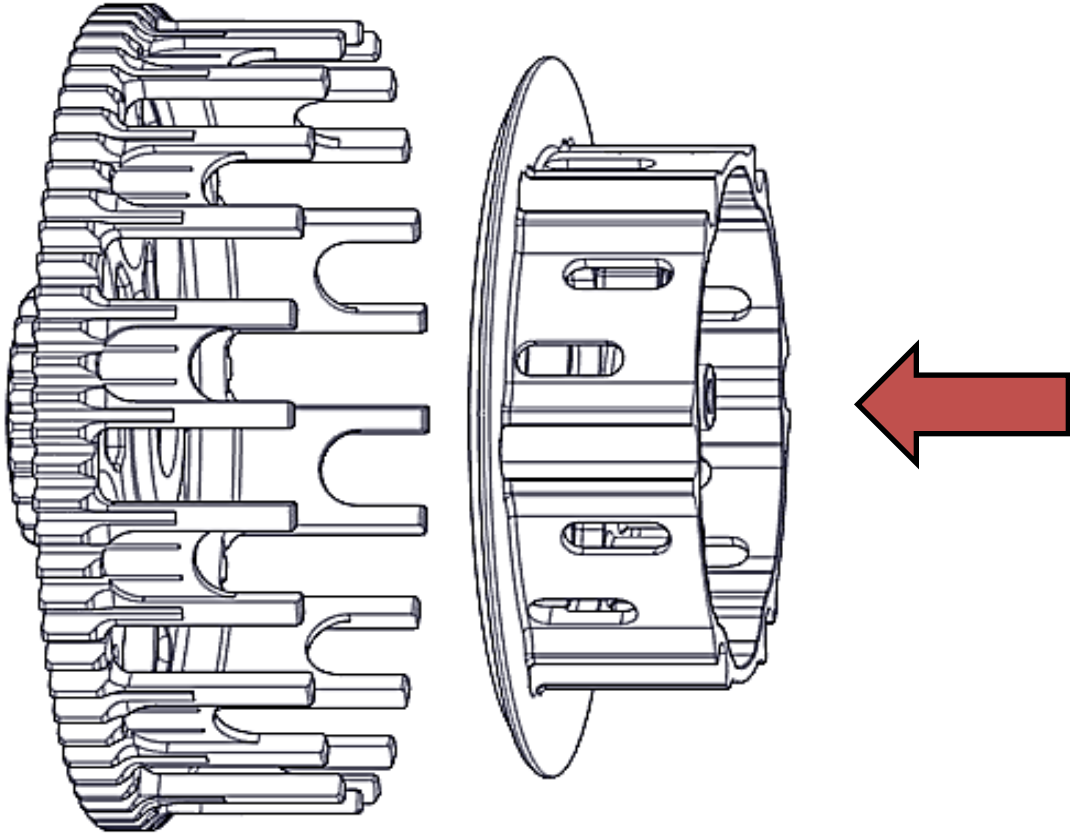

2. Install the new Rekluse tab washer with the bent tabs facing down, aligning with the holes in the hub.



3. Reinstall the OE clutch nut.

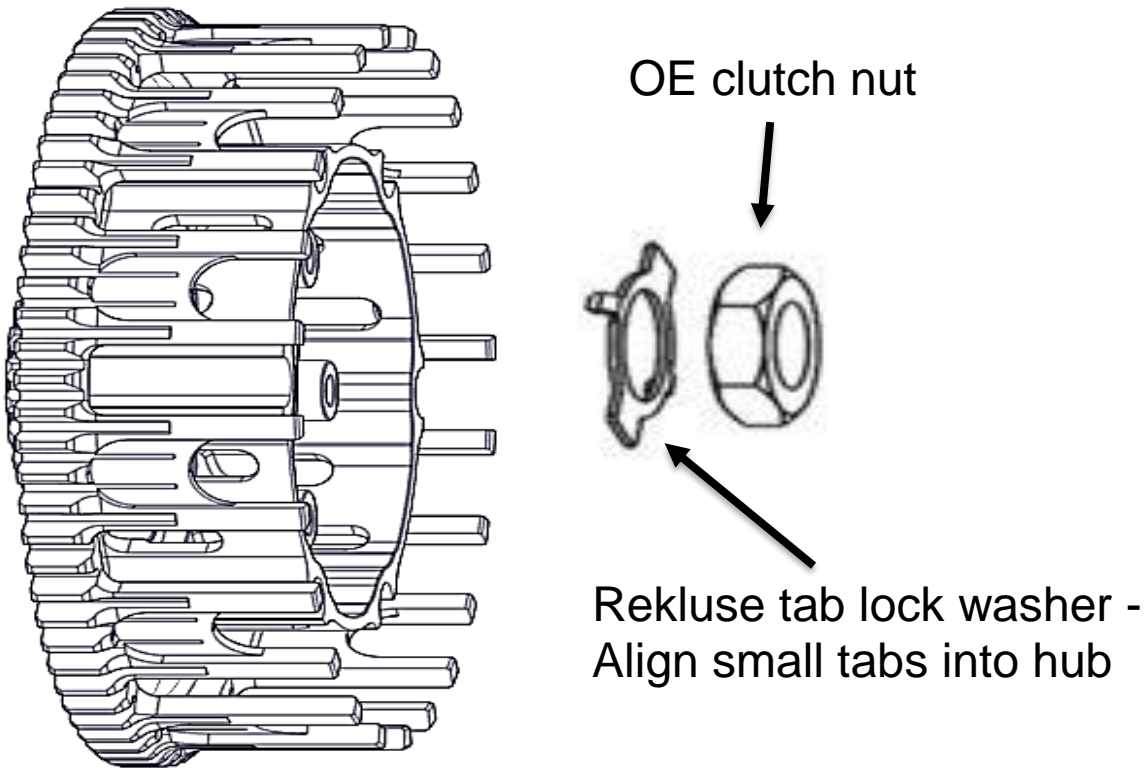

4. Using the socket and torque wrench, torque the center clutch nut to **50 ft-lb (68 N-m)**.

Note: *Placing the bike in the highest gear and holding the rear wheel by applying the rear brake keeps the shaft from rotating when tightening the nut.*

5. Using the channel-lock pliers, bend up **both** tabs of the tab washer tightly around the nut. The tabs can be bent on the straight sides or around the corners.

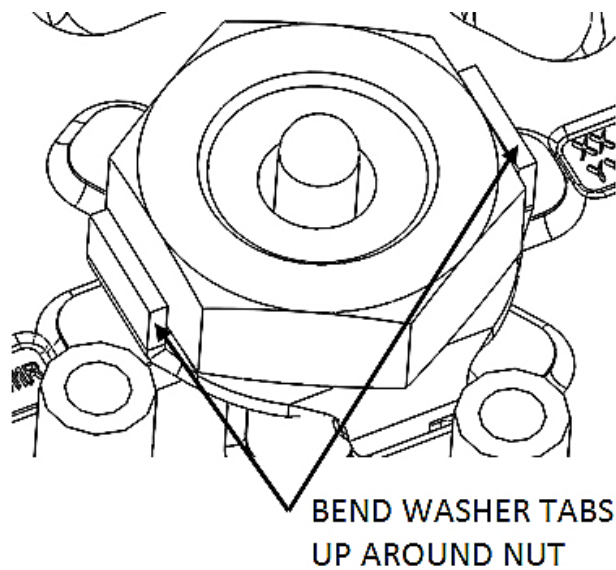

INSTALL THE CLUTCH PACK

Each clutch pack comes with a set of steel drive plates, a set of TorqDrive® friction disks, and an EXP disk.

Notes for installation

- *Some friction disks are marked with a small colored dot. This mark is used for processing and can be ignored.*
- *Some OE basket have “half slots” at the top of the basket tangs. Rekluse products require that the entire clutch pack, including the EXP disk, be installed into the MAIN (deeper) basket slots. Do not use the “half-slots.”*

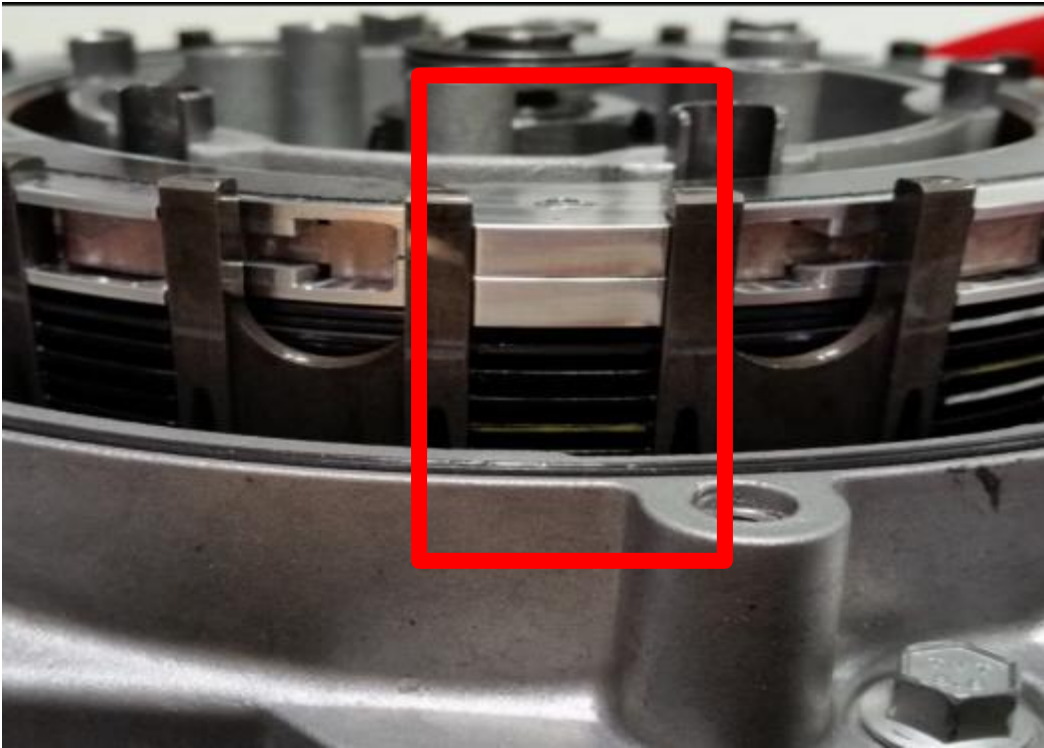

1. Soak the EXP disk and friction disks in new engine oil for 5 minutes. Make sure the EXP and friction disks are coated in oil on both sides.

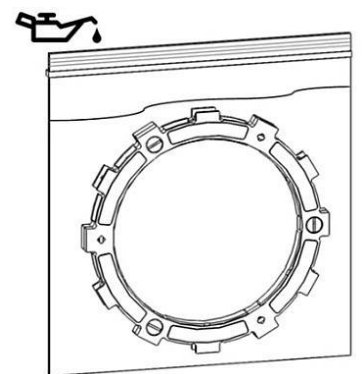

2. Install the 6 OE drive pins into the Rekluse Center hub, into the cut channels for the pins.

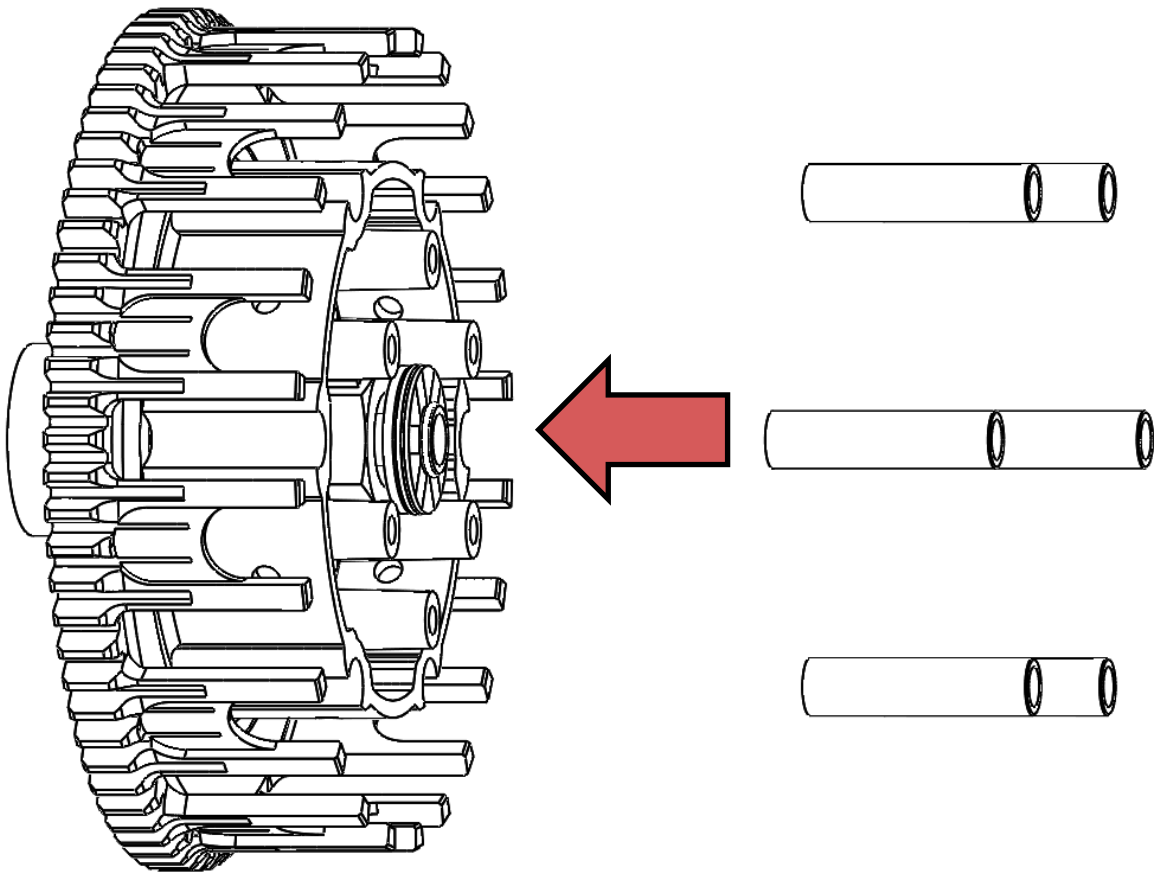

3. Install the clutch pack one plate at a time according to the order in **Setup Sheet** at the back of the manual.
4. Install the Rekluse provided throw-out rod. The throw-out will assemble onto the smaller end so install the larger end in first.
5. Reinstall the OE throw-out assembly. If the washer is missing, check to see if it is stuck to the underside of the pressure plate.

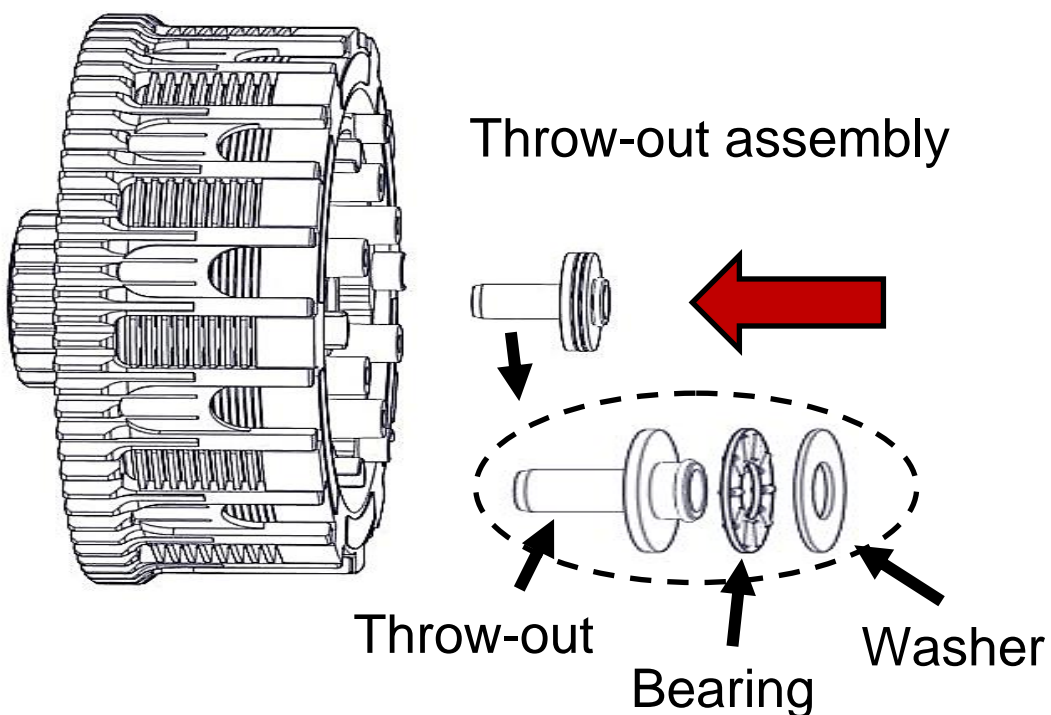

Note: To help with the lining plate installation, turn the pressure plate over and place a thin layer of oil between the lining plate and the pressure plate. This will help hold the lining plate in place while installing the pressure plate over the clutch pack.

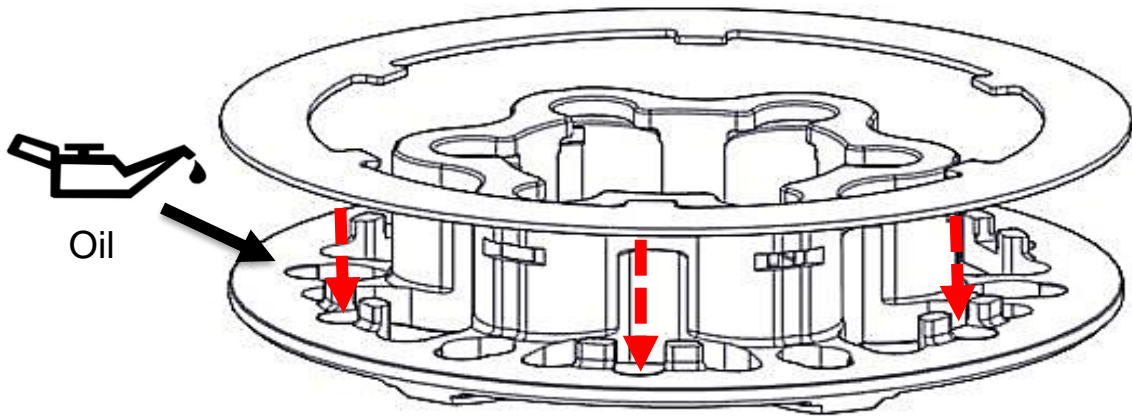

6. Install the Rekluse pressure plate, pressure plate springs, screw sleeves, and pressure plate bolts.

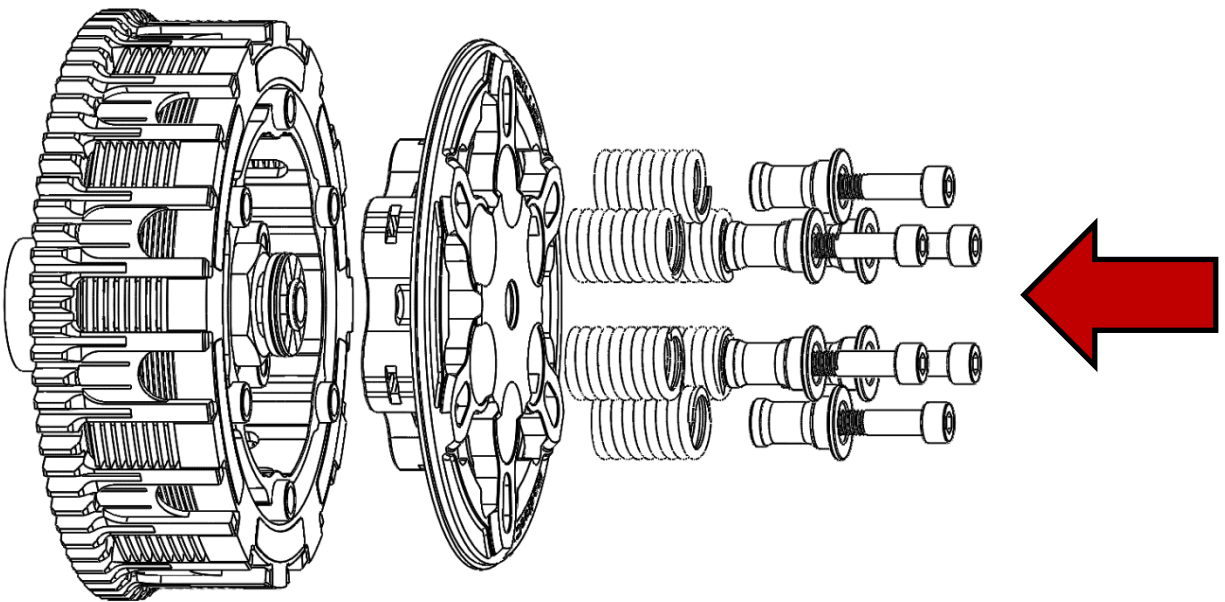

CAUTION

Do not reuse the OE springs or bolts. They are not compatible with the Rekluse core parts.

Note: Be sure to alternate springs if you are using two different color springs to keep even pressure on the clutch. Heavier springs are available for purchase from Rekluse.

7. Using a torque wrench, tighten the pressure plate bolts to 9 ft-lbs (12 N-m).

INSTALL THE CLUTCH COVER

1. Reinstall the OE cover gasket, if equipped. If your kit includes an O-ring cord, install it into the Rekluse clutch cover first, using small dabs of grease to hold it in place.
2. Place the Rekluse clutch cover onto the bike by lightly tightening the cover bolts in small increments in a star pattern. Be sure to return the bolts in the same location they were removed.

⚠ CAUTION

Failure to install the OE clutch cover bolts back in their proper location can result in damage to your motorcycle.

3. Torque the cover bolts to 9 ft-lbs (12 N-m).
4. Reinstall the break pedal spring onto the clutch cover.

SLAVE CYLINDER INSTALLATION

Installing the new Rekluse slave cylinder takes several steps. Please read the entire section before beginning the process to ensure you have the right equipment and clutch fluid needed for the replacement. Rekluse recommends wearing gloves and safety glasses for the install.

⚠ CAUTION

During the bleed and assembly, note that there is a small ball bearing installed in the slave piston with a small amount of grease. When installing the Rekluse slave cylinder, make sure the ball is in place and has not fallen out during shipping.

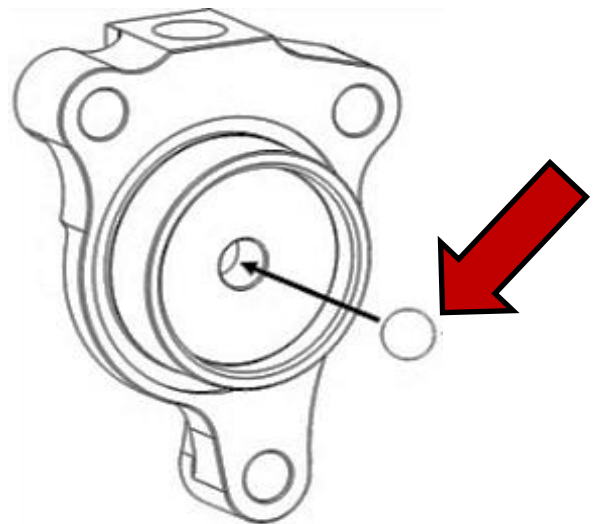

Step 1: Bleed the new slave cylinder

This step prepares the new slave cylinder for installation. Bleed the cylinder on a workbench or an area away from the bike.

1. Using a 4 mm Allen wrench, turn the adjuster screw counterclockwise so that the top O-ring is visible under the adjuster screw.

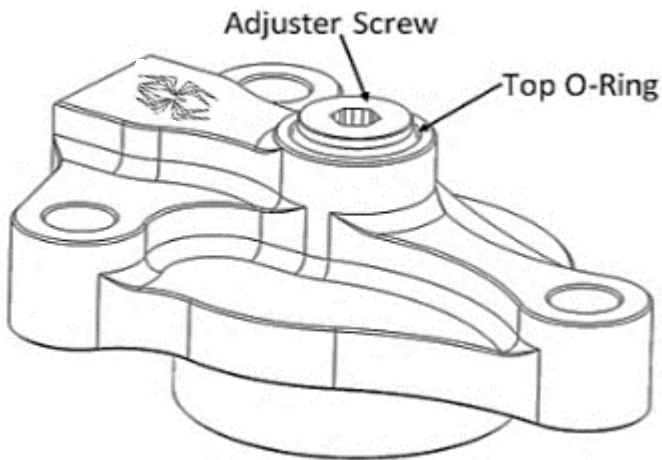

2. Use your thumbs to compress the piston until it bottoms out, then release it.

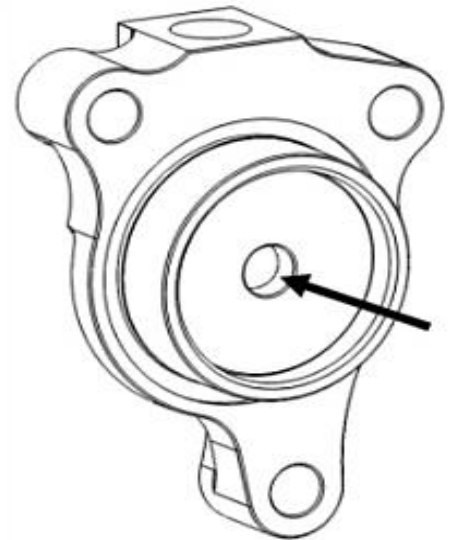

3. Pour the manufacturer recommended clutch fluid into the slave cylinder port.

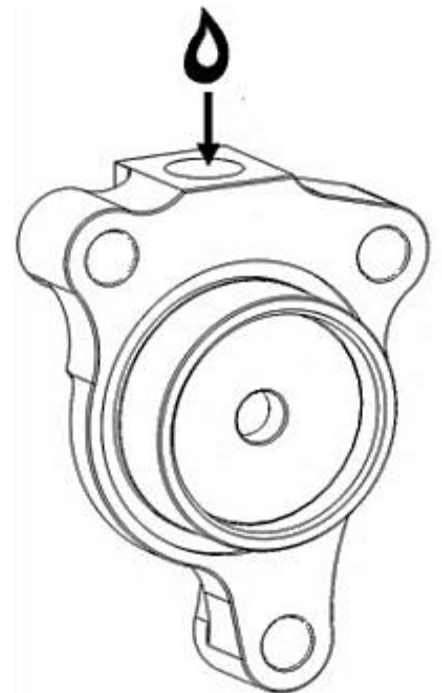

CAUTION

Be sure to use the correct clutch fluid. Check the cap of the clutch master cylinder to determine which clutch fluid to use. Failure to use the correct fluid will result in seal damage and/or failure.

4. Use a 4 mm Allen wrench to turn the adjuster screw clockwise until it bottoms out and the O-ring is no longer visible. Keep the fluid topped off as you go.

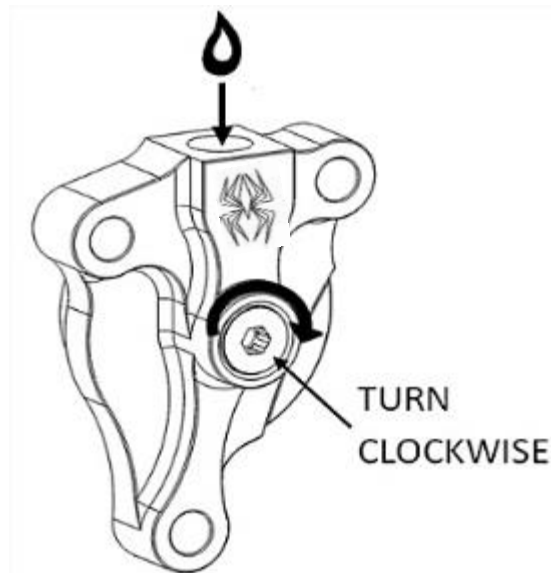

5. Use the wrench to turn the adjuster screw counterclockwise back to the initial position, with the top O-ring visible. Keep the fluid topped off as you go.

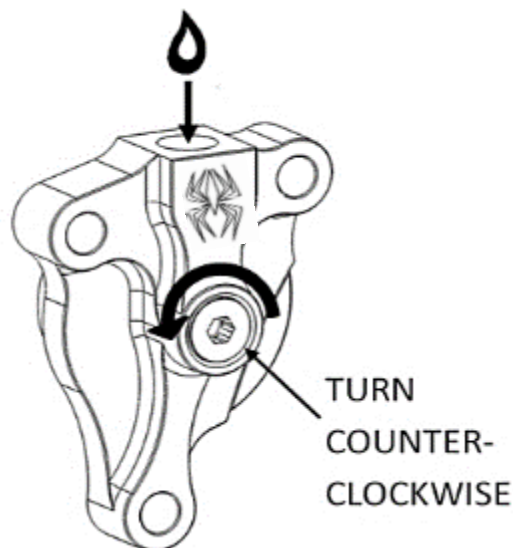

6. Use your thumbs to compress the piston again until it bottoms out while looking for air bubbles.

⚠ CAUTION

When compressing the piston, fluid can shoot out from the slave cylinder port. Be sure to wear eye protection.

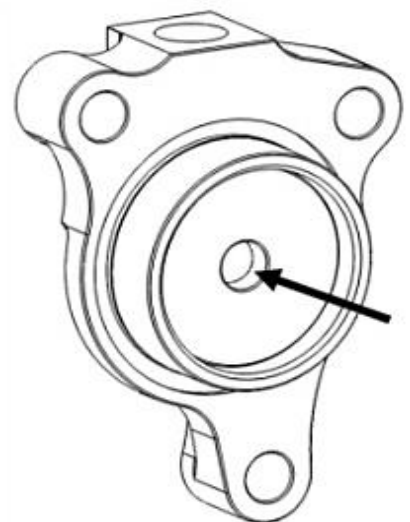

7. Repeat steps 3 - 6 until there are no air bubbles coming out in the fluid when the piston is compressed.
8. When the bleeding is complete, turn the adjuster screw counterclockwise so that the top O-ring is visible.
9. Compress the piston until it bottoms out, and top off with fluid.
10. Check that the ball bearing is still in place in the piston.
Stand the Rekluse slave cylinder in an upright position (so the fluid does not spill) until it is needed in the next step.

Note: *The Rekluse slave cylinder comes preassembled in the kit. If the parts become separated, assemble them in the following order: Rekluse slave cylinder, O-ring, then the supplied paper gasket.*

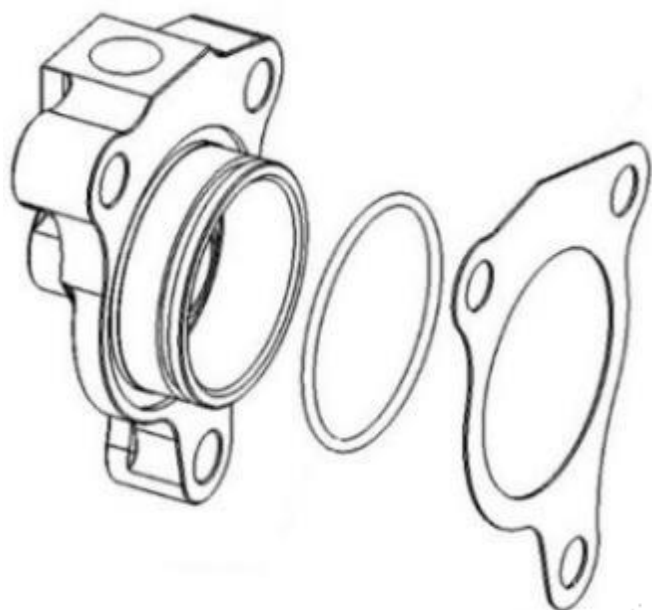

DO NOT put O-ring in this groove

Correct O-Ring groove

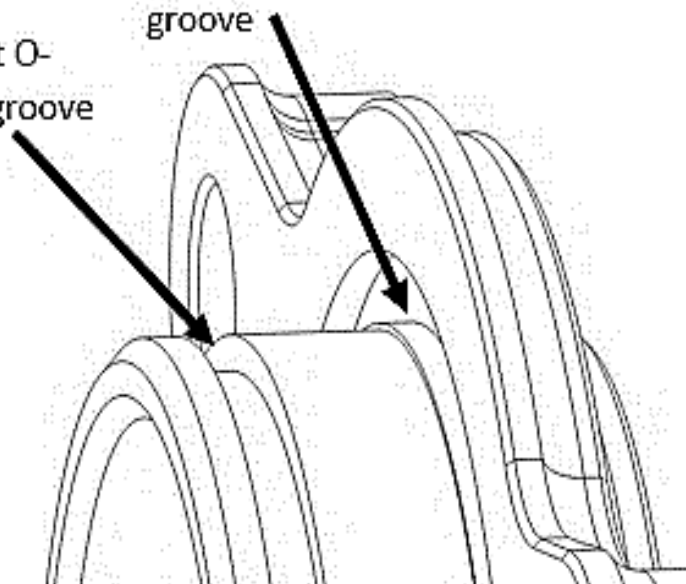

Note: Some models have a piston diaphragm seal. DO NOT reuse them if OE equipped. The Rekluse slave cylinder does not require a diaphragm seal.

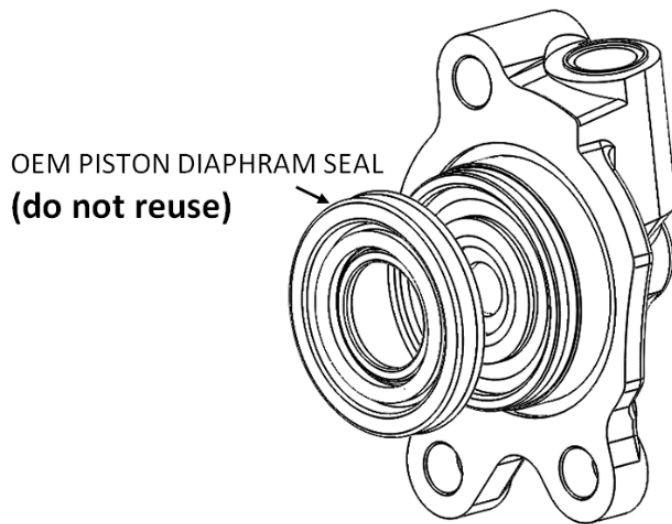

Step 2: Replace OE slave cylinder

In this step, the OE slave cylinder is replaced with the Rekluse slave cylinder. Work quickly when performing the following steps. This method retains the fluid inside the line, and makes the final bleeding step easier.

1. Stand the bike up and lean it on its kickstand, or place it on a suitable bike stand.

2. On the left side of the bike, while leaving the OE slave cylinder intact on the engine, use a wrench to remove the banjo bolt from the OE slave cylinder.

3. Remove the clutch fluid line and the 2 OE crush washers from the OE slave cylinder. Discard the OE crush washers.

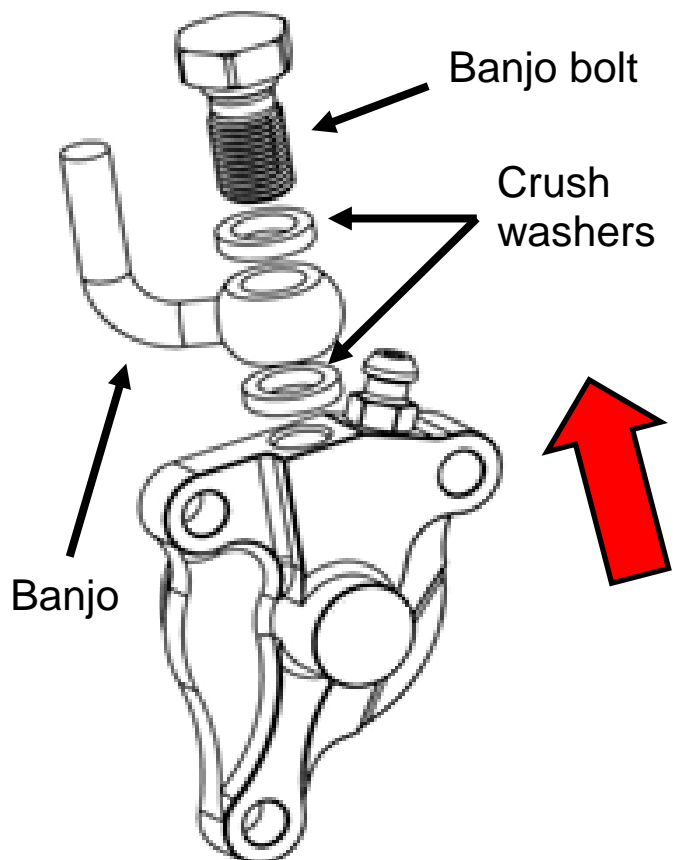

4. Attach the clutch fluid line to the Rekluse slave cylinder using the OE banjo bolt and the 2 new crush washers from Rekluse. Make sure the banjo is sandwiched between the 2 crush washers.

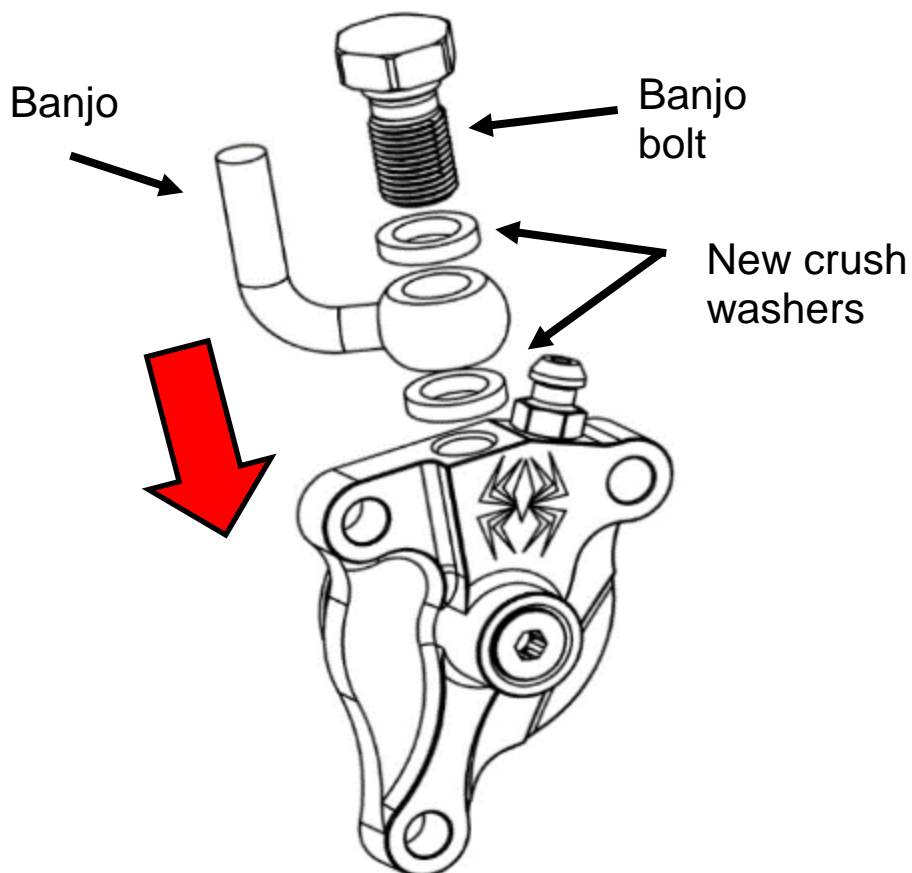

5. Tighten the banjo bolt with your hand until snug. (You will torque it to spec once installed on the bike.)

6. With the clutch fluid line attached to the Rekluse slave cylinder, remove the OE slave cylinder from the engine. Keep the OE bolts for reuse.

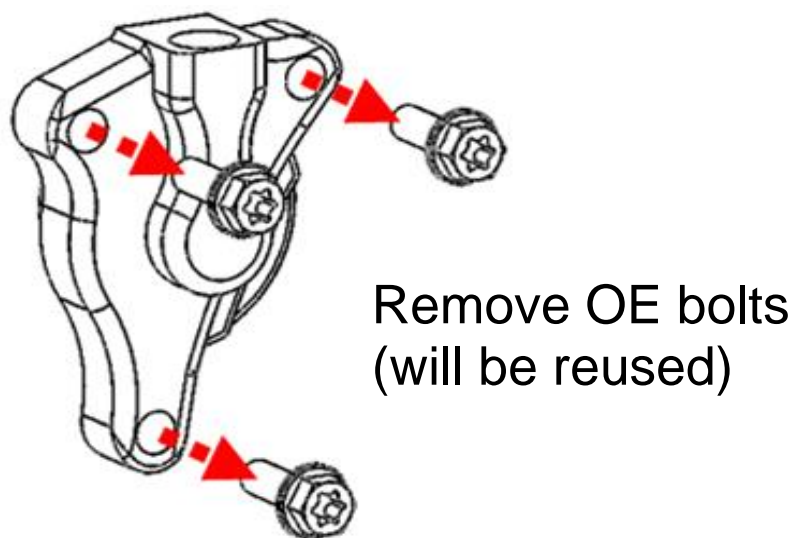

7. Mount the Rekluse slave cylinder to the engine by lightly threading the two shorter OE bolts on the left side until finger tight.

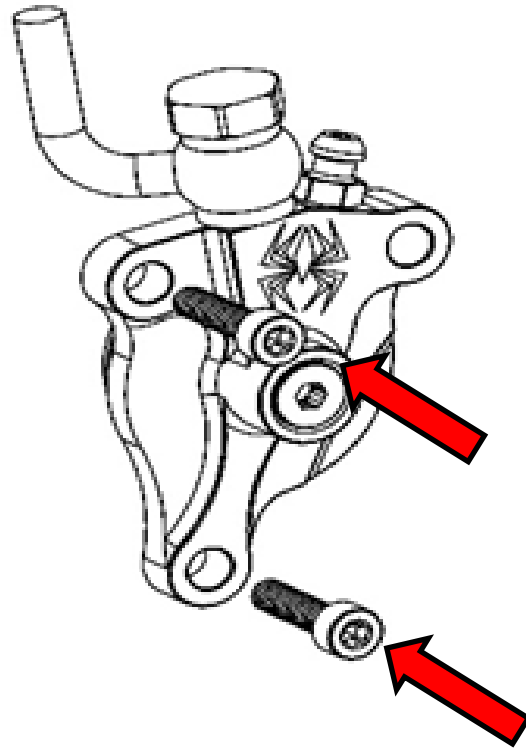

8. Remove the OE chain guard screw sleeve from the plastic chain guard by gently pushing it out the backside.



9. Insert the new provided chain guard screw sleeve into the screw slot, then reattach the chain guard to the slave cylinder using the longer OE screw.



Note: *The Rekluse screw sleeve is slightly taller than the OE screw sleeve. You will need to use the Rekluse screw sleeve to help ensure a good seal to the engine case.*



10. Tighten all the slave cylinder screws to OE specifications.
11. Torque the banjo bolt to 18 ft-lb (25 N-m) per OE specification.

BLEED THE CLUTCH LINE

1. Attach one end of the supplied bleed tube to the bleed port on the slave cylinder, then loop the opposite end into a suitable catch bottle.

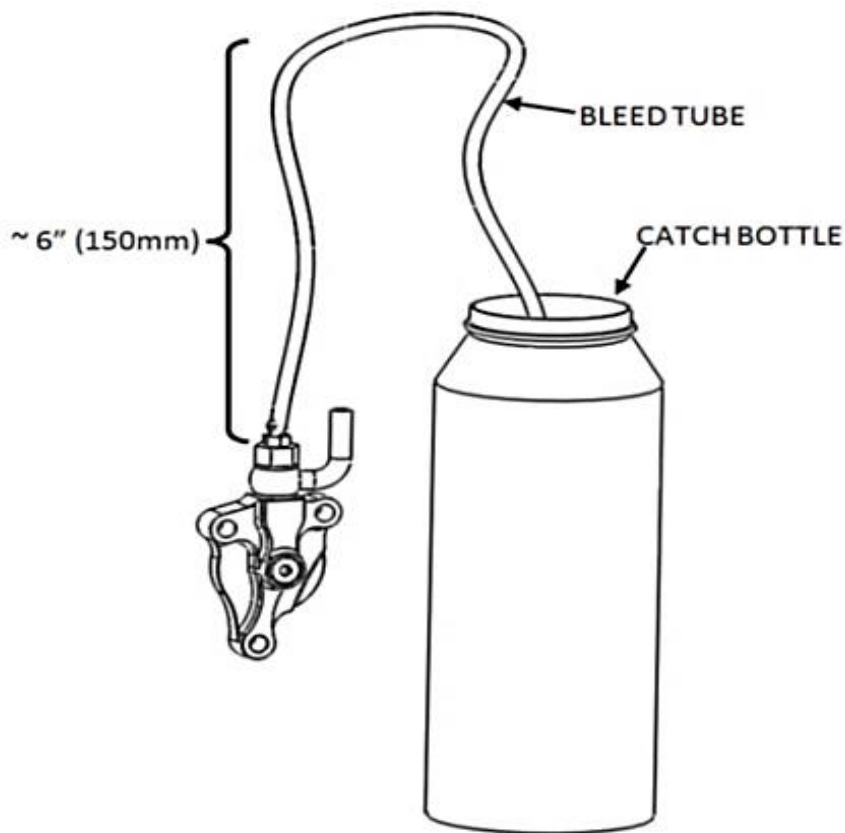

2. On the handlebar, remove the cap and bladder from the clutch master cylinder. Adjust the reservoir so it is level with the ground.

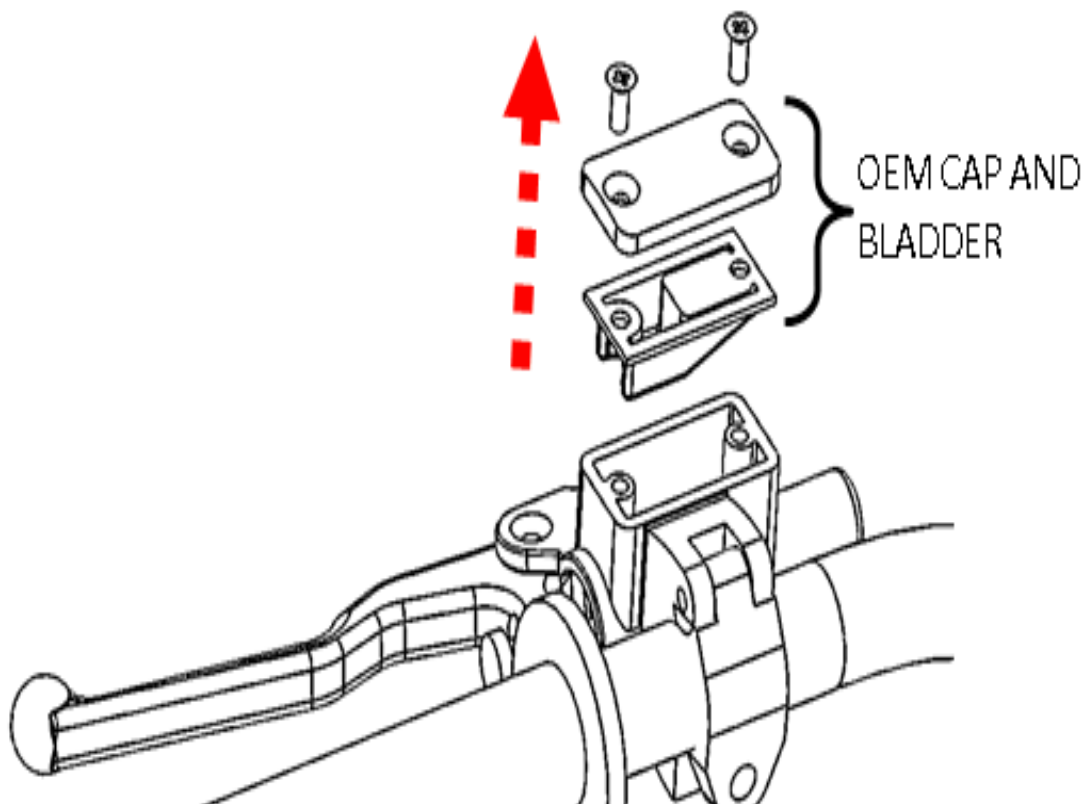

3. Top off the master cylinder with the recommended clutch fluid until it is 75% full.
4. Pump the clutch lever 3 to 5 times, then hold it against the handlebar/grip.

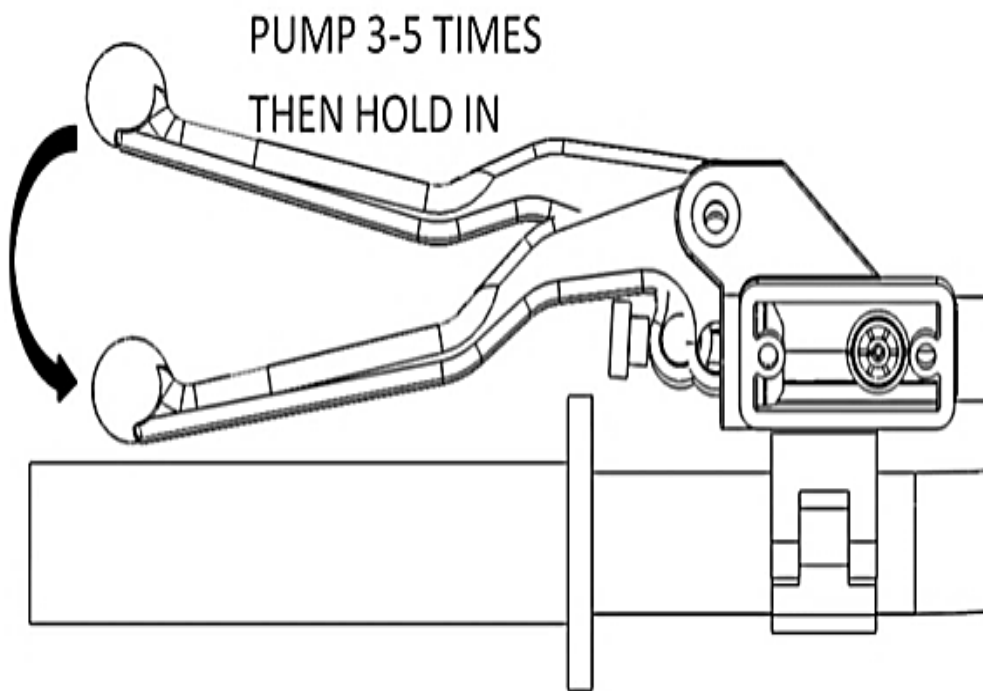

5. While still holding the clutch lever in, use a wrench to open the bleed port. Air and fluid should flow from the bleed tube.

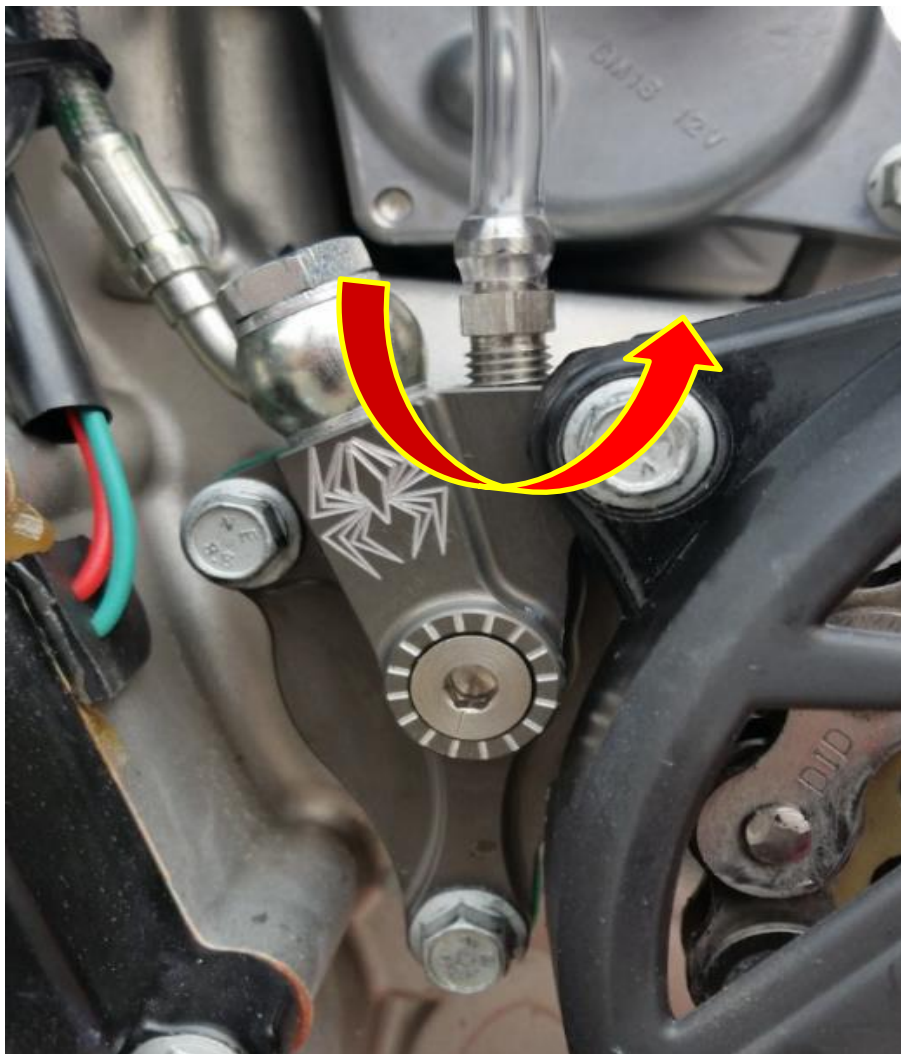

6. Before releasing the clutch lever, tighten the bleed port when the pressure is released from the bleed tube.
7. Slowly release the clutch lever and check the fluid level in the clutch master cylinder. Top off if necessary.

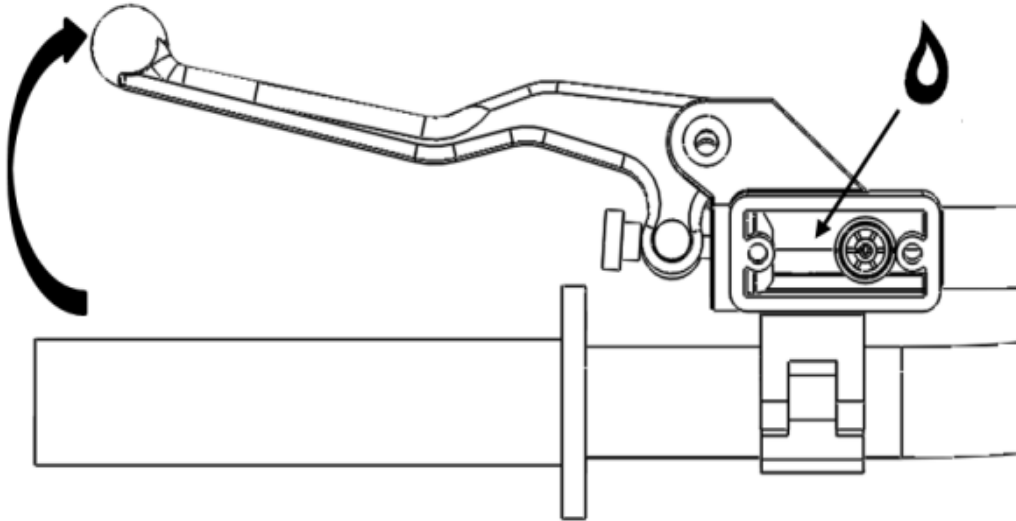

8. Repeat steps 4 - 7 until air no longer comes out of the bleed tube and the clutch feels normal.
9. Check that the clutch master cylinder is 75% full, then replace the cap and bladder.

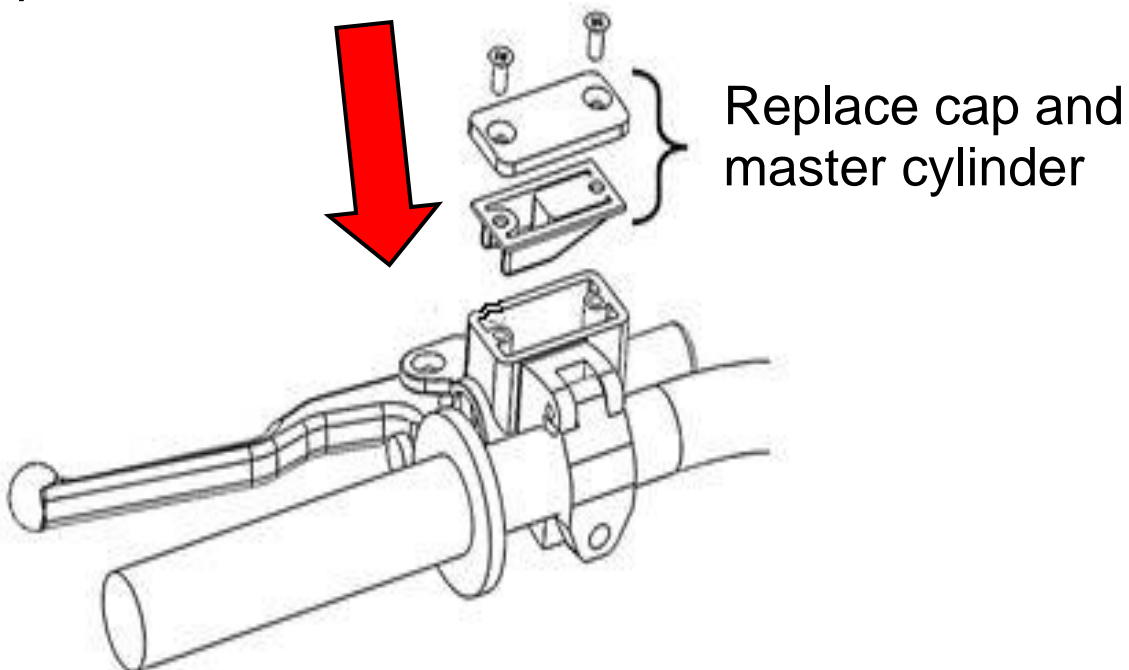

10. Remove the bleed tube from the bleed bolt and remove the bottle.
11. Torque the bleed screw to 150 in-lb (17 Nm) with a socket or the closed end of an 8 mm wrench.

Note: Be sure to use a socket or closed end wrench when torqueing the bleed screw. Using an open-ended wrench can strip the hex screw.

12. Finally, install the rubber dust cap over the bleeder screw.

SET THE INSTALLED GAP AND CHECK FREE PLAY GAIN

It is very important that you understand how to set the installed gap in your new clutch, and be able to verify the installed gap by checking Free Play Gain.

Setup, break-in, and rechecking the installed gap is **CRUCIAL**. Failure to properly maintain your installed gap can result in premature wear or failure of your clutch.

The “installed gap” is the free space in the clutch pack when the EXP disk is disengaged (collapsed). This gap allows the clutch to spin freely until the engagement RPM is reached and the EXP disk expands to close the gap and apply pressure to the pressure plate, which in turn drives the motorcycle forward.

The installed gap is what allows the auto function of the product to perform properly. Use the following steps to set the installed gap and check the Free Play Gain.

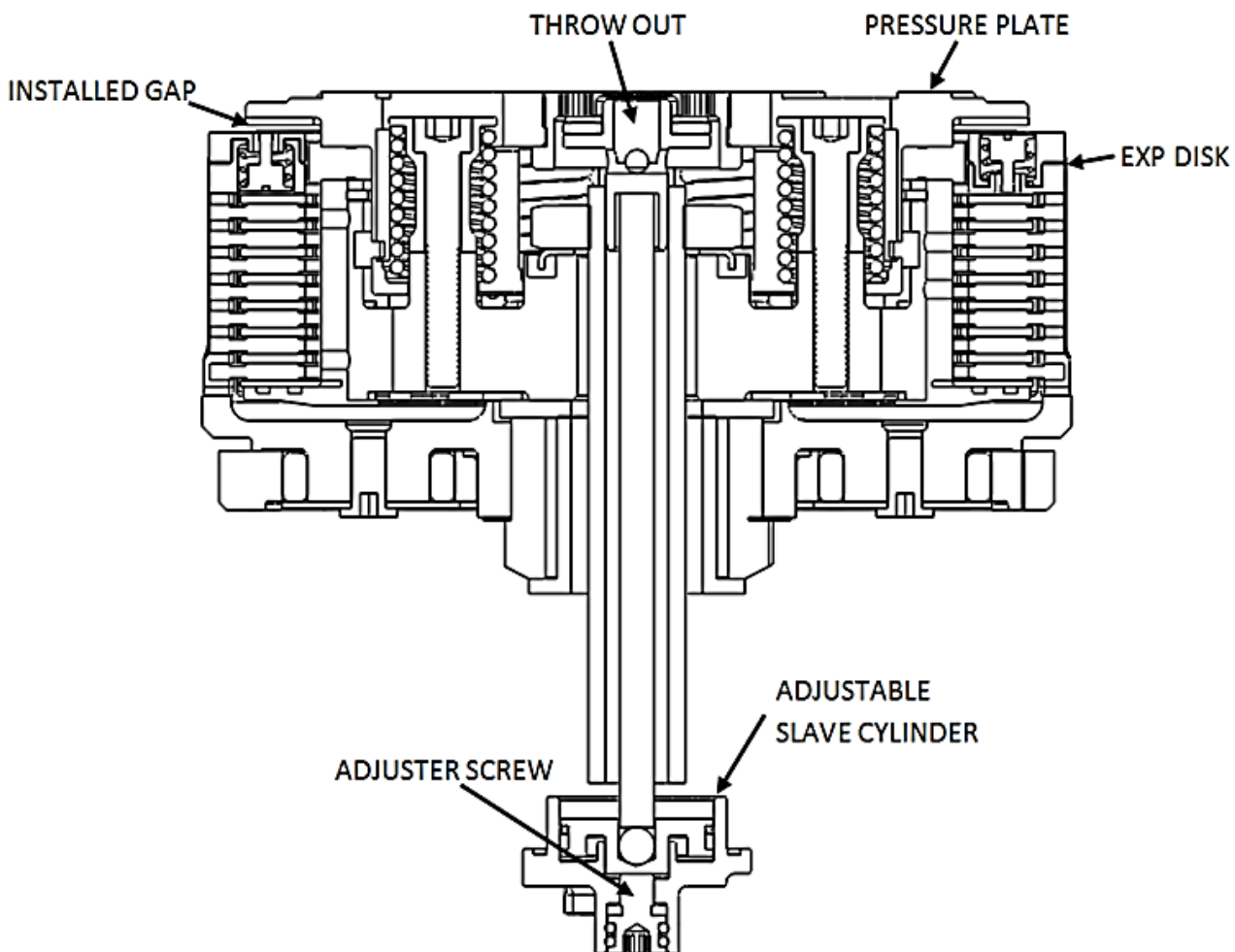

⚠ WARNING

Failure to check and verify Free Play Gain can cause failure or damage to this product. Setting the correct installed gap is critical for clutch performance.

Setting the installed gap and checking Free Play Gain is a 4-step process. It is important to follow each step to ensure that your new clutch functions as designed.

Step 1: Find the starting point

- a) With the bike standing up, locate the adjuster screw in the center of the adjustable slave cylinder.
- b) With the O-ring showing, use a 4 mm Allen wrench to turn the adjuster screw clockwise until it stops under light pressure. This is your “starting point.”

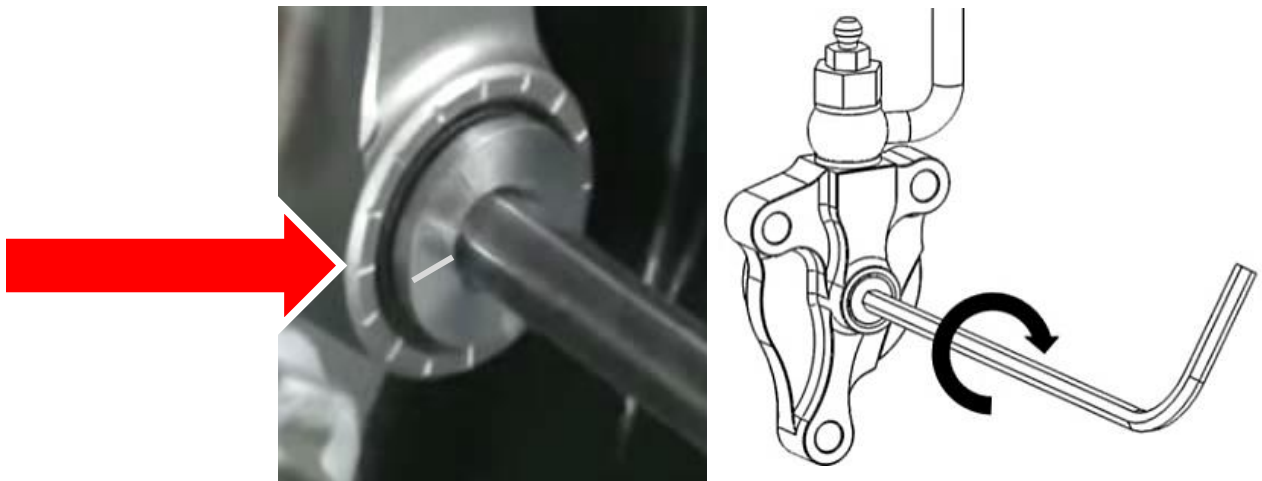

Note: *The resistance you feel is where the throw-out begins to lift the pressure plate. Finding the right starting point may take a few tries, but you will feel a noticeable change in turning effort once you reach that point. Stop when you feel the pressure increase. The “starting point” will change as the clutch pack wears over time.*

- c) Once you have found the starting point, note the position of the Allen wrench using the tick marks on the slave cylinder housing and the small etch mark located on the screw. You will begin here to adjust the installed gap.

- d) Use a 4 mm Allen wrench to turn the adjuster screw clockwise **1 full turn + 2 tick marks** from your starting point. This may NOT be your final setting, but it is a beginning adjustment for finding the correct setting.

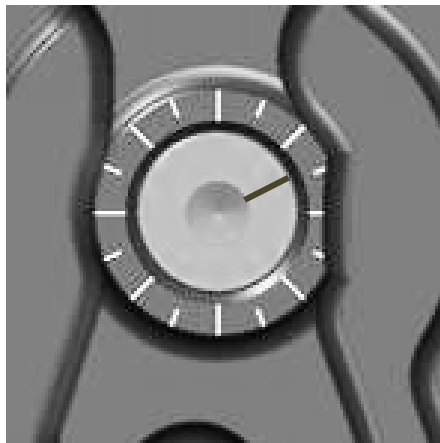

Use the tick marks on the cylinder and the etch mark on the screw to remember the starting point for adjusting the gap.

- e) Continue with Step 2 to check for Free Play Gain.

⚠ CAUTION

Do not ride your bike without the adjusting the installed gap. You will not be able to disengage the clutch until you set the installed gap.

Step 2: Learn how to check Free Play Gain

Feeling Free Play Gain with the beginning adjustment to the slave cylinder aids in learning to recognize Free Play Gain.

If you are familiar with Free Play Gain, check for Free Play Gain then skip to Step 3 -“Break-in the new clutch.”

If Free Play Gain is new to you, follow the instructions below to help you learn this important step. You can also view the video entitled “How to Check Free Play Gain” on our website at www.rekluse.com/support/videos.

Free Play Gain is different from the “normal” free play (slack) you are used to with your stock clutch. With the Rekluse auto clutch, Free Play Gain is the result of the EXP disk expanding and lifting the pressure plate to engage the clutch.

Free Play Gain happens when the engine's RPM increases from idle to above approximately 5,000 RPM and the EXP closes the installed gap. The amount of Free Play Gain you feel in the lever corresponds to the amount the pressure plate has been lifted by the EXP disk expansion.

Checking Free Play Gain allows you to externally monitor the installed gap so you can know when to make an adjustment if the installed gap is too large or too small.

The correct installed gap is verified by observing and feeling the increased free play movement in the clutch lever. This extra movement is called "Free Play Gain."

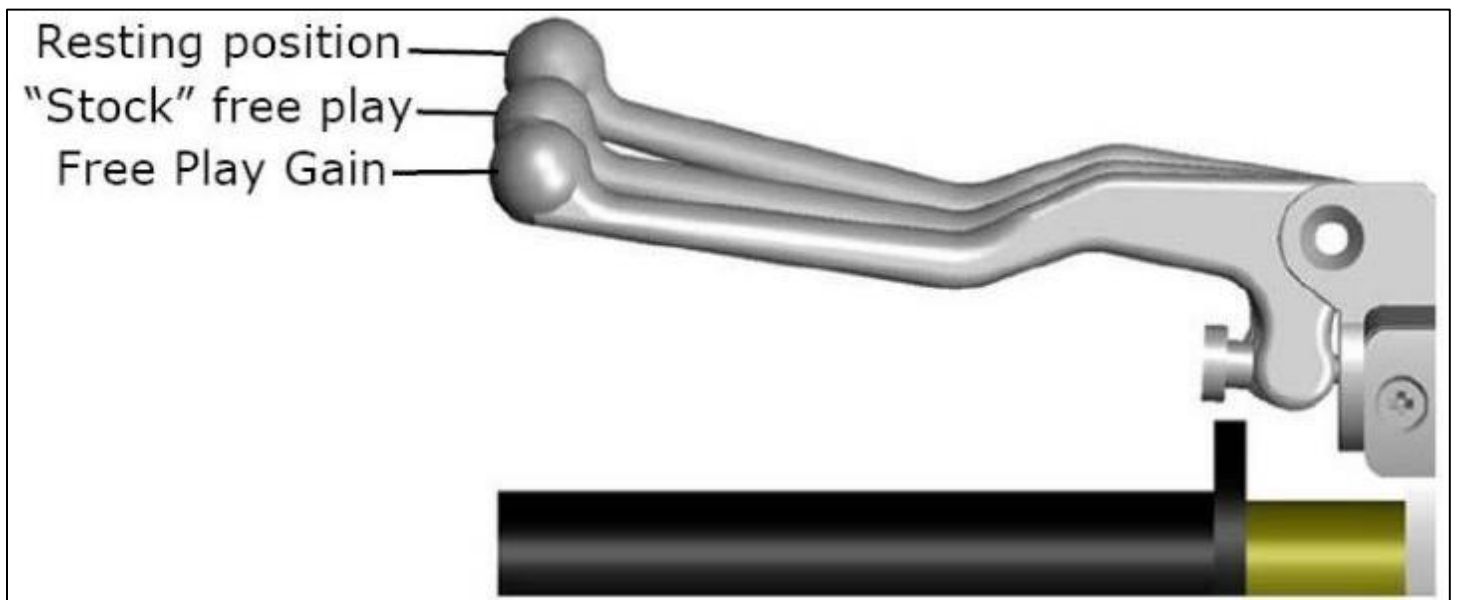

If there is too much Free Play Gain, the installed gap is too small. The bike may drag and stall because it has difficulty disengaging the clutch. It may also be difficult to shift. Too much Free Play Gain will not hurt the clutch, but it will negatively affect clutch performance.

With too little or no Free Play Gain, the installed gap is too large. This means when the EXP is fully expanded it does not lift the pressure plate. The clutch may slip and make the bike seem like it is losing power. The bike may not move forward even though the engine RPM increases as if the clutch lever is slightly pulled. Too little Free Play Gain will cause the clutch system to burn up.

Optimal Free Play Gain yields 1/8" to 1/4" (3 mm-6 mm) of clutch lever movement, measured at the ball end of the lever. This measurement at the lever correlates to achieving the ideal installed gap.

Two Ways to Check for Free Play Gain

The following steps explain **2 ways** to check Free Play Gain. One way uses the rubber band Rekluse includes in the clutch kit, and one uses your hand. You can use either method to check for Free Play Gain.

Rekluse recommends that you begin with the rubber band method first to check for Free Play Gain and then learn the hand method. The rubber band will help you learn how to recognize Free Play Gain until you are comfortable with the hand method. Learning to check Free Play Gain by hand effectively and comfortably can make it easy to check Free Play Gain every time you ride.

The Rubber Band Method

Use the rubber band method for the initial set up. It can also be used before each ride until you feel comfortable checking the Free Play Gain using the hand method.

⚠ WARNING

BEFORE YOU BEGIN, verify that the bike is in NEUTRAL before checking Free Play Gain. Failure to do so may result in the bike lurching forward, and loss of control and/or injury may result.

A Rekluse auto-clutch can make your motorcycle appear to be in neutral when in gear, even when the engine is running and clutch lever released.

Motorcycles equipped with a Rekluse auto-clutch can move suddenly and unexpectedly and cause riders to lose control. To avoid death, serious injury, and/or property damage, always sit on the motorcycle to start it.

- a) Before you begin, place the bike in **NEUTRAL**, start the engine and let it warm up for 2-3 minutes to idle down and warm the engine oil.
- b) Stretch the included rubber band between your thumbs, then place the top end of the rubber band on the outer end of the left handlebar grip.



- c) While holding the top end of the rubber band against the handlebar, stretch the band downward, then loop it through itself.



- d) Pull the band through the loop, then attach it to the outside end of the clutch lever. This will take up the initial free play (slack) and put the lever in a position to detect the Free Play Gain.



- e) While still in **NEUTRAL**, quickly rev the engine between 5,000-7,000 RPM (1/2 to 3/4 throttle), then let it return to idle. Notice the movement in the clutch lever when the engine is revved. This is your Free Play Gain.

Note: *It is very important the motor returns to idle before revving the engine again or Free Play Gain will not be correct.*

- f) When the bike returns to idle, rest your hand across the clutch lever. Rev the engine again to 5,000-7,000 RPM so you can observe the movement while feeling for Free Play Gain with your hand.

The Hand Method

Use the hand method to check Free Play Gain before the start of every ride for optimum performance and longevity of your new clutch.

⚠ WARNING

BEFORE YOU BEGIN, verify that the bike is in **NEUTRAL** before checking Free Play Gain. Failure to do so may result in the bike lurching forward, and loss of control and/or injury may result.

A Rekluse auto-clutch can make your motorcycle appear to be in neutral when in gear, even when the engine is running and clutch lever released.

Motorcycles equipped with a Rekluse auto-clutch can move suddenly and unexpectedly and cause riders to lose control. To avoid death, serious injury, and/or property damage, always sit on the motorcycle to start it.

- a) Before you begin, place the bike in **NEUTRAL**, start the engine and let it warm up for 2-3 minutes to idle down and warm up the engine oil.
- b) With the bike at idle, apply enough pressure to the clutch lever to take up the initial free play (slack) in the clutch lever.

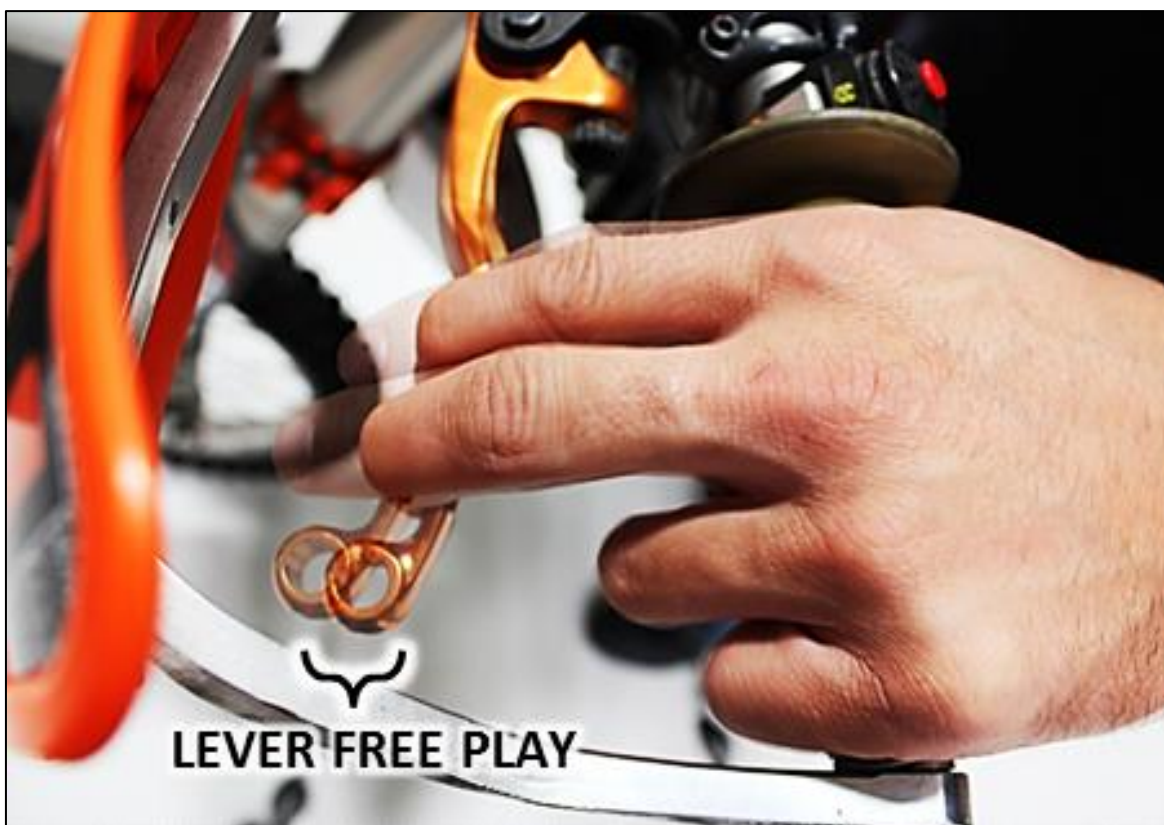

- c) While still in **NEUTRAL**, continue to apply light pressure and quickly rev the engine between 5,000-7,000 RPM (1/2 to 3/4 throttle), then let it return to idle. Notice the movement in the clutch lever when the engine is revved. This is your Free Play Gain.

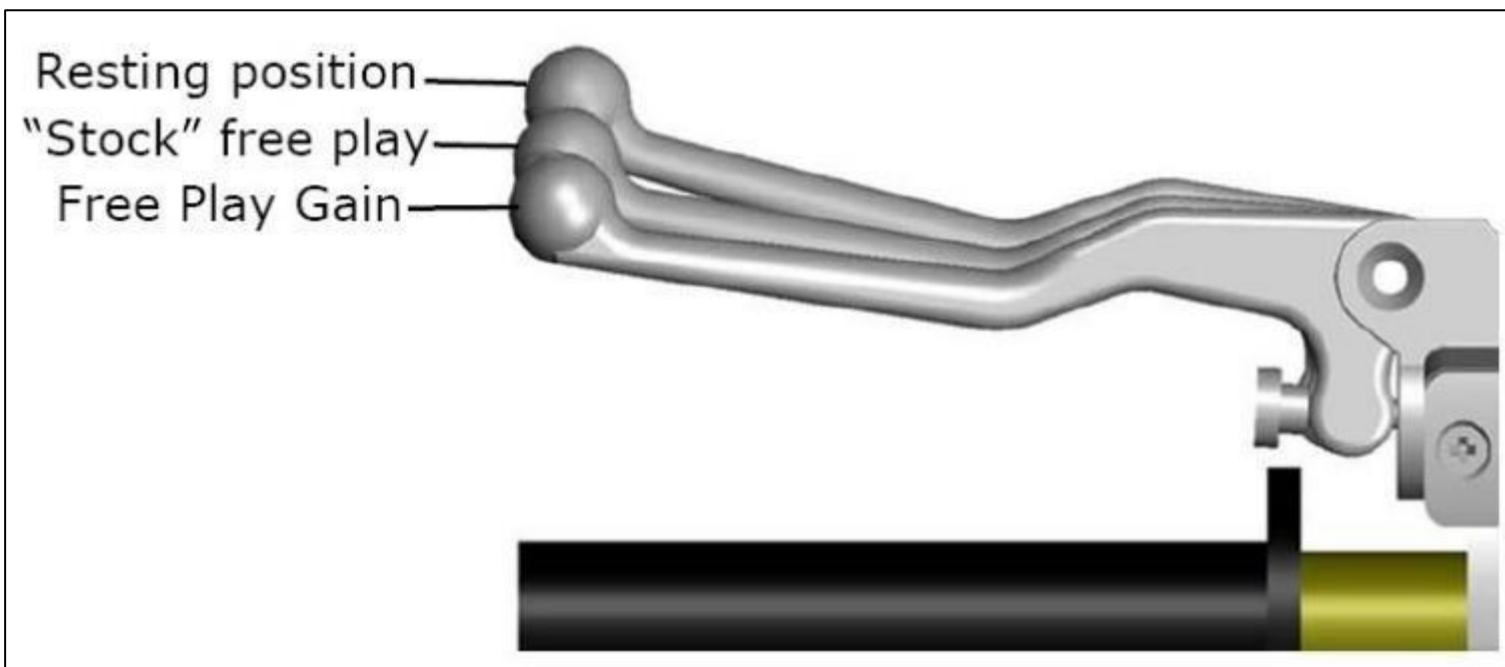

- d) When the bike returns to idle, rev the engine between 5,000-7,000 RPM a second time to feel the Free Play Gain again.
- e) Continue with Step 3 to break-in the new clutch.

Step 3: Break-in the new clutch

Once you install your new clutch, it is important to break it in. A series of roll-on starts are used to break in the clutch. Follow these procedures for breaking in your clutch and any time new friction disks, EXP bases, Teflon pads, or wedges are installed.

▲ WARNING

Failure to follow the break-in procedure and oil screen inspection process could cause motor oil delivery failure, which can result in motor failure, serious injury, or death.

Break-in Procedure	Number of times
<p>Rev Cycles:</p> <ol style="list-style-type: none"> Place the bike in NEUTRAL. With your hand off the clutch lever, rev the engine 10 times, being sure to let it return to idle between each rev cycle. 	<p>① N ② ③ ④ ⑤</p> <p>10 rev cycles</p>
<ol style="list-style-type: none"> With the engine still running, pull in the clutch lever, then click the bike into 1st gear. Slowly release the clutch lever. The bike should stay in place or have a slight amount of forward creep. With the bike idling in first gear, slowly apply throttle to begin moving. Without using the clutch lever, accelerate moderately to approximately 5,000 RPM to fully lock up the clutch and come to a complete stop. Repeat 10 times. <p>Note: <i>If the engine wants to stall or the creep is excessive, the idle may be too high or the installed gap may be too small. Make necessary adjustments before proceeding.</i></p>	<p>① N ② ③ ④ ⑤</p> <p>10 roll-on starts</p> <p>Continued on next page </p>

6. Without using the clutch lever, start in 2nd gear, then accelerate moderately to approximately 5,000 RPM and come to a complete stop. Repeat 10 times.



10 roll-on starts

7. Place the bike in **NEUTRAL** and recheck Free Play Gain.

8. Continue to step 4 to adjust the installed gap until the Free Play Gain of the clutch lever is 1/8" to 1/4" (3 mm-6 mm).



Recheck Free Play Gain and adjust the installed gap

Note: *Your clutch pack will expand with heat, so final adjustment to Free Play Gain should be made when the bike is warm. Remember not to ride without sufficient Free Play Gain.*

CAUTION

Do not perform 3rd gear starts with this product. Starting in 3rd gear will burn up the clutch and decrease the performance of this product in a short amount of time.

Step 4: Adjust the installed gap and Recheck Free Play Gain

Once you have learned how to check Free Play Gain, you need to finish adjusting the installed gap, then recheck the Free Play Gain until the clutch lever moves only 1/8" to 1/4" (3 mm-6 mm). The gap is adjusted by turning the slave cylinder screw.

- a) With the bike running and in **NEUTRAL**, locate the adjuster screw in the center of the adjustable slave cylinder.
- b) Use a 4 mm Allen wrench to turn the adjuster screw clockwise 1 tick mark from the last setting, then recheck Free Play Gain.



Tick marks are located on the slave cylinder, and an etch mark is on the screw. If you need to re-position the Allen wrench, you can use these marks for reference.

- c) Continue to adjust the slave cylinder 1 tick mark at a time until optimal Free Play Gain is achieved.
- d) Refer to the following pictures and chart in the next section for additional adjustment information.
- e) The Free Play Gain will change as the clutch pack wears over time.
- f) Checking the Free Play Gain is easy and indicates when the install gap needs adjusting.

FREE PLAY GAIN ADJUSTMENTS

Make each adjustment in small increments - one tick mark at a time. After each adjustment, recheck Free Play Gain until you achieve the optimal 1/8" to 1/4" (3 mm-6 mm) of clutch lever movement.



Symptom	Reason	Solution
<ul style="list-style-type: none"> • Clutch lever moves in too far (too much Free Play Gain) • Clutch has excessive drag or stalls • It is difficult to fully override the clutch with the lever 	<p>Installed gap is too small</p>	<p>Turn the adjuster screw clockwise 1-2 marks to increase the installed gap and decrease Free Play Gain. Recheck Free Play Gain.</p>
<ul style="list-style-type: none"> • Clutch lever only moves slightly or does not move at all (too little Free Play Gain) • Clutch slips • Bike seems to lose power 	<p>Installed gap is too large</p>	<p>Turn the adjuster screw counterclockwise 1-2 marks to reduce the installed gap and increase Free Play Gain. Recheck Free Play Gain.</p>

LEVER SAFETY STRAPS

Your kit includes a Velcro strap to be used to secure either the clutch lever or the front brake lever when the bike is parked.

This strap is intended to reduce the risk of injury or damage that may occur from the bike rolling or launching unexpectedly with or without a rider. Use the lever safety strap every time you park or leave the bike. **Refer to the Safety Information sheet for more information.**

1. Pull the lever tight against the handlebar.
2. Wrap the Velcro safety strap around the lever and handlebar, pull it tight, then fasten it.



Clutch lever strap: Use to prevent unwanted launching



Brake lever strap: Use as a parking brake.

MAINTENANCE

To keep your clutch performing at its best, perform regular maintenance on your bike and clutch.

- Keep up with regular oil changes as per the bike manufacturer's recommendations. Clutch performance and longevity depend on oil quality. Oil recommendations can also be viewed under Tech Tips on our website at www.rekluse.com/support/videos/atv-mc-support-videos.
- Inspect all of your clutch parts for signs of wear or excessive heat, and replace components as necessary. Clutch wear is dependent on the riders use.

Maintenance Protocol	Maintenance Intervals
Check and verify Free Play Gain	Every ride
Inspect all clutch parts for excessive wear or heat. Replace as needed.	Refer to OE service manual
Change oil, inspect and clean oil screen	Refer to OE service manual

- Inspect the dampers, and replace them if you feel any movement between the two hubs. Refer to the section on inspecting the dampers for more information.
- Maintain adequate Free Play Gain. Check before every ride and adjust if necessary.
- Replace friction disks if the disks are glazed and/or burnt.
- Measuring the clutch pack and/or the EXP disk can help determine if the components need replacing.
- Repeat the break-in procedure anytime you replace the EXP bases, Teflon pads, EXP wedges, or frictions disks. Always soak friction disks or EXP bases in oil for at least 5 minutes before installing.
- Replace the drive plates if they show signs of excessive heat.

Disk inspection examples

When inspecting the clutch pack, the following pictures can be used as a reference. **These are best viewed in color by viewing this install document on our website at www.rekluse.com/support.**

Drive Plates – If the clutch pack is getting high amounts of heat, purple, blue, or black color can be seen on the drive plate teeth. See pictures below. Not all drive plates look the same and may look different than pictured.



Normal Heat

High Heat
(Blue)

Excessive Heat
(Black)

Friction Disks – Due to the dark color of the friction material, the friction disks will appear almost black as soon as they are put in oil. During inspection, look for glazing of the friction material. Glazing will appear shiny and feel like glass, even after oil is cleaned from the friction disk. Not all friction disks look the same and may look different than pictured.



Normal
Friction



Glazed
Friction

TROUBLESHOOTING

Performance issues

If you find yourself adjusting the slave cylinder to fix Free Play Gain or drag, the clutch disks might be worn. Excessive heat or clutch slip can cause premature clutch failure as well. Once extreme temperatures are reached, irreversible damage will occur.

- Inspect all of your clutch parts for signs of wear or excessive heat, and replace components as necessary. Clutch wear is dependent on the riders use.
- Measuring the clutch pack and/or the EXP disk can help determine if the components need replacing.

Clutch noise

Although it is harmless, some bike models may have “squeal” or “chatter” coming from the clutch at low RPM as it engages. Clutch squeal is caused by the clutch components vibrating as the clutch engages and can become more audible as the clutch gets hot. Adjusting the installed gap will NOT affect clutch squeal or chatter.

For bike models that have clutch squeal or chatter here are some recommendations to reduce or eliminate it:

- Change the oil: For optimal clutch performance Rekluse recommends using fresh, clean oil that **meets JASO-MA** oil rating requirements. Dirty or old oil can make the clutch more likely to squeal or chatter.

EXP TUNING OPTIONS

Adjusting the engine idle speed to match your engagement setting is important and greatly affects the overall feel of how the EXP disk engages.

To prevent freewheeling and maximize engine braking, set the idle so there is a slight amount of drag while the bike is idling in gear and warmed up. The idle should not be so high as to move the bike forward in gear with the throttle closed. However, with a small opening of the throttle the bike should move forward.

You can tune the engagement RPM of the EXP disk by changing the spring configuration. The EXP disk comes set with the recommended “**Medium**” setting from Rekluse. Use the following steps to change the springs. It is **NOT necessary** to disassemble the EXP halves to change springs!

Note: ** *It has been found that some Beta 4-Stroke models have a high “hanging idle” which can make it more difficult to tune the EXP disk. Additional spring settings have been included to offer further tuning options if needed. The higher the engine idle, the higher the EXP engagement setting will need to be to compensate. Refer to the **Setup Sheet** for EXP settings.*

Changing the springs

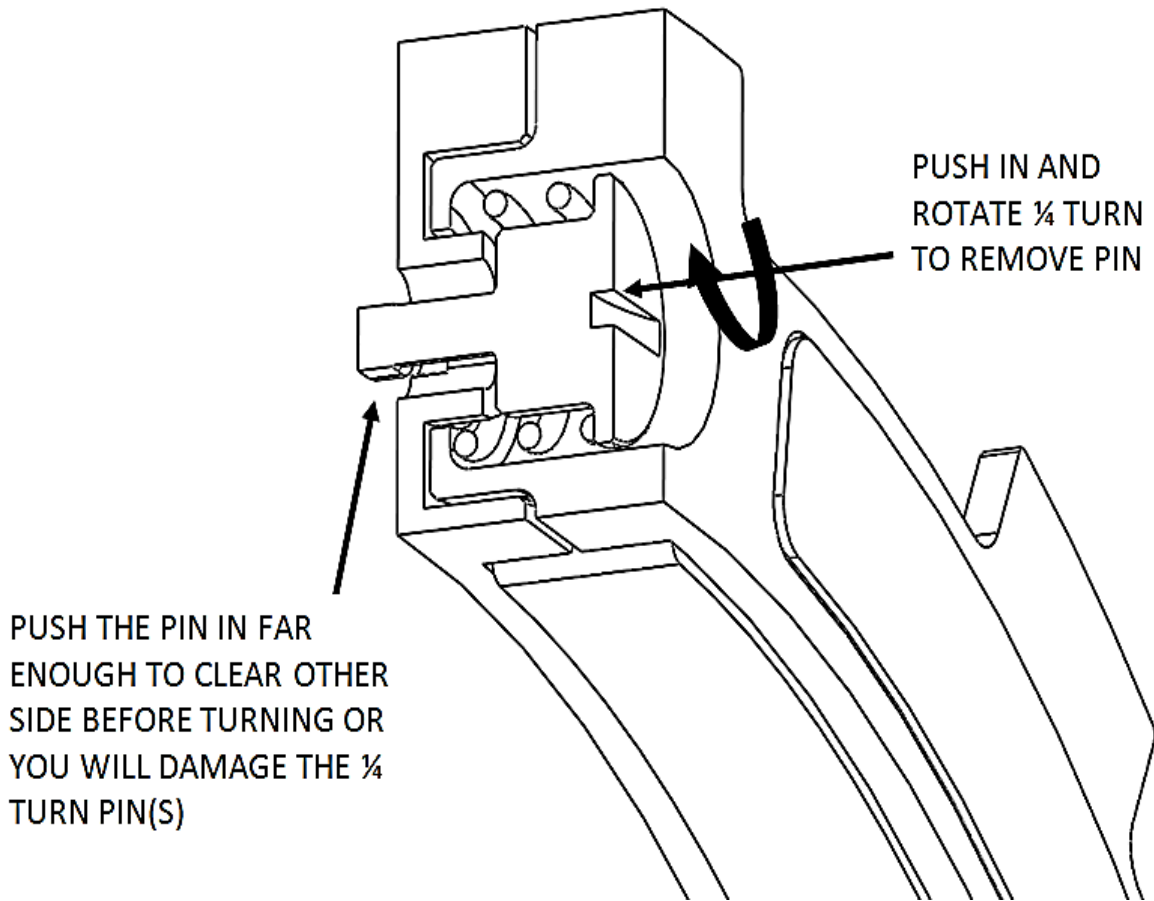

1. Using a flat-blade screwdriver, push the 1/4 turn pin in far enough to clear the opposite side of the EXP to unlock the pin.
2. With the pin still pushed past the base, turn 90° to remove the pin and spring.
3. Remove the remaining 2 pins and springs from the same side of the EXP base.

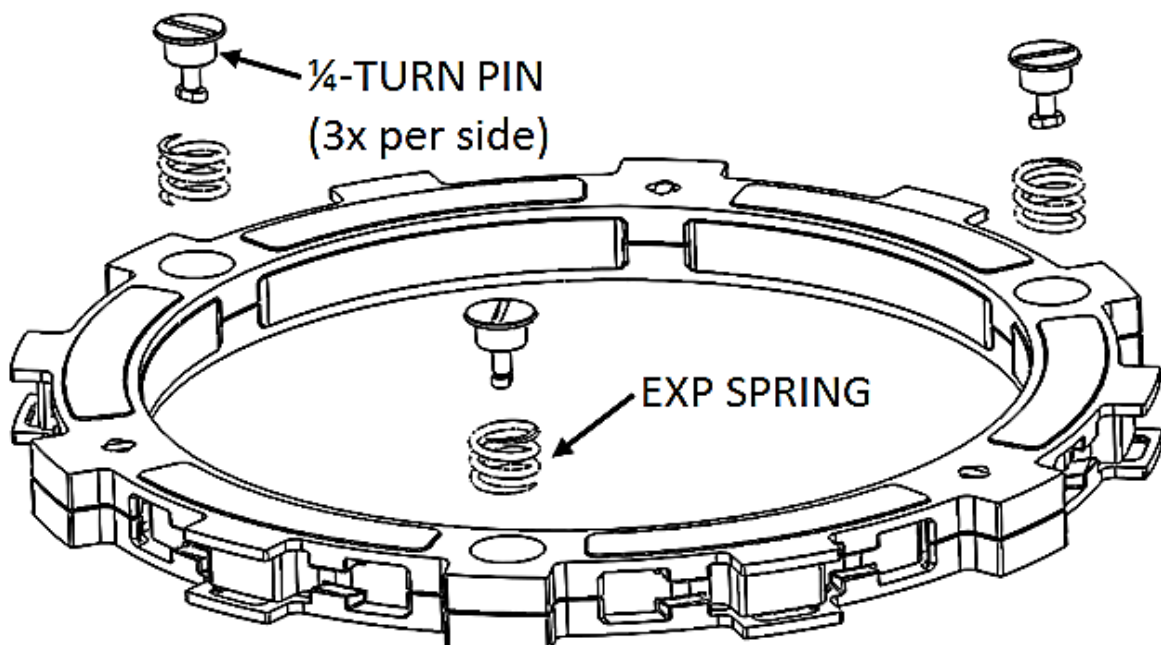

4. Drop a new spring into the spring slot on the base, then add the $\frac{1}{4}$ turn pin.
5. Push the turn pin in far enough to clear the base, then turn 90° and release the pin. The pin should sit almost flush with the EXP base.
6. Flip the EXP friction disk over, and repeat on the other side depending on engagement preference.
7. If you need to disassemble the EXP disk, you can watch the video on our website under Tech Tips at www.rekluse.com/support/videos/atv-mc-support-videos.

Note: To maintain even pressure, when using two different color spring sets, install one set of 3 on one side of the EXP and the remaining set of 3 on the other side.

CAUTION

If you disassemble the EXP, the Teflon pads may fall out or be stuck to the ramp surfaces of the EXP bases. Take care to ensure all pads are correctly placed into wedge pockets using gentle pressure to avoid damage to the pad surfaces before reassembling the EXP. Properly seated pads will be secured in place once the EXP is reassembled. Operating the clutch without the pads in place will cause part damage or failure.

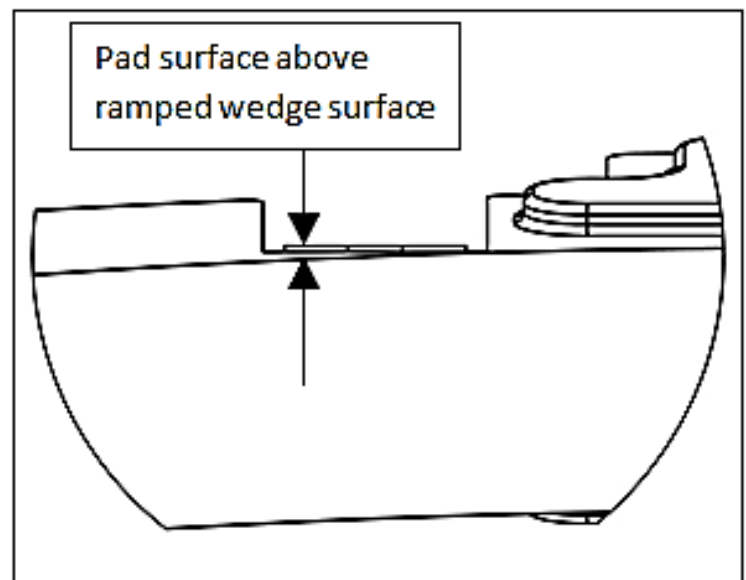
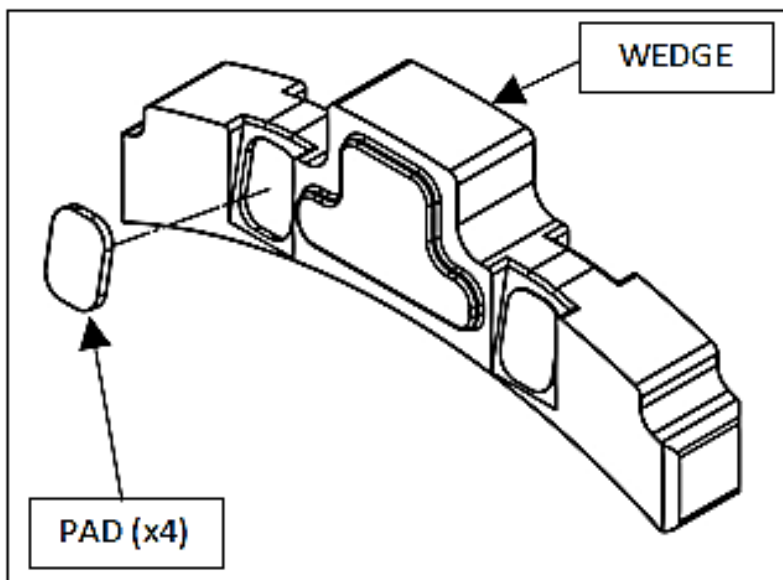

BUMP-STARTING

If your bike needs to be bump-started due to a dead battery or any other reason, follow the steps below to quickly bump-start your bike.

1. Turn the adjustable slave cylinder counterclockwise to collapse the gap until no resistance is felt.
2. Bump start the bike. The clutch will function like a manual clutch at this point, but the clutch will not be fully over-ridable at high RPMs.
3. Once the bike is started, readjust the installed gap.

NEED ADDITIONAL HELP?

Website

www.rekluse.com/support

Frequently asked questions

www.rekluse.com/faq

Support Videos

www.rekluse.com/support/videos

Phone

(208) 426-0659

Technical Support

Contact Technical Support for questions related to product installation, tuning, and performance.

Hours:

Monday thru Friday: 8:00 a.m. - 5:00 p.m.

Mountain Time zone

Email: tech@rekluse.com

Customer Service

Contact Customer Service for additional product information, orders, and returns.

Hours:

Monday thru Friday: 8:00 a.m. - 5:00 p.m.

Mountain Time zone

Email: customerservice@rekluse.com



Use the following instructions to replace the Teflon pads in the EXP wedges.

EXP DISASSEMBLY

1. Use a flathead screwdriver to remove all quarter-turn pins and EXP springs (three per side). These will be reused.

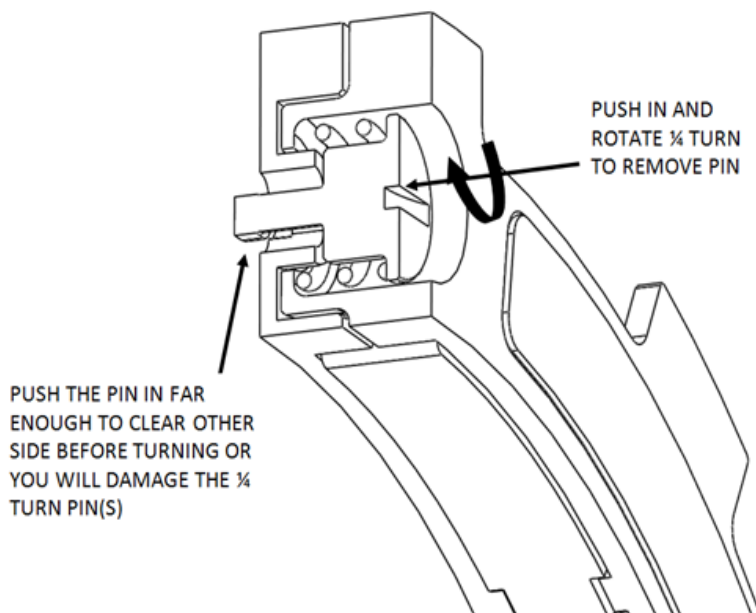

2. Separate bases and remove wedges. In a used EXP, be aware that wedge pads may stick to base ramps from oil tension. Just remove the stuck pads from the EXP base before reinstalling the wedges.

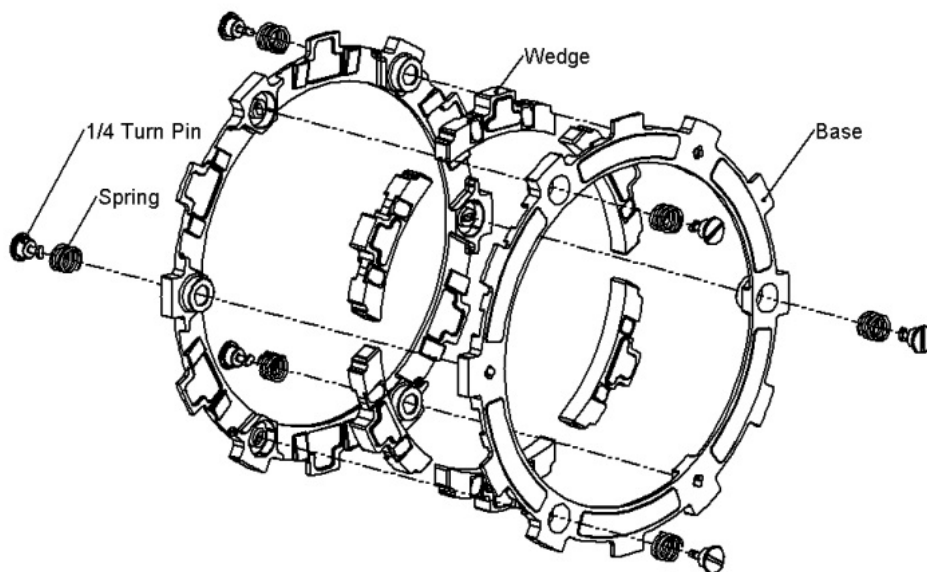

3. Inspect the EXP bases. Do not reinstall the wedges into worn bases. See the video at <https://rekluse.com/support/videos> for instructions on how to inspect the EXP disk.

REPLACE TEFLON PADS

1. Place the wedges onto a workbench.
2. Use the tip of a razor blade or knife to push into the center of the old pad, then pop the pad out.

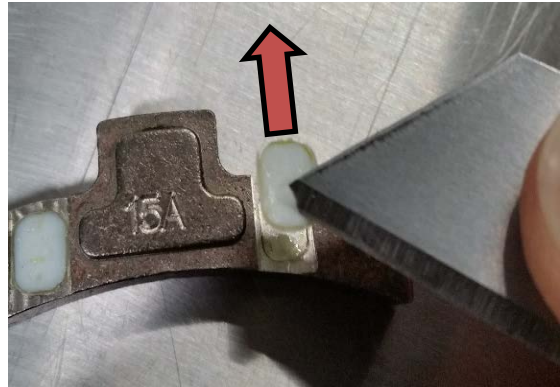

3. Place the new pad over the wedge pocket in the wedge.

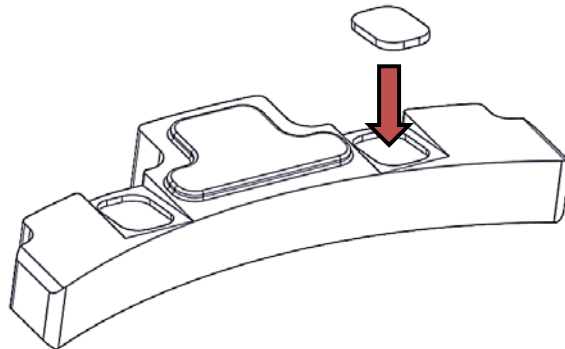

4. Use the flat part of a flat blade screwdriver or similar tool to press the Teflon pad into the wedge. You may need to turn the wedge around and press on the opposite side to get the pad to fully seat.



⚠ CAUTION

Do not press directly in the center of the pad with the tip of the screwdriver or any sharp object. This will make an indent in the pad and the wedge will not function properly.

5. Replace the other 3 pads in the same way, then finish replacing the pads on all the remaining wedges. ***When installed correctly, the pads will stick slightly above the wedge pocket.***
 6. Reinstall the wedges into the EXP disk, then reinstall the EXP springs and quarter-turn pins.
- NOTE:** *The EXP disk might have a small gap down the center line once reassembled. The gap may not be even or symmetrical. This gap will close during the break-in procedure.*
7. Push each wedge out from the inside of the EXP disk to see if they move in and out. The wedges should move smoothly and spring back into place without catching.

BREAK IN THE NEW PADS

1. Once the EXP is reinstalled in the clutch, set the installed gap.
2. Break in the new pads:
 - a. Shift the bike into Neutral.
 - b. With your hand off the clutch lever, rev the engine 10-15 times, being sure to let it return to idle between each rev cycle.
3. Check for Free Play Gain. Readjust the installed gap until the Free Play Gain is about 1/8" (3 mm).

NEED HELP?

Visit our website at www.rekluse.com/support or call us at (208) 426-0659.

Use the following instructions to replace the Teflon pads in the EXP wedges.

EXP DISASSEMBLY

1. Use a flathead screwdriver to remove all quarter-turn pins and EXP springs (three per side). These will be reused.

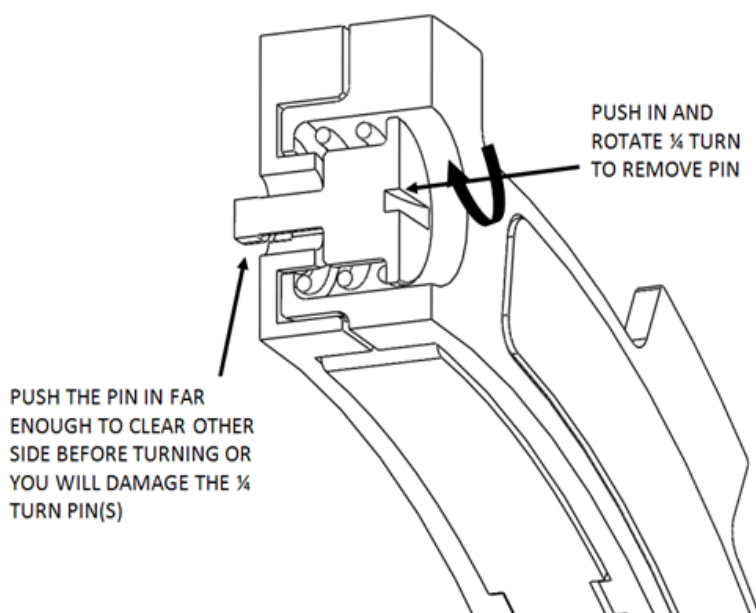

2. Separate bases and remove wedges. In a used EXP, be aware that wedge pads may stick to base ramps from oil tension. Just remove the stuck pads from the EXP base before reinstalling the wedges.

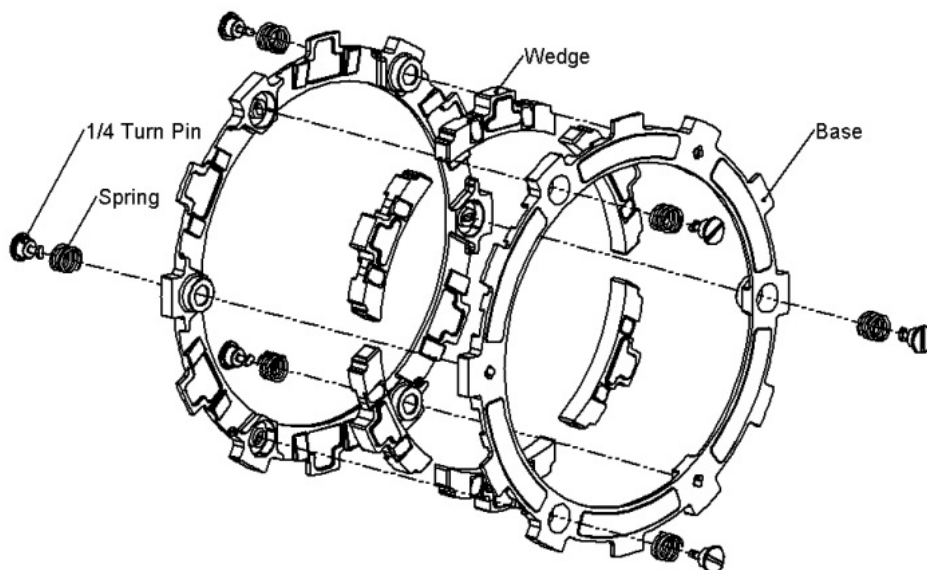

3. Inspect the EXP bases. Do not reinstall the wedges into worn bases. See the video at <https://rekluse.com/support/videos> for instructions on how to inspect the EXP disk.

REPLACE TEFLON PADS

1. Place the wedges onto a workbench.
2. Use the tip of a razor blade or knife to push into the center of the old pad, then pop the pad out.

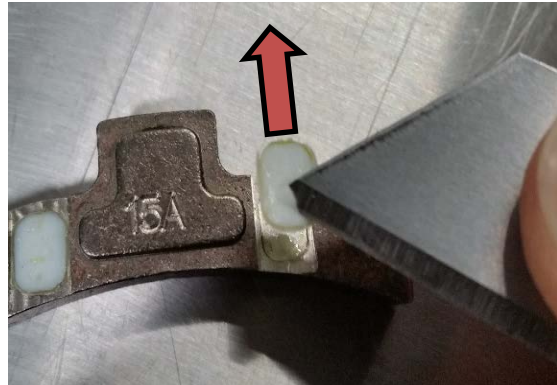

3. Place the new pad over the wedge pocket in the wedge.

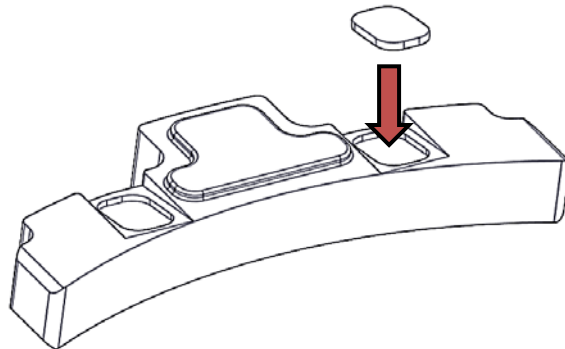

4. Use the flat part of a flat blade screwdriver or similar tool to press the Teflon pad into the wedge. You may need to turn the wedge around and press on the opposite side to get the pad to fully seat.



⚠ CAUTION

Do not press directly in the center of the pad with the tip of the screwdriver or any sharp object. This will make an indent in the pad and the wedge will not function properly.

5. Replace the other 3 pads in the same way, then finish replacing the pads on all the remaining wedges. ***When installed correctly, the pads will stick slightly above the wedge pocket.***
 6. Reinstall the wedges into the EXP disk, then reinstall the EXP springs and quarter-turn pins.
- NOTE:** *The EXP disk might have a small gap down the center line once reassembled. The gap may not be even or symmetrical. This gap will close during the break-in procedure.*
7. Push each wedge out from the inside of the EXP disk to see if they move in and out. The wedges should move smoothly and spring back into place without catching.

BREAK IN THE NEW PADS

1. Once the EXP is reinstalled in the clutch, set the installed gap.
2. Break in the new pads:
 - a. Shift the bike into Neutral.
 - b. With your hand off the clutch lever, rev the engine 10-15 times, being sure to let it return to idle between each rev cycle.
3. Check for Free Play Gain. Readjust the installed gap until the Free Play Gain is about 1/8" (3 mm).

NEED HELP?

Visit our website at www.rekluse.com/support or call us at (208) 426-0659.

198-7902122 SETUP SHEET

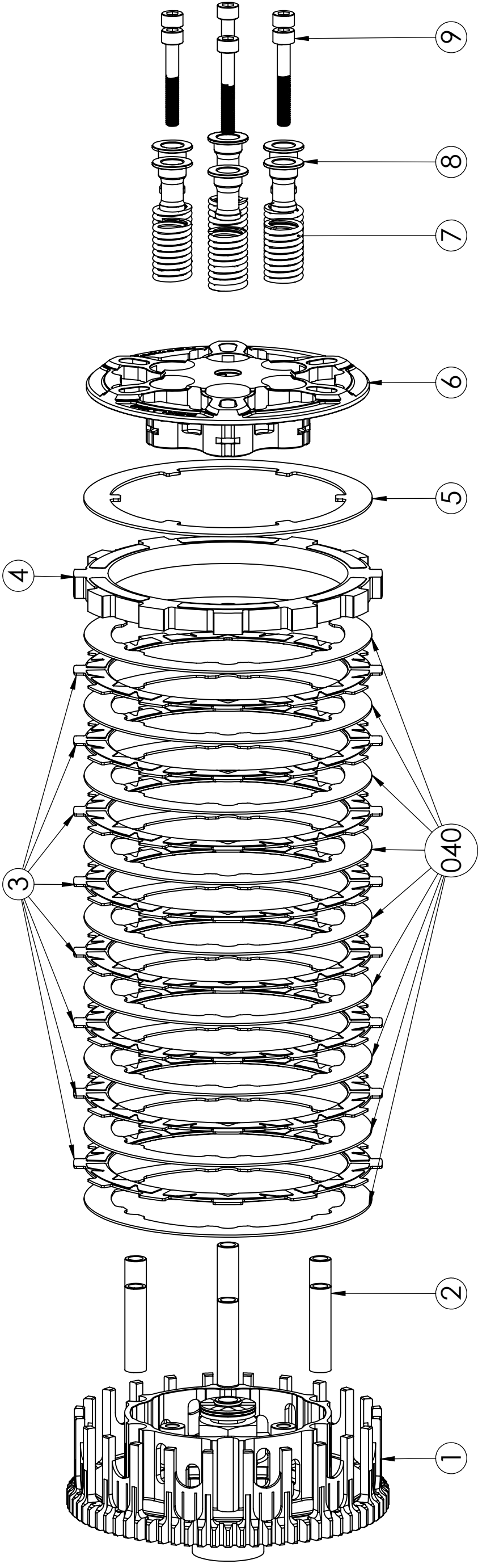

EXP TUNING OPTIONS	
ENGAGEMENT RPM SETTING	SPRING CONFIGURATION
LOW	2-STROKE MODELS 6 SILVER 3 RED 3 BLUE
MEDIUM*	3 SILVER 3 RED 6 BLUE
HIGH	6 RED 3 BLUE 3 GOLD
SUPER-HIGH**	N/A 6 GOLD
ULTRA-HIGH**	N/A 3 GOLD 3 GREEN

***MEDIUM SETTING IS PREINSTALLED IN THE EXP DISK**
**** Some Beta 4-Stroke models have a high "hanging idle" which can make it more difficult to tune the EXP disk. Additional spring settings have been included to offer further tuning options if needed. The higher the engine idle, the higher the EXP engagement setting will need to be to compensate.**

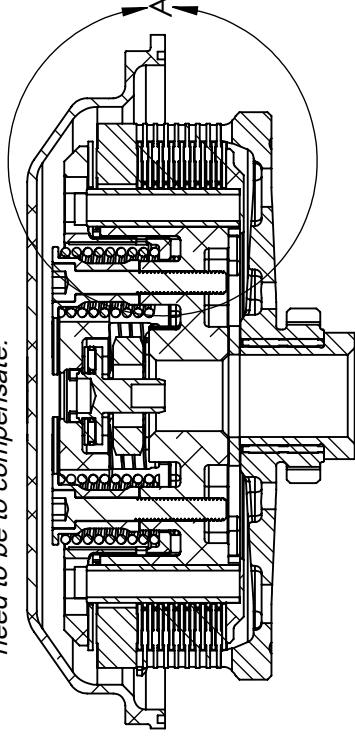

DETAIL A
SCALE 1 : 1

SERVICE LIMITS

COMPONENT	STANDARD	SERVICE LIMIT
TORQDRIVE FRICTION	.068-.072in 1.73-1.83mm	.065in 1.65mm
EXP	.426-.446in 10.8-11.3mm	.416in 10.6mm

CLUTCH PACK THICKNESS

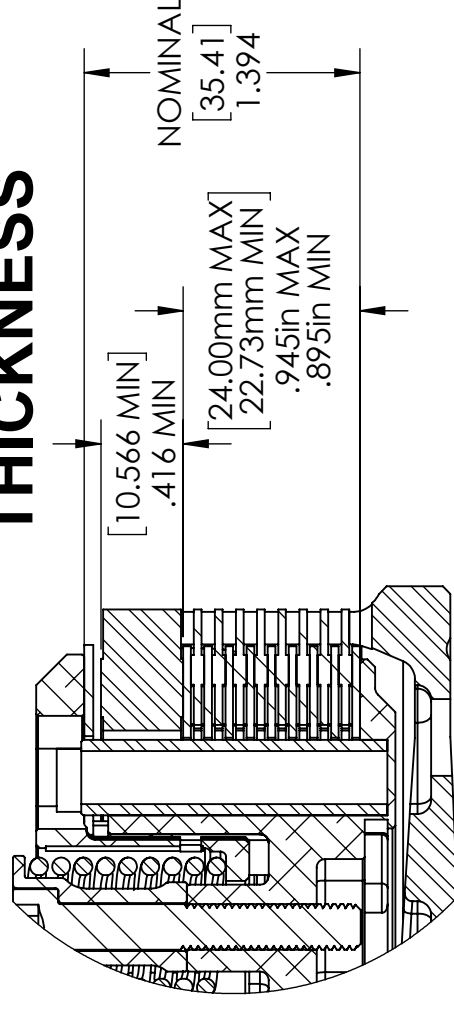

COMPONENTS

ITEM NO.	DESCRIPTION	QTY.
1	OE BASKET	1
2	OE DRIVE PIN	6
3	TorqDrive Friction 0.070" (1.78mm)	8
4	EXP DISK	1
5	PRESSURE PLATE LINING PLATE	1
6	PRESSURE PLATE	1
7	PRESSURE PLATE SPRINGS	6
8	SCREW SLEEVE	6
9	M6X40 SOCKET CAP SCREW	6
040	DRIVE PLATE 0.040" (1mm)	9

CLUTCH PACK REPLACEMENT NOTES

RadiusCX Clutch Product – Hydraulic, with Steel Basket

INSTALLATION GUIDE

The installation guide for the full RadiusCX clutch product has been provided with this clutch pack replacement kit. You will use it to install, tune, and maintain your RadiusCX clutch product.

RESETTING THE INSTALLED GAP

Because your new clutch pack will be slightly different in thickness than the used clutch pack, perform the “SETTING THE INSTALLED GAP” and “CHECKING FREE PLAY GAIN” sections of the RadiusCX installation guide after installing the new clutch plates.

BREAK-IN

Follow the break-in procedure after the new clutch plates are installed in your bike. Do this anytime the clutch plates, EXP disk, or wedge pads are replaced.

INCLUDED PARTS

Item #	Item Type	Qty
67	Steel Drive Plate	9
69	TorqDrive [®] Friction Disk	8

