

SETUP SHEET 198-7101001

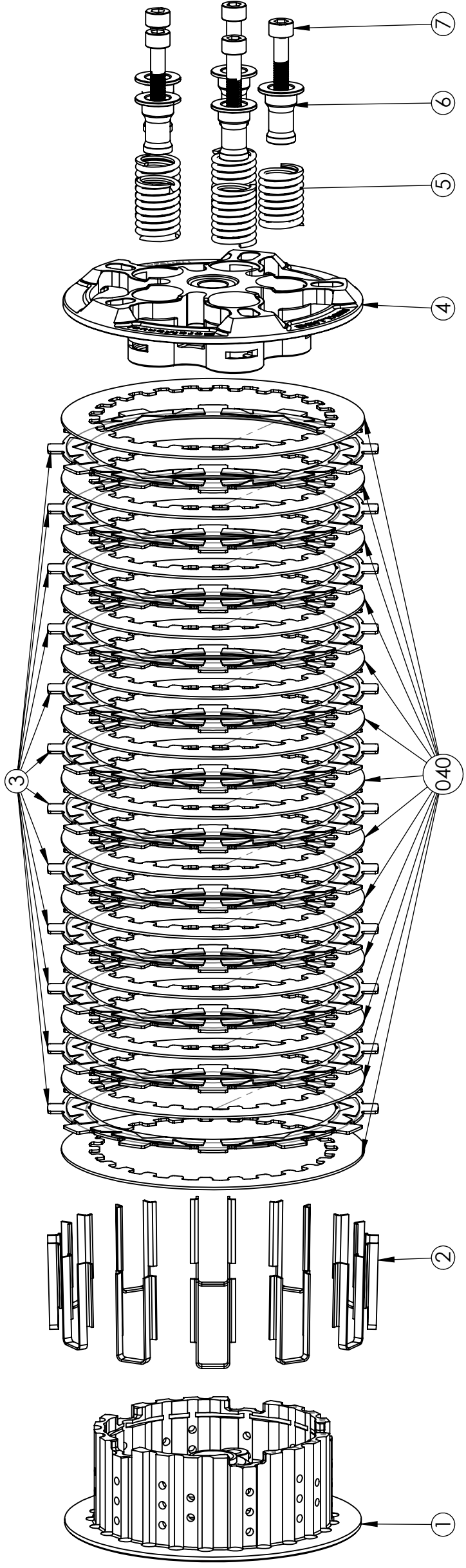

SERVICE LIMITS

COMPONENT	STANDARD	SERVICE LIMIT
TORQDRIVE FRICTION	.068-.072in 1.73-1.83mm	.065in 1.65mm

CLUTCH PACK THICKNESS

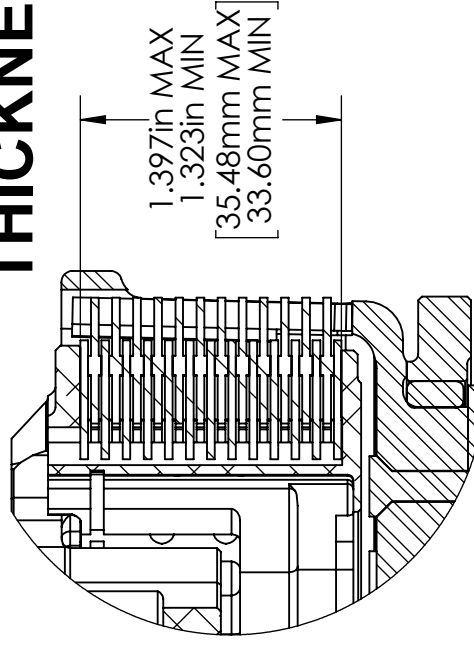

DETAIL A
SCALE 1 : 1

COMPONENTS

ITEM NO.	DESCRIPTION	QTY.
1	REKLUSE HUB	1
2	BASKET SLEEVE	12
3	TORQDRIVE FRICTION	12
4	REKLUSE PRESSURE PLATE	1
5	PRESSURE PLATE SPRING	5
6	PRESSURE PLATE SCREW SLEEVE	5
7	PRESSURE PLATE SCREW	5
040	DRIVE PLATE 0.040" (1mm)	13

INSTALLATION GUIDE

1. Soak the friction disks in clean engine oil for 10-15 minutes. Make sure the friction disks are coated on both sides. *Pouring oil into the plastic bag suffices.*

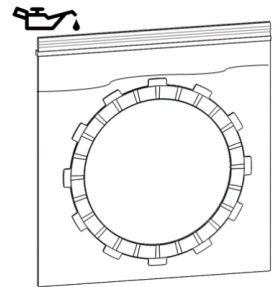

2. Remove the old clutch pack.
3. Remove the old basket sleeves and inspect the clutch basket for damper and/or spring rotational play.
 - Dampers/springs should not be loose. Inspect the clutch basket for notching. Do not install sleeves or use product with a notched basket. Notched basket tang faces can cause the sleeves to break. Do not use baskets that have been filed, machined, or modified on the tangs. Replace basket if necessary.

⚠ WARNING

Failure to inspect the basket and replace if necessary could result in death, serious injury, and/or property damage.

4. Install the new basket sleeves into the basket slots. Make sure the sleeve tabs sit against the inside of the basket, then push the sleeves down until they contact the bottom of the tang slot.

Install all the
basket sleeves

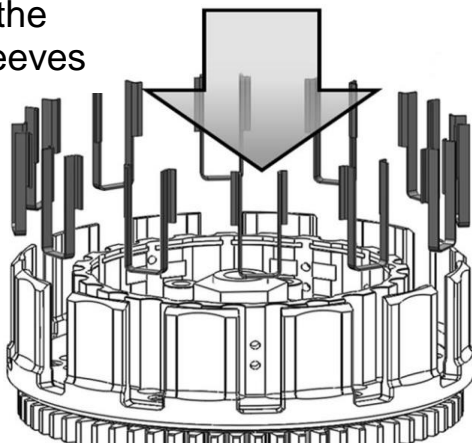

SLEEVE TOP MAY BE
ABOVE OR BELOW
BASKET TANG

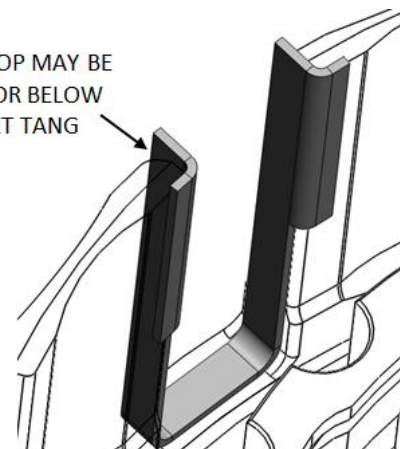

⚠ WARNING

Rekluse basket sleeves are designed to be installed into an OE or Rekluse clutch basket **ONLY**. The use of non-Rekluse aftermarket clutch baskets may cause clutch damage or failure.

5. Install the clutch pack by **starting with a steel drive plate**.
6. Add a friction disk, then continue to alternate steel drive plates with friction disks for the entire clutch pack. *Refer to the **Setup Sheet** for clutch pack disk order and thickness specifications*
7. After installation, readjust the lever free play.
8. Start the bike and warm it up for a few minutes before riding.
9. Break-in will occur over the first 1-2 hours of riding.