

REKLUSE



REKLUSE MOTOR SPORTS

The Rekluse Core EXP Clutch - Add On Kit

INSTALLATION GUIDE

191-7500A

Manual Revision: 111909

©2009 Rekluse Motor Sports
Rekluse Motor Sports, Inc.
110 E. 43rd Street
Boise, Idaho 83714
208-426-0659
support@rekluse.com

OVERVIEW

To complete the installation, you will be performing the following steps:

- Removal of your Rekluse manual pressure plate
- Re-configure clutch pack with **7** friction plates and 8 steel plates (you will remove 1 friction from your Core clutch pack setup)
- Installation of the Rekluse EXP friction disk
- Installation of the Rekluse EXP pressure plate and springs
- Setting the installed gap for break-in
- Performing clutch break-in
- Re-setting the installed gap after break-in
- Verifying proper free play gain

INSTALLATION TIPS

- Be sure to use proper eye protection
- Laying the bike on its side makes it easier to work on the clutch and eliminates the need to drain the oil
 - Be sure to turn off the gas, work in a ventilated area and be prepared to catch any gas that may drain from vent tubes
- Read and understand the maintenance guide

TOOLS NEEDED

- 5mm hex key (for Rekluse springs)
- 4mm (or 5/32") hex key (for set screws)
- 8mm, 10mm socket

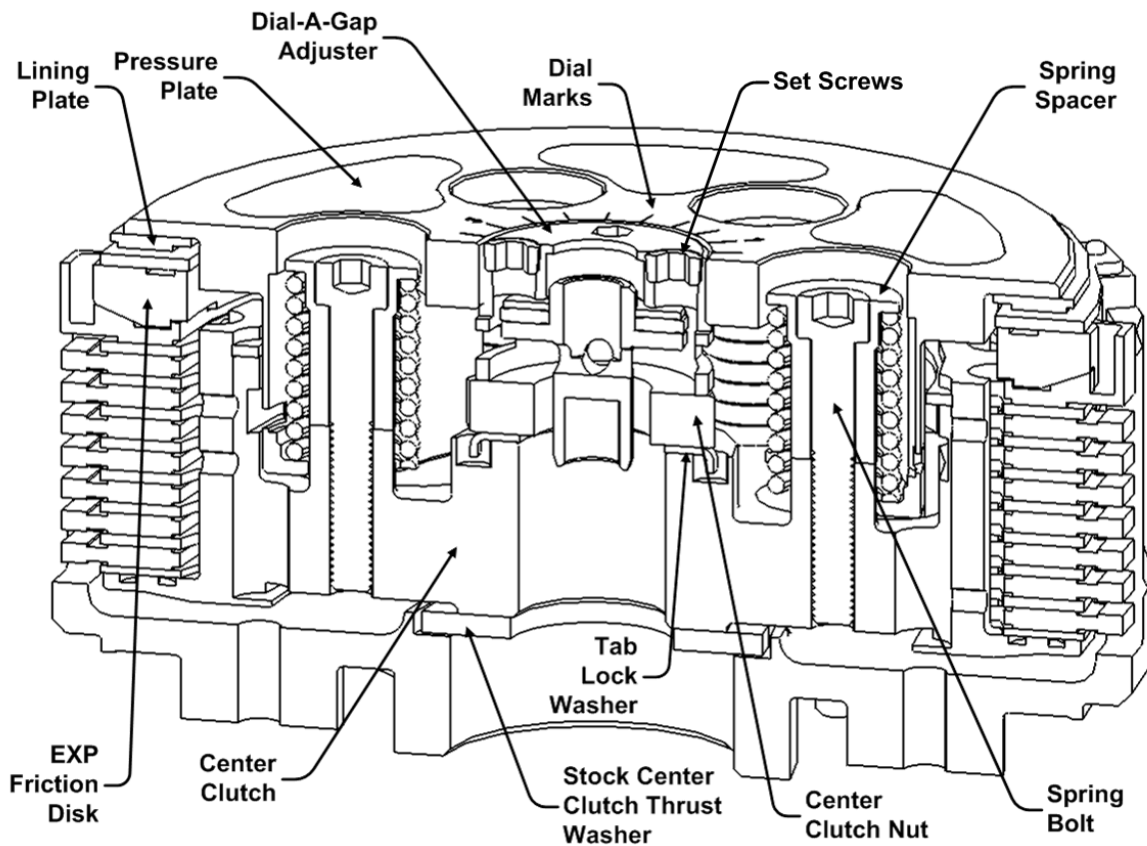

1. Soak the friction pads of the EXP assembly and the lining plate in oil for at least 5 minutes. Putting oil in the bag the EXP is packaged in will make this easy.
2. *Cable actuated bikes only:* Adjust 5-8 turns of slack into the clutch cable at the clutch lever perch.
3. Place the bike in 4th or 5th gear.
4. Lay the motorcycle on its left side and remove the clutch cover.
5. Remove the clutch springs, and Rekluse manual pressure plate.
6. Remove the top friction disk. **With Core EXP you use 7 stock frictions and 8 Rekluse drive plates starting and ending with a Rekluse drive plate.** See diagram below.

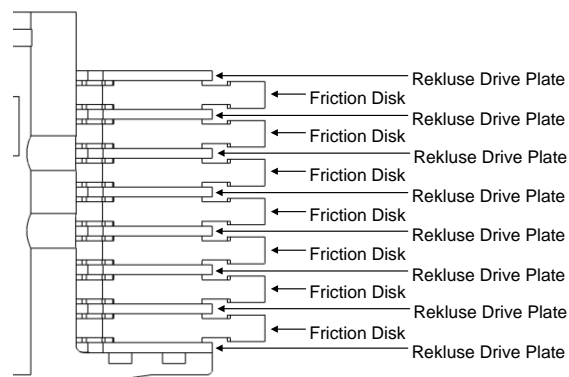

7. Install the EXP friction disk with the friction pads down (see below) against the top Rekluse drive plate. The top of the EXP friction disk, which has no friction pads, should be facing up toward you.

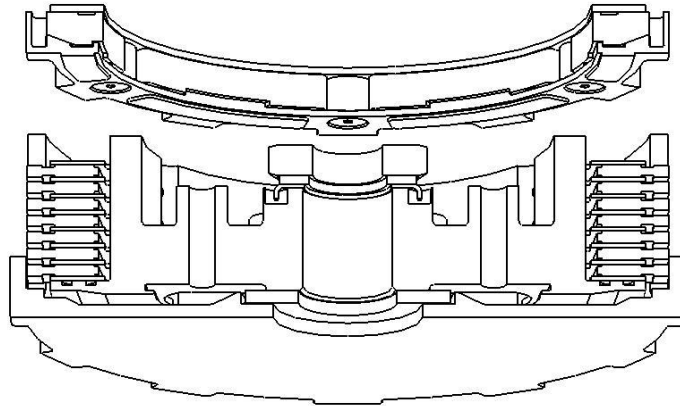

8. Verify the stock throw-out, with needle bearing and flat washer on top, is still in place on top of the throw-out rod.

NOTE: If you are missing the flat washer, it is probably stuck to the backside of the Rekluse manual pressure plate.

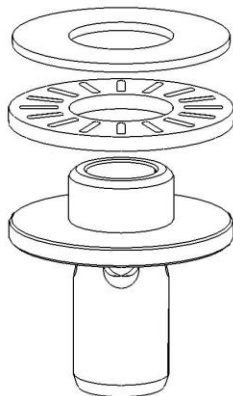

9. Place the lining plate onto the Rekluse pressure plate as shown right. Index the teeth of the lining plate into the mating slots in the Rekluse pressure plate. **The friction pads of the lining plate should face away from the pressure plate as shown at right.**

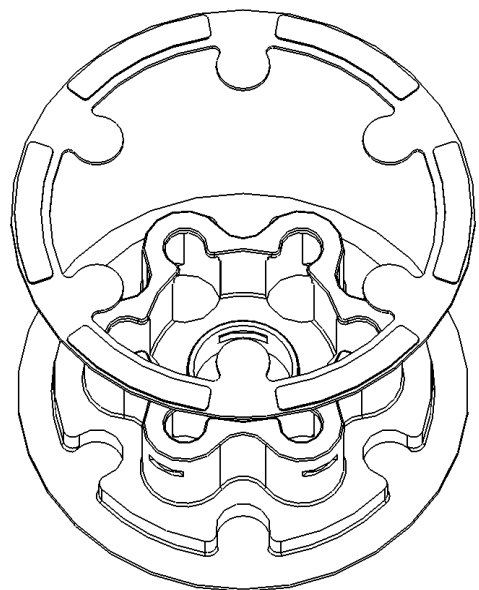

10. Install Rekluse pressure plate with lining plate onto the Rekluse center clutch. **Hold the pressure plate and lining plate together** while installing onto center clutch to ensure the lining plate teeth remained indexed into the pressure plate.

11. Install the included Rekluse springs into the pockets of the pressure plate. Place the spacers and bolts into the springs and thread each bolt in a couple of turns. Then **rotate each spring one turn counter-clockwise to ensure the spring is properly located in its spring pocket** (see picture below).

Torque each bolt to 9 ft-lbs (12 N-m).

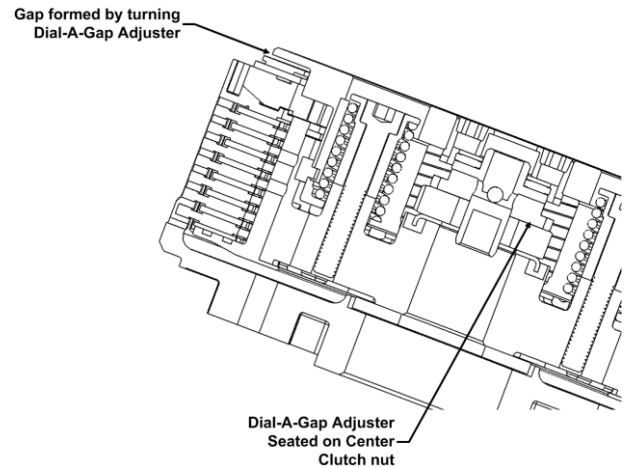
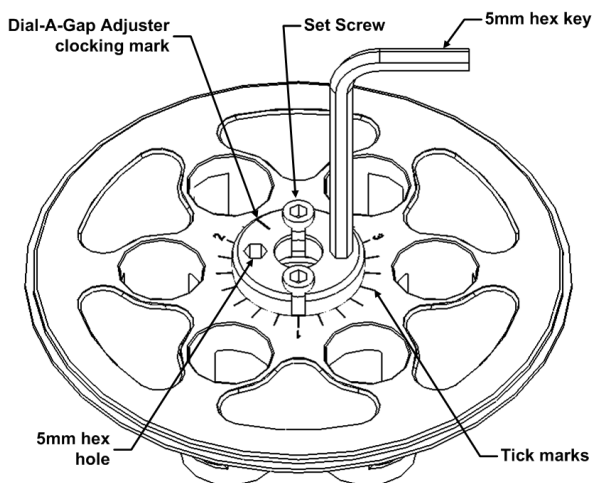
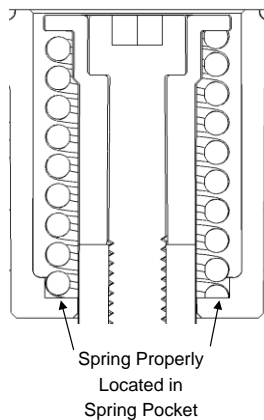

12. Insert the long end of a 5-mm hex key into either of the two 5-mm hex holes in the Dial-A-Gap adjuster. **By hand**, turn the short end of the hex key clockwise to thread the Dial-A-Gap adjuster inward. **Using moderate pressure**, turn the adjuster in until it comes to a stop against the center clutch nut. Make note of where the mark on the adjuster lines up with the tick marks on the pressure plate. This is your **starting point**.

13. *Cable actuated models only:* Check to **make sure there is lever free play**. If the clutch lever is tight, then adjust a few more turns of slack into the cable and repeat step 15.

14. Insert the short end of the 5-mm hex key into either of the two 5-mm hex holes in the Dial-A-Gap adjuster and turn the Dial-A-Gap adjuster in, clockwise, 1 full turn past the **starting point** you found in step 15. Use the tick marks to keep track of where you started.

NOTE: As the pressure plate gets raised by the adjuster, the clutch may slip and start to spin before you reach 1-full turn. With the bike in gear you can hold the rear tire to turn against.

15. Once the gap is set, tighten the 2 set screws in the Dial-A-Gap adjuster to lock it into place. Tighten the screws evenly in 2-3 steps. The set screws should be tightened to 50-60 in-lbs (5.6-6.8 N-m); moderately tight with a 4mm hex key. Do not over-tighten the set screws or you may damage the threads in the Dial-A-Gap adjuster. It is not necessary to put thread locking compound onto the set screws.

16. Install the included Rekluse clutch cover re-using your OEM clutch cover gasket.

See appendix A at the end of this manual for specific instructions for installing the Rekluse clutch cover.

NOTE: You must use the Rekluse clutch cover or you will damage the Core EXP Clutch

17. Set Clutch Lever Free Play and Check for Lever Free Play Gain

Adjust the clutch lever free play at the clutch perch according to your service manual or personal preference. You must have at least a slight amount of clutch lever free play just like the stock clutch.

Place the bike in neutral and start the engine and let it warm up for 2-3 minutes.

With the bike at idle, pull on the clutch lever lightly with a single finger so the lever free play is taken up but the clutch is not disengaged. While continuing to apply light pressure, rev the engine to at least 5000 RPMs from idle. **The clutch lever should move in under your finger pressure slightly as you**

rev the engine. This is known as free play gain.

Measured at the end of the clutch lever, the lever should come in a minimum of 1/8" (3-mm) as the engine is revved.

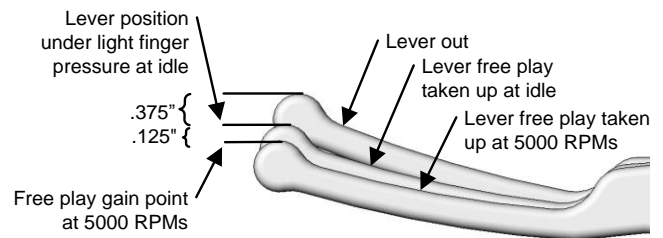

See the User's Guide for more information about Free Play Gain.

If there is no lever free play gain, you will need to reset the installed gap as described in steps 12 through 15.

18. Clutch Break-in

With the engine running, pull in the clutch lever and click the bike into gear. Slowly release the clutch lever. The bike should stay in place, perhaps with some forward creep.

Once you have the bike idling with first gear engaged, slowly apply the throttle to begin moving. To break-in the clutch components it is best to perform some roll on starts, without using the clutch lever, in 2nd and 3rd gear. In 2nd gear, accelerate moderately to approximately 5000 RPMs and come to a stop—repeat this 20 times. Next, starting in 3rd gear, accelerate moderately to approximately 5000 RPMs then come to a stop—repeat this step 10 times.

19. Resetting Installed Gap After Break-In

After break-in, the installed gap must be reset due to the initial “seat-in” of the clutch components. Before resetting the installed gap, allow the clutch to cool for 20 minutes with the cover off.

Adjust 3-4 turns of slack into the clutch cable at the clutch perch, remove the clutch cover and loosen the 2 locking set screws in the Dial-A-Gap adjuster. Using a 5-mm hex key, turn the Dial-A-Gap adjuster counter-clockwise until it is loose.

Follow steps 12 through 15 again to reset the installed gap, but reset to **1 full turn plus 3 tick marks** for the post break-in installed gap. This is the

recommended Rekluse installed gap setting.

Be sure to tighten the 2 locking set screws in the Dial-A-Gap adjuster to lock the Dial-A-Gap adjuster in place. Adjust the clutch lever free play as previously instructed. Check for free play gain as described in step 20. With an installed gap of 1 turn + 3 tick marks, the free play gain should be approximately 1/8” (3-mm) measured at the end of the lever. If you cannot feel any free play gain in the lever you must reset the installed gap.

Read the included User Guide for more information about setup and maintenance of the Core EXP clutch.

NOTE: Whenever installing new frictions or a new EXP assembly, you must go through the break-in procedure as described in steps 12 through 19. Always soak new friction disks in oil prior to installing.

NOTE: Checking free play gain is simple and takes less than a minute to perform. For maximum clutch plate life, take a moment to check for free-play gain at the start of every ride.

WARNING: DO NOT RIDE WITHOUT SUFFICIENT FREE PLAY GAIN. Your clutch may seem to operate ok but it is not getting full clamping force and may slip without you recognizing it. This can lead to premature failure of the clutch friction disks including the EXP friction disk.

EXP TUNING OPTIONS:

Included with the Rekluse Core EXP is 3 spring options to tune the engagement RPM of the EXP friction disk. The EXP friction disk comes set with the recommended "Medium" setting from Rekluse. See following charts.

450 Class Setups

Engagement Setting	Spring Configuration
Low	6 Red Springs
Medium	3 Red and 3 Blue Springs
High	6 Blue Springs

250 Class Setups

Engagement Setting	Spring Configuration
Low	3 Red and 3 Silver Springs
Medium	6 Red Springs
High	3 Red and 3 Blue Springs

NOTE: When using combinations of 3 and 3 sets of springs, you must stagger the different colored springs so the wedges are loaded evenly. For example, you will have 1 Red spring followed by 1 Blue spring until all 6 locations have one spring.

Adjusting the engine idle speed to match your engagement setting is important and greatly affects the overall feel of how the EXP friction disk engages. To prevent freewheeling and maximize engine braking, set the idle so there is a slight amount of drag while the bike is idling in gear and warmed up. This does not mean the bike is rolling forward, but with a small increase in throttle starts to move.

Optional Light Wedge Kit: This kit, consisting of 6 lighter wedges, gives the option of softening the engagement rate of the EXP friction disk. Contact Rekluse for more information.

To change springs, remove the 6 flat head screws with the included T-10 Torx tip. When re-installing screws, **use medium strength blue Loctite, and torque screws to 26 in-lbs.**

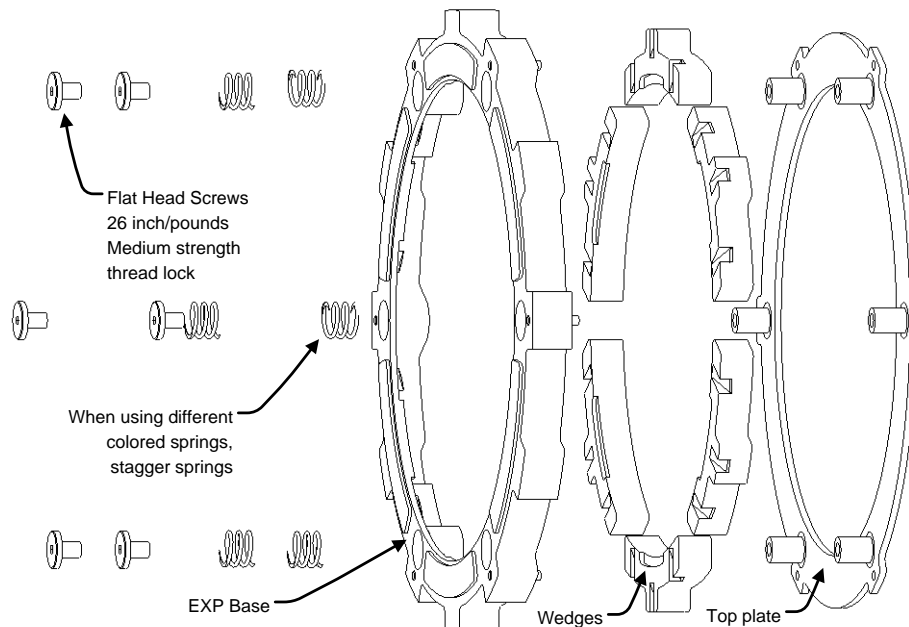

APPENDIX A

Rekluse Motor Sports

z-Start™ Clutch Cover Installation Guide

Copyright 2009 Rekluse Motor Sports

199-300

Manual Revision: 111909

Installation:

The Rekluse clutch cover provides clearance for all Rekluse clutch systems using either the OEM gasket or o-ring. If the OEM o-ring or gasket is damaged it should be replaced to guarantee proper sealing.

Some models require spacing or adjustment of the brake pedal to get clearance with the cover. See model notes below for specific instructions.

Increased Oil Capacity:

The Rekluse clutch cover is slightly deeper than the stock cover, increasing the oil capacity of some models very slightly. If your motorcycle or ATV uses a dip-stick, sight glass or oil-level check bolt, continue to use the method described in the vehicle's owner's manual to fill to the proper oil level. If your vehicle's owner's manual only specifies an oil amount, add 10cc (10ml) additional oil to the amount specified in the manual.

Model Notes:

- **KTM 400/450/505/530, Husaberg 390/450/570 FE, FX:**
To provide adequate clearance between the cover and brake pedal tip, you must remove the OEM tip and replace it with the included Rekluse tip using the provided hardware and thread lock. Your pedal position will need to be lowered about ¼-inch (6-mm) to gain necessary cover clearance. The Rekluse tip is taller to allow for this. Refer to your owner's manual for instructions about properly adjusting brake pedal height.
- **KX250F/KX450F/KLX450F:**
To provide clearance between the cover and brake pedal, install included brake pedal spacer between frame and pedal in place of the thinner OEM spacer.
- **04-08 KX250F and 04-06 RMZ250:**
You must use the included gasket with the Rekluse clutch cover to provide adequate clearance for the Core EXP clutch—failure to do so will result in clutch damage. You must also install the included brake pedal spacer.